

PhoXi 3D Scanner XL

Quick Start Guide



Scope of Delivery

- PhoXi 3D Scanner XL
- Desktop PoE injector (input: 90 ~ 264 VAC, output: 33.6 W, 56 V PoE, IEEE802.3at)
- M12-X (m) RJ45 (m) ethernet cable

Operation of the Scanner

The scanner is operated by the PhoXi Control application. PhoXi Control allows the user to control the scanner either manually through a graphical user interface or programmatically through the provided API.

All PhoXi Control resources can be found on the following link:

www.photoneo.com/3d-scanning-software/

Read the complete PhoXi 3D Scanner Manual for more details:

www.photoneo.com/kb/scanner

Scanning Parameters - Model XL

Parameter	Value
Resolution	Up to 3.2 Million 3D points
Scanning range	1680 - 3780 mm
Optimal scanning distance (sweet spot)	2326 mm
Scanning area (at sweet spot)	1954 x 1459 mm
Point to point distance (at sweet spot)	0.947 mm
Calibration accuracy (1 σ)	0.500 mm
Temporal noise (1 σ)	0.400 mm
Scanning time	250 - 3000 ms
Dimensions	77 x 68 x 941 mm
Baseline	850 mm
Weight	1200 g
3D point throughput	16 Million points per second

These parameters are valid at 22 °C - 25 °C, at focus distance for white objects with 80 % albedo.

Scanning Volume - Model XL

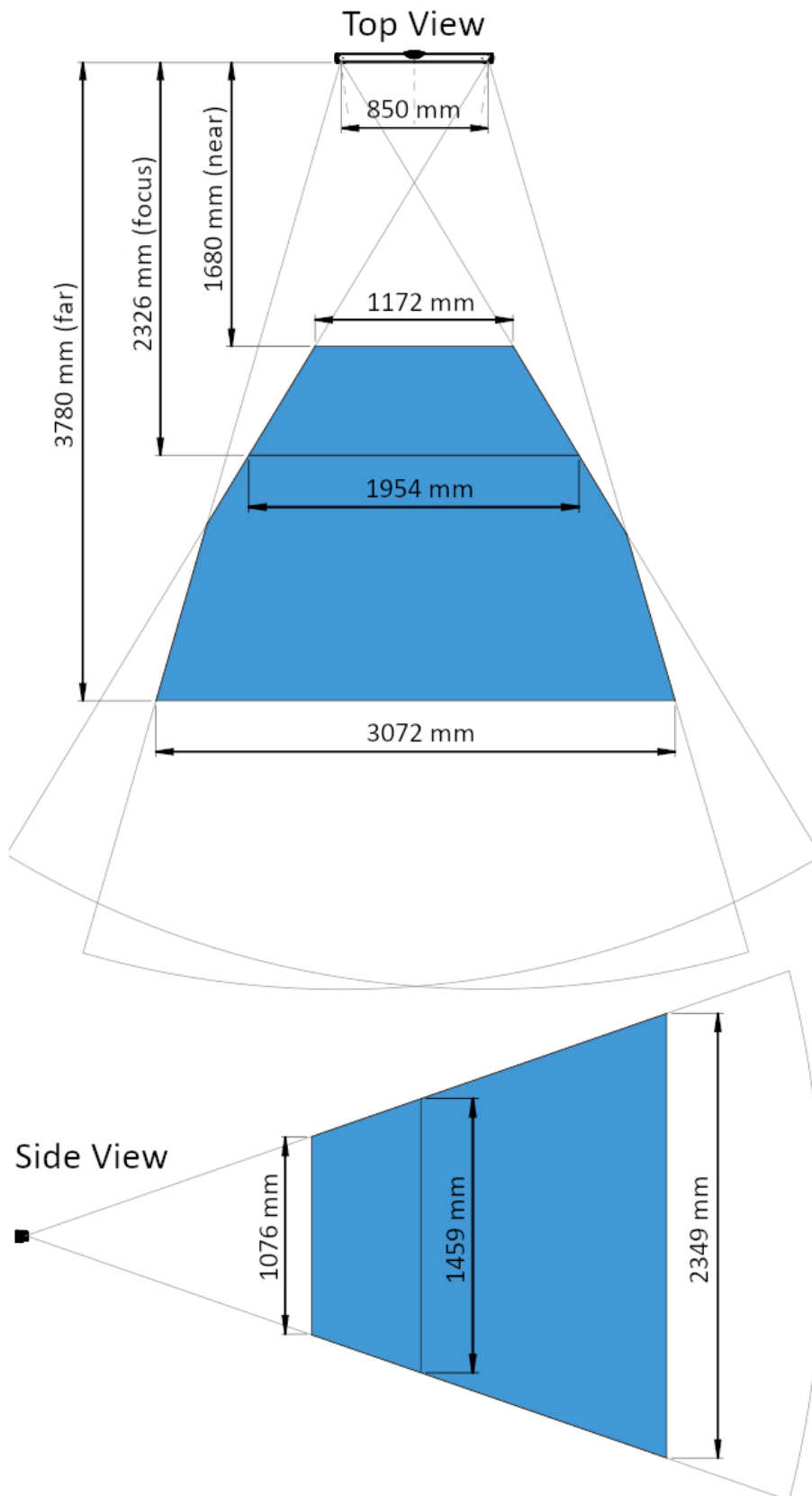

Mounting the Scanner

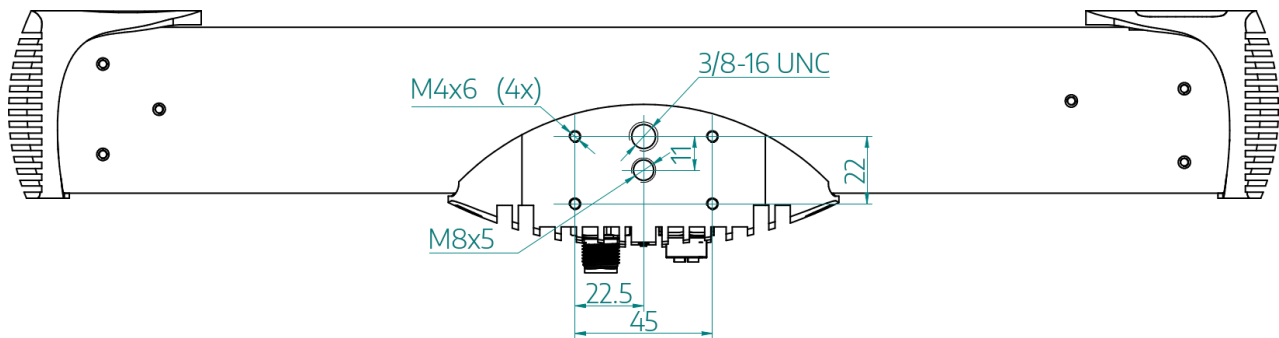

Mounting options:

- Use 4x M4 screws with a metal mounting plate of suitable size - preferred mounting method for heat dissipation.
- Use a M8 screw.
- Use a 3/8 - 16 UNC screw with a tripod.

⚠ WARNING

Hot surface warning

The surface of the processing unit becomes hot to touch when the device is in use. Mount the device on a metal mounting plate that will act as a thermal bridge to dissipate the heat or use the carbon body to manipulate the device.

Installation site restrictions:

- Ensure that mounting construction is rigid enough to avoid vibrations during scanning.
- Allow clearance of 25 mm for natural convection cooling.
- Operating temperature of the scanner is 0 °C to 45 °C.
 - Operating temperature for optimal scanning performance is 22 °C to 25 °C.
- Separate the scanner from high-voltage devices and devices generating high electrical noise.

The complete environment conditions for installation can be found in the full user manual at

www.photoneo.com/kb/scanner

Connecting to the Scanner

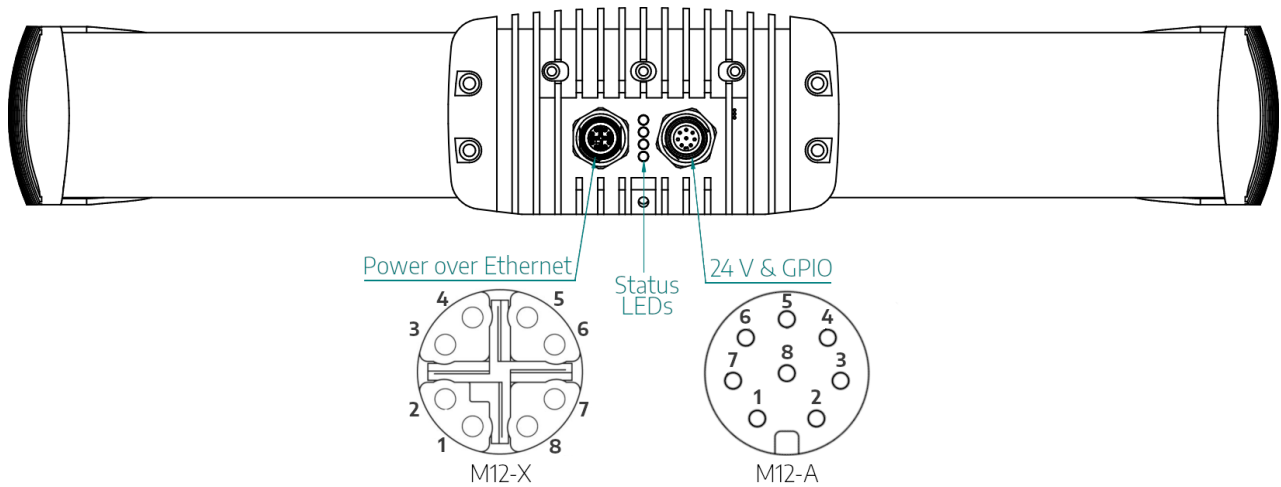

Power over ethernet:

- Recommended powering option
- 1 Gbps ethernet cable to the PoE injector IN port
- M12-X ethernet cable to the PoE injector OUT port

24 V & GPIO:

- Desktop & DIN rail adapters supported

M12 A Coded - 24 V & GPIO Pinout

Pin	Cable Color	Pinout	Function
1	White	DC_IN	+ 24 V
2	Brown	OPTO_IN2_GND	*laser interlock ground
3	Green	GND	ground
4	Yellow	OPTO_IN1	-
5	Grey	OPTO_IN1_GND	-
6	Pink	OPTO_OUT	-
7	Blue	OPTO_OUT_GND	-
8	Red	OPTO_IN2	*laser interlock signal (5 - 24 V)

* laser interlock requires special firmware package

Status LEDs

The LEDs indicate the following states of the scanner:

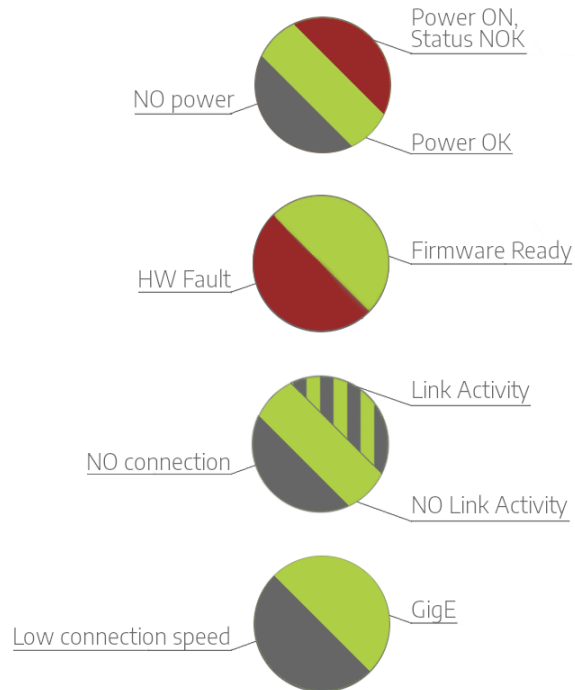

Supported Network Topologies

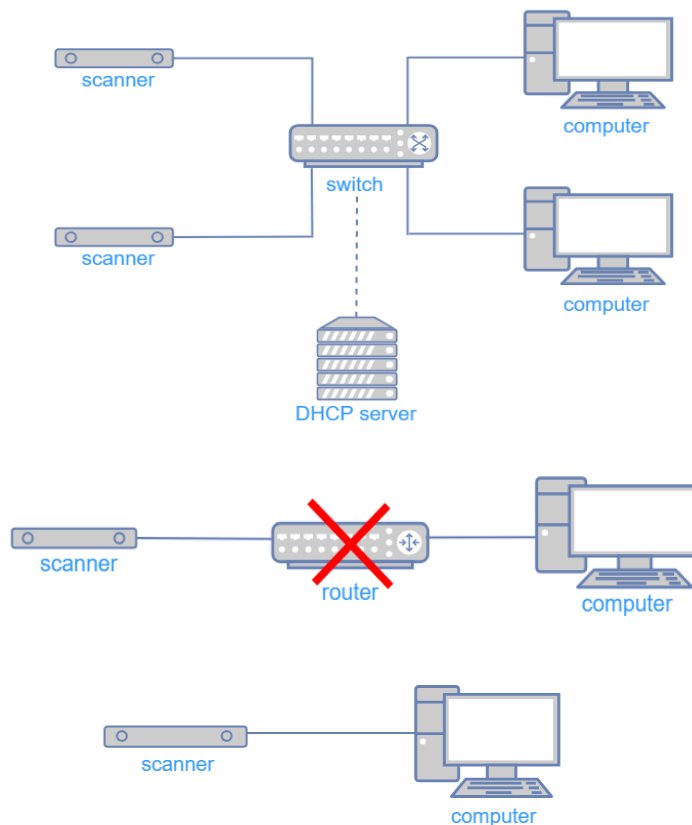

Powering Requirements

Connector	M12 X coded	M12 A coded
PoE Standard	IEEE802.3at	-
Operating voltage U_e DC	min. 55 V	24 V (20 - 30 V)
Residual ripple maximum (% of U_e)	0.5 %	2 %
Rated operating current I_e (I_{max})	0.36 A (0.6 A)	1 A (2 A)
Minimum power	33 W	60 W
Shielding	Fully Shielded RJ45	-
Transfer data rate	1 Gbit	-
Maximum recommended cable length	20 m	20 m*

* for cable length over 10 m use 36 V DC adapter (60 W)

Powering Accessories for Custom Cablings

PhoXi 3D Scanners offer several options to connect the device. See the [PhoXi 3D Scanner User Manual](#) for more information.

Photoneo offers a selection of:

- Cables in different configurations of lengths and materials,
- Adapters (desktop, DIN),
- Old PhoXi 3D Scanner cabling compatibility accessories
- Please contact your sales representative for inquiries about the available options.

Warranty

Warranty conditions are stated in General Term and Conditions on Photoneo website:

www.photoneo.com/kb/terms-conditions

Safety

PhoXi 3D Scanner Model XL is a **laser class 3R** device or a **laser class 2** device. Class 3R lasers are considered safe when handled carefully. Class 2 lasers are considered safe for normal operation. See the label on the back of the device to determine its laser class.

Laser class 3R label



Laser class 2 label



WARNING

Do not deliberately look into the laser beam. This may cause injury to the retina.

Laser protective eyewear is normally not necessary.



RoHS