

KINOVA™ *Ultra lightweight robotic arm*  
6 DOF

# Specifications



# Tech Specs

KINOVA™  
Ultra lightweight  
robotic arm

6 DOF

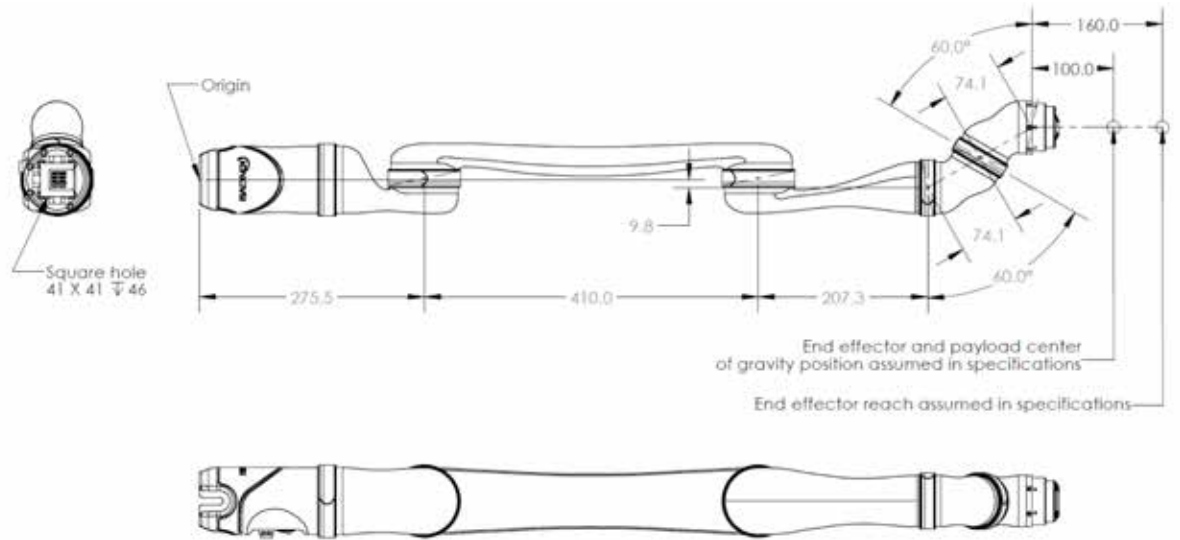

## GENERAL

		NO GRIPPER	2 FINGERS (KG-2)	3 FINGERS (KG-3)
<b>Total weight</b>		4.4 kg	5.0 kg	5.2 kg
<b>Payload capabilities</b>	Mid-range continuous	2.6 kg	1.8 kg	1.6 kg
	Full-reach peak/temporary	2.2 kg	1.5 kg	1.3 kg
<b>Materials</b>	Links	Carbon fiber		
	Actuators	Aluminum		
<b>Maximum reach</b>		90 cm		
<b>Joint range after start-up</b>	<i>(software limitation)</i>	±27.7 turns		
<b>Maximum linear arm speed</b>		20 cm/s		
<b>Power supply voltage</b>		18 to 29 VDC, 24 VDC nominal		
<b>Peak power</b>		100 W		
<b>Average power</b>	Operating mode	25 W		
	Standby mode	5 W		
<b>Communication protocol</b>		RS-485		
<b>Communication cables</b>		20 pins flat flex cable		
<b>Expansion pins</b>		2 <i>(on communication bus)</i>		
<b>Water resistance</b>		IPX2		
<b>Operating temperature</b>		-10 °C to 40 °C		

## CONTROLLER

<b>Ports</b>	Joystick	1 Mbps Canbus
	Power supply	18 to 29 VDC, 24 VDC nominal
	USB 2.0 (API)	12 Mbps
	Ethernet (API)	100 Mbps
<b>Control system frequency</b>	High level (API)	100 Hz
	Low level (API)	Up to 500 Hz
<b>CPU</b>		360 MHz
<b>SDK</b>	APIs	High and low level
	Compatibility	Windows, Linux Ubuntu & ROS
	Port	USB 2.0, Ethernet
	Programming languages	C++
<b>Control</b>		Force, cartesian & angular

## SPECIFICATIONS

<b>Actuators #1, #2 &amp; #3</b>	KA-75+
<b>Actuators #4, #5 &amp; #6</b>	KA-58