



# IRB 1520ID

## The Lean Arc Welder

# Introduction

## ABB – the pioneer in robotic arc welding



- ABB sold the world's first arc welding robot in 1975
- ABB has since delivered over 25 000 arc welding robots
- The ABB offer:
  - Easy to achieve top welding quality
  - Highest possible reliability

# Introduction

## IRB 1520ID - The lean arc welder



- The IRB 1520ID is a new arc welding robot with an incredibly lean design
- Arc welding process interface on FlexPendant
  - Available for Kemppi, Esab and Fronius, more to come
  - Single point of programming
- Designed for single wire MIG/MAG welding with air or water cooling

# Introduction

## The lean arc welder – 7 key values



1. Simple installation and commissioning → robot **up and running in hours**
2. The compact arc welding robot **requires a minimum of workshop floor area**
3. Integrated hose package and welding cabling plus outstanding motion control result in **increased welding quality**
4. **Easy access to narrow spaces** with slim upper arm design
5. **Higher production uptime and lower maintenance costs** thanks to closely integrated hose package and welding cabling along the whole manipulator
6. **Outstanding welding reliability** thanks to fast restart after weld stop, optional automatic collision detection and BullsEye torch calibration
7. **Energy efficient** thanks to ABB's unique motion control and low manipulator weight

# Key value 1

## Up and running in hours

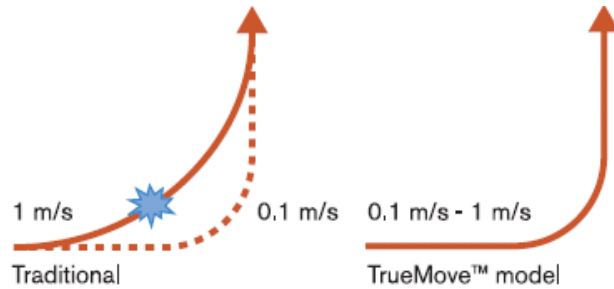

- Easy-to-use FlexPendant
  - Touch screen and familiar PC interface
  - Intuitive joystick for easy jogging and adjustments
  - Easy program backing-up
- Easy programming
  - Access to all functionality of the power source from the FlexPendant
  - Powerful programming with RobotWare Arc and RobotStudio Arc Welding PowerPac
  - Predictable welding results with VirtualArc
  - “What you program is what you get” with TrueMove
  - Improved motion predictability without swinging cables
- Fast definition of TCP by using BullsEye

# Key value 2

## Requires a minimum of workshop floor space



- Compact swing base enables a robot position near the workpiece, reducing floor space **and** cycle times
- Cabling is well integrated along the upper and lower arm → allowing higher robot density
- Inverted mounting possible releasing floor space



# Key value 3

## Increased welding quality



With TrueMove

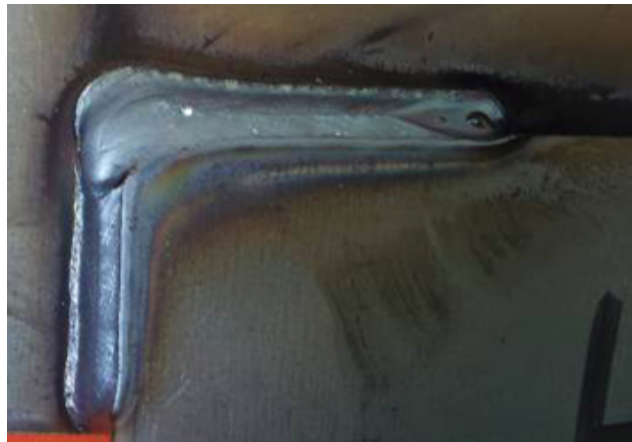

Without TrueMove

- Welding cabling are well integrated along the upper and lower arms → less swinging affecting the weld
- Superior motion control with TrueMove
- Accurate definition of TCP by using BullsEye

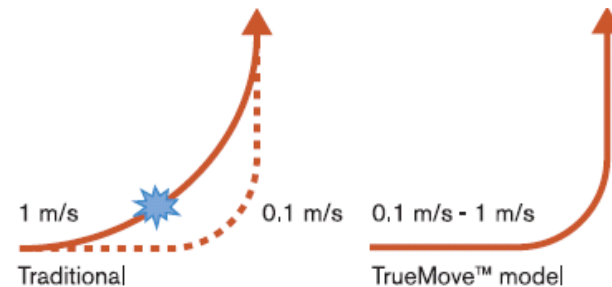



# Key value 4

## Easy access to narrow spaces



- Compact design of upper arm and well integrated hose package enable welding in tight spaces

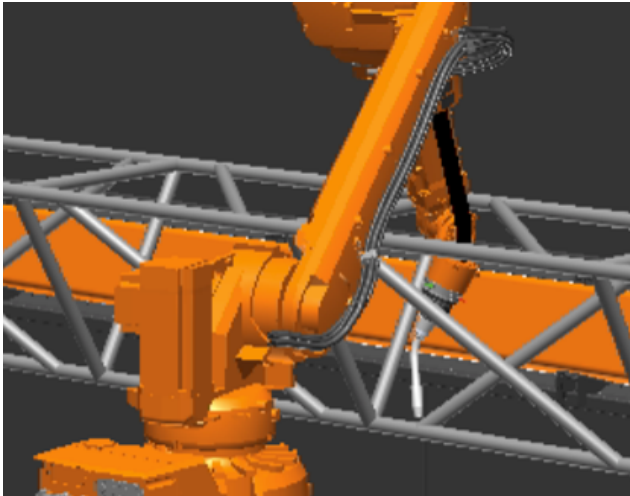



# Key value 5.1

## Higher production uptime, lower maintenance costs



### Upper arm

- The hose packages include a one year warranty when supplied by Binzel
- The hose package is well integrated with the upper arm and is well protected from wear and weld spatter
- The wrist design optimizes the bending radius for a long life expectancy



# Key value 5.2

## Higher production uptime, lower maintenance costs



### Lower arm and base

- Fully integrated welding cabling\* along the lower arm and base for a more compact, protected and reliable solution

\*) Included with the RPC process equipment package

# Key value 6

## Outstanding welding reliability

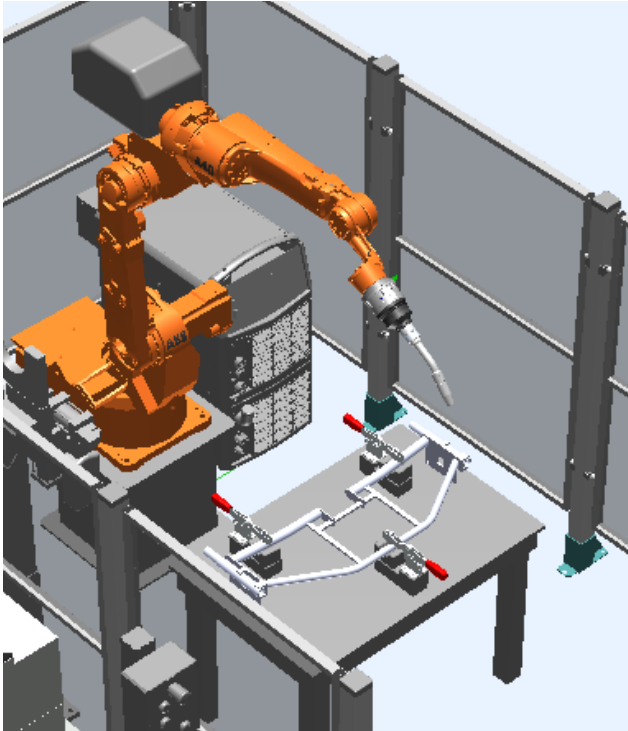

- The hose package will never interfere with the fixture, the workpiece or other objects
- Fast restart after weld stop thanks to powerful error recovery (RobotWare Arc)
- Built-in automatic collision detection (software option)
- Automatic BullsEye torch calibration (option)

# Key value 7

## Energy efficient



- Approx. 0.5 - 1 kW less power consumption compared to competitor robots
  - ABB:s 2nd generation unique motion control with QuickMove and TrueMove
  - Low manipulator weight

# Load diagram with additional armloads (10 kg) Up to 4 kg

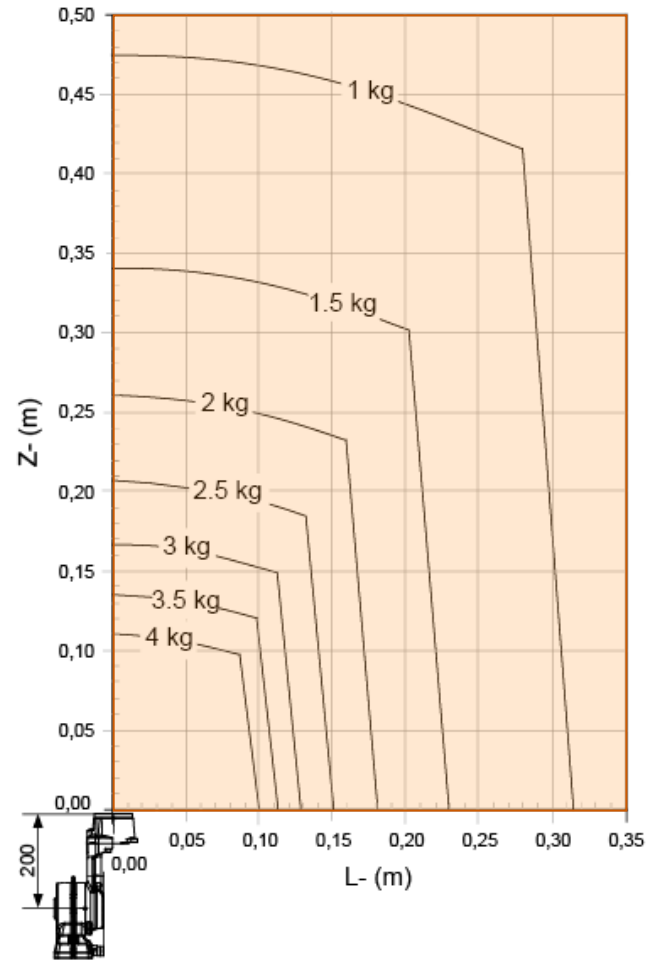
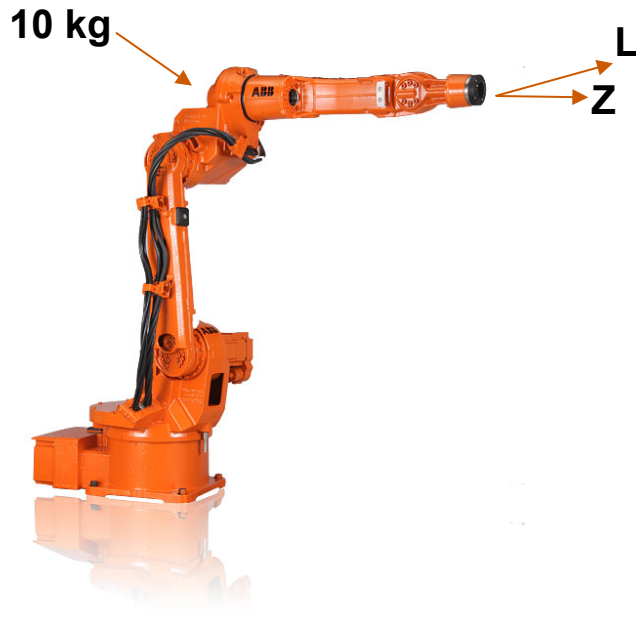

# Working range at center of 5th axis

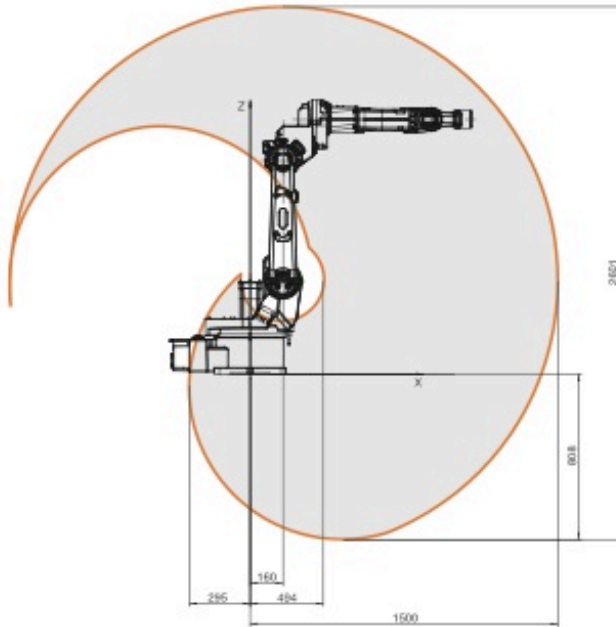

- Reach forward: 1500 mm
- Reach below the base: 808 mm
- Reach above the base: 1793 mm
- Horizontal stroke: 2680 mm

# Easy to integrate

## Mechanical mounting interfaces

