

IRB 1520ID

The Lean Arc Welder



This high precision robotic arc welder, with integrated process dressing, combines 24/7 production output with 50% lower cost of maintenance to deliver the lowest cost per weld in its class.

Dedicated arc welding robot

With IRB 1520ID (Integrated Dressing), the hose package is totally integrated into the upper arm and through the base of the robot. This means, all media necessary for arc welding, including power, welding wire, shielding gas and pressurized air is routed for maximized performance and energy efficiency. The IRB 1520ID delivers stable welding, excellent path accuracy, short cycle times and extended life expectancy of the hose package. Thanks to the integrated dressing, welding around cylindrical objects can be carried out without any stops and narrow spaces are more easily accessed.

Flexible installation

With a payload capacity of 4 kilograms and a reach of 1.5 meters, the highly compact IRB 1520ID can be mounted in both floor and inverted position. This positioning flexibility offers short cycle times and a wide range of production possibilities.

Superior accuracy and speed

ABB robots are renowned for their superior motion control. With the second generation TrueMove™ technology, IRB 1520ID has an outstanding path accuracy. With the second generation QuickMove™ technology, the robot is able to utilize maximum acceleration between welds to increase output with minimum energy consumption.

Easy to use, Easy to program

Both robot and arc welding process are easily programmed and maintained with the ABB FlexPendant. It has a intuitive graphical interface which lets the operators control the robot and selected process equipment in their own language. It is equipped with a touchscreen and the unique ABB joy-stick for quick and easy positioning of the robot. If you appreciate the benefits of simulating and programming offline, ABB offers the most popular, reliable and cost-efficient software packages with RobotStudio™ and RobotStudio Arc Welding PowerPac. The robot will produce predictable cycle times and welding quality after only a few hours.

Global service and support

For worry-free operation, ABB also offers Remote-Service, which gives remote access to equipment for monitoring and support. Moreover, ABB customers can take advantage of the company's service organization; with more than 35 years of experience in the arc welding sector, ABB provides service support in over 100 locations in 53 countries.

Main applications

- Arc Welding

Specification

Robot version	Reach (m)	Payload (kg)	Armload (kg)
IRB 1520ID	1.5	4	10
Number of axes	6		
Protection	IP40		
Mounting	Floor, inverted		
Controller	IRC5 Single Cabinet		

Performance (according to ISO 9283)

IRB 1520ID	
Position repeatability	0.05 mm
Path repeatability	0.35 mm

Technical information

Electrical Connections

Supply voltage	380 V
Power consumption	ISO cube 0.6 kW

Physical

Robot base	300 x 300 mm
Robot weight	170 kg

Environment

Ambient temperature for mechanical unit	
During operation	+5° C (41° F) to + 45° C (113° F)
During transportation and storage	-25° C (-13° F) to +55° C (131° F)
During short periods (max. 24 h)	up to +70° C (158° F)

Relative humidity	Max. 95%
-------------------	----------

Safety	Double circuits with supervisions, emergency stops and safety functions. 3-position enable device
--------	---------------------------------------------------------------------------------------------------

Emission	EMC/EMI shielded
----------	------------------

Data and dimensions may be changed without notice.

Movement

Axis movement	Working range	Axis max. speed
Axis 1 rotation	+170° to -170°	130°/s
Axis 2 arm	+150° to -90°	140°/s
Axis 3 arm	+80° to -100°	140°/s
Axis 4 rotation	+155° to -155°	320°/s
Axis 5 bend	+135° to -135°	380°/s
Axis 6 * turn	+200° to -200°	460°/s

Working range

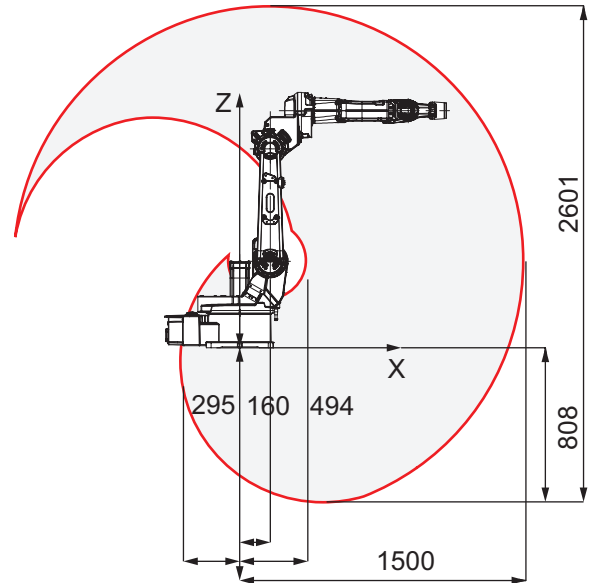

We reserve the right to make technical changes or modify the contents of this document without prior notice. With regard to purchase orders, the agreed particulars shall prevail. ABB does not accept any responsibility whatsoever for potential errors or possible lack of information in this document.

We reserve all rights in this document and in the subject matter and illustrations contained therein. Any reproduction, disclosure to third parties or utilization of its contents – in whole or in parts – is forbidden without prior written consent of ABB. Copyright© 2019 ABB All rights reserved