

ROBOTICS

Product manual

IRB 6700



Trace back information:
Workspace 22A version a16
Checked in 2022-03-11
Skribenta version 5.4.005

Product manual

IRB 6700 - 235/2.65

IRB 6700 - 205/2.80

IRB 6700 - 175/3.05

IRB 6700 - 150/3.20

IRB 6700 - 200/2.60

IRB 6700 - 155/2.85

IRB 6700 - 300/2.70

IRB 6700 - 245/3.00

IRC5, OmniCore

Document ID: 3HAC044266-001

Revision: X

The information in this manual is subject to change without notice and should not be construed as a commitment by ABB. ABB assumes no responsibility for any errors that may appear in this manual.

Except as may be expressly stated anywhere in this manual, nothing herein shall be construed as any kind of guarantee or warranty by ABB for losses, damage to persons or property, fitness for a specific purpose or the like.

In no event shall ABB be liable for incidental or consequential damages arising from use of this manual and products described herein.

This manual and parts thereof must not be reproduced or copied without ABB's written permission.

Keep for future reference.

Additional copies of this manual may be obtained from ABB.

Original instructions.

© Copyright 2013 - 2022 ABB. All rights reserved.
Specifications subject to change without notice.

Table of contents

Overview of this manual	9
Product documentation	15
How to read the product manual	17
1 Safety	19
1.1 Safety information	19
1.1.1 Limitation of liability	19
1.1.2 Requirements on personnel	20
1.2 Safety signals and symbols	21
1.2.1 Safety signals in the manual	21
1.2.2 Safety symbols on manipulator labels	23
1.3 Robot stopping functions	29
1.4 Safety during installation and commissioning	30
1.5 Safety during operation	33
1.6 Safety during maintenance and repair	34
1.6.1 Safety during maintenance and repair	34
1.6.2 Emergency release of the robot axes	37
1.6.3 Brake testing	38
1.7 Safety during troubleshooting	39
1.8 Safety during decommissioning	40
2 Installation and commissioning	41
2.1 Introduction to installation and commissioning	41
2.2 Unpacking	42
2.2.1 Pre-installation procedure	42
2.2.2 Working range	46
2.2.3 Risk of tipping/stability	52
2.2.4 Main dimensions	53
2.2.5 The unit is sensitive to ESD	55
2.3 On-site transportation	56
2.3.1 Robot transportation precautions	56
2.3.2 Securing the robot with a transport support	60
2.4 On-site installation	62
2.4.1 Brief installation procedure	62
2.4.2 Lifting the base plate	63
2.4.3 Securing the base plate	64
2.4.4 Lifting the robot	66
2.4.4.1 Lifting the robot with fork lift	66
2.4.4.2 Lifting robot with lifting accessory	67
2.4.4.3 Lifting the robot with roundslings	69
2.4.5 Orienting and securing the robot	73
2.4.6 Manually releasing the brakes	78
2.4.7 Loads fitted to the robot, stopping time and braking distances	80
2.4.8 Fitting equipment to the robot	81
2.4.9 Extended working range, axis 1 (option)	86
2.5 Restricting the working range	87
2.5.1 Axes with restricted working range	87
2.5.2 Mechanically restricting the working range of axis 1	88
2.6 Electrical connections	90
2.6.1 Robot cabling and connection points	90
2.7 Installation of options	94
2.7.1 Signal lamp (option)	94
2.7.2 Installing the motor cooling fan (option)	95
2.8 Start of robot in cold environments	101

3	Maintenance	103
3.1	Introduction	103
3.2	Maintenance schedule and expected component life	104
3.2.1	Specification of maintenance intervals	104
3.2.2	Maintenance schedule	105
3.2.3	Expected component life	107
3.3	Inspection activities	108
3.3.1	Inspecting the motor seal	108
3.3.2	Inspecting the oil level in axis-1 gearbox	110
3.3.3	Inspecting the oil level in axis-2 gearbox	115
3.3.4	Inspecting the oil level in axis-3 gearbox	117
3.3.5	Inspecting the oil level in axis-4 gearbox	120
3.3.6	Inspecting the oil level in axis-5 gearbox	122
3.3.7	Inspecting the oil level in axis-6 gearbox	124
3.3.8	Inspecting the balancing device	127
3.3.9	Inspecting the cable harness	131
3.3.10	Inspecting the information labels	133
3.3.11	Inspecting the axis-1 mechanical stop pin	137
3.3.12	Inspecting the additional mechanical stops	139
3.3.13	Inspecting the dampers	141
3.3.14	Inspecting the signal lamp (option)	143
3.4	Replacement/changing activities	145
3.4.1	Type of lubrication in gearboxes	145
3.4.2	Changing oil, axis-1 gearbox	147
3.4.3	Changing oil, axis-2 gearbox	154
3.4.4	Changing oil, axis-3 gearbox	159
3.4.5	Changing oil, axis-4 gearbox	165
3.4.6	Changing oil, axis-5 gearbox	169
3.4.7	Changing oil, axis-6 gearbox	173
3.4.8	Replacing the SMB battery	177
3.5	Lubrication activities	180
3.5.1	Lubricating the spherical roller bearing, balancing device	180
3.6	Cleaning activities	182
3.6.1	Cleaning the IRB 6700	182
4	Repair	185
4.1	Introduction	185
4.2	General procedures	186
4.2.1	Performing a leak-down test	186
4.2.2	Mounting instructions for bearings	187
4.2.3	Mounting instructions for sealings	189
4.2.4	Cut the paint or surface on the robot before replacing parts	192
4.2.5	The brake release buttons may be jammed after service work	193
4.3	Lifting associated procedures	194
4.3.1	Attaching lifting accessories to complete arm system (IRB 6700-235/2.65, -205/2.80, -175/3.05, -150/3.20, -200/2.60, -155/2.85)	194
4.3.2	Attaching lifting accessories to complete arm system (IRB 6700 -300/2.70, -245/3.00)	199
4.3.3	Attaching lifting accessories to an un-separated lower and upper arm (IRB 6700-235/2.65, -205/2.80, -175/3.05, -150/3.20, -200/2.60, -155/2.85)	205
4.3.4	Attaching lifting accessories to an un-separated lower and upper arm (IRB 6700 -300/2.70, -245/3.00)	211
4.3.5	Attaching lifting accessories to the upper arm	216
4.4	Complete robot	219
4.4.1	Removing the cable harness	219
4.4.2	Refitting the cable harness	243
4.4.3	Replacing the SMB	273
4.4.4	Replacing the brake release unit	279

4.5	Upper and lower arms	284
4.5.1	Replacing the upper arm	284
4.5.2	Replacing the wrist	327
4.5.3	Replacing the turning disc	352
4.5.4	Replacing the process turning disc	358
4.5.5	Replacing the lower arm	364
4.6	Frame and base	430
4.6.1	Replacing spherical roller bearing, link ear	430
4.6.2	Replacing the balancing device	448
4.6.3	Replacing the rear bearings on the balancing device	467
4.6.4	Replacing the stop pin	479
4.7	Motors	483
4.7.1	Replacing the axis-1 motor	483
4.7.2	Replacing the axis-2 motor	497
4.7.3	Replacing the axis-3 motor	510
4.7.4	Replacing the axis-4 motor	522
4.7.5	Replacing the axis-5 motor	533
4.7.6	Replacing the axis-6 motor	550
4.8	Gearboxes	564
4.8.1	Replacing the axis-1 gearbox (IRB 6700 - 235/2.65, IRB 6700 - 205/2.80, IRB 6700 - 175/3.05, IRB 6700 - 150/3.20, IRB 6700 - 200/2.60, IRB 6700 - 155/2.85)	564
4.8.2	Replacing the axis-1 gearbox (IRB 6700 - 300/2.70, IRB 6700 - 245/3.00)	603
4.8.3	Replacing the axis-2 gearbox (IRB 6700 - 235/2.65, IRB 6700 - 205/2.80, IRB 6700 - 175/3.05, IRB 6700 - 150/3.20, IRB 6700 - 200/2.60, IRB 6700 - 155/2.85)	642
4.8.4	Replacing the axis-2 gearbox (IRB 6700 - 300/2.70, IRB 6700 - 245/3.00)	680
4.8.5	Replacing the axis-3 gearbox	718
4.8.6	Replacing the axis-6 gearbox	755
5	Calibration	767
5.1	Introduction to calibration	767
5.1.1	Introduction and calibration terminology	767
5.1.2	Calibration methods	768
5.1.3	When to calibrate	771
5.2	Synchronization marks and axis movement directions	772
5.2.1	Synchronization marks and synchronization position for axes	772
5.2.2	Calibration movement directions for all axes	774
5.3	Updating revolution counters	775
5.3.1	Updating revolution counters on IRC5 robots	775
5.3.2	Updating revolution counters on OmniCore robots	779
5.4	Calibrating with Axis Calibration method	781
5.4.1	Description of Axis Calibration	781
5.4.2	Calibration tools for Axis Calibration	784
5.4.3	Installation locations for the calibration tools	786
5.4.4	Axis Calibration - Running the calibration procedure	787
5.4.5	Reference calibration	791
5.5	Calibrating with Calibration Pendulum method	793
5.6	Calibrating with Wrist Optimization method	794
5.7	Verifying the calibration	796
5.8	Checking the synchronization position	797
6	Decommissioning	799
6.1	Environmental information	799
6.2	Scrapping of robot	801
6.3	Decommissioning of balancing device	802
7	Robot description	805
7.1	Type A vs type B motors	805

Table of contents

8	Reference information	807
8.1	Introduction	807
8.2	Applicable standards	808
8.3	Unit conversion	809
8.4	Screw joints	810
8.5	Weight specifications	813
8.6	Standard toolkit	814
8.7	Special tools	815
8.8	Lifting accessories and lifting instructions	820
9	Spare parts	821
9.1	Spare part lists and illustrations	821
10	Circuit diagrams	823
10.1	Circuit diagrams	823
Index		825

Overview of this manual

About this manual

This manual contains instructions for:

- mechanical and electrical installation of the IRB 6700
- maintenance of the IRB 6700
- mechanical and electrical repair of the IRB 6700

The robot described in this manual has the following protection types:

- *Standard*
- *Foundry Plus*

This manual describes the manipulator using either the IRC5 or the OmniCore controller.

Product manual scope

The manual covers all variants and designs of the IRB 6700. Some variants and designs may have been removed from the business offer and are no longer available for purchase.

Usage

This manual should be used during:

- installation and commissioning, from lifting the product to its work site and securing it to the foundation, to making it ready for operation
- maintenance work
- repair work
- decommissioning work



Note

It is the responsibility of the integrator to conduct a risk assessment of the final application.

It is the responsibility of the integrator to provide safety and user guides for the robot system.

Who should read this manual?

This manual is intended for:

- installation personnel
 - maintenance personnel
 - repair personnel.
-

Prerequisites

A maintenance/repair/installation craftsman working with an ABB robot must:

- be trained by ABB and have the required knowledge of mechanical and electrical installation/repair/maintenance work.
 - be trained to respond to emergencies or abnormal situations.
-

Continues on next page

References

Documentation referred to in the manual, is listed in the table below.

Document name	Document ID
<i>Product manual, spare parts - IRB 6700/IRB 6700Inv</i>	3HAC044268-001
<i>Circuit diagram - IRB 6700 / IRB 6790</i>	3HAC043446-005
<i>Technical reference manual - Lubrication in gearboxes</i>	3HAC042927-001
<i>Product specification - IRB 6700</i> For OmniCore robots	3HAC080365-001
<i>Product specification - IRB 6700</i> For IRC5 robots	3HAC044265-001
<i>Directions for use - Fork lift accessory set 3HAC047054-001</i>	3HAC048484-002
<i>Product manual - DressPack/SpotPack IRB 6700</i>	3HAC044270-001
<i>Safety manual for robot - Manipulator and IRC5 or OmniCore controllerⁱ</i>	3HAC031045-001
<i>Product manual - OmniCore V250XT</i> For OmniCore robots	3HAC073447-001
<i>Product manual - IRC5</i> For IRC5 robots, with main computer DSQC1000.	3HAC047136-001
<i>Product manual - IRC5</i> For IRC5 robots, with main computer DSQC 639.	3HAC021313-001
<i>Operating manual - OmniCore</i>	3HAC065036-001
<i>Operating manual - IRC5 with FlexPendant</i>	3HAC050941-001
<i>Operating manual - Calibration Pendulum</i> For IRC5 robots	3HAC16578-1
<i>Technical reference manual - System parameters</i> For OmniCore robots	3HAC065041-001
<i>Technical reference manual - System parameters</i> For IRC5 robots	3HAC050948-001

ⁱ This manual contains all safety instructions from the product manuals for the manipulators and the controllers.

Revisions

Revision	Description
-	First edition.
A	The following updates are done in this revision: <ul style="list-style-type: none"> The variants IRB 6700-200/2.60 and IRB 6700-155/2.85 are added. Some illustrations showing IRB 6640 are replaced with IRB 6700. The information is updated in <i>Lifting with fork lift accessory</i>. ABB recommends that the fork lift accessories are removed before powering up the robot.
B	The following updates are done in this revision: <ul style="list-style-type: none"> The protection type <i>Foundry Plus</i> is added throughout the manual.

Continues on next page

Revision	Description
C	<p>The following updates are done in this revision:</p> <ul style="list-style-type: none"> • The variants IRB 6700-300/2.70 and -245/3.00 are added throughout the manual. • The maximum allowed deviation in levelness of the base plate and foundation is changed, see Securing the base plate on page 64. • Added information about which axes are affected by non-integer gear ratio, see Updating revolution counters on page 775. • Removed faulty listed washer from consumables tabe, section Replacing the upper arm on page 284. • Added tightening torque for R1.SMB and 7th axis connector, ses Refitting the cable harness on page 243. • Measurements added for transport support used on variants IRB 6700-300/2.70 and -245/3.00.
D	<p>The following updates are done in this revision:</p> <ul style="list-style-type: none"> • Number of attachment screws was wrong in Orienting and securing the robot on page 73. Corrected to 8 pcs. • Added an alternative tightening torque for robot attachment bolts, see Orienting and securing the robot on page 73. • Added information about guide pins, both when securing the robot to the base plate and when securing it to a track motion carriage, see Orienting and securing the robot on page 73. • Updated base plate drawings and added information regarding guide pins, see Securing the base plate on page 64. • Thread lines were missing. Now added in figure. • Figure updated so locating hole is shown at "12 o'clock".
E	<p>The following updates are done in this revision:</p> <ul style="list-style-type: none"> • Information regarding how to read the procedures in this product manual are updated, see How to read the product manual on page 17. • New standard calibration method is introduced (Axis Calibration). See Calibration on page 767. • Information added regarding compatibility between new design of turning disk and the axis-6 synchronization mark plate, see Replacing the synchronization mark plate on page 355. • Flattened cylindrical guide pin is removed for the base plate, replaced with a cylindrical. See Securing the base plate on page 64. • O-ring type changed in Replacing the axis-1 gearbox (IRB 6700 - 300/2.70, IRB 6700 - 245/3.00) on page 603. • Sections "Inspecting oil level" and "Changing oil in gear box" are updated with information for 300/2.70 and 245/3.00.

Continues on next page

Revision	Description
F	<p>The following updates are done in this revision:</p> <ul style="list-style-type: none"> • Corrected the article number for the rotation tool to 3HAB7887-1. • Removed the tool measuring ring for radial seal from special tools list, since it is not used for the robot. • Removed the article number for the leak-down tester, since it is not a purchable equipment. • Removed the article number for the threaded bar used for pressing the rear balancing device bearing in place, since it is not a purchable equipment. • Corrected the article number for the fork lift from 3HAC047054-002 to 3HAC047054-003. • Edited information regarding deciding calibration routine in each repair section. • Added a warning that calibration pin must be inserted in the calibration bushing until it snaps, see Description of Axis Calibration on page 781. • Added warning regarding risk of pinching, in Description of Axis Calibration on page 781. • Added information about inspection of calibration tool prior to usage, see Examining the calibration tool on page 784. • Added information about the calibration procedure, see Overview of the calibration procedure on the FlexPendant on page 787, Restarting an interrupted calibration procedure on page 789. • Added information about Axis Calibration when SafeMove is installed, see Axis Calibration with SafeMove option on page 789.
G	<p>The following updates are done in this revision:</p> <ul style="list-style-type: none"> • Removal tools for removing the motors are updated. New article numbers for the tools.
H	<p>Published in release R16.2. The following updates are made in this revision:</p> <ul style="list-style-type: none"> • Drawing of base plate is not available for purchase, faulty information removed in Securing the base plate on page 64. • Type B motors are introduced throughout the manual. • The figure of the turning disc is updated, the throughout holes are removed and a table note is added, see Tool flange, standard on page 84. • Illustration regarding centering diameters on tool flange updated.
J	<p>Published in release R17.1. The following updates are made in this revision:</p> <ul style="list-style-type: none"> • Illustration for "Tool flange, standard" is updated. • Bending radius for static floor cables added. • Instructions for how to install the fork lift accessory set are removed from the manual. The instructions are found in the user documentation, enclosed with the fork lift accessory. • Grease trade name changed (was Optimol PD0 - is Tribol GR 100-0 PD) • Article number for axis-4 motor o-ring is corrected. • Spare part numbers for movable mechanical stop set axis 1 is changed, and one new number is added. • Motors updated, M12 instead of M14 holes on IRB6700 for removal tool. • Quality recommendations on foundation removed from manual.

Revision	Description
K	<p>Published in release R17.2. The following updates are made in this revision:</p> <ul style="list-style-type: none"> • Caution about removing metal residues added in sections about SMB boards. • Information about Minimum resonance frequency added. • Bending radius for static floor cables added. • Applicable standards updated • Added text regarding overhaul in section specification of maintenance intervals. • Section Start of robot in cold environments on page 101 added. • Added information and dimensions of cylindrical and flattened cylindrical guide pins used for securing the robot. • Added new length of screws for securing the robot to a track motion. • Updated information regarding replacement of brake release board. • Updated information regarding disconnecting and reconnecting battery cable to serial measurement board. • Definition of reference calibration clarified. • Added information about flange sealant between axis-1 gearbox and base.
L	<p>Published in release R18.1. The following updates are made in this revision:</p> <ul style="list-style-type: none"> • Information added about fatigue to Axis Calibration tool, see Calibration tools for Axis Calibration on page 784. • Added sections in General procedures on page 186. • Corrected the length of attachment screws for axis-1 and axis-2 motors. • Guide tool for refitting the axis-1 gearbox is added to the repair procedure and list of special tools. • Safety restructured. • Changed specification for axis-2 position before usage of distance tool on the balancing device. • The procedure for replacing the axis-3 gearbox is changed to using a loose pinion as a tool during refitting of the upper arm. • Added photos showing the appearance of the protection filter and the transparent plug on motor oil evacuation hole. • Note added to calibration chapter to emphasize the requirement of equally dressed robot when using previously created reference calibration values. • Information about myABB Business Portal added. • Added Nickel in Environmental information. • Installation information of cooling fan for the axis-1 motor added.
M	<p>Published in release R18.2. The following updates are made in this revision:</p> <ul style="list-style-type: none"> • Added article number for axis-3 pinion tool.
N	<p>Published in release R18.2. The following updates are made in this revision:</p> <ul style="list-style-type: none"> • Updated references.

Revision	Description
P	<p>Published in release 19B. The following updates are made in this revision:</p> <ul style="list-style-type: none"> • New touch up color Graphite White available. See Cut the paint or surface on the robot before replacing parts on page 192. • New article numbers for manipulator cables in section Robot cabling and connection points on page 90. • Added new o-ring for axis-3 gearbox for IRB 6700 - 200/2.60, IRB 6700 - 155/2.85.
Q	<p>Published in release 19D. The following updates are made in this revision:</p> <ul style="list-style-type: none"> • Added references to DressPack manual in Robot cabling and connection points on page 90. • Corrected article number for guide pin M12x200 and removal tool M12. Deleted guide pin M12x250 from special tool list.
R	<p>Published in release 20A. The following updates are made in this revision:</p> <ul style="list-style-type: none"> • Added new protection plug for the front link ear. • Replaced article number and name of grease, previously 3HAB3537-1. • Clarified and added information in mounting instructions for rotating sealings, see Mounting instructions for sealings on page 189. • Clarified text about position of robot and added table with dependencies between axes during Axis Calibration.
S	<p>Published in release 20B. The following updates are made in this revision:</p> <ul style="list-style-type: none"> • Added information about Wrist Optimization in calibration chapter.
T	<p>Published in release 20C. The following updates are made in this revision:</p> <ul style="list-style-type: none"> • New press equipment for unloading balancing device introduced. New article number. User instructions for the equipment are enclosed with the tool. • Pallet removed from required tools tables.
U	<p>Published in release 20D. The following updates are made in this revision:</p> <ul style="list-style-type: none"> • Added o-ring for axis-6 gearbox, for IRB 6700 - 300/2.70, IRB 6700 - 245/3.00 and IRB 6700 - 200/2.60, IRB 6700 - 155/2.85. • Added o-ring for axis-6 motor flange, for IRB 6700 - 200/2.60, IRB 6700 - 155/2.85.
V	<p>Published in release 21C. The following updates are made in this revision:</p> <ul style="list-style-type: none"> • User instructions for the dismantle and mounting tool (3HAC028920-001) is now enclosed with the toolkit. User instructions are removed from this manual. • Section Lifting the robot with lifting accessory added to Lifting the robot on page 66. • Text regarding fastener quality is updated, see Fastener quality on page 85. • Info about option Extended working range included, see Extended working range, axis 1 (option) on page 86.
W	<p>Published in release 21D. The following updates are made in this revision:</p> <ul style="list-style-type: none"> • Added information for the OmniCore robot controller.
X	<p>Published in release 22A. The following updates are made in this revision:</p> <ul style="list-style-type: none"> • Oil change interval is corrected in maintenance schedule. • Updated information about Gleitmo treated screws, see Screw joints on page 810. • Updated image of roundslings attached to lifting shackle. • Removed information about inspecting fork lift accessories. Information is found in enclosed documentation for the fork lift accessories.

Product documentation

Categories for user documentation from ABB Robotics

The user documentation from ABB Robotics is divided into a number of categories. This listing is based on the type of information in the documents, regardless of whether the products are standard or optional.



Tip

All documents can be found via myABB Business Portal, www.abb.com/myABB.

Product manuals

Manipulators, controllers, DressPack/SpotPack, and most other hardware is delivered with a **Product manual** that generally contains:

- Safety information.
 - Installation and commissioning (descriptions of mechanical installation or electrical connections).
 - Maintenance (descriptions of all required preventive maintenance procedures including intervals and expected life time of parts).
 - Repair (descriptions of all recommended repair procedures including spare parts).
 - Calibration.
 - Decommissioning.
 - Reference information (safety standards, unit conversions, screw joints, lists of tools).
 - Spare parts list with corresponding figures (or references to separate spare parts lists).
 - References to circuit diagrams.
-

Technical reference manuals

The technical reference manuals describe reference information for robotics products, for example lubrication, the RAPID language, and system parameters.

Application manuals

Specific applications (for example software or hardware options) are described in **Application manuals**. An application manual can describe one or several applications.

An application manual generally contains information about:

- The purpose of the application (what it does and when it is useful).
- What is included (for example cables, I/O boards, RAPID instructions, system parameters, software).
- How to install included or required hardware.
- How to use the application.
- Examples of how to use the application.

Continues on next page

Operating manuals

The operating manuals describe hands-on handling of the products. The manuals are aimed at those having first-hand operational contact with the product, that is production cell operators, programmers, and troubleshooters.

How to read the product manual

Reading the procedures

The procedures contain all information required for the installation or service activity and can be printed out separately when needed for a certain service procedure.

Safety information

The manual includes a separate safety chapter that must be read through before proceeding with any service or installation procedures. All procedures also include specific safety information when dangerous steps are to be performed.

Read more in the chapter [Safety on page 19](#).

Illustrations

The product is illustrated with general figures that does not take painting or protection type in consideration.

Likewise, certain work methods or general information that is valid for several product models, can be illustrated with illustrations that show a different product model than the one that is described in the current manual.

This page is intentionally left blank

1 Safety

1.1 Safety information

1.1.1 Limitation of liability

Limitation of liability

Any information given in this manual regarding safety must not be construed as a warranty by ABB that the industrial robot will not cause injury or damage even if all safety instructions are complied with.

The information does not cover how to design, install and operate a robot system, nor does it cover all peripheral equipment that can influence the safety of the robot system.

In particular, liability cannot be accepted if injury or damage has been caused for any of the following reasons:

- Use of the robot in other ways than intended.
- Incorrect operation or maintenance.
- Operation of the robot when the safety devices are defective, not in their intended location or in any other way not working.
- When instructions for operation and maintenance are not followed.
- Non-authorized design modifications of the robot.
- Repairs on the robot and its spare parts carried out by in-experienced or non-qualified personnel.
- Foreign objects.
- Force majeure.

Spare parts and equipment

ABB supplies original spare parts and equipment which have been tested and approved. The installation and/or use of non-original spare parts and equipment can negatively affect the safety, function, performance, and structural properties of the robot. ABB is not liable for damages caused by the use of non-original spare parts and equipment.

1 Safety

1.1.2 Requirements on personnel

1.1.2 Requirements on personnel

General

Only personnel with appropriate training are allowed to install, maintain, service, repair, and use the robot. This includes electrical, mechanical, hydraulics, pneumatics, and other hazards identified in the risk assessment.

Persons who are under the influence of alcohol, drugs or any other intoxicating substances are not allowed to install, maintain, service, repair, or use the robot.

The plant liable must make sure that the personnel is trained on the robot, and on responding to emergency or abnormal situations.

Personal protective equipment

Use personal protective equipment, as stated in the instructions.

1.2 Safety signals and symbols

1.2.1 Safety signals in the manual







Introduction to safety signals

This section specifies all safety signals used in the user manuals. Each signal consists of:

- A caption specifying the hazard level (DANGER, WARNING, or CAUTION) and the type of hazard.
- Instruction about how to reduce the hazard to an acceptable level.
- A brief description of remaining hazards, if not adequately reduced.

Hazard levels

The table below defines the captions specifying the hazard levels used throughout this manual.

Symbol	Designation	Significance
	DANGER	Signal word used to indicate an imminently hazardous situation which, if not avoided, will result in serious injury.
	WARNING	Signal word used to indicate a potentially hazardous situation which, if not avoided, could result in serious injury.
	ELECTRICAL SHOCK	Signal word used to indicate a potentially hazardous situation related to electrical hazards which, if not avoided, could result in serious injury.
	CAUTION	Signal word used to indicate a potentially hazardous situation which, if not avoided, could result in slight injury.
	ELECTROSTATIC DISCHARGE (ESD)	Signal word used to indicate a potentially hazardous situation which, if not avoided, could result in severe damage to the product.
	NOTE	Signal word used to indicate important facts and conditions.

Continues on next page

1 Safety

1.2.1 Safety signals in the manual

Continued

Symbol	Designation	Significance
	TIP	Signal word used to indicate where to find additional information or how to do an operation in an easier way.

1.2.2 Safety symbols on manipulator labels

Introduction to symbols

This section describes safety symbols used on labels (stickers) on the manipulator. Symbols are used in combinations on the labels, describing each specific warning. The descriptions in this section are generic, the labels can contain additional information such as values.



Note

The symbols on the labels on the product must be observed. Additional symbols added by the integrator must also be observed.



Types of symbols

Both the manipulator and the controller are marked with symbols, containing important information about the product. This is important for all personnel handling the robot, for example during installation, service, or operation.

The safety labels are language independent, they only use graphics. See [Symbols on safety labels on page 23](#).

The information labels can contain information in text.

Symbols on safety labels



Symbol	Description
 xx0900000812	Warning! Warns that an accident <i>may</i> occur if the instructions are not followed that can lead to serious injury, possibly fatal, and/or great damage to the product. It applies to warnings that apply to danger with, for example, contact with high voltage electrical units, explosion or fire risk, risk of poisonous gases, risk of crushing, impact, fall from height, etc.
 xx0900000811	Caution! Warns that an accident may occur if the instructions are not followed that can result in injury and/or damage to the product. It also applies to warnings of risks that include burns, eye injury, skin injury, hearing damage, crushing or slipping, tripping, impact, fall from height, etc. Furthermore, it applies to warnings that include function requirements when fitting and removing equipment where there is a risk of damaging the product or causing a breakdown.
 xx0900000839	Prohibition Used in combinations with other symbols.

Continues on next page

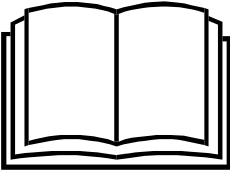
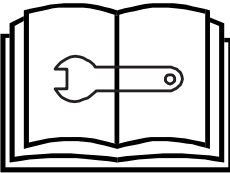
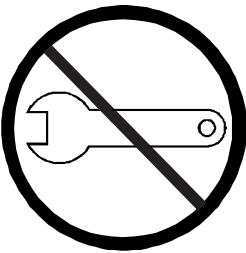
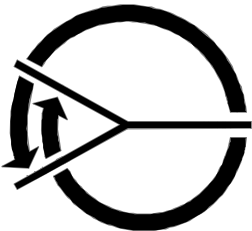

1 Safety

1.2.2 Safety symbols on manipulator labels

Continued

Symbol	Description
 xx0900000813	See user documentation Read user documentation for details. Which manual to read is defined by the symbol: <ul style="list-style-type: none">• No text: <i>Product manual</i>.• EPS: <i>Application manual - Electronic Position Switches</i>.
 xx0900000816	Before disassembly, see product manual
 xx0900000815	Do not disassemble Disassembling this part can cause injury.
 xx0900000814	Extended rotation This axis has extended rotation (working area) compared to standard.
 xx0900000808	Brake release Pressing this button will release the brakes. This means that the robot arm can fall down.

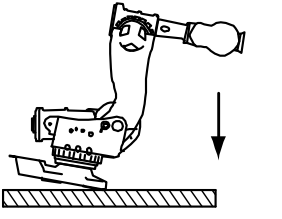

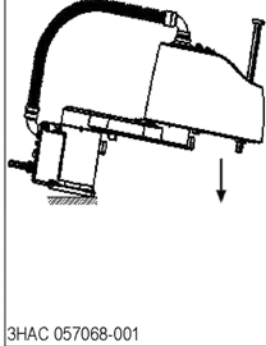
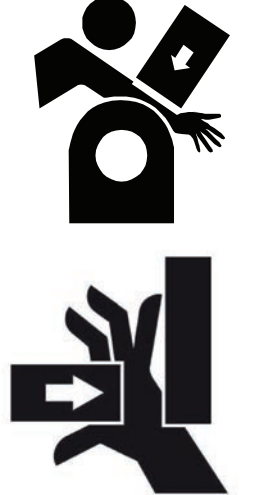
Continues on next page

Symbol	Description
 <p>xx0900000810</p>   <p>3HAC 057068-001</p> <p>xx1500002402</p>	<p>Tip risk when loosening bolts The robot can tip over if the bolts are not securely fastened.</p>
 <p>xx0900000817</p>	<p>Crush Risk of crush injuries.</p>





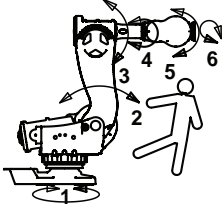
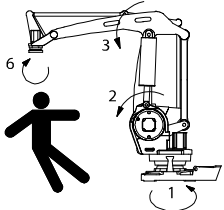
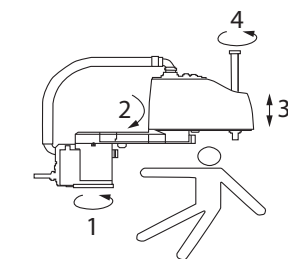

1 Safety

1.2.2 Safety symbols on manipulator labels

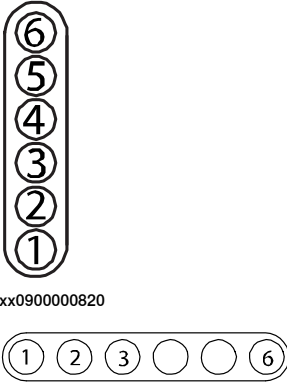
Continued

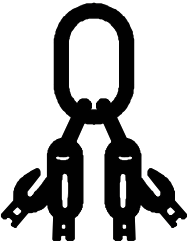
Symbol	Description
 xx0900000818  xx1300001087	Heat Risk of heat that can cause burns. (Both signs are used)
 xx0900000819  xx1000001141  xx1500002616	Moving robot The robot can move unexpectedly.

Continues on next page





Symbol	Description
 <p>xx0900000820</p> <p>xx1000001140</p>	<p>Brake release buttons</p>
 <p>xx0900000821</p>	<p>Lifting bolt</p>
 <p>xx1000001242</p>	<p>Chain sling with shortener</p>
 <p>xx0900000822</p>	<p>Lifting of robot</p>
 <p>xx0900000823</p>	<p>Oil Can be used in combination with prohibition if oil is not allowed.</p>
 <p>xx0900000824</p>	<p>Mechanical stop</p>

Continues on next page

1 Safety

1.2.2 Safety symbols on manipulator labels

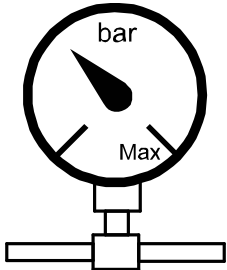
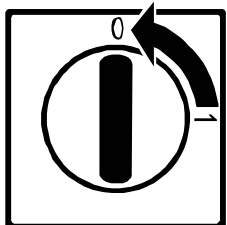
Continued

Symbol	Description
 xx1000001144	No mechanical stop
 xx0900000825	Stored energy Warns that this part contains stored energy. Used in combination with <i>Do not disassemble</i> symbol.
 xx0900000826	Pressure Warns that this part is pressurized. Usually contains additional text with the pressure level.
 xx0900000827	Shut off with handle Use the power switch on the controller.
 xx1400002648	Do not step Warns that stepping on these parts can cause damage to the parts.

1.3 Robot stopping functions

Protective stop and emergency stop

The protective stops and emergency stops are described in the product manual for the controller.

For more information see:

- *Product manual - OmniCore V250XT*
- *Product manual - IRC5*
- *Product manual - IRC5 Panel Mounted Controller*

1 Safety

1.4 Safety during installation and commissioning

1.4 Safety during installation and commissioning

National or regional regulations

The integrator of the robot system is responsible for the safety of the robot system.

The integrator is responsible that the robot system is designed and installed in accordance with the safety requirements set forth in the applicable national and regional standards and regulations.

The integrator of the robot system is required to perform a risk assessment.

Layout

The robot integrated to a robot system shall be designed to allow safe access to all spaces during installation, operation, maintenance, and repair.

If robot movement can be initiated from an external control panel then an emergency stop must also be available.

If the manipulator is delivered with mechanical stops, these can be used for reducing the working space.

A perimeter safeguarding, for example a fence, shall be dimensioned to withstand the following:

- The force of the manipulator.
- The force of the load handled by the robot if dropped or released at maximum speed.
- The maximum possible impact caused by a breaking or malfunctioning rotating tool or other device fitted to the robot.

The maximum TCP speed and the maximum velocity of the robot axes are detailed in the section *Robot motion* in the product specification for the respective manipulator.

Consider exposure to hazards, such as slipping, tripping, and falling.

Hazards due to the working position and posture for a person working with or near the robot shall be considered.

Hazards due to noise emission from the robot needs to be considered.

Consider hazards from other equipment in the robot system, for example, that guards remain active until identified hazards are reduced to an acceptable level.

Allergenic material

See [Environmental information on page 799](#) for specification of allergenic materials in the product, if any.

Securing the robot to the foundation

The robot must be properly fixed to its foundation/support, as described in the respective product manual.

When the robot is installed at a height, hanging, or other than mounted directly on the floor, there will be additional hazards.

Continues on next page

Electrical safety

Incoming mains must be installed to fulfill national regulations.

The power supply wiring to the robot must be sufficiently fused and if necessary, it must be possible to disconnect it manually from the mains power.

The power to the robot must be turned off with the main switch and the mains power disconnected when performing work inside the controller cabinet. Lock and tag shall be considered.

Harnesses between controller and manipulator shall be fixed and protected to avoid tripping and wear.

Wherever possible, power on/off or rebooting the robot controller shall be performed with all persons outside the safeguarded space.



Note

Use a CARBON DIOXIDE (CO₂) extinguisher in the event of a fire in the robot.

Safety devices

The integrator is responsible for that the safety devices necessary to protect people working with the robot system are designed and installed correctly.

When integrating the robot with external devices to a robot system:

- The integrator of the robot system must ensure that emergency stop functions are interlocked in accordance with applicable standards.
- The integrator of the robot system must ensure that safety functions are interlocked in accordance with applicable standards.

Other hazards

A robot may perform unexpected limited movement.



WARNING

Manipulator movements can cause serious injuries on users and may damage equipment.

The risk assessment should also consider other hazards arising from the application, such as, but not limited to:

- Water
- Compressed air
- Hydraulics

End-effector hazards require particular attention for applications which involve close human collaboration with the robot.

Continues on next page

1 Safety

1.4 Safety during installation and commissioning

Continued

Pneumatic or hydraulic related hazards



Note

The pressure in the complete pneumatic or hydraulic systems must be released before service and maintenance.

All components in the robot system that remain pressurized after switching off the power to the robot must be marked with clearly visible drain facilities and a warning sign that indicates the hazard of stored energy.

Loss of pressure in the robot system may cause parts or objects to drop.

Dump valves should be used in case of emergency.

Shot bolts should be used to prevent tools, etc., from falling due to gravity.

All pipes, hoses, and connections have to be inspected regularly for leaks and damage. Damage must be repaired immediately.

Verify the safety functions

Before the robot system is put into operation, verify that the safety functions are working as intended and that any remaining hazards identified in the risk assessment are mitigated to an acceptable level.

1.5 Safety during operation

Automatic operation

Verify the application in the operating mode manual reduced speed, before changing mode to automatic and initiating automatic operation.

Unexpected movement of robot arm



WARNING

Hazards due to the use of brake release devices and/or gravity beneath the manipulator shall be considered.

A robot may perform unexpected limited movement.



WARNING

Manipulator movements can cause serious injuries on users and may damage equipment.

1 Safety

1.6.1 Safety during maintenance and repair

1.6 Safety during maintenance and repair

1.6.1 Safety during maintenance and repair

General

Corrective maintenance must only be carried out by personnel trained on the robot. Maintenance or repair must be done with all electrical, pneumatic, and hydraulic power switched off, that is, no remaining hazards.

Hazards due to stored mechanical energy in the manipulator for the purpose of counterbalancing axes must be considered before maintenance or repair.

Never use the robot as a ladder, which means, do not climb on the controller, manipulator, including motors, or other parts. There are hazards of slipping and falling. The robot might be damaged.

Make sure that there are no loose screws, turnings, or other unexpected parts remaining after work on the robot has been performed.

When the work is completed, verify that the safety functions are working as intended.

Hot surfaces

Surfaces can be hot after running the robot, and touching these may result in burns. Allow the surfaces to cool down before maintenance or repair.

Allergic reaction

Warning	Description	Elimination/Action
 Allergic reaction	When working with lubricants there is a risk of an allergic reaction.	Make sure that protective gear like goggles and gloves are always worn.

Gearbox lubricants (oil or grease)

When handling oil, grease, or other chemical substances the safety information of the respective manufacturer must be observed.









Note

Take special care when handling hot lubricants.

Warning	Description	Elimination/Action
 Hot oil or grease	Changing and draining gearbox oil or grease may require handling hot lubricant heated up to 90 °C.	Make sure that protective gear like goggles and gloves are always worn during this activity.

Continues on next page

Warning	Description	Elimination/Action
 Allergic reaction	When working with lubricants there is a risk of an allergic reaction.	Make sure that protective gear like goggles and gloves are always worn.
 Possible pressure build-up in gearbox	When opening the oil or grease plug, there may be pressure present in the gearbox, causing lubricant to spray from the opening.	Open the plug carefully and keep away from the opening. Do not overfill the gearbox when filling.
 Do not overfill	Overfilling of gearbox lubricant can lead to internal over-pressure inside the gearbox which in turn may: <ul style="list-style-type: none"> • damage seals and gaskets • completely press out seals and gaskets • prevent the robot from moving freely. 	Make sure not to overfill the gearbox when filling it with oil or grease. After filling, verify that the level is correct.
 Do not mix types of oil	Mixing types of oil may cause severe damage to the gearbox.	When filling gearbox oil, do not mix different types of oil unless specified in the instructions. Always use the type of oil specified for the product.
 Heat up the oil	Warm oil drains quicker than cold oil.	Run the robot before changing the gearbox oil, if possible.
 Specified amount depends on drained volume	The specified amount of oil or grease is based on the total volume of the gearbox. When changing the lubricant, the amount refilled may differ from the specified amount, depending on how much has previously been drained from the gearbox.	After filling, verify that the level is correct.
 Contaminated oil in gearboxes	For lifetime reasons always drain as much oil as possible from the gearbox. The magnetic oil plugs will gather residual metal chips.	

Hazards related to batteries

Under rated conditions, the electrode materials and liquid electrolyte in the batteries are sealed and not exposed to the outside.

Continues on next page

1 Safety

1.6.1 Safety during maintenance and repair

Continued

There is a hazard in case of abuse (mechanical, thermal, electrical) which leads to the activation of safety valves and/or the rupture of the battery container. As a result under certain circumstances, electrolyte leakage, electrode materials reaction with moisture/water or battery vent/explosion/fire may follow.

Do not short circuit, recharge, puncture, incinerate, crush, immerse, force discharge or expose to temperatures above the declared operating temperature range of the product. Risk of fire or explosion.

Operating temperatures are listed in [Operating conditions, robot on page 45](#).

See safety instructions for the batteries in *Material/product safety data sheet - Battery pack (3HAC043118-001)*.

Unexpected movement of robot arm



WARNING

Hazards due to the use of brake release devices and/or gravity beneath the manipulator shall be considered.

A robot may perform unexpected limited movement.



WARNING

Manipulator movements can cause serious injuries on users and may damage equipment.

Related information

See also the safety information related to installation and operation.

1.6.2 Emergency release of the robot axes

Description

In an emergency situation, the brakes on a robot axis can be released manually by pushing a brake release button.

How to release the brakes is described in the section:

- [Manually releasing the brakes on page 78](#).

The robot may be moved manually on smaller robot models, but larger models may require using an overhead crane or similar equipment.

Increased injury

Before releasing the brakes, make sure that the weight of the manipulator does not result in additional hazards, for example, even more severe injuries on a trapped person.



DANGER

When releasing the holding brakes, the robot axes may move very quickly and sometimes in unexpected ways.

Make sure no personnel is near or beneath the robot.

1 Safety

1.6.3 Brake testing

1.6.3 Brake testing

When to test

During operation, the holding brake of each axis normally wears down. A test can be performed to determine whether the brake can still perform its function.

How to test

The function of the holding brake of each axis motor may be verified as described below:

- 1 Run each axis to a position where the combined weight of the manipulator and any load is maximized (maximum static load).
- 2 Switch the motor to the MOTORS OFF.
- 3 Inspect and verify that the axis maintains its position.

If the manipulator does not change position as the motors are switched off, then the brake function is adequate.



Note

It is recommended to run the service routine *BrakeCheck* as part of the regular maintenance, see the operating manual for the robot controller.

For robots with the option SafeMove, the *Cyclic Brake Check* routine is recommended. See the manual for SafeMove in [References on page 10](#).

1.7 Safety during troubleshooting

General

When troubleshooting requires work with power switched on, special considerations must be taken:

- Safety circuits might be muted or disconnected.
- Electrical parts must be considered as *live*.
- The manipulator can move unexpectedly at any time.



DANGER

Troubleshooting on the controller while powered on must be performed by personnel trained by ABB or by ABB field engineers.



CAUTION

Risk of hot surfaces that can cause burns.

A risk assessment must be done to address both robot and robot system specific hazards.



WARNING

Hazards due to the use of brake release devices and/or gravity beneath the manipulator shall be considered.

A robot may perform unexpected limited movement.



WARNING

Manipulator movements can cause serious injuries on users and may damage equipment.

Related information

See also the safety information related to installation, operation, maintenance, and repair.

1 Safety

1.8 Safety during decommissioning

1.8 Safety during decommissioning

General

See section [Decommissioning on page 799](#).

Unexpected movement of robot arm



WARNING

Hazards due to the use of brake release devices and/or gravity beneath the manipulator shall be considered.

A robot may perform unexpected limited movement.



WARNING

Manipulator movements can cause serious injuries on users and may damage equipment.

2 Installation and commissioning

2.1 Introduction to installation and commissioning

General

This chapter contains assembly instructions and information for installing the IRB 6700 at the working site.

See also the product manual for the robot controller.

The installation must be done by qualified installation personnel in accordance with the safety requirements set forth in the applicable national and regional standards and regulations.

Safety information

Before any installation work is commenced, all safety information must be observed. There are general safety aspects that must be read through, as well as more specific safety information that describes the danger and safety risks when performing the procedures. Read the chapter [Safety on page 19](#) before performing any installation work.



Note

Always connect the IRB 6700 and the robot to protective earth and residual current device (RCD) before connecting to power and starting any installation work.

For more information see:

- *Product manual - OmniCore V250XT*
- *Product manual - IRC5*
- *Product manual - IRC5 Panel Mounted Controller*

2 Installation and commissioning

2.2.1 Pre-installation procedure

2.2 Unpacking

2.2.1 Pre-installation procedure

Introduction

This section is intended for use when unpacking and installing the robot for the first time. It also contains information useful during later re-installation of the robot.

Prerequisites for installation personnel

Installation personnel working with an ABB product must:

- be trained by ABB and have the required knowledge of mechanical and electrical installation/maintenance/repair work
- conform to all national and local codes.

Checking the pre-requisites for installation

	Action
1	Make a visual inspection of the packaging and make sure that nothing is damaged.
2	Remove the packaging.
3	Check for any visible transport damage.  Note Stop unpacking and contact ABB if transport damages are found.
4	Clean the unit with a lint-free cloth, if necessary.
5	Make sure that the lifting accessory used (if required) is suitable to handle the weight of the robot as specified in: Weight, robot on page 43
6	If the robot is not installed directly, it must be stored as described in: Storage conditions, robot on page 45
7	Make sure that the expected operating environment of the robot conforms to the specifications as described in: Operating conditions, robot on page 45
8	Before taking the robot to its installation site, make sure that the site conforms to: <ul style="list-style-type: none">• Loads on foundation, robot on page 43• Protection classes, robot on page 45• Requirements, foundation on page 44
9	Before moving the robot, please observe the stability of the robot: Risk of tipping/stability on page 52
10	When these prerequisites are met, the robot can be taken to its installation site as described in section: On-site installation on page 62
11	Install required equipment, if any. <ul style="list-style-type: none">• Signal lamp (option) on page 94

Continues on next page

Weight, robot

The table shows the weight of the robot.

The weight does not include the weight of the DressPack.

Robot model	Weight
IRB 6700	1300 kg



Note

The weight does not include tools and other equipment fitted on the robot.
The weight does not include the weight of the DressPack.

Loads on foundation, robot

The illustration shows the directions of the robots stress forces.

The directions are valid for all floor mounted, suspended and inverted robots.

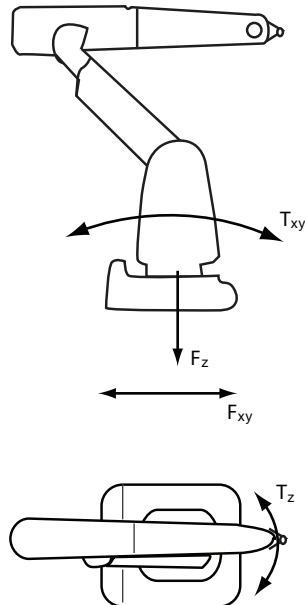

xx1100000521

F_{xy}	Force in any direction in the XY plane
F_z	Force in the Z plane
T_{xy}	Bending torque in any direction in the XY plane
T_z	Bending torque in the Z plane

The table shows the various forces and torques working on the robot during different kinds of operation.



Note

These forces and torques are extreme values that are rarely encountered during operation. The values also never reach their maximum at the same time!

Continues on next page

2 Installation and commissioning

2.2.1 Pre-installation procedure

Continued



WARNING

The robot installation is restricted to the mounting options given in following load table(s).

Floor mounted

Force	Endurance load (in operation)	Max. load (emergency stop)
Force xy	$\pm 7.4 \text{ kN}^i / \pm 8.7 \text{ kN}^{ii}$	$\pm 19.8 \text{ kN}^i / \pm 21.8 \text{ kN}^{ii}$
Force z	$14.6 \pm 4.5 \text{ kN}^i / 18.0 \pm 5.4 \text{ kN}^{ii}$	$14.6 \pm 15.7 \text{ kN}^i / 18.0 \pm 17.4 \text{ kN}^{ii}$
Torque xy	$\pm 21.0 \text{ kNm}^i / \pm 24.9 \text{ kNm}^{ii}$	$\pm 37.1 \text{ kNm}^i / \pm 45.3 \text{ kNm}^{ii}$
Torque z	$\pm 5.0 \text{ kNm}^i / \pm 6.5 \text{ kNm}^{ii}$	$\pm 11.4 \text{ kNm}^i / \pm 15.5 \text{ kNm}^{ii}$

ⁱ Valid for IRB 6700-235, -205, -175, -150, -200, -155.

Valid for IRB 6700-235/2.65, 205/2.80, 200/2.60, 175/3.05, 155/2.85, 150/3.20, 220/2.65 LID, 200/2.80 LID, 175/2.60 LID, 155/3.05 LID, 140/2.85 LID, 145/3.20 LID.

ⁱⁱ Valid for IRB 6700-300, -245.

Valid for IRB 6700-300/2.70, -245/3.00, 270/2.70 LID, 220/3.00 LID.

Requirements, foundation

The table shows the requirements for the foundation where the weight of the installed robot is included:

Requirement	Value	Note
Flatness of foundation surface	0.3 mm	Flat foundations give better repeatability of the resolver calibration compared to original settings on delivery from ABB. The value for levelness aims at the circumstance of the anchoring points in the robot base. In order to compensate for an uneven surface, the robot can be recalibrated during installation. If resolver/encoder calibration is changed this will influence the absolute accuracy.
Maximum tilt	0°	
Minimum resonance frequency	22 Hz  Note It may affect the manipulator lifetime to have a lower resonance frequency than recommended.	The value is recommended for optimal performance. Due to foundation stiffness, consider robot mass including equipment. ⁱ For information about compensating for foundation flexibility, see the application manual of the controller software, section <i>Motion Process Mode</i> .

ⁱ The minimum resonance frequency given should be interpreted as the frequency of the robot mass/inertia, robot assumed stiff, when a foundation translational/torsional elasticity is added, i.e., the stiffness of the pedestal where the robot is mounted. The minimum resonance frequency should not be interpreted as the resonance frequency of the building, floor etc. For example, if the equivalent mass of the floor is very high, it will not affect robot movement, even if the frequency is well below the stated frequency. The robot should be mounted as rigid as possible to the floor.

Disturbances from other machinery will affect the robot and the tool accuracy. The robot has resonance frequencies in the region 10 – 20 Hz and disturbances in this region will be amplified, although somewhat damped by the servo control. This might be a problem, depending on the requirements from the applications. If this is a problem, the robot needs to be isolated from the environment.

Continues on next page

Storage conditions, robot

The table shows the allowed storage conditions for the robot:

Parameter	Value
Minimum ambient temperature	-25 °C (-13 °F)
Maximum ambient temperature	+55 °C (+131 °F)
Maximum ambient temperature (less than 24 hrs)	+70 °C (+158 °F)
Maximum ambient humidity	Maximum 95% at constant temperature.

Operating conditions, robot

The table shows the allowed operating conditions for the robot:

Parameter	Value
Minimum ambient temperature	+5 °C ⁱ (41 °F)
Maximum ambient temperature	+50 °C (122 °F)
Maximum ambient humidity	Maximum 95% at constant temperature.

ⁱ At low environmental temperature (below 10 °C) a warm-up phase is recommended to be run with the robot. Otherwise there is a risk that the robot stops or runs with lower performance due to temperature dependent oil and grease viscosity.

Protection classes, robot

The table shows the available protection types of the robot, with the corresponding protection class.

Protection type	Protection class ¹
Manipulator, protection type Standard	IP67
Manipulator, protection type Foundry Plus	IP67

2 Installation and commissioning

2.2.2 Working range

2.2.2 Working range

Working range

Axis	Type of motion	Working range	Note
Axis 1	Rotation motion	$\pm 170^\circ$ or $\pm 220^\circ$ (option)	
Axis 2	Arm motion	$-65^\circ / +85^\circ$ ⁱ	
Axis 3	Arm motion	$-180^\circ / +70^\circ$	
Axis 4	Wrist motion	$\pm 300^\circ$	Default value.
Axis 5	Bend motion	$\pm 130^\circ$ ⁱⁱ	
Axis 6	Turn motion	$\pm 360^\circ$ ⁱⁱⁱ	Default value.
		± 93.7 revolutions	Maximum value. The default working range for axis 6 can be extended by changing parameter values in the software.

ⁱ Working range for variants IRB 6700 - 300/2.70 and - 245/3.00:

+85° to -65° when axis 3 is within +70° to -45°

+85° to -58° when axis 3 is within +70° to -180°

ⁱⁱ Working range +120° to -120° for robots with LeanID, option 780-4LID Variants.

ⁱⁱⁱ Working range +220° to -220° for robots with LeanID, option 780-4LID Variants.

Working range axis 5 and axis 6 for LeanID, option 780-4

Allowed working area for axis 6 related to axis 5 position is shown in the figure below.

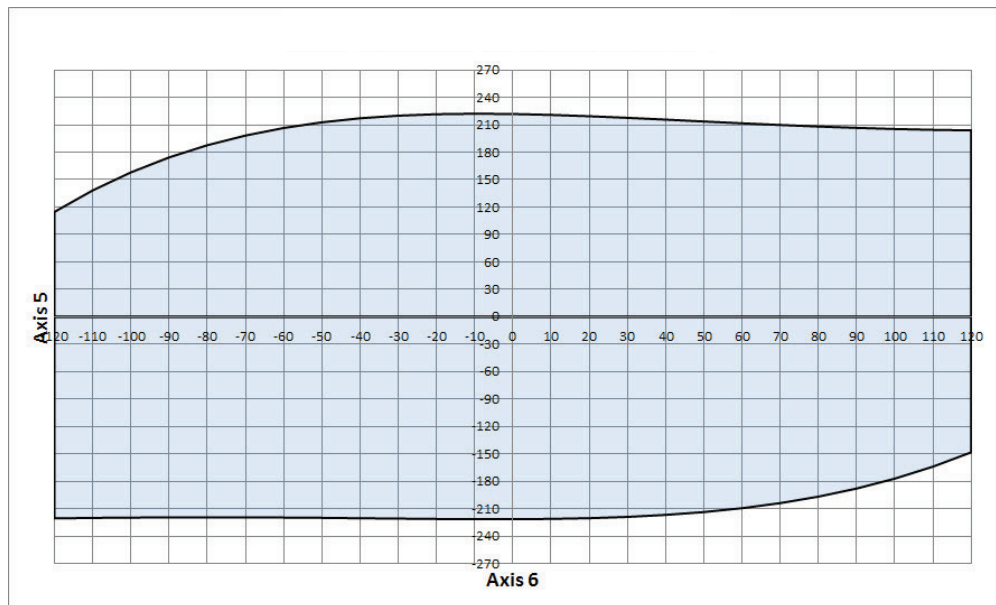

Continues on next page

Illustration, working range IRB 6700 - 235/2.65

This illustration shows the unrestricted working range of the robot.

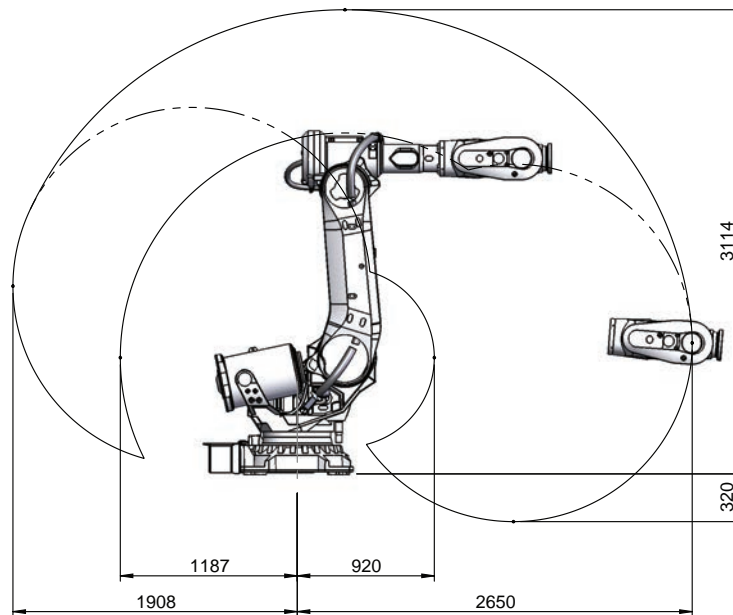

Robot type	Handling capacity	Reach
IRB 6700	235 kg	2.65 m

Illustration, working range IRB 6700 - 205/2.80

This illustration shows the unrestricted working range of the robot.

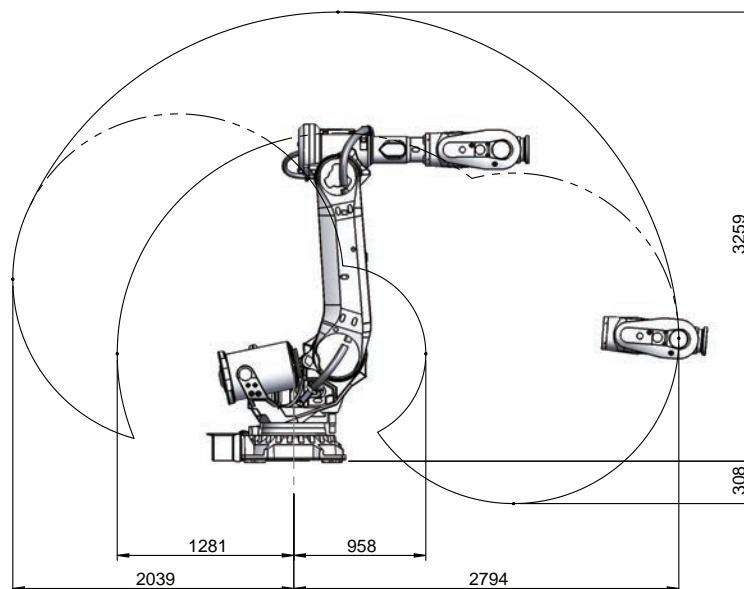

Robot type	Handling capacity	Reach
IRB 6700	205 kg	2.80 m

Continues on next page

2 Installation and commissioning

2.2.2 Working range

Continued

Illustration, working range IRB 6700 - 175/3.05

This illustration shows the unrestricted working range of the robot.

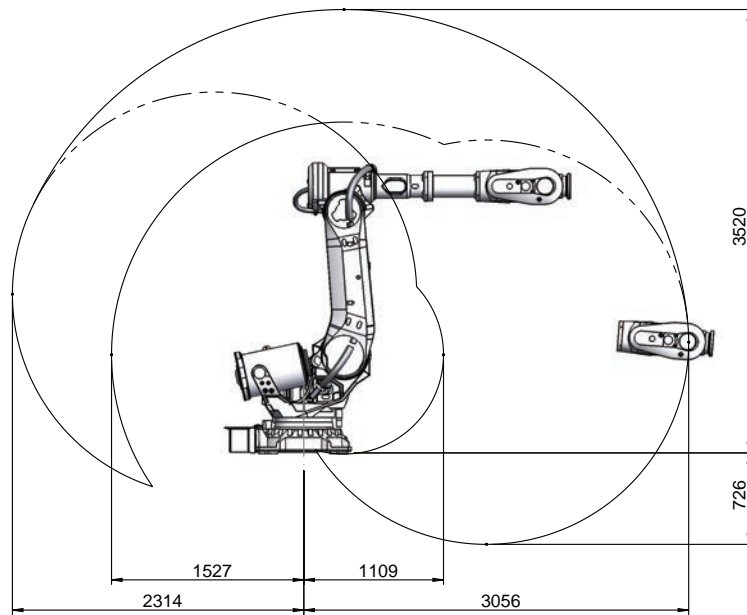

Robot type	Handling capacity	Reach
IRB 6700	175 kg	3.05 m

Illustration, working range IRB 6700 - 150/3.20

This illustration shows the unrestricted working range of the robot.

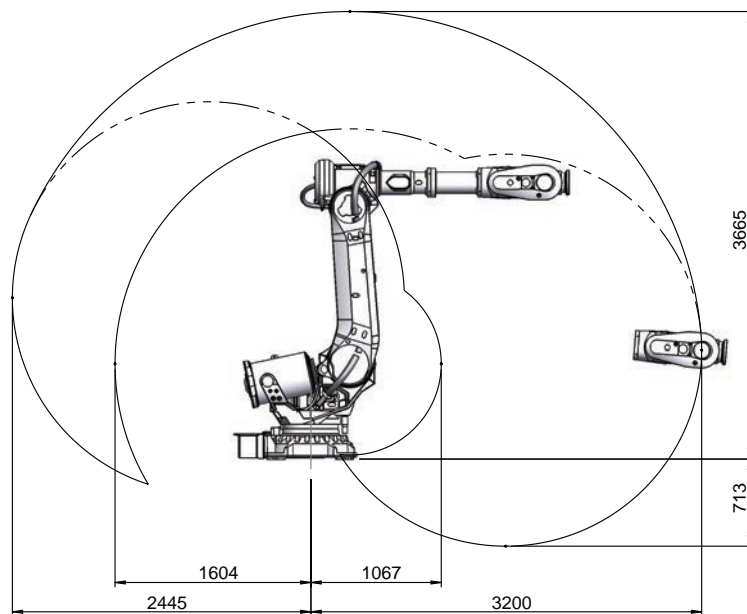

Robot type	Handling capacity	Reach
IRB 6700	150 kg	3.20 m

Continues on next page

Illustration, working range IRB 6700 - 200/2.60

This illustration shows the unrestricted working range of the robot.

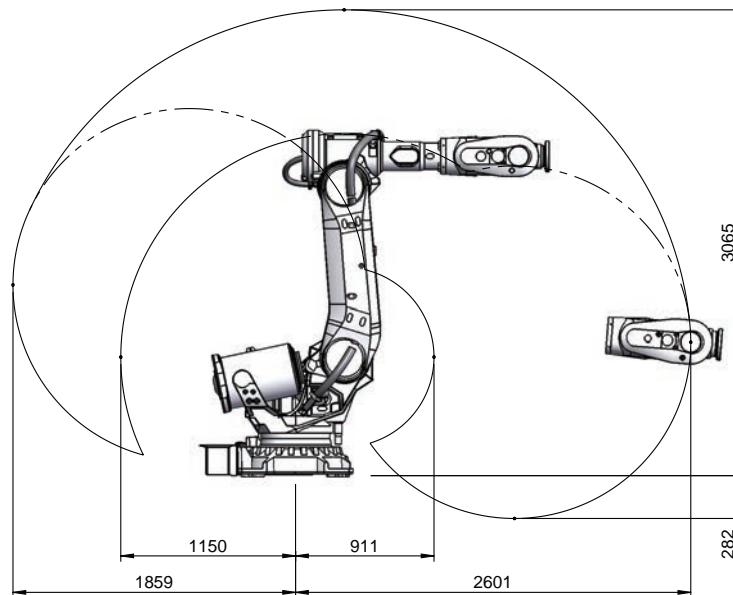

Robot type	Handling capacity	Reach
IRB 6700	200 kg	2.60 m

Illustration, working range IRB 6700 - 155/2.85

This illustration shows the unrestricted working range of the robot.

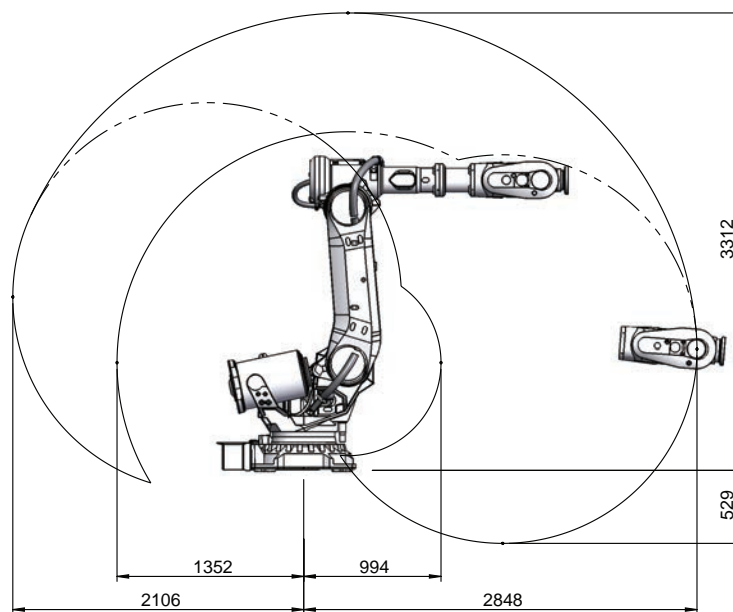

Robot type	Handling capacity	Reach
IRB 6700	155 kg	2.85 m

Continues on next page

2 Installation and commissioning

2.2.2 Working range

Continued

Illustration, working range IRB 6700 - 300/2.70

This illustration shows the unrestricted working range of the robot.

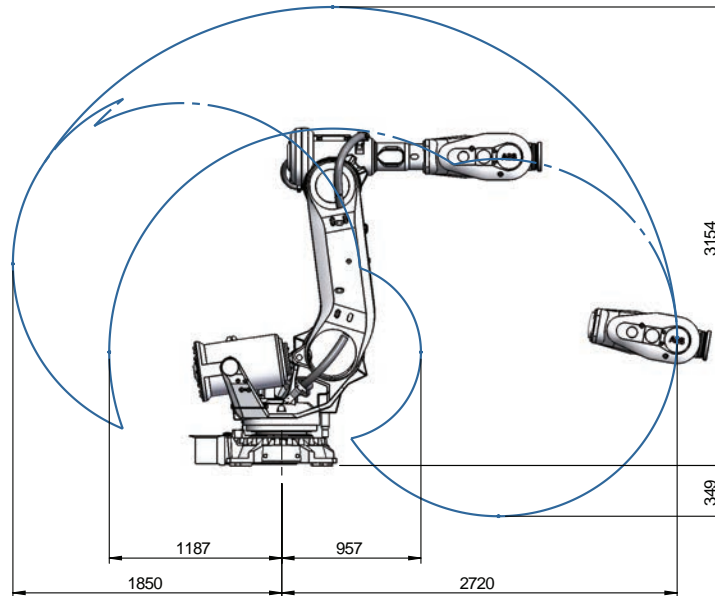

Robot type	Handling capacity	Reach
IRB 6700	300 kg	2.70 m

Illustration, working range IRB 6700 - 245/3.00

This illustration shows the unrestricted working range of the robot.

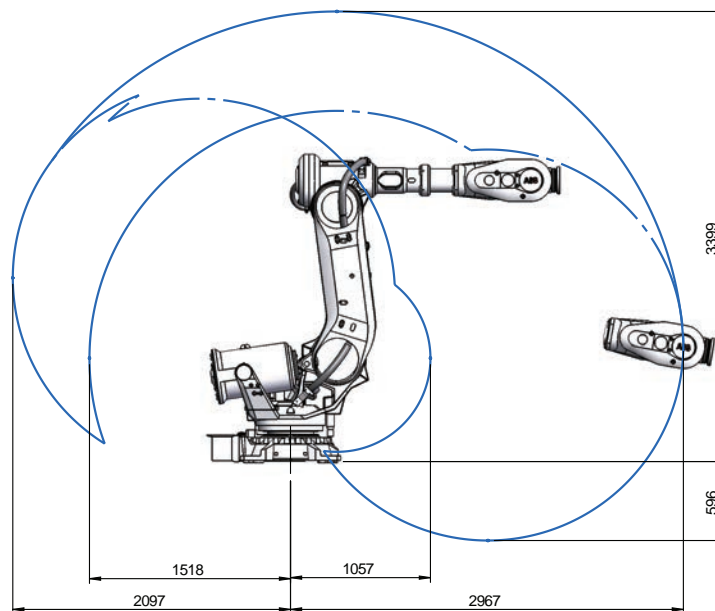

Robot type	Handling capacity	Reach
IRB 6700	245 kg	3.00 m

Continues on next page

Turning radius axis 1

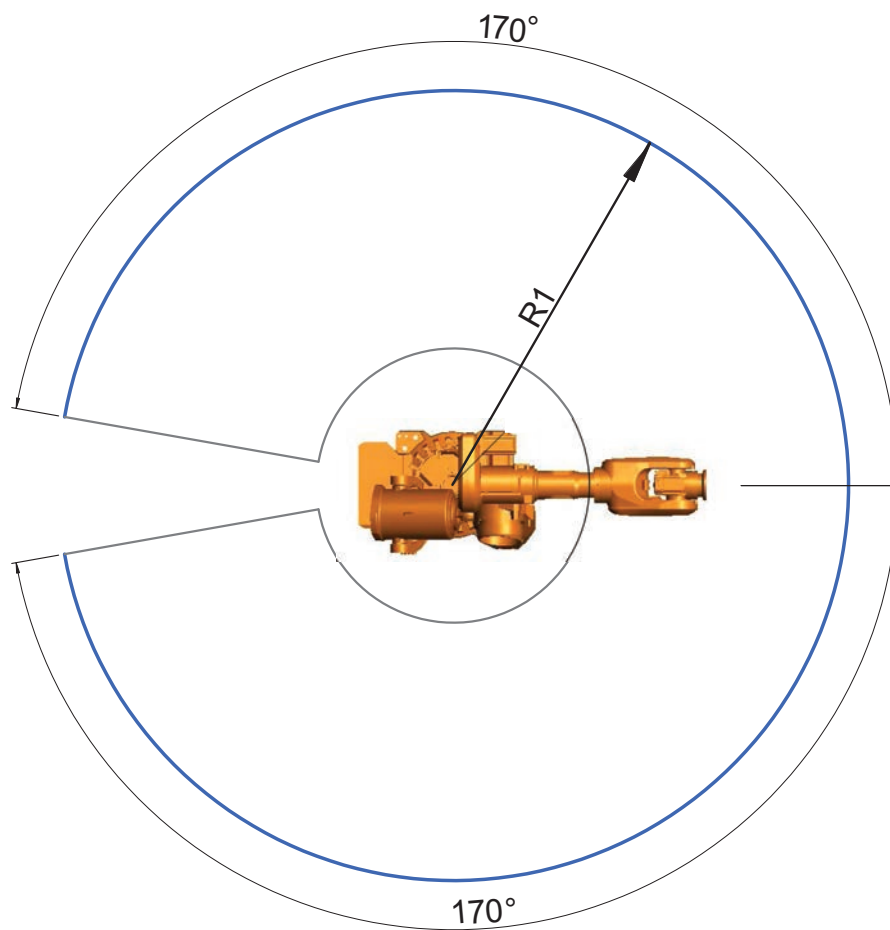

xx1300001082

Robot variant	R1 (mm)
IRB 6700 - 235/2.65	2650
IRB 6700 - 205/2.80	2794
IRB 6700 - 175/3.05	3056
IRB 6700 - 150/3.20	3200
IRB 6700 - 200/2.60	2601
IRB 6700 - 155/2.85	2848
IRB 6700 - 300/2.70	2720
IRB 6700 - 245/3.00	2967

2 Installation and commissioning

2.2.3 Risk of tipping/stability

2.2.3 Risk of tipping/stability

Risk of tipping

Do not change the robot position before securing it to the foundation.
The shipping position is the most stable position.

Shipping and transportation position

This figure shows the robot in its shipping position and transportation position.

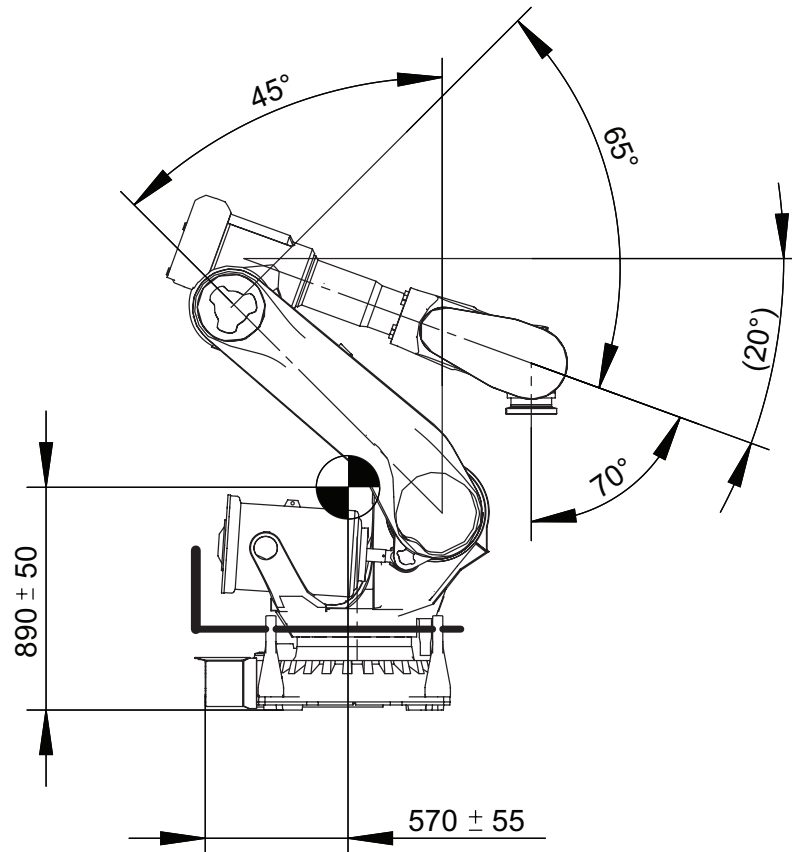

xx1300000356



WARNING

The robot will be mechanically unstable if not properly secured to the foundation.

2.2.4 Main dimensions

Illustration

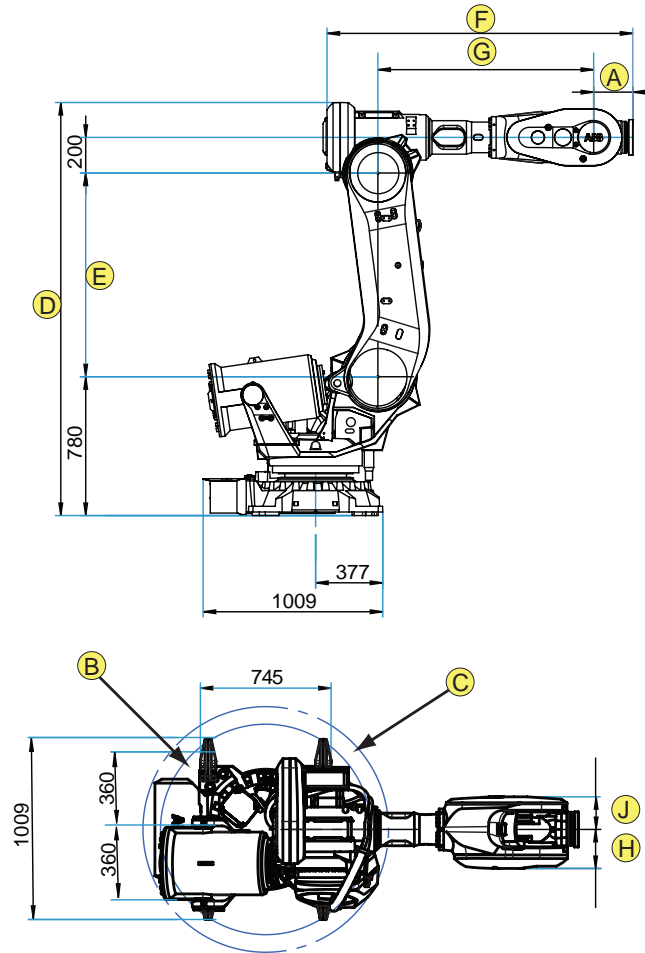

xx130000241

Dimensions for different robot variants

Pos	Description
B	Radius ax1, front = 532 mm (IRB 6700-235/2.65, -205/2.80, -175/3.05, -150/3.20, -200/2.60 and -155/2.85) Radius ax1, front = 532 mm (IRB 6700-235/2.65, -220/2.65 LID, -205/2.80, -200/2.80 LID, -175/3.05, -155/3.05 LID, -150/3.20, -145/3.20 LID, -200/2.60, -175/2.60 LID, -155/2.85 and 140/2.85 LID) Radius ax1, front = 600 mm (IRB 6700-300/2.70 and -245/3.00) Radius ax1, front = 600 mm (IRB 6700-300/2.70, -270/2.70 LID, -245/3.00 and -220/3.00 LID)
C	Radius ax1, back = 633 mm (IRB 6700-235/2.65, -220/2.65 LID, -205/2.80, -200/2.80 LID, -175/3.05, -155/3.05 LID, -150/3.20, -145/3.20 LID, -200/2.60, -175/2.60 LID, -155/2.85 and 140/2.85 LID) Radius ax1, back = 700 mm (IRB 6700-300/2.70, 6700-270/2.70 LID, -245/3.00 and -220/3.00 LID)

Robot variant	A	A LeanID	D	E	F	F LeanID	G	H	J
IRB 6700 - 235/2.65	200	350	2300	1135	1670	1820	1182.5	209	186
IRB 6700 - 205/2.80	200	350	2445	1280	1670	1820	1182.5	186	209

Continues on next page

2 Installation and commissioning

2.2.4 Main dimensions

Continued

Robot variant	A	A LeanID	D	E	F	F LeanID	G	H	J
IRB 6700 - 175/3.05	200	350	2300	1135	2080	2230	1,592.5	209	186
IRB 6700 - 150/3.20	200	350	2445	1280	2080	2230	1592.5	209	186
IRB 6700 - 200/2.60	200	350	2276	1125	1623	1773	1,142.5	197.5	193
IRB 6700 - 155/2.85	200	350	2276	1125	1873	2023	1,392.5	197.5	193
IRB 6700 - 300/2.70	220	380	2321	1145	1718.5	1878.5	1212.5	222.5	187
IRB 6700 - 245/3.00	220	380	2321	1145	1968.5	2128.5	1462.5	222.5	186
IRB 6700 - 220/2.65 LID	200	350	2300	1135	1820	1820	1182.5	209	186
IRB 6700 - 200/2.80 LID	200	350	2445	1280	1820	1820	1182.5	186	209
IRB 6700 - 155/3.05 LID	200	350	2300	1135	2230	2230	1592.5	209	186
IRB 6700 - 145/3.20 LID	200	350	2445	1280	2230	2230	1592.5	209	186
IRB 6700 - 175/2.60 LID	200	350	2276	1125	1773	1773	1142.5	197.5	193
IRB 6700 - 140/2.85 LID	200	350	2276	1125	2023	2023	1392.5	197.5	193
IRB 6700 - 270/2.70 LID	220	380	2321	1145	1878.5	1878.5	1212.5	222.5	187
IRB 6700 - 220/3.00 LID	220	380	2321	1145	2128.5	2128.5	1462.5	222.5	186

2.2.5 The unit is sensitive to ESD

Description

ESD (electrostatic discharge) is the transfer of electrical static charge between two bodies at different potentials, either through direct contact or through an induced electrical field. When handling parts or their containers, personnel not grounded may potentially transfer high static charges. This discharge may destroy sensitive electronics.

Safe handling

Use one of the following alternatives:

- Use a wrist strap.

Wrist straps must be tested frequently to ensure that they are not damaged and are operating correctly.

- Use an ESD protective floor mat.

The mat must be grounded through a current-limiting resistor.

- Use a dissipative table mat.

The mat should provide a controlled discharge of static voltages and must be grounded.

2 Installation and commissioning

2.3.1 Robot transportation precautions

2.3 On-site transportation

2.3.1 Robot transportation precautions

General

This section describes ABB approved transportation precautions for ABB robots.



CAUTION

All transportation in or outside the plant, must be carried out according to the method described in this section.

Transportation in any other way can seriously damage the robot. If the robot is incorrectly transported and the instructions are not followed, the robot is not covered by the warranty and ABB will not accept any compensation claim.

Method 1 - recommended method

Transportation according to method 1 is strongly recommended by ABB.

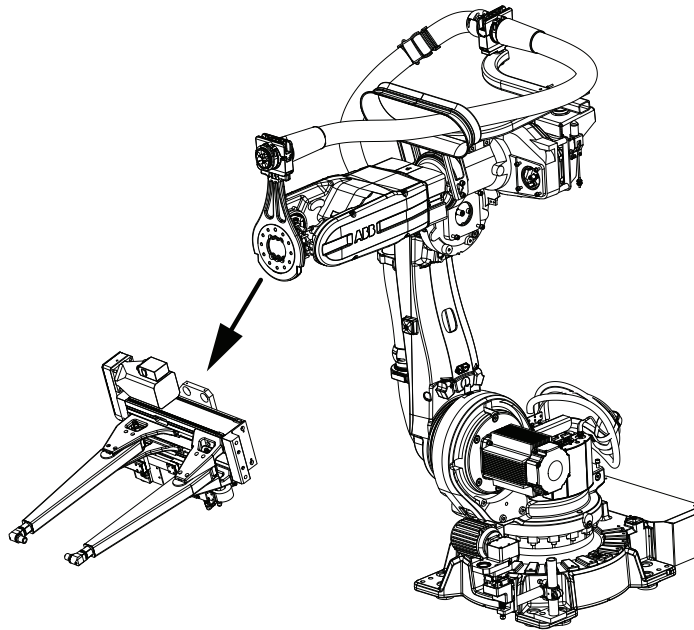

xx080000030

Always follow these instructions when transporting an ABB robot according to method 1:

- Always remove the tool before transportation of the robot.
- Always place the robot in the ABB recommended transport position, described in section [Risk of tipping/stability on page 52](#).
- Always read and follow the instructions in section [Pre-installation procedure on page 42](#)

Continues on next page

Method 2 - transportation with a tool mounted to the robot

Transportation according to method 2 is approved by ABB, only if use of method 1 is not possible.

Always follow these instructions when transporting an ABB robot according to method 2:

- Always read and follow the instructions in section [Securing the robot with a transport support on page 60](#)
- Always place the robot in the ABB recommended transport position for robot with tool, described in sub section [Transport position with a transport support on page 58](#).
- Always use the recommended transport support described in sub section [Recommended transport support on page 59](#).

IRB 6700

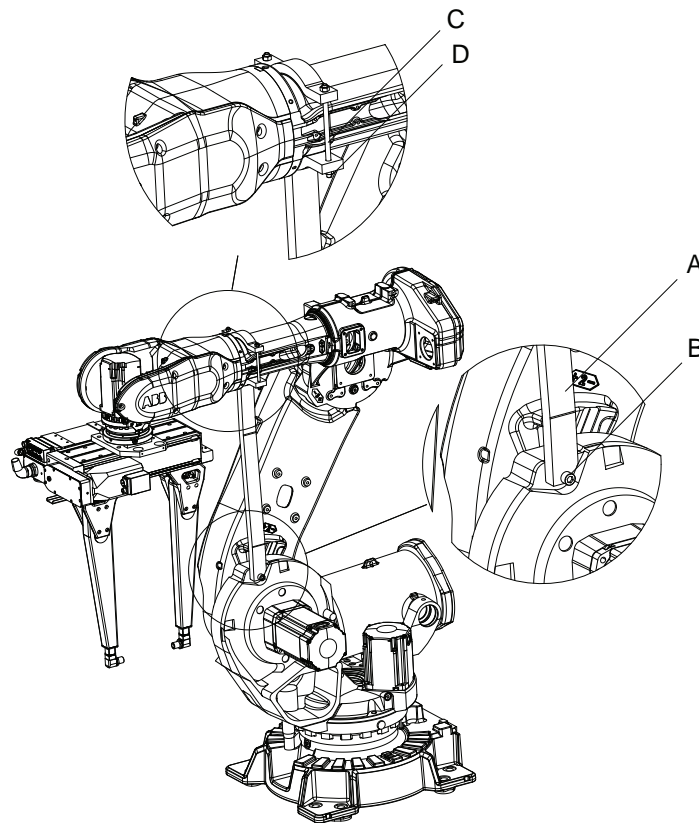

xx0800000037

A	Transport Support
B	Hexagon socket head cap screw M16x140
C	Threaded bar M10x200
D	Nut M10

Continues on next page

2 Installation and commissioning

2.3.1 Robot transportation precautions

Continued

Transport position with a transport support

All transportation of the robot with tool must follow these instructions.

IRB 6700

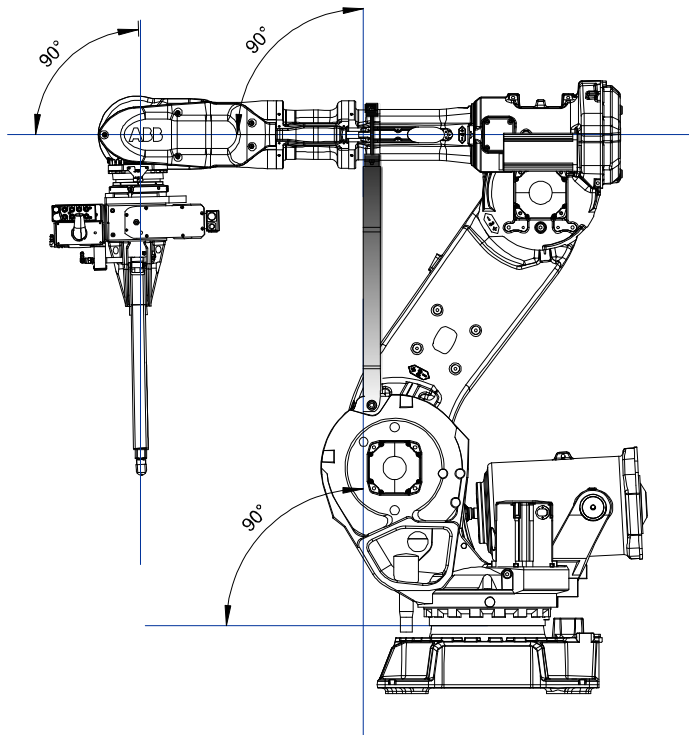

xx080000040

Continues on next page

Recommended transport support

Always use the recommended transport support when transporting a robot with tool.

IRB 6700

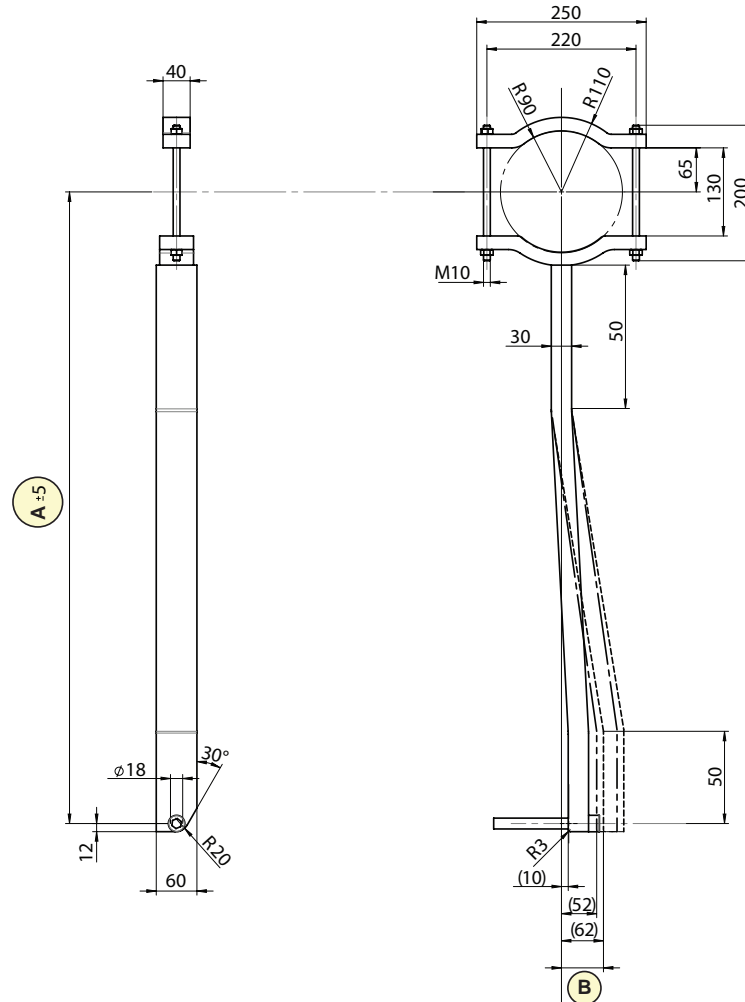

xx1300001603

Variant	IRB 6700 - 235/2.65	IRB 6700 - 205/2.80	IRB 6700 - 175/3.05	IRB 6700 - 150/3.20	IRB 6700 - 200/2.60	IRB 6700 - 155/2.85	IRB 6700 - 300/2.70	IRB 6700 - 245/3.00
Lower arm L	1135	1280	1135	1280	1125	1125	1145	1145
A	1000	1160	630	860	1004	817	1000	817
B	21	21	21	21	21	21	6	6

2 Installation and commissioning

2.3.2 Securing the robot with a transport support

2.3.2 Securing the robot with a transport support

General

This section describes how to fit the transport support to the robot in order to secure the robot for transportation. The transport support is required if the robot must be transported with mounted tools.



DANGER

Releasing the brakes is a hazardous action that may cause injury and damage property. It must be done with great care and only when absolutely necessary.

Fitting the transport support

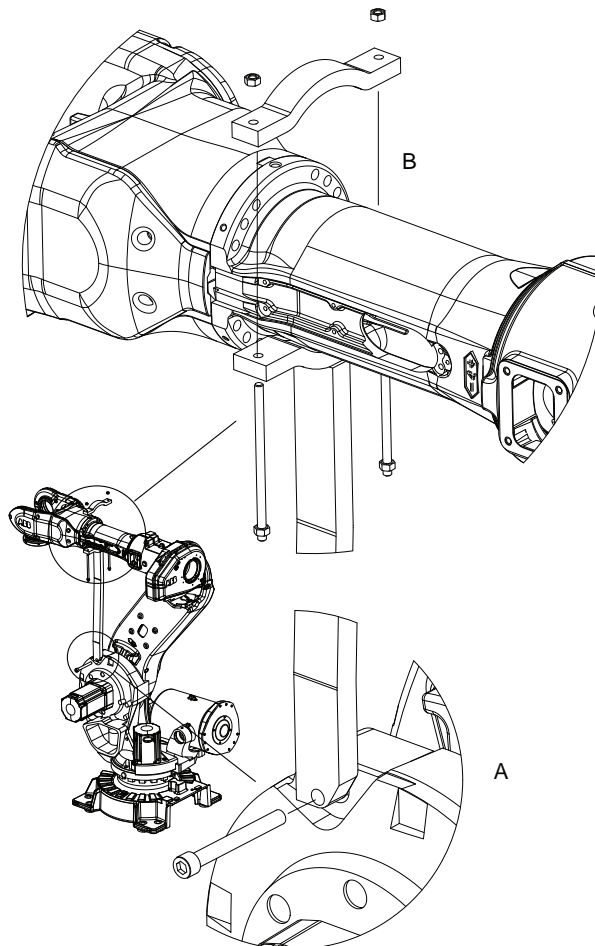

Illustration for fitting the transport support



xx080000062

Continues on next page

Fitting the transport support

	Action	Note
1	Fit the transport support's lower end to the robot using the recommended screw joint, (A) in figure.	Do not tighten the screw. See attachment point for the specific robot in the section Transport position with a transport support on page 58 .
2	Jog the robot into a position as near above as possible to the recommended transport position for the specific robot, as specified in section Transport position with a transport support on page 58 .	 CAUTION Do not try to jog the robot to the exact position (max distance 1mm).
3	Use the brake release for axis 3 to reach the final resting position on the transport support, see the section Manually releasing the brakes on page 78 .	See attachment point for the specific robot in the section Transport position with a transport support on page 58
4	Tighten all the attachment screws, (A) and (B), in the figure with the brake release for axis 3 still activated starting with the lower attachment screw.	 CAUTION Do not attempt to tighten any attachment screws without first releasing the brakes. This can seriously damage the robot.
5	Use the brake release for axis 5 and 6 to reach the final resting position for the tool, see the section Manually releasing the brakes on page 78	

2 Installation and commissioning

2.4.1 Brief installation procedure

2.4 On-site installation

2.4.1 Brief installation procedure

Introduction

This procedure is a brief guide when installing the robot for the first time. Also see [Pre-installation procedure on page 42](#).

First installation

Use these procedures to install the IRB 6700.

	Action	Note
1	Transport the manipulator to its intended location.	
2	Install the valid platform or prepare the foundation for the manipulator.	See Securing the base plate on page 64 .
3	Lift and secure the manipulator to the platform/foundation.	See Lifting the robot on page 66 . See Orienting and securing the robot on page 73 .
4	Connect the manipulator to the controller.	See <ul style="list-style-type: none">• Product manual - IRC5• Product manual - IRC5 Panel Mounted Controller• Product manual - OmniCore V250XT
5	Configure the safety settings.	See <ul style="list-style-type: none">• Product manual - IRC5• Product manual - IRC5 Panel Mounted Controller• Product manual - OmniCore V250XT
6	How to start and run the robot is described in the product manual for the controller.	See <ul style="list-style-type: none">• Product manual - IRC5• Product manual - IRC5 Panel Mounted Controller• Product manual - OmniCore V250XT
7	Install required equipment, if any. <ul style="list-style-type: none">• Signal lamp (option) on page 94	
8	 DANGER Make sure all safety requirements are met when performing the first test run.	

2.4.2 Lifting the base plate

Required equipment

Equipment	Article number	Note
Lifting eye, M16	3HAC14457-4	3 pcs
Lifting slings		Length: approx. 2 m

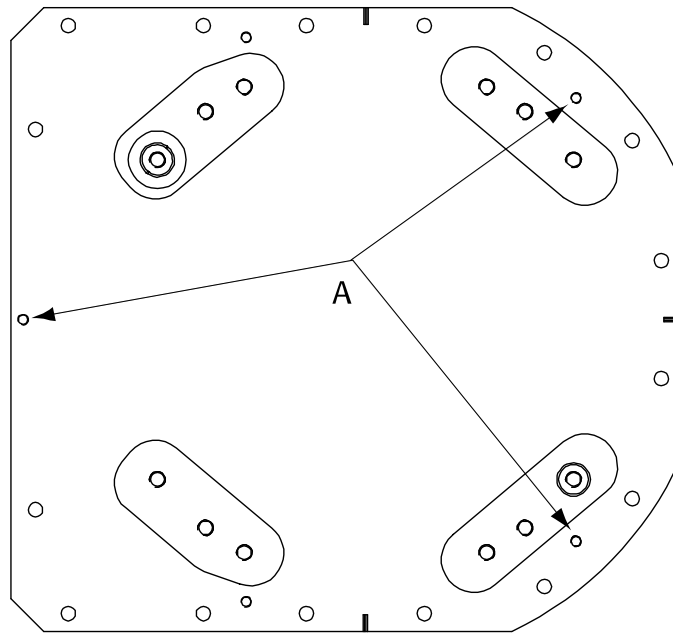

Hole configuration



xx020000096

A	Attachment holes for lifting eyes (x3)
---	--

Lifting, base plate

	Action	Note
1	 CAUTION The base plate weighs 353 kg. All lifting accessories used must be sized accordingly.	
2	Fit lifting eyes in specified holes.	Shown in figure Hole configuration on page 63 .
3	Fit lifting slings to the eyes and to the lifting accessory.  CAUTION Lift and move the base plate very slowly. If the base plate starts to swing it is a risk for injuries or damage.	

2 Installation and commissioning

2.4.3 Securing the base plate

2.4.3 Securing the base plate

Base plate, orienting grooves and leveling bolts

The illustration below shows the orienting grooves and attachment holes for leveling bolts in the base plate.

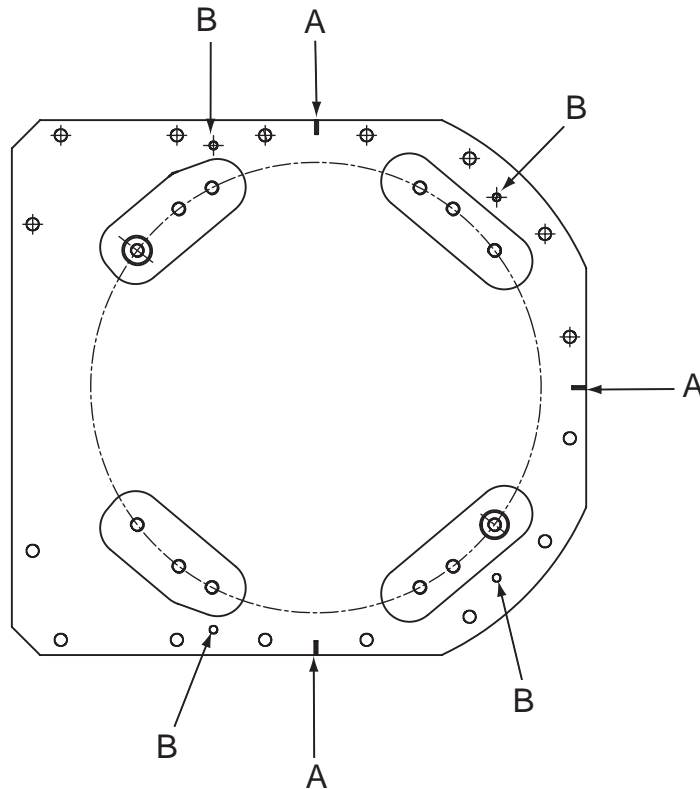

xx1500000312

A	Orienting grooves (3 pcs)
B	Levelling bolts, attachment holes (4 pcs)



Required equipment

Equipment	Article number	Note
Base plate	3HAC051821-001	Includes <ul style="list-style-type: none"> guide pins levelling screws, 9ADA120-79 attachment screws and washers for securing the robot to the base plate.
Standard toolkit	-	Content is defined in section Standard toolkit on page 814 .
Other tools and procedures may be required. See references to these procedures in the step-by-step instructions below.		These procedures include references to the tools required.

Continues on next page

Base plate

This section details how to secure the base plate to the foundation.

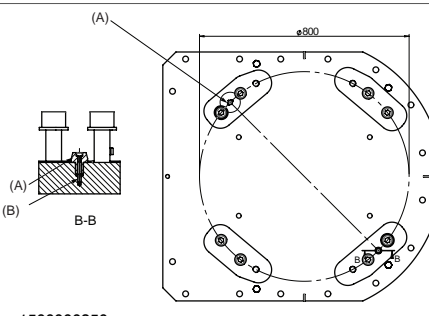
	Action	Note
1	Make sure the foundation is levelled.	
2	 CAUTION The base plate weighs 353 kg! All lifting equipment used must be sized accordingly!	
3	Position base plate in relation to the robot work location using the grooves in the base plate.	Shown in figure Base plate, orienting grooves and leveling bolts on page 64 .
4	Lift the base plate to its mounting position.	Detailed in section Lifting the base plate on page 63 .
5	Use the base plate as a template and drill attachment holes as required by the selected bolt dimension.	Attachment holes: 16 pcs.
6	Fit the base plate and use the levelling bolts to level the base plate.	Shown in figure Base plate, orienting grooves and leveling bolts on page 64 .
7	If required, fit strips of sheet metal underneath the base plate to fill any gaps.	
8	Secure the base plate to the foundation with screws and sleeves.	
9	Recheck the four contact surfaces on the base plate to make sure the base plate is levelled and flat. If it is not, use pieces of sheet metal or similar to bring the base plate to a levelled position.	Maximum allowed deviation all over the base plate, from one contact surface to the other: 0.3 mm.
10	 Note All screws and pins are delivered in a plastic bag together with the base plate.	 <p>xx1500000250</p> <p>A Cylindrical guide pin B M5 x 40. Tightening torque 6 Nm. (x2)</p>

2 Installation and commissioning

2.4.4.1 Lifting the robot with fork lift

2.4.4 Lifting the robot

2.4.4.1 Lifting the robot with fork lift

Lifting methods

The robot may be lifted and transported using a fork lift, provided that available special aids are used.

This section specifies available special aids and references to valid user documentation for the lifting accessories.

Required tools and equipment

Equipment	Article number	Note
Fork lift accessory set	3HAC047054-003	Contains fork lift pockets and all required hardware for installation. User instructions are enclosed with the tool, see Directions for use - Fork lift accessory for IRB 6700.

Required documents

Document	Document number
Directions for use - Fork lift accessory for IRB 6700	3HAC048484-002

Lifting the robot

	Action	Note
1	Lift the robot according to the user instructions enclosed with the fork lift accessory.	

2.4.4.2 Lifting robot with lifting accessory

General

This section contains a general overview of how to lift the complete robot using special lifting accessory.

Illustration, lifting accessory

The following figure shows the principle for how to use and lift the entire robot with lifting accessory. For a more detailed instruction, see the user instructions enclosed with the accessory.



Note

The user manual may be out of date. The latest revision is available for download via myABB Business Portal, www.abb.com/myABB.

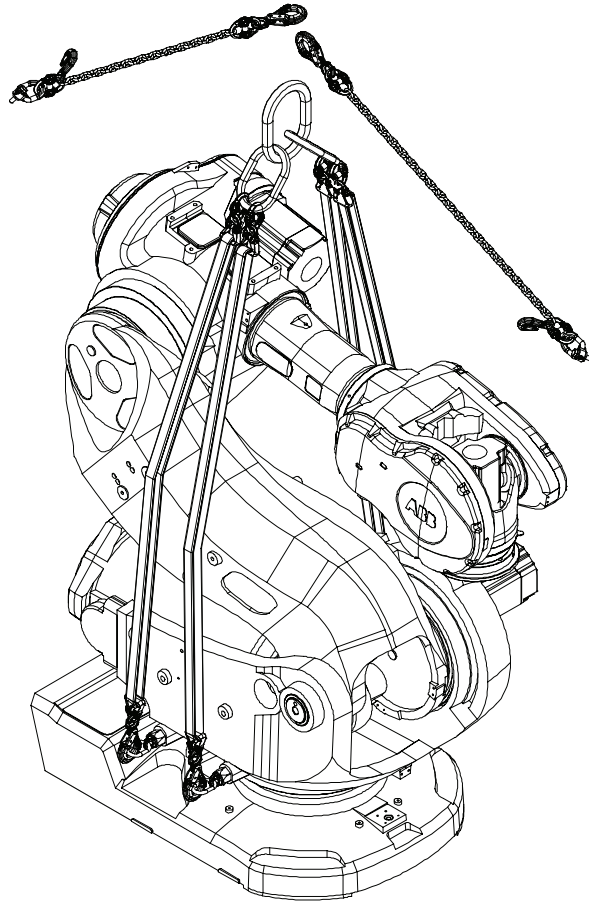

xx0200000153

Required equipment

Equipment	Article number	Note
Lifting accessory, robot	3HAC15607-1	Includes user instructions 3HAC15971-2

Continues on next page

2 Installation and commissioning

2.4.4.2 Lifting robot with lifting accessory

Continued



Slings attached directly onto robot

This section details how to lift and move the robot using lifting slings when these are attached directly onto the robot frame.



Note

Please refer to the enclosed user instruction for instruction how to place the manipulator in an correct position. Attempting to lift a manipulator in any other position may result in the robot tipping over, causing severe damage or injury!

	Action	Note
1	Run the overhead crane to a position above the robot.	
2	Position the robot as detailed in enclosed instruction!	Article number is specified in Required equipment on page 67 . Release the brakes, if required, as detailed in section Manually releasing the brakes on page 78 .
3	Fit the <i>lifting accessory</i> to the robot as described in the enclosed instruction!	Article number is specified in Required equipment on page 67 .
4	 CAUTION The IRB 6700 robot weighs 1300 kg. All lifting accessories used must be sized accordingly!	
5	 WARNING Personnel must not, under any circumstances, be present under the suspended load!	
6	Raise overhead crane to lift the robot.	Make sure all hooks and attachments maintain their correct positions while lifting the robot! Always move the robot at very low speeds, making sure it does not tip.

2.4.4.3 Lifting the robot with roundslings

Roundslings used for lifting and transporting

The robot can be lifted and transported using roundslings according to this section.

Attaching the roundslings

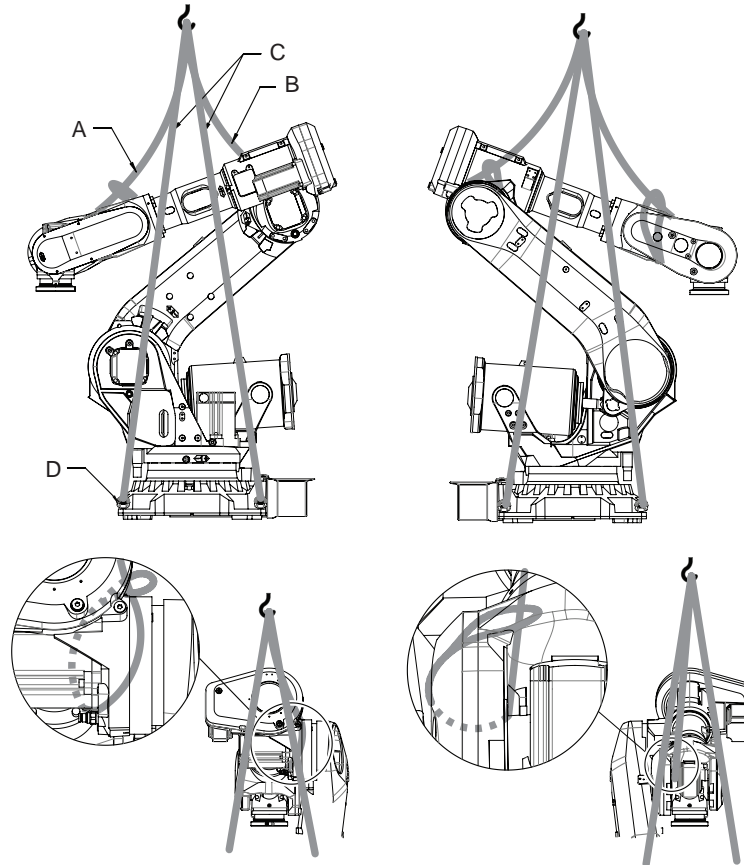

Variant	Length A (1 pc) Do not strain!	Length B (1 pc) Do not strain!
IRB 6700 - 235/2.65	Roundsling, 2 m	Roundsling, 2 m
IRB 6700 - 205/2.80	Roundsling, 2 m	Roundsling, 2 m
IRB 6700 - 175/3.05	Roundsling, 2.5 m	Roundsling, 2 m
IRB 6700 - 150/3.20	Roundsling, 2.5 m	Roundsling, 2 m
IRB 6700 - 200/2.60	Roundsling, 2 m	Roundsling, 2 m
IRB 6700 - 155/2.85	Roundsling, 2.5 m	Roundsling, 2 m
IRB 6700 - 300/2.70	Roundsling, 2 m	Roundsling, 2.5 m
IRB 6700 - 245/3.00	Roundsling, 2.5 m	Roundsling, 2.5 m
C	Roundsling, 2.5 m (4 pcs)	
D	Lifting eye, M20 (4 pcs)	

Continues on next page

2 Installation and commissioning

2.4.4.3 Lifting the robot with roundslings

Continued

Required equipment

See quantity of roundslings in figure [Attaching the roundslings on page 69](#).

Equipment, etc.	Article number	Note
Overhead crane	-	
Lifting eye, M20	-	Working load limit: 2,000 kg.
Roundslings, 2 m	-	Length: 2 m. Lifting capacity: 2,000 kg.
Roundslings, 2.5 m	-	Length: 2.5 m. Lifting capacity: 2,000 kg.

Lifting the robot with roundslings

Use this procedure to lift the robot with roundslings.

Jogging the robot to lifting position

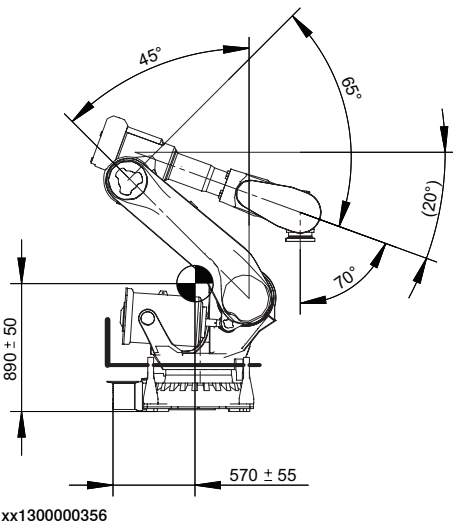
Action	Note
<p>1 Jog the robot into position:</p> <ul style="list-style-type: none"> • Axis 1: calibration position (0°) • Axis 2: -45° • Axis 3: +65° • Axis 4: no significance • Axis 5: +70° • Axis 6: no significance <p> WARNING</p> <p>The robot is likely to be mechanically unstable if not secured to the foundation.</p>	 <p>xx1300000356</p>



Continues on next page

2 Installation and commissioning

2.4.4.3 Lifting the robot with roundslings

Continued

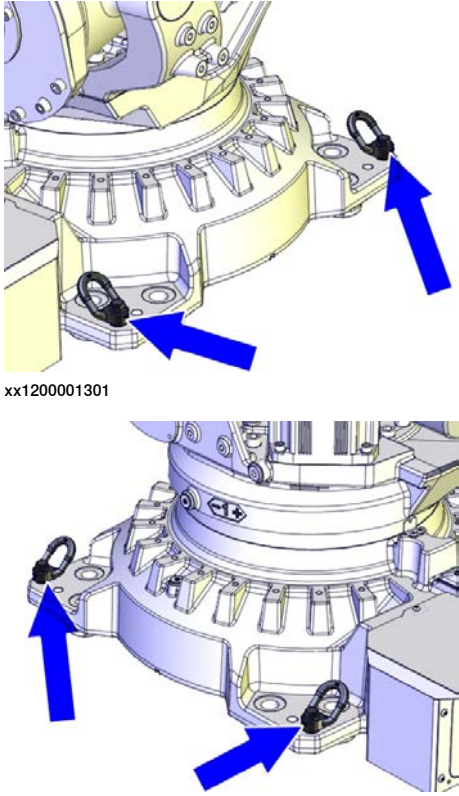
Lifting the robot with roundslings

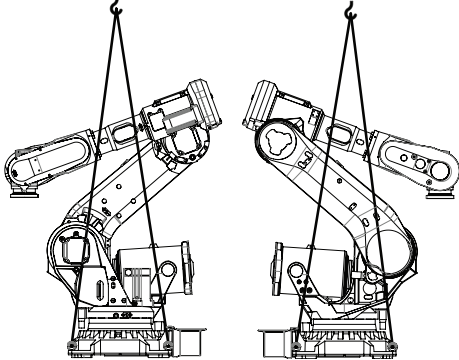





	Action	Note
1	<p>Fit lifting eyes to the outer holes on each corner of the base.</p>	 <p>xx1200001301</p> <p>xx1200001302</p>
2	<p>Run roundslings through the lifting eyes and fasten them in an overhead crane.</p> <p> CAUTION</p> <p>If the lifting eyes have sharp edges that might damage the roundslings, lifting shackles must be used to attach the roundslings to the lifting eyes.</p>	<p>Make sure the roundslings do not rub against any sharp edges.</p> <p>Roundslings, 2.5 m (4 pcs)</p>  <p>xx1300001572</p>

Continues on next page

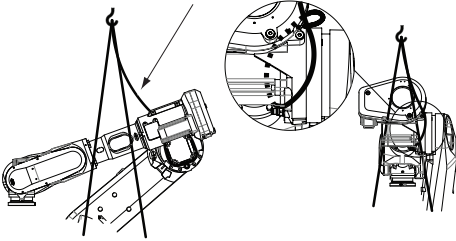
2 Installation and commissioning

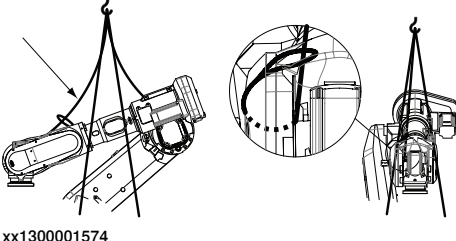
2.4.4.3 Lifting the robot with roundslings

Continued

	Action	Note
3	<p>Attach a securing roundsling at the rear according to figure.</p> <p> Note</p> <p>The securing sling must not be strained at lifting. It only secures for tipping.</p>	<p>Length for the roundsling is given in the table Attaching the roundslings on page 69.</p>  <p>xx1300001573</p>
4	<p>Attach a securing roundsling at the front according to figure.</p> <p> Note</p> <p>The securing sling must not be strained at lifting. It only secures for tipping.</p>	<p>Length for the roundsling is given in the table Attaching the roundslings on page 69.</p>  <p>xx1300001574</p>
5	<p> CAUTION</p> <p>The IRB 6700 robot weighs 1300 kg. All lifting accessories used must be sized accordingly!</p>	
6	<p> WARNING</p> <p>Personnel must not, under any circumstances, be present under the suspended load!</p>	
7	<p>Raise the overhead crane to lift the robot.</p> <p> CAUTION</p> <p>Make sure that the roundsling running from the front, left corner is positioned on the correct side of the brake release unit plate when stretching the roundslings with the crane.</p>	

2.4.5 Orienting and securing the robot

General

This section details how to orient and secure the robot to the base plate in order to run the robot safely.

It also contains information about securing the robot to a track motion.

Hole configuration, base

The figure shows the hole configuration used when positioning and securing the robot.

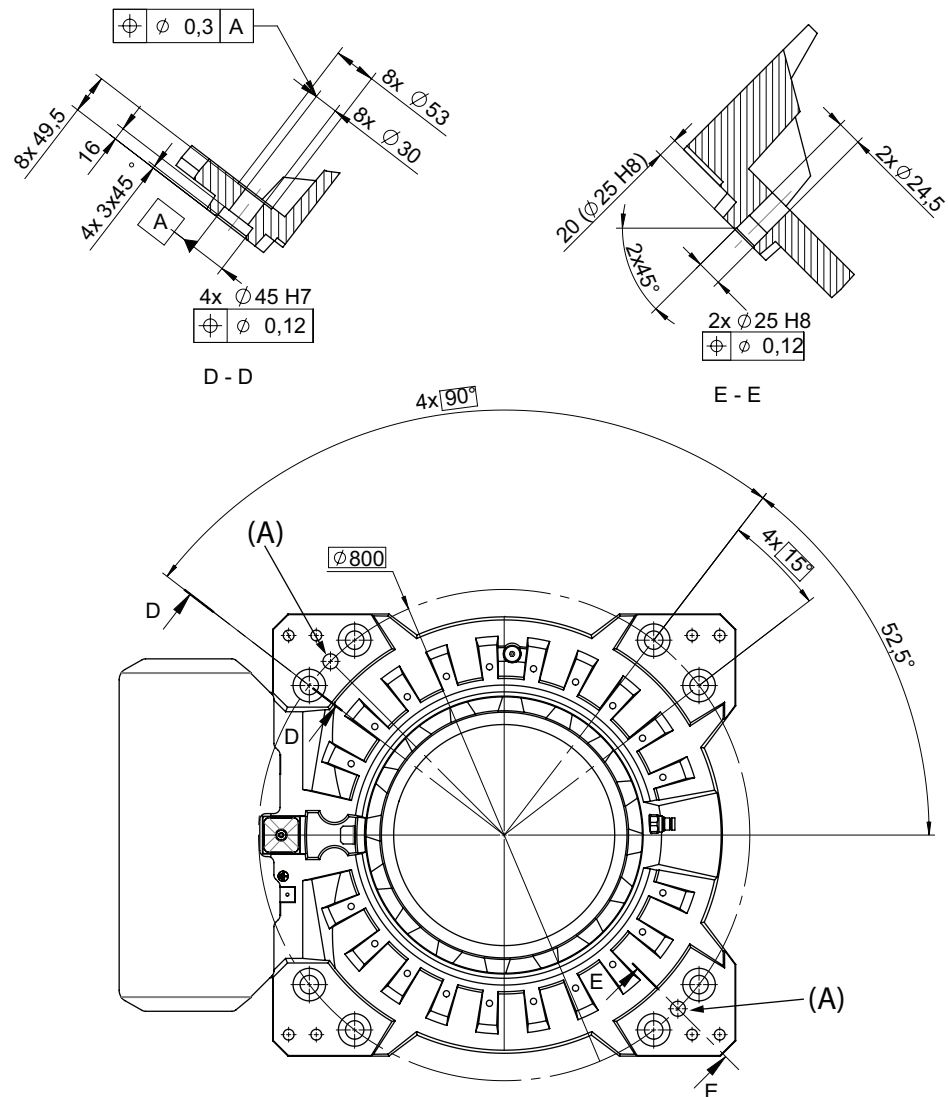

xx1300000243

Pos	Description
A	Holes for guide pins (x2)

Continues on next page

2 Installation and commissioning

2.4.5 Orienting and securing the robot

Continued

Required equipment

It is necessary to use guide pins when securing the robot to a base plate or a track motion.

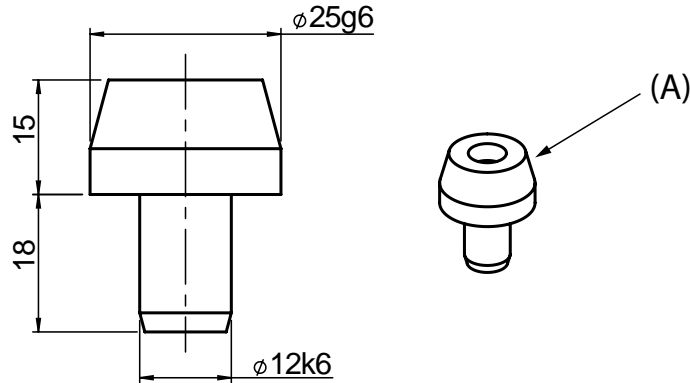

XX1500000248

A	Cylindrical guide pin
---	-----------------------

Attachment screws

The table below specifies the type of securing screws and washers to be used for securing the robot to the base plate/foundation or to a track motion IRBT 6004/7004.

Suitable screws, lightly lubricated:	M24 x 100 (installation on base plate/foundation)
Quantity:	8 pcs
Quality:	8.8
Screw tightening yield point utilization factor (v) (according to VDI2230):	90% (v=0.9)
Suitable washer:	4 mm flat washer
Tightening torque:	550 Nm (screws lubricated with Molykote 1000) 600-725 Nm, typical 650 Nm (screws none or lightly lubricated)



Continues on next page

Securing the robot to the base plate/foundation

Use this procedure to secure robot to base plate after fitting plate to the foundation.

The same procedure is also used to secure the robot to a track motion carriage.

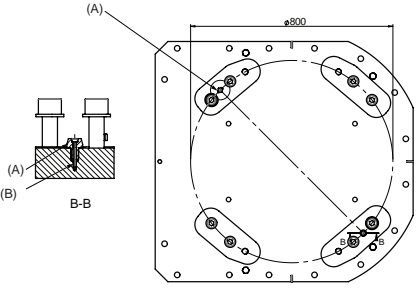
See specific pictures for this in figure [Securing the robot to a track motion on page 76](#).

	Action	Note
1	<p>Fit two guide pins to the guide pin holes in the base plate.</p> <p> Note</p> <p>All screws and pins are delivered in a plastic bag together with the base plate.</p>	 <p>xx150000250</p> <p>A Cylindrical guide pin (2 pcs) B M5 x 40. Tightening torque 6 Nm. (x2)</p>
2	Lift the robot.	See Lifting the robot with roundslings on page 69 .
3	Move robot close to its installation location.	
4	Guide the robot gently using two M24 screws while lowering it into its mounting position.	Make sure the robot base is correctly fitted onto the guide sleeves!
5	Fit the bolts and washers in the base attachment holes.	<p>Specified in Attachment screws on page 74.</p> <p> Note</p> <p>Lightly lubricate screws before assembly.</p>
6	Tighten bolts in a crosswise pattern to ensure that the base is not distorted.	

Continues on next page

2 Installation and commissioning

2.4.5 Orienting and securing the robot

Continued

Securing the robot to a track motion

Fitting manipulator to a standard carriage

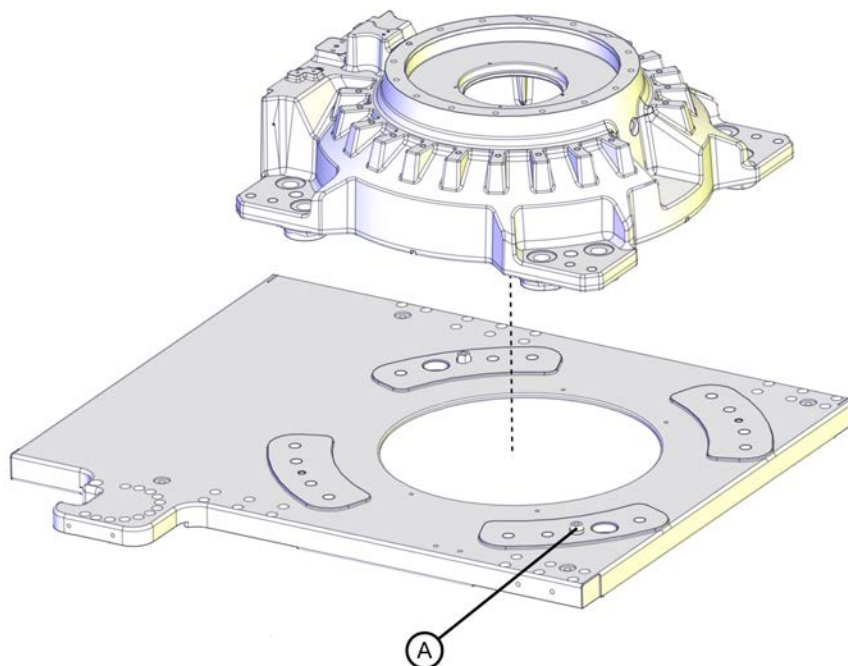

xx150000319

Pos	Description
A	Cylindrical guide pin



Note

There are versions with a flattened cylindrical guide pin in left rear of the base.

Continues on next page

Fitting manipulator to a carriage plate

The figure below shows the carriage plate that is used as a second added carriage for a double track or as a single carriage as mirrored, for track motions IRBT 6004/7004.

There are adapters fitted to the guide pin holes in each corner of the plate, to allow the robot to be installed in-line, turned 90° or 180°.

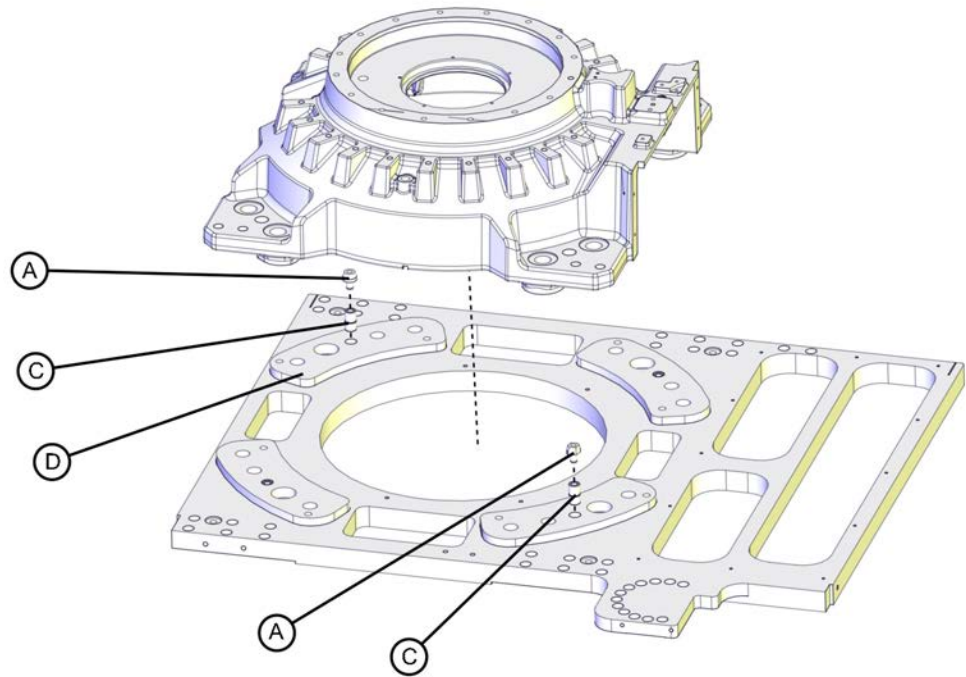

xx150000320

Pos	Description
A	Cylindrical guide pin.
C	Adapter for guide pin (fitted to the carriage at delivery)
D	Distance plate (fitted to the carriage at delivery)



Note

There are versions with a flattened cylindrical guide pin in left rear of the base. It is important that the flattened pin is aligned in correct direction.

2 Installation and commissioning

2.4.6 Manually releasing the brakes

2.4.6 Manually releasing the brakes

Introduction to manually releasing the brakes

This section describes how to release the holding brakes for the motors of each axis.

Location of brake release unit

The internal brake release unit is located as shown in the figure.

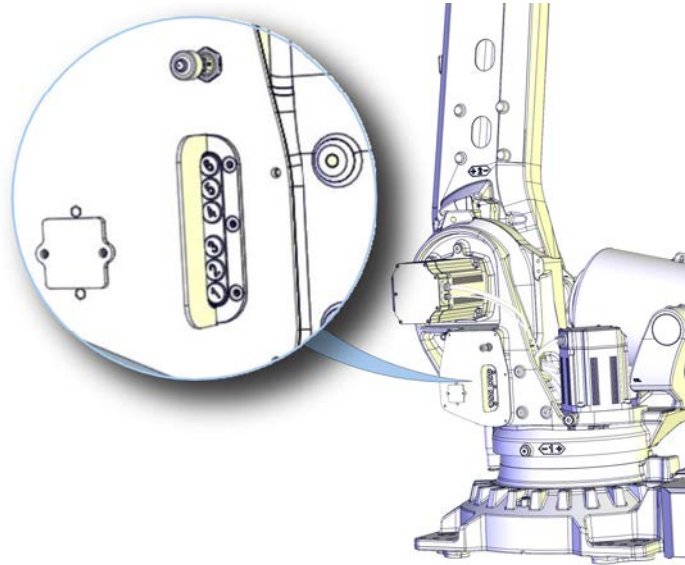

xx120000964

Releasing the brakes

This procedure details how to release the holding brakes when the robot is equipped with an internal brake release unit.

	Action	Note
1	<p>The internal brake release unit is equipped with buttons for controlling the axes brakes. The buttons are numbered according to the numbers of the axes.</p> <p>If the robot is not connected to the controller, power must be supplied to the connector R1.MP according to the section Supplying power to connector R1.MP on page 79.</p>	<p>Buttons are shown in figure Location of brake release unit on page 78.</p>
2	<p> DANGER</p> <p>When releasing the holding brakes, the robot axes may move very quickly and sometimes in unexpected ways.</p> <p>Make sure no personnel is near or beneath the robot.</p>	

Continues on next page

2 Installation and commissioning

2.4.6 Manually releasing the brakes

Continued

	Action	Note
3	Release the holding brake on a particular robot axis by pressing the corresponding button on the internal brake release unit. The brake will function again as soon as the button is released.	

Supplying power to connector R1.MP

If the robot is not connected to the controller, power must be supplied to connector R1.MP on the robot, in order to enable the brake release buttons.

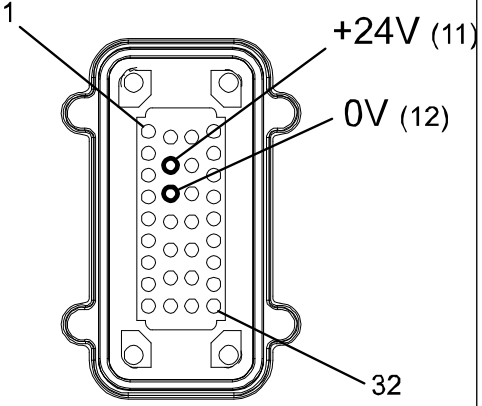
	Action	Note
1	 DANGER Incorrect connections, such as supplying power to the wrong pin, may cause all brakes to be released simultaneously!	
2	Supply 0V on pin 12 and 24V on pin 11.	 xx0600002937

2 Installation and commissioning

2.4.7 Loads fitted to the robot, stopping time and braking distances

2.4.7 Loads fitted to the robot, stopping time and braking distances

General

Any loads mounted on the robot must be defined correctly and carefully (with regard to the position of center of gravity and mass moments of inertia) in order to avoid jolting movements and overloading motors, gears and structure.



CAUTION

Incorrectly defined loads may result in operational stops or major damage to the robot.

References

Load diagrams, permitted extra loads (equipment) and their positions are specified in the product specification. The loads must be defined in the software.

- *Operating manual - IRC5 with FlexPendant*

Stopping time and braking distances

The performance of the motor brake depends on if there are any loads attached to the robot. For more information, see product specification for the robot.

2.4.8 Fitting equipment to the robot

General

Extra loads can be fitted on the upper arm housing, the lower arm, and on the frame. Definitions of distances and masses are shown in the following figures. The robot is supplied with holes for fitting extra equipment (see figure in [Holes for fitting extra equipment on page 83](#)). Maximum allowed arm load depends on center of gravity of arm load and robot payload.



Note

All equipment and cables used on the robot, must be designed and fitted not to damage the robot and/or its parts.

Frame (hip load)

Extra load can be fitted on the frame.

	Description
Permitted extra load on frame	$J_H = 100 \text{ kgm}^2$
Recommended position (see the following figure)	$J_H = J_{H0} + M4 \times R^2$ where: <ul style="list-style-type: none"> • J_{H0} is the moment of inertia of the equipment • R is the radius (m) from the center of axis 1 • $M4$ is the total mass (kg) of the equipment including bracket and harness ($\leq 250 \text{ kg}$)

Continues on next page

2 Installation and commissioning

2.4.8 Fitting equipment to the robot

Continued

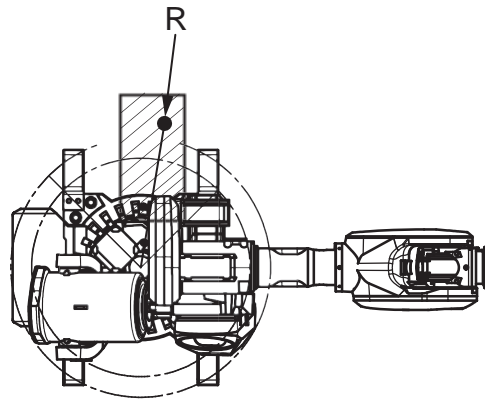
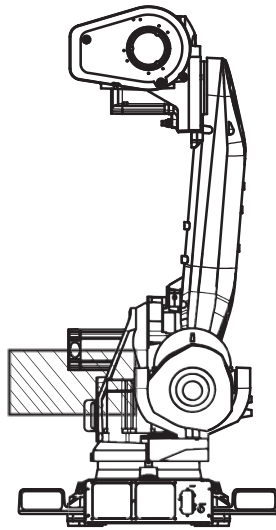

xx130000262

Upper arm

Allowed extra load on the upper arm housing, in addition to the maximum handling weight, is $M1 \leq 50$ kg with a distance (a) ≤ 500 mm from the center of gravity in the axis-3 extension.

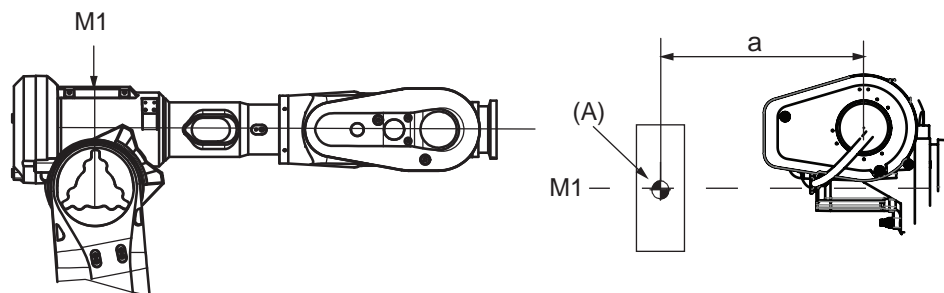

xx1400002019

A	Mass center
---	-------------

Continues on next page

2 Installation and commissioning

2.4.8 Fitting equipment to the robot

Continued

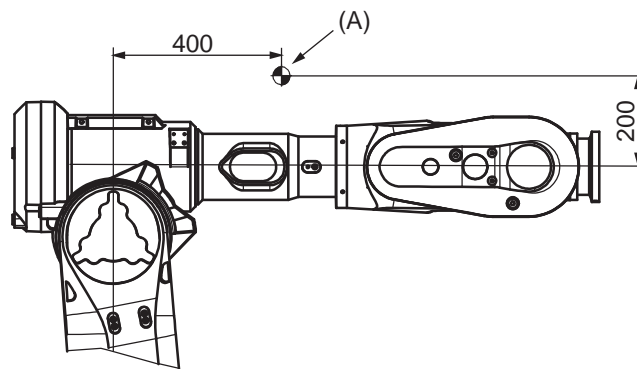

xx130000866

A	Center of gravity 50 kg
---	-------------------------

Holes for fitting extra equipment

Continues on next page

2 Installation and commissioning

2.4.8 Fitting equipment to the robot

Continued

Tool flange, standard

Below is the standard tool flange. The guide pin hole is, in calibration position, pointing upwards in Z-direction.

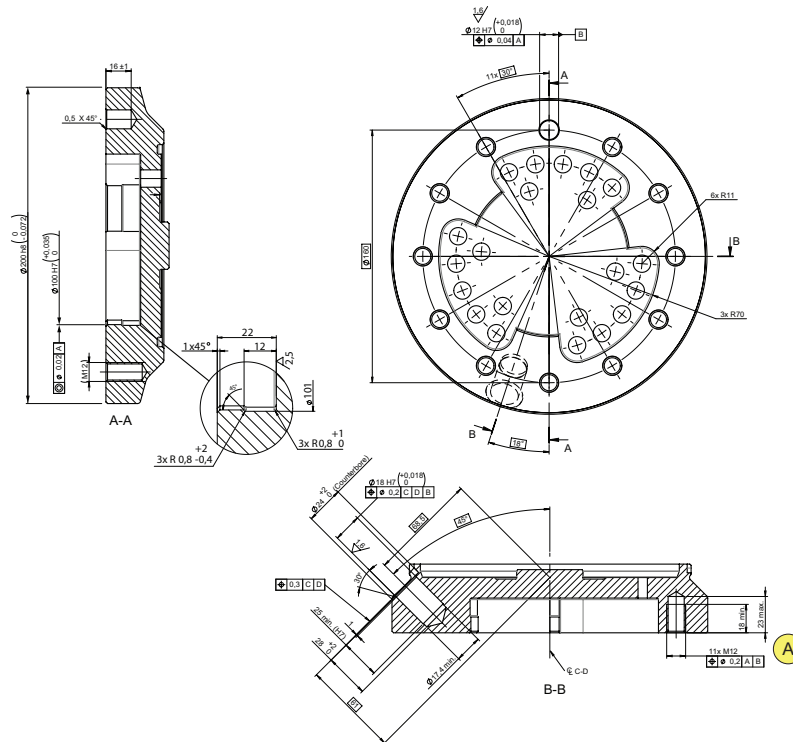

xx1300000280

A	Thread length: 18 mm.
---	-----------------------

The turning disc for robot variants IRB 6700 - 200/2.60 and IRB 6700 - 155/2.85 was redesigned when Axis Calibration was introduced for IRB 6700. Prior to Axis Calibration the holes on the disc were through. On the current turning disc the holes are not through.

Continues on next page

Tool flange, LeanIDLID Variants

Below is the tool flange for option 780-4, LeanIDLID variants. The guide pin hole is, in calibration position, pointing upwards in Z-direction.

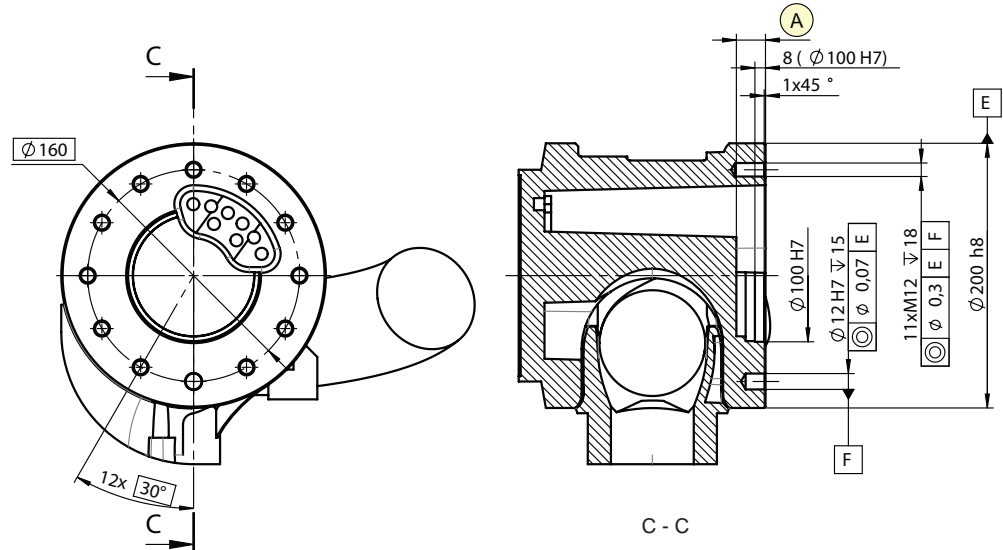

xx1300000290

A	Thread length: 18 mm.
---	-----------------------

Fastener quality

When fitting tools on the tool flange, only use screws with quality 12.9. For other equipment use suitable screws and tightening torque for your application.

2 Installation and commissioning

2.4.9 Extended working range, axis 1 (option)

2.4.9 Extended working range, axis 1 (option)

Overview

The working range of axis 1 can be extended on a floor-mounted robot, from the default range limited by mechanical stops. The working range can be extended to $\pm 220^\circ$.



CAUTION

The option *Extended work range* enables an extension of the working range for axis 1, through a software configuration. With this option installed, the working range can exceed the range limited by the mechanical stop on axis 1. The working range shall be limited through the option *SafeMove*.

A risk analysis must be done to ensure that no risks remain when using option *Extended work range*, to limit the working range, and before removing the mechanical stops.

For information about the option *SafeMove*, see *Application manual - Functional safety and SafeMove*.

If the mechanical stop is removed, then the manipulator should have a marking for this, for example, a label. If the robot is delivered with the option *Extended work range*, then such a label is included on delivery.

Extending the working range

	Action	Note/Illustration
1	Configure the safety setup and verify it by test.	
2	Hold the mechanical stop pin in a firm grip, and remove it by unscrewing the attachment screw.	 xx2100001705 A Mechanical stop pin
3	In RobotWare, redefine the working range limitations in the system parameters, topic <i>Motion</i> . The <i>Arm</i> parameters <i>Upper Joint Bound</i> and <i>Lower Joint Bound</i> can be changed to the values corresponding to the actual installation.	With the option <i>Extended working range</i> , the maximum value for the system parameters <i>Upper Joint Bound</i> and <i>Lower Joint Bound</i> is 3.84 respectively -3.84. The values are in radians, that is 3.84 radians = 220 degrees.

Related information

The system parameters are described in detail in the reference manual, see [References on page 10](#).

For more information about *SafeMove*, see *Application manual - Functional safety and SafeMove2 (IRC5)* or *Application manual - Functional safety and SafeMove (MC)*.

2.5 Restricting the working range

2.5.1 Axes with restricted working range

General

When installing the robot, make sure that it can move freely within its entire working space. If there is a risk that it may collide with other objects, its working space should be limited.

The working range of the following axes may be restricted:

- Axis 1, hardware (mechanical stop) and software.
- Axis 2, software.
- Axis 3, software.

This section describes how to install hardware that restricts the working range.



Note

Adjustments must also be made in the robot configuration software (system parameters). References to relevant manuals are included in the installation procedures.

2 Installation and commissioning

2.5.2 Mechanically restricting the working range of axis 1

2.5.2 Mechanically restricting the working range of axis 1

General

The working range of axis 1 is limited by fixed mechanical stops and adjustment of the system parameter configuration. The working range can be reduced by adding additional mechanical stops giving 15° graduation, between $\pm 5^\circ$ and $\pm 125^\circ$ in both directions.

Mechanical stops, axis 1

The illustration shows the mounting position of the stop pin and one of the additional mechanical stops available for axis 1.

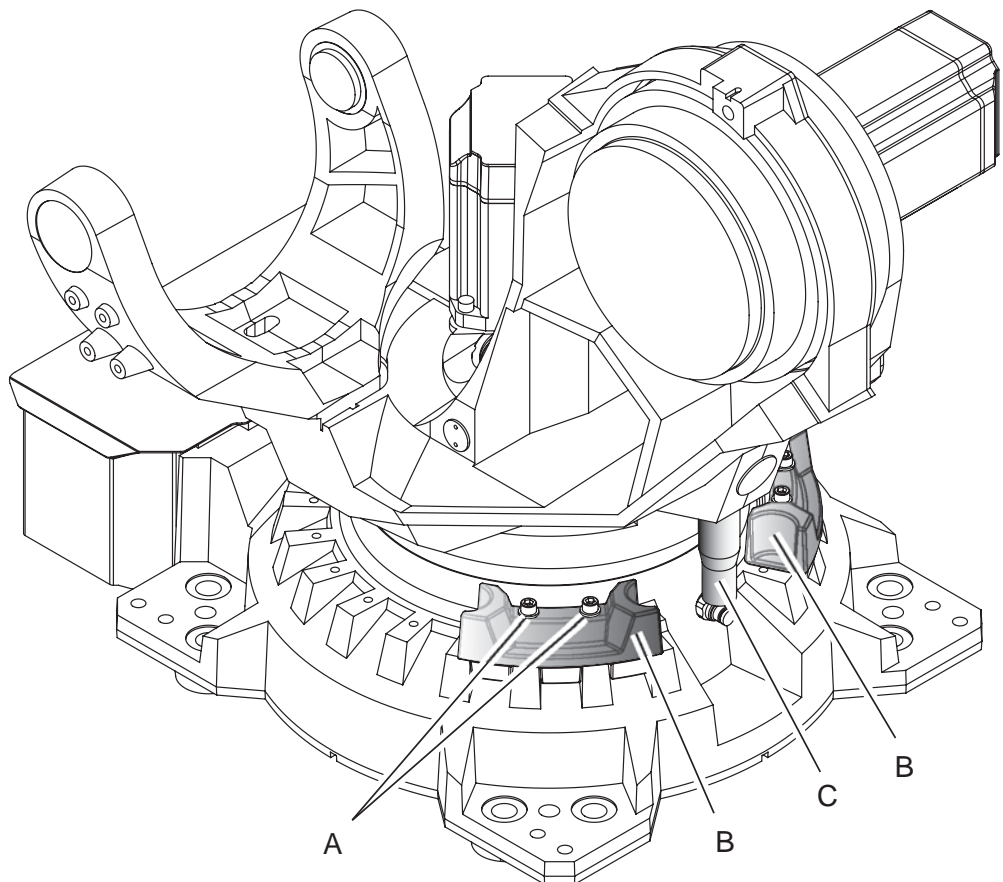

xx1300001971

A	Attachment screws M12x70 quality 12.9 Gleitmo 603 (2 pcs per additional mechanical stop)
B	Movable mechanical stop
C	Mechanical stop pin axis-1



Continues on next page

Required equipment

Equipment, etc.	Article number	Note
Movable mechanical stop set, axis 1 (15°).	3HAC055744-001	IRB6700 235/2.65, 205/2.80, 175/3.05, 150/3.20, 200/2.60, 155/2.85 Includes attachment screws and an assembly drawing.
Movable mechanical stop set, axis 1 (15°).	3HAC048533-003	IRB6700 300/2.70, 245/3.00 Includes attachment screws and an assembly drawing.
Standard toolkit	-	
<i>Technical reference manual - System parameters</i>	-	Article number is specified in section References on page 10 .

Installation, mechanical stops axis 1

Use this procedure to fit the additional mechanical stops to axis 1 of the robot. An assembly drawing is also enclosed with the product.

	Action	Note
1	 DANGER Turn off all: <ul style="list-style-type: none"> • electric power supply to the robot • hydraulic pressure supply to the robot • air pressure supply to the robot Before entering the robot working area.	
2	Fit the additional mechanical stop to the frame according to the figure Mechanical stops, axis 1 on page 88 .	Tightening torque: 60 Nm.
3	Adjust the software working range limitations (system parameter configuration) to correspond to the mechanical limitations.	The system parameters that must be changed (<i>Upper joint bound</i> and <i>Lower joint bound</i>) are described in <i>Technical reference manual - System parameters</i> .
4	 WARNING If the mechanical stop pin is deformed after a hard collision, it must be replaced! Deformed <i>movable stops</i> and/or <i>additional stops</i> as well as deformed <i>attachment screws</i> must also be replaced after a hard collision.	

2 Installation and commissioning

2.6.1 Robot cabling and connection points

2.6 Electrical connections

2.6.1 Robot cabling and connection points

Introduction

Connect the robot and controller to each other after securing them to the foundation. The lists below specify which cables to use for each respective application.



DANGER

Turn off the main power before connecting any cables.



CAUTION

Verify that the robot serial number is according to the number(s) in the *Declaration of Incorporation (DoI)*.

Main cable categories

All cables between the robot and controller are divided into the following categories:

Cable category	Description
Robot cables	Handles power supply to and control of the robot's motors as well as feedback from the serial measurement board.
Fan cables (option)	Handles supply to and feedback from any cooling fan on the robot. Specified in the table Fan cables (option) on page 92 .
Customer cables (option)	Handles communication with equipment fitted on the robot by the customer, low voltage signals and high voltage power supply + protective ground. The customer cables also handle databus communication. See the product manual for the controller, see document number in References on page 10 .
DressPack cables (option)	Handles signals, process media and power feeding for customer use, regarding material handling or spot welding. See the <i>Product manual - DressPack/SpotPack IRB 6700</i> , see document number in References on page 10 .

Robot cables

These cables are included in the standard delivery. They are completely pre-manufactured and ready to plug in.

Cable sub-category	Description	Connection point, cabinet	Connection point, robot
Robot cable, power	Transfers drive power from the drive units in the controller to the robot motors.	XS1	R1.MP
Robot cable, signals	Transfers resolver data from and power supply to the serial measurement board.	XS2	R1.SMB

Continues on next page

2 Installation and commissioning

2.6.1 Robot cabling and connection points

Continued

Robot cable, power

Power cable length	Article number
7 m	3HAC026787-001
15 m	3HAC026787-002
22 m	3HAC026787-003
30 m	3HAC026787-004

Robot cable, signals

Signal cable length	Article number
7 m	3HAC068917-001
15 m	3HAC068918-001
22 m	3HAC068919-001
30 m	3HAC068920-001

Bending radius for static floor cables

The minimum bending radius is 10 times the cable diameter for static floor cables.

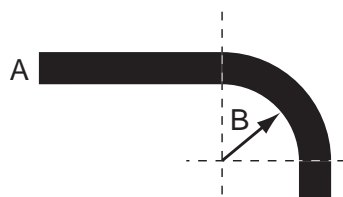

xx1600002016

A	Diameter
B	Diameter x10

Continues on next page

2 Installation and commissioning

2.6.1 Robot cabling and connection points

Continued

Grounding and bonding point on manipulator

There is a grounding/bonding point on the manipulator base. The grounding/bonding point is used for potential equalizing between control cabinet, manipulator and any peripheral devices.

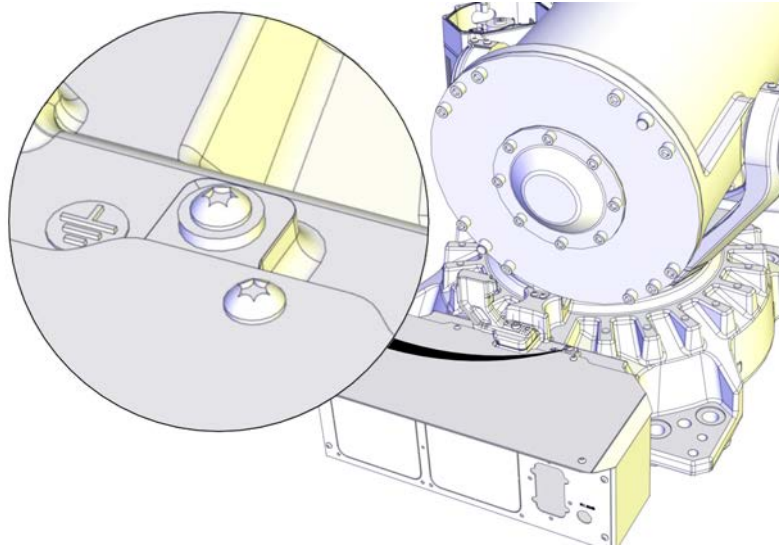

xx1500001600



Note

How to ground DressPack/SpotPack cables is detailed in the *Product manual - DressPack/SpotPack IRB 6700*, see the document number in [References on page 10](#).

Fan cables (option)

These cables are *not* included in the standard delivery, but are included in the delivery if the fan option is ordered. The cables are completely pre-manufactured and ready to plug in.

Cabling to be installed on the robot is specified in section [Installing the motor cooling fan \(option\) on page 95](#).

Cabling between robot base and control cabinet, cooling fans

The cables specified below are specific for the IRC5 controller and used when the robot is equipped with cooling fans. The cabling for the cooling fans runs all the way from the robot base to the inside of the cabinet. Fans can also be ordered without cables.

If equipping the robot with cooling fans, use the cabling specified below. The cables for cooling fans listed below are used together with a distributing cable, also specified below.

Cable	Art. no.	Connection point
Harness - cooling, 7 m	3HAC022723-001	Distributing cable: R1.FAN.SW2/3 Inside cabinet: A43.X10 and A43.X11

Continues on next page

2 Installation and commissioning

2.6.1 Robot cabling and connection points

Continued

Cable	Art. no.	Connection point
Harness - cooling, 15 m	3HAC022723-004	Distributing cable: R1.FAN.SW2/3 Inside cabinet: A43.X10 and A43.X11
Harness - cooling, 22 m	3HAC022723-005	Distributing cable: R1.FAN.SW2/3 Inside cabinet: A43.X10 and A43.X11
Harness - cooling, 30 m	3HAC022723-006	Distributing cable: R1.FAN.SW2/3 Inside cabinet: A43.X10 and A43.X11

2 Installation and commissioning

2.7.1 Signal lamp (option)

2.7 Installation of options

2.7.1 Signal lamp (option)

Description

A signal lamp with a yellow fixed light can be mounted on the robot, as a safety device.

Installation

See the assembly instruction delivered with the signal lamp.

Function

The lamp is active in MOTORS ON mode.

Further information

Further information about the MOTORS ON/MOTORS OFF mode may be found in the product manual for the controller.

2.7.2 Installing the motor cooling fan (option)

Location of the axis-1 motor cooling fan

A cooling fan can be installed on the axis-1 motor as an option. The fan is not possible to install on a robot with protection type Foundry Plus.

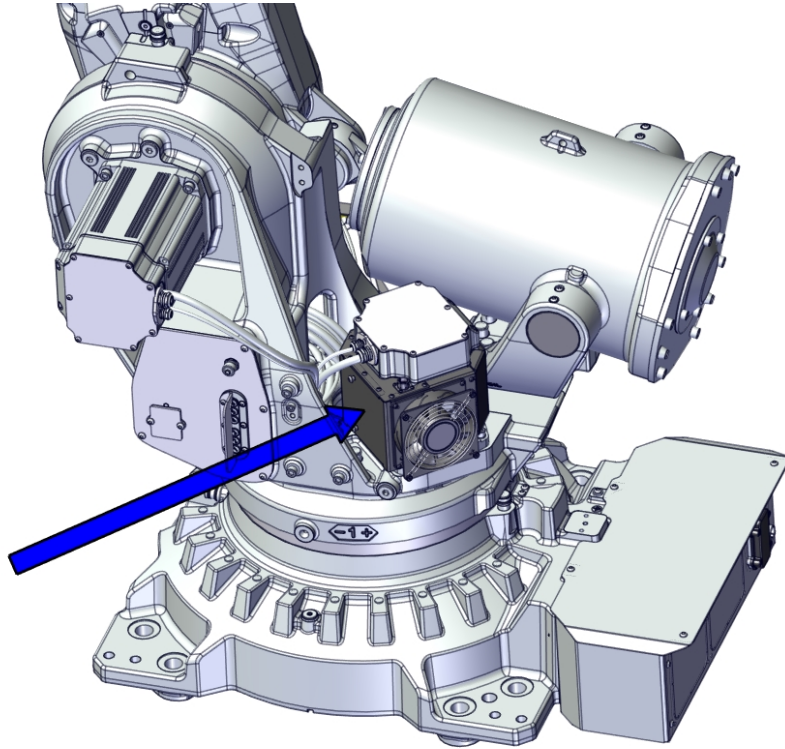

xx180000156

Required spare parts



Note

The spare part numbers that are listed in the table can be out of date. See the latest spare parts of the IRB 6700 via myABB Business Portal, www.abb.com/myABB.

Spare part	Article number	Note
Fan unit set	3HAC051149-001	Only available for the axis-1 motor. Can not be used together with protection type Foundry Plus. Includes fan unit, fan cable harness, customer connection plate and required fasteners.

Required tools and equipment

Equipment	Article number	Note
Standard toolkit	-	Content is defined in section Standard toolkit on page 814 .

Continues on next page

2 Installation and commissioning

2.7.2 Installing the motor cooling fan (option)

Continued

Required consumables

Consumable	Article number	Note
Cable straps	-	

Installing the cooling fan

Use these procedures to install the cooling fan.

Installing the fan

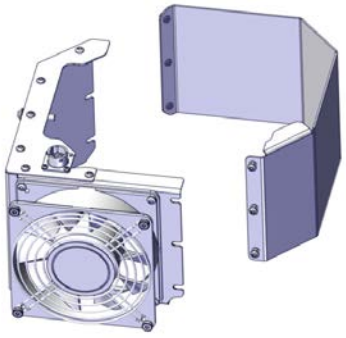
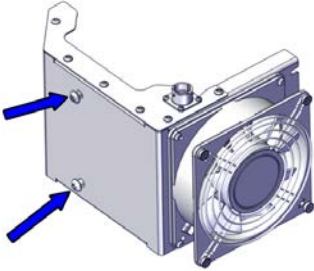
	Action	Note
1	Move the robot to its synchronization position.	
2	 DANGER Turn off all: <ul style="list-style-type: none"> • electric power supply • hydraulic pressure supply • air pressure supply to the robot, before entering the safeguarded space.	
3	Remove the metal sheet frame from the fan unit assembly by loosening the six screws.	 xx1800000157
4	Loosen the two tightening screws so they don't damage the motor surface during installation.	 xx1800000159

Continues on next page

2 Installation and commissioning

2.7.2 Installing the motor cooling fan (option)

Continued

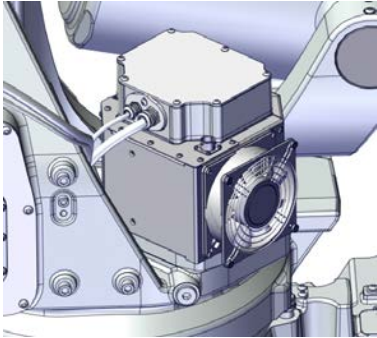
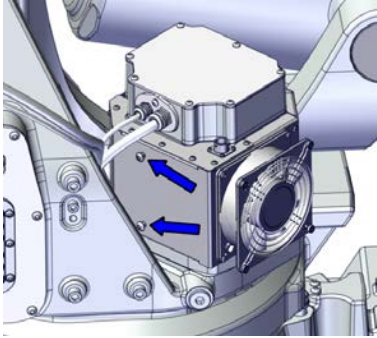
	Action	Note
5	Fit the fan unit sheets around the motor and fasten them to each other by tightening the six screws.	 <p>xx1800000158</p>
6	Lift the box so that it does not rest directly on the robot and secure the box against the motor with the two tightening screws. Tighten them properly so that the box is firmly attached to the motor.	 <p>xx1800000160</p>

Connecting the fan cabling

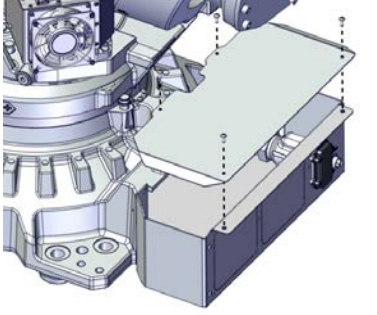
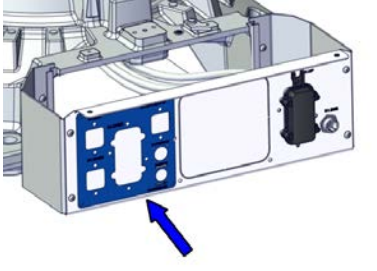
	Action	Note
1	Remove the rear cover plate.	 <p>xx1800000161</p>
2	Fit the customer connection plate.	 <p>xx1800000162</p>

Continues on next page

2 Installation and commissioning

2.7.2 Installing the motor cooling fan (option)

Continued

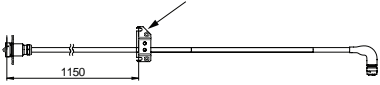
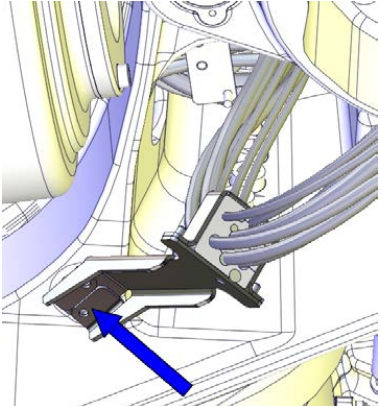
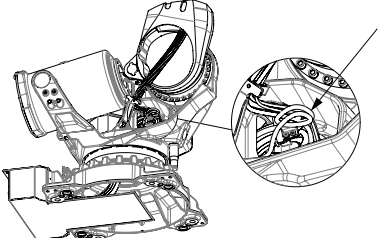
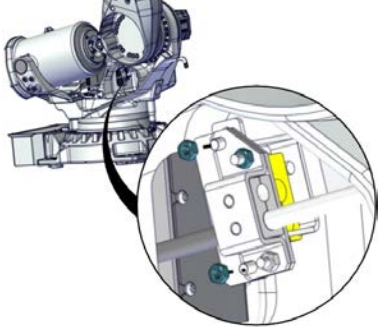
	Action	Note
3	<p>The bracket on the delivered fan cable must be fitted at a distance of 1,150 mm from the base connector.</p> <p>If adjustment is needed: measure the distance and make a mark with a pen or a piece of self adhesive. Loosen the cable bracket nuts and move the bracket to the mark. Tighten the nuts with 10 Nm after adjustment.</p>	 <p>xx1800000163</p>
4	<p>Loosen the frame cable clamp by unscrewing the screws.</p>	 <p>xx1300000542</p>
5	<p>Run the cabling up through the base and frame. Make a loop of the fan cable and use cable straps to strap it to the other cables.</p>	<p>Cable straps</p>  <p>xx1800000164</p>
6	<p>Secure the cable bracket inside the frame with the two enclosed nuts.</p>	 <p>xx1800000166</p>

Continues on next page

2 Installation and commissioning

2.7.2 Installing the motor cooling fan (option)

Continued

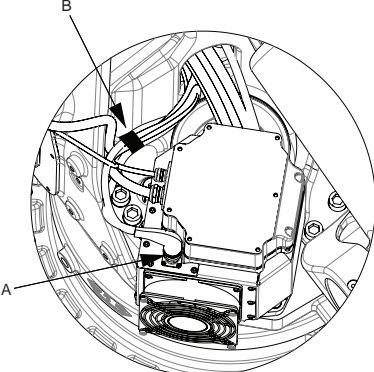
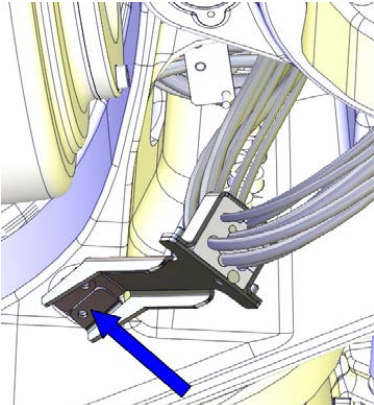
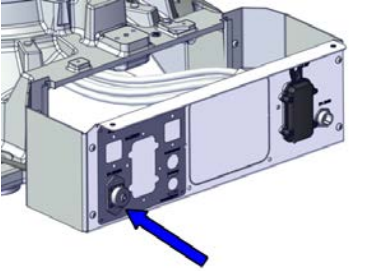
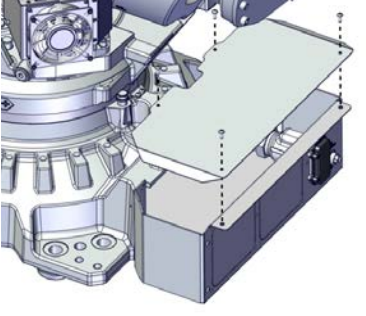
	Action	Note
7	Run the cable out through the side of the frame, at the axis-1 motor and connect the fan cable connector to the cooling fan.	 <p data-bbox="1061 694 1165 716">xx1800000165</p> <p data-bbox="1093 728 1364 795"> A Fan cable connector B Cable straps </p>
8	Strap the fan cable to the axis-1 and axis-2 motor cables.	
9	Refit the frame cable clamp with the screws.	 <p data-bbox="1061 1220 1165 1243">xx1300000542</p>
10	Connect the connector R1.SW2/3 to the base of the robot. Make sure that the cabling, run through the frame and base, is not twisted and runs freely from the robot cabling.	 <p data-bbox="1061 1556 1165 1579">xx1800000167</p>
11	Refit the rear cover plate to the robot base.	 <p data-bbox="1061 1937 1165 1960">xx1800000161</p>

Continues on next page

2 Installation and commissioning

2.7.2 Installing the motor cooling fan (option)

Continued

	Action	Note
12	Install additional cabling to and inside the controller.	Cabling and connection points are specified in Fan cables (option) on page 92 .

Adjustments in RobotWare

	Action	Note
1	Modify the settings in RobotWare to include the cooling fans.	Change the settings by using the Modify Controller System Wizard in the System Builder of RobotStudio. Read more about modifying the system in <i>Operating manual - RobotStudio</i> .

2.8 Start of robot in cold environments

Introduction

This section describes how to start the robot in a cold environment if it is not starting the normal way.

Problems with starting the robot

Event message from Motion Supervision

Use this procedure if an event message indicates a problem with Motion supervision at start-up. More information about Motion Supervision is found in *Technical reference manual - System parameters*.

	Action	Note
1	Turn off Motion Supervision.	
2	Start the robot.	
3	When the robot has reached normal working temperature, the Motion Supervision can be turned on again.	

Robot stopping with other event message

Use this procedure if the robot is not starting.

	Action	Note
1	Start the robot with its normal program but with reduced speed.	The speed can be regulated with the RAPID instruction <code>VelSet</code> .

Adjusting the speed and acceleration during warm-up

Depending on how cold the environment is and what program is being used, the speed might need to be ramped up until reached maximum. The table shows examples of how to adjust the speed:

Work cycles	AccSet	Speed/velocity
3 Work cycles	20, 20	v100 (100 mm/s)
5 Work cycles	40, 40	v400 (400 mm/s)
5 Work cycles	60, 60	v600 (600 mm/s)
5 Work cycles	100, 100	v1000 (1000 mm/s)
More than 5 Work cycles	100, 100	Max.

If the program consists of large wrist movements, it is possible that the reorientation velocity, which is always high in predefined velocities, needs to be included in the ramping up.

This page is intentionally left blank

3 Maintenance

3.1 Introduction

Structure of this chapter

This chapter describes all the maintenance activities recommended for the IRB 6700.

It is based on the maintenance schedule found at the beginning of the chapter. The schedule contains information about required maintenance activities including intervals, and refers to procedures for the activities.

Each procedure contains all the information required to perform the activity, including required tools and materials.

The procedures are gathered in different sections and divided according to the maintenance activity.

Safety information

Observe all safety information before conducting any service work.

There are general safety aspects that must be read through, as well as more specific safety information that describes the danger and safety risks when performing the procedures. Read the chapter [Safety on page 19](#) before performing any service work.

The maintenance must be done by qualified personnel in accordance with the safety requirements set forth in the applicable national and regional standards and regulations.

**Note**

If the IRB 6700 is connected to power, always make sure that the IRB 6700 is connected to protective earth and a residual current device (RCD) before starting any maintenance work.

For more information see:

- *Product manual - OmniCore V250XT*
- *Product manual - IRC5*
- *Product manual - IRC5 Panel Mounted Controller*
- [Robot cabling and connection points on page 90.](#)

3 Maintenance

3.2.1 Specification of maintenance intervals

3.2 Maintenance schedule and expected component life

3.2.1 Specification of maintenance intervals

Introduction

The intervals are specified in different ways depending on the type of maintenance activity to be carried out and the working conditions of the IRB 6700:

- Calendar time: specified in months regardless of whether the system is running or not.
- Operating time: specified in operating hours. More frequent running means more frequent maintenance activities.

Robots with the functionality *Service Information System* activated can show active counters in the device browser in RobotStudio, or on the FlexPendant.

Overhaul

Depending on application and operational environment a complete overhaul may be necessary in average around 40000 hours.

ABB Connected Services and its Assessment tools can help you to identify the real stress level of your robot, and define the optimal ABB support to maintain your robot working.

Contact your local ABB Customer Service to get more information.

3.2.2 Maintenance schedule

Scheduled and non-predictable maintenance

The robot must be maintained regularly to ensure proper function. The maintenance activities and intervals are specified in the table below.

Non-predictable situations also give rise to inspections of the robot. Any damages must be attended to immediately!

Life of each component

The inspection intervals *do not* specify the life of each component. Values for these are specified in the section [Expected component life on page 107](#)

Activities and intervals, standard equipment

The table below specifies the required maintenance activities and intervals:

Maintenance activities	Regularly	Every 6 months	Every 12 months	Every 18 months	Every 24 months	Every 36 months	Every 12,000 hours ⁱ	Every 20,000 hours ⁱ	Every 40,000 hours ⁱ	Reference
Cleaning activities										
Cleaning the robot	x									Cleaning the IRB 6700 on page 182
Inspection activities										
Inspecting the motor seal ⁱⁱ			x							Inspecting the motor seal on page 108
Inspecting the oil level in gearboxes										Inspect the oil level in the actual gearbox if there is a suspected leakage, after an oil change or a maintenance or repair activity where draining and filling oil is required.
Inspecting the balancing device			x							Inspecting the balancing device on page 127
Inspecting the robot harness			x ⁱⁱⁱ							Inspecting the cable harness on page 131
Inspecting the information labels			x							Inspecting the information labels on page 133
Inspecting the dampers			x							Inspecting the dampers on page 141
Inspecting the mechanical stop			x							Inspecting the axis-1 mechanical stop pin on page 137
Replacement/changing activities										

Continues on next page

3 Maintenance

3.2.2 Maintenance schedule

Continued

Maintenance activities	Regularly	Every 6 months	Every 12 months	Every 18 months	Every 24 months	Every 36 months	Every 12,000 hours ⁱ	Every 20,000 hours ⁱ	Every 40,000 hours ⁱ	Reference
Changing the oil in axis-1 gearbox								x		Changing oil, axis-1 gearbox on page 147
Changing the oil in axis-2 gearbox								x		Changing oil, axis-2 gearbox on page 154
Changing the oil in axis-3 gearbox								x		Changing oil, axis-3 gearbox on page 159
Changing the oil in axis-4 gearbox								x		Changing oil, axis-4 gearbox on page 165
Changing the oil in axis-5 gearbox								x		Changing oil, axis-5 gearbox on page 169
Changing the oil in axis-6 gearbox								x		Changing oil, axis-6 gearbox on page 173
Replacing the SMB battery pack						x ^{iv}				Replacing the SMB battery on page 177
Lubrication activities										
Lubricating the balancing device bearings							x ^v			Lubricating the spherical roller bearing, balancing device on page 180
Overhaul										
Overhaul of complete robot									x	

- i Operating hours counted by the DTC = Duty time counter.
- ii Only valid for robots that are equipped with Type B motors.
Type B motors include evacuation on the motor flange to indicate failure of primary sealing between the gearbox and the motor. Robots with protection type Foundry Plus have a sight glass installed in the evacuation holes.
[See Type A vs type B motors on page 805.](#)
- iii Replace when damage or cracks is detected or life limit is approaching that specified in section [Expected component life on page 107.](#)
- iv The battery is to be replaced at given maintenance interval or at battery low alert.
- v Always lubricate the front eye bearing after refitting the shaft of the balancing device.

3.2.3 Expected component life

General

The expected life of a specific component of the robot can vary greatly depending on how hard it is run.

Expected component life - protection type Standard

Component	Expected life	Note
Cable harness Normal usage ⁱ	40,000 hours ⁱⁱ	Not including: <ul style="list-style-type: none"> • Possible SpotPack harnesses • Optional upper arm harnesses
Cable harness Extreme usage ⁱⁱⁱ	20,000 hours ⁱⁱ	Not including: <ul style="list-style-type: none"> • Possible SpotPack harnesses • Optional upper arm harnesses
Balancing device	40,000 hours ^{iv}	
Gearboxes ^v	40,000 hours	

ⁱ Examples of "normal usage" in regard to movement: most material handling applications.

ⁱⁱ Severe chemical or thermal environments, or similar environments, can result in shortened life expectancy.

ⁱⁱⁱ Examples of "extreme usage" in regard to movement: press tending, very severe palletizing applications, major use of axis 1 movement.

^{iv} The given life for the balancing device is based on a test cycle of 4,000,000 cycles that starts from the initial position and goes to maximum extension, and back. Deviations from this cycle will result in differences in expected life!

^v The SIS for an IRC5 system is described in the *Operating manual - Service Information System*.

3 Maintenance

3.3.1 Inspecting the motor seal

3.3 Inspection activities

3.3.1 Inspecting the motor seal

Purpose of evacuation holes

This section is only valid for robots that are equipped with Type B motors.

The motors include evacuation on the motor flange to indicate failure of primary sealing between the gearbox and the motor.

More information is found in [Type A vs type B motors on page 805](#).

Location of evacuation hole on motor

The evacuation hole is located on each motor flange. The figure shows axis-1 motor as an example.

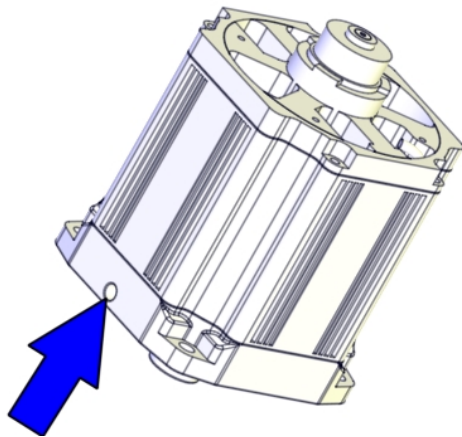

xx1500001057

Plug in the evacuation hole

Robots with protection type Standard have a protection filter installed in the evacuation hole.

Robots with protection type Foundry Plus have a transparent plug/sight glass installed in the evacuation holes.



xx1800000101

Protection filter (Standard).





xx1800000102

Transparent plug (Foundry Plus).

Continues on next page

Inspecting the evacuation hole

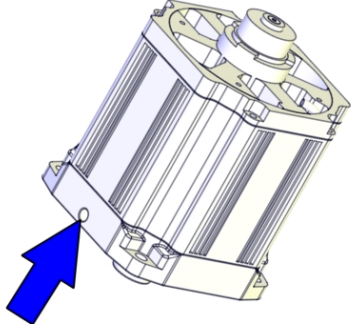
	Action	Note
1	 <p>DANGER</p> <p>Turn off all:</p> <ul style="list-style-type: none"> • electric power supply • hydraulic pressure supply • air pressure supply <p>to the robot, before entering the robot working area.</p>	
2	 <p>WARNING</p> <p>Handling gearbox oil involves several safety risks, see Gearbox lubricants (oil or grease) on page 34.</p>	
3	<p>Do a leakage check of the sight glass/evacuation hole of each motor.</p> <p>If any oil is available on the sight glass or if any oil has been spilled out from the evacuation hole, replacement of the motor is recommended.</p>	 <p>xx1500001057</p> <p>Replacing of motors is described in the repair chapter Motors on page 483.</p>

3 Maintenance

3.3.2 Inspecting the oil level in axis-1 gearbox

3.3.2 Inspecting the oil level in axis-1 gearbox

Location of oil plug

The oil plug through which the oil level is inspected is located as shown in the figure.

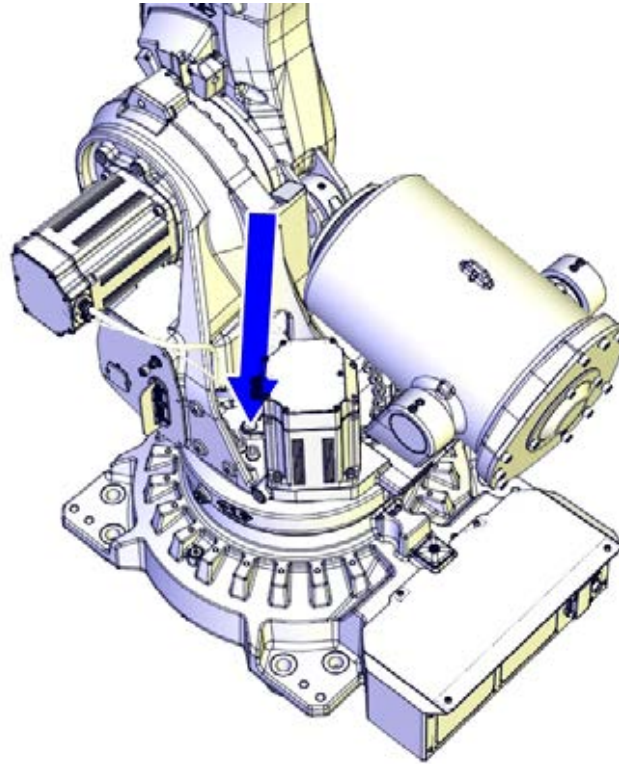

xx120000950

IRB 6700 - 235/2.65, IRB 6700 - 205/2.80, IRB 6700 - 175/3.05, IRB 6700 - 150/3.20,
IRB 6700 - 200/2.60, IRB 6700 - 155/2.85

Continues on next page

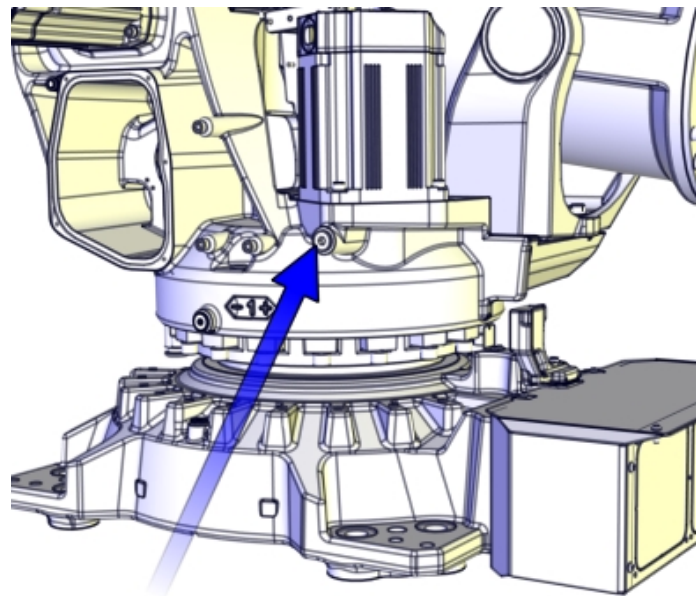

xx1500001655

IRB 6700 - 300/2.70, IRB 6700 - 245/3.00

Required tools

Equipment	Article number	Note
Standard toolkit	-	Content is defined in section Standard toolkit on page 814 .

Required consumables

Consumables	Article number	Note
Lubricating oil	-	Information about the oil is found in <i>Technical reference manual - Lubrication in gearboxes</i> .

Required documents

Document name	Document number
<i>Technical reference manual - Lubrication in gearboxes</i>	3HAC042927-001

Continues on next page



3 Maintenance

3.3.2 Inspecting the oil level in axis-1 gearbox

Continued

Inspecting the oil level in axis-1 gearbox

Use this procedure to inspect the oil level in the gearbox.

	Action	Note
1	 DANGER Turn off all: <ul style="list-style-type: none">• electric power supply• hydraulic pressure supply• air pressure supply to the robot, before entering the robot working area.	
2	 WARNING Handling gearbox oil involves several safety risks, see Gearbox lubricants (oil or grease) on page 34 .	
3	Make sure that the oil temperature is $+25^{\circ}\text{C} \pm 10^{\circ}\text{C}$.	

Continues on next page

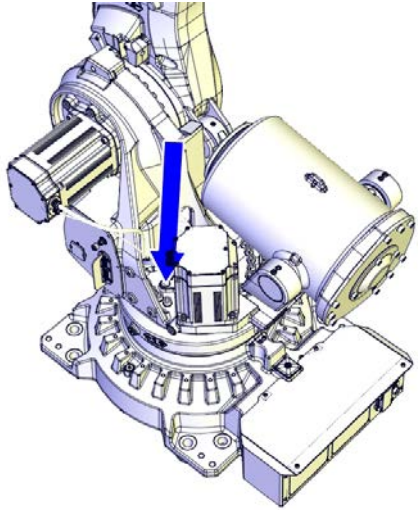
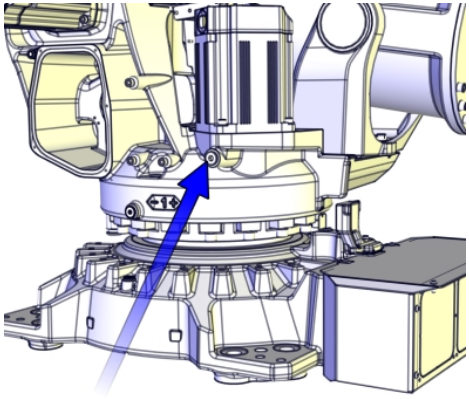
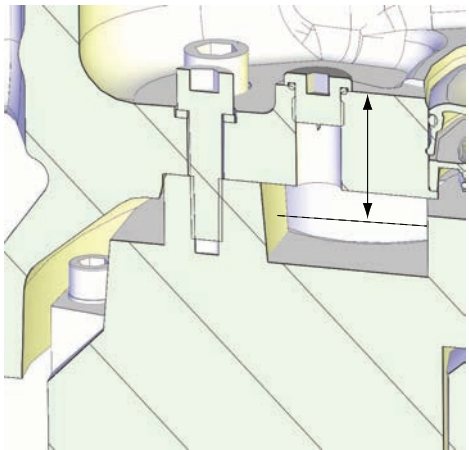
	Action	Note
4	Open the oil plug.	 <p data-bbox="970 831 1082 853">xx120000950</p> <p data-bbox="970 869 1430 949">IRB 6700 - 235/2.65, IRB 6700 - 205/2.80, IRB 6700 - 175/3.05, IRB 6700 - 150/3.20, IRB 6700 - 200/2.60, IRB 6700 - 155/2.85</p>  <p data-bbox="970 1368 1082 1391">xx1500001655</p> <p data-bbox="970 1406 1430 1435">IRB 6700 - 300/2.70, IRB 6700 - 245/3.00</p>
5	<p data-bbox="496 1451 954 1541">IRB 6700 - 235/2.65, IRB 6700 - 205/2.80, IRB 6700 - 175/3.05, IRB 6700 - 150/3.20 IRB 6700 - 200/2.60, IRB 6700 - 155/2.85</p> <p data-bbox="496 1547 711 1576">Check the oil level.</p> <p data-bbox="496 1583 962 1637">Required oil level is: 58 mm ± 5 mm below the sealing surface of the oil plug.</p>	 <p data-bbox="970 1906 1082 1928">xx130000692</p>

Continues on next page

3 Maintenance

3.3.2 Inspecting the oil level in axis-1 gearbox

Continued

	Action	Note
6	IRB 6700 - 300/2.70, IRB 6700 - 245/3.00 Check the oil level. Required oil level is: 0 - 10 mm below the oil plug hole.	
7	Add or drain oil, if required.	Type of oil and total amount is detailed in <i>Technical reference manual - Lubrication in gearboxes</i> . Further information about how to drain or fill with oil is found in section Changing oil, axis-1 gearbox on page 147 .
8	Refit the oil plug.	Tightening torque: 24 Nm.
9	 DANGER Make sure all safety requirements are met when performing the first test run.	

3.3.3 Inspecting the oil level in axis-2 gearbox

Location of the oil plug

The oil plug for inspection is located as shown in the figure.

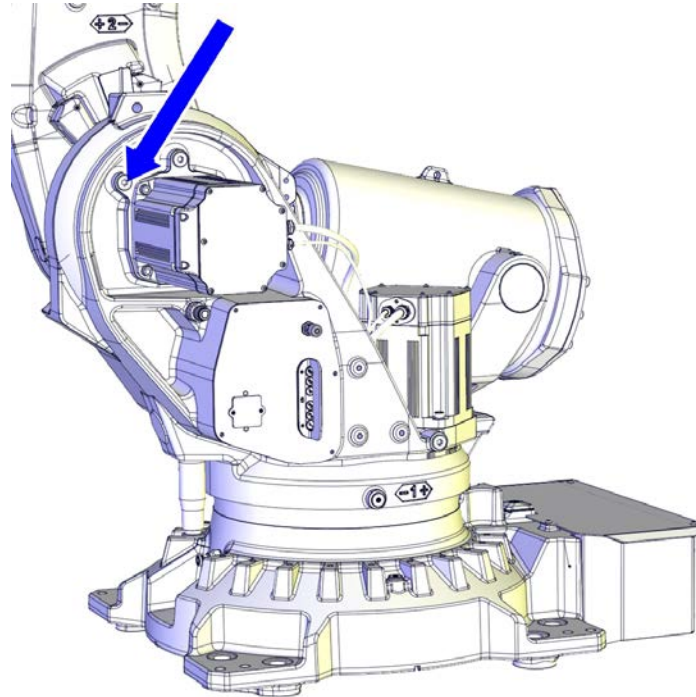

xx120000952

Tightening torque: 24 Nm

Required tools and equipment

Equipment	Article number	Note
Standard toolkit	-	Content is defined in section Standard toolkit on page 814 .

Required consumables

Consumables	Article number	Note
Lubricating oil	-	Information about the oil is found in <i>Technical reference manual - Lubrication in gearboxes</i> .

Required documents

Document name	Document number
<i>Technical reference manual - Lubrication in gearboxes</i>	3HAC042927-001

Continues on next page





3 Maintenance

3.3.3 Inspecting the oil level in axis-2 gearbox

Continued

Inspecting the oil level in axis-2 gearbox

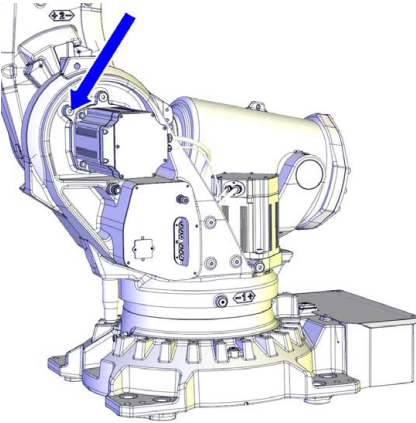
Use this procedure to inspect the oil level in the gearbox.

	Action	Note
1	 <p>DANGER</p> <p>Turn off all:</p> <ul style="list-style-type: none"> • electric power supply • hydraulic pressure supply • air pressure supply <p>to the robot, before entering the robot working area.</p>	
2	 <p>WARNING</p> <p>Handling gearbox oil involves several safety risks, see Gearbox lubricants (oil or grease) on page 34.</p>	
3	<p>Make sure that the oil temperature is $+25^{\circ}\text{C} \pm 10^{\circ}\text{C}$.</p>	
4	<p>Open the oil plug.</p>	 <p>xx1200000952</p>
5	<p>Check the oil level. Required oil level is: 0-15 mm below the oil plug hole.</p>	
6	<p>Add or drain oil, if required.</p>	<p>Type of oil and total amount is detailed in <i>Technical reference manual - Lubrication in gearboxes</i>. Further information about how to drain or fill with oil is found in section Changing oil, axis-2 gearbox on page 154.</p>
7	<p>Refit the oil plug.</p>	<p>Tightening torque: 24 Nm.</p>
8	 <p>DANGER</p> <p>Make sure all safety requirements are met when performing the first test run.</p>	

3.3.4 Inspecting the oil level in axis-3 gearbox

Location of oil plug

The gearbox has a level plug that is located as shown in the figure.

IRB 6700 - 235/2.65, IRB 6700 - 205/2.80, IRB 6700 - 175/3.05, IRB 6700 - 150/3.20,
IRB 6700 - 200/2.60, IRB 6700 - 155/2.85

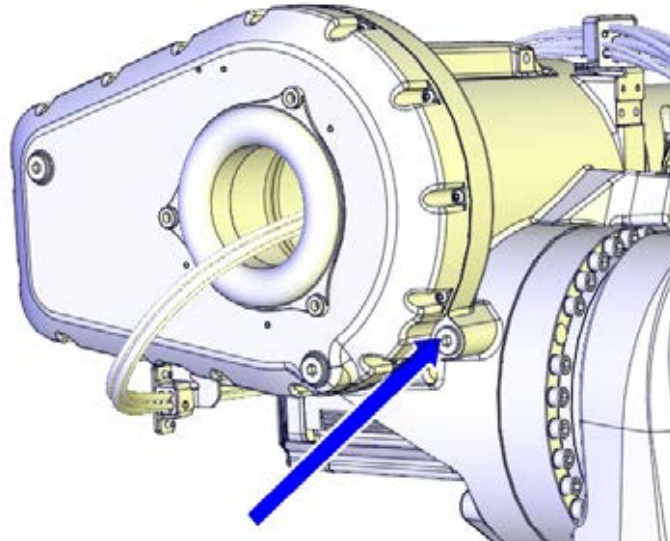

xx120000955

IRB 6700 - 300/2.70, IRB 6700 - 245/3.00

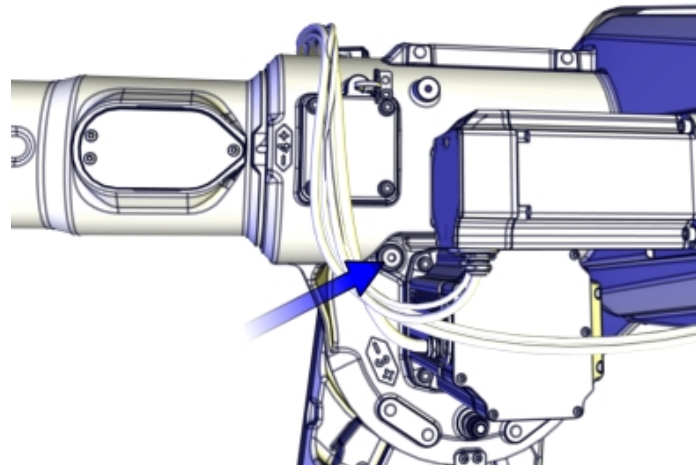

xx1500001645

Tightening torque: 24 Nm

Required tools

Equipment, etc.	Article number	Note
Standard toolkit	-	Content is defined in section Standard toolkit on page 814 .

Continues on next page

3 Maintenance

3.3.4 Inspecting the oil level in axis-3 gearbox

Continued

Required consumables



Consumables	Article number	Note
Lubricating oil	-	Information about the oil is found in <i>Technical reference manual - Lubrication in gearboxes</i> .

Required documents

Document name	Document number
<i>Technical reference manual - Lubrication in gearboxes</i>	3HAC042927-001

Inspecting the oil level in axis-3 gearbox

Use this procedure to inspect the oil level in the gearbox.

	Action	Note
1	Run the robot to calibration position.	
2	 DANGER Turn off all: <ul style="list-style-type: none">• electric power supply• hydraulic pressure supply• air pressure supply to the robot, before entering the robot working area.	
3	Make sure that the oil temperature is +25°C ± 10°C.	
4	 WARNING Handling gearbox oil involves several safety risks, see Gearbox lubricants (oil or grease) on page 34 .	

Continues on next page

Action	Note
5	<p>Open the oil plug.</p>
<div data-bbox="986 322 1439 680" data-label="Image"> </div> <p data-bbox="970 689 1078 707">xx120000955</p> <p data-bbox="970 725 1430 806">IRB 6700 - 235/2.65, IRB 6700 - 205/2.80, IRB 6700 - 175/3.05, IRB 6700 - 150/3.20, IRB 6700 - 200/2.60, IRB 6700 - 155/2.85</p> <div data-bbox="970 833 1439 1137" data-label="Image"> </div> <p data-bbox="970 1146 1078 1164">xx1500001645</p> <p data-bbox="970 1182 1423 1214">IRB 6700 - 300/2.70, IRB 6700 - 245/3.00</p>	
6	<p>Check the oil level. Required oil level is: 0 - 20 mm below the oil plug hole.</p>
7	<p>Add or drain oil, if required.</p>
<p data-bbox="970 1335 1433 1415">Type of oil and total amount is detailed in <i>Technical reference manual - Lubrication in gearboxes</i>.</p> <p data-bbox="970 1424 1439 1505">Further information about how to drain or fill with oil is found in section <i>Changing oil, axis-3 gearbox on page 159</i>.</p>	
8	<p>Refit the oil plug.</p>
<p data-bbox="970 1523 1264 1554">Tightening torque: 24 Nm.</p>	
9	<p data-bbox="501 1581 695 1644">  DANGER </p> <p data-bbox="494 1662 963 1715">Make sure all safety requirements are met when performing the first test run.</p>

3 Maintenance

3.3.5 Inspecting the oil level in axis-4 gearbox

3.3.5 Inspecting the oil level in axis-4 gearbox

Location of oil plug

The gearbox has a level plug that is located as shown in the figure.

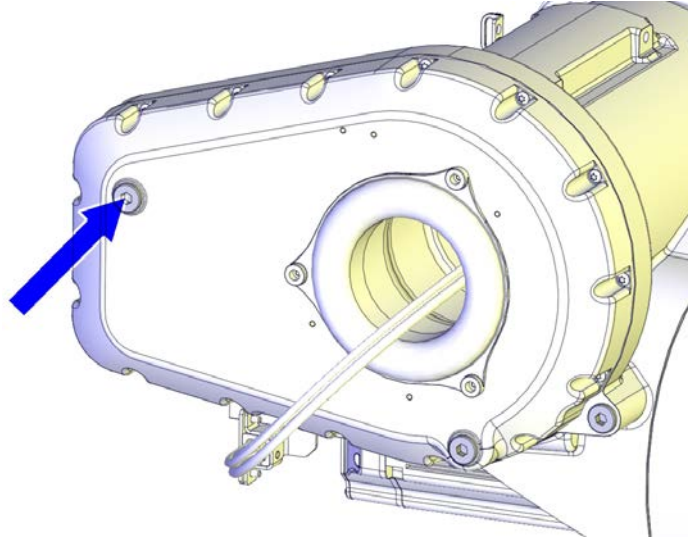

xx120000957

Tightening torque: 24 Nm

Required tools

Equipment, etc.	Article number	Note
Standard toolkit	-	Content is defined in section Standard toolkit on page 814 .

Required consumables

Consumables	Article number	Note
Lubricating oil	-	Information about the oil is found in <i>Technical reference manual - Lubrication in gearboxes</i> .

Required documents





Document name	Document number
<i>Technical reference manual - Lubrication in gearboxes</i>	3HAC042927-001

Inspecting the oil level in axis-4 gearbox

Use this procedure to inspect the oil level in the gearbox.

	Action	Note
1	Run the robot to calibration position.	

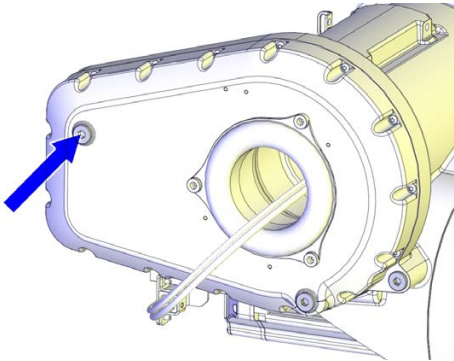
Continues on next page

	Action	Note
2	<p> DANGER</p> <p>Turn off all:</p> <ul style="list-style-type: none"> • electric power supply • hydraulic pressure supply • air pressure supply <p>to the robot, before entering the robot working area.</p>	
3	<p>Make sure that the oil temperature is $+25^{\circ}\text{C} \pm 10^{\circ}\text{C}$.</p>	
4	<p> WARNING</p> <p>Handling gearbox oil involves several safety risks, see Gearbox lubricants (oil or grease) on page 34.</p>	
5	<p>Open the oil plug.</p>	 <p>xx1200000957</p>
6	<p>Check the oil level. Required oil level is: 0 - 10 mm below the oil plug hole.</p>	
7	<p>Add or drain oil, if required.</p>	<p>Type of oil and total amount is detailed in <i>Technical reference manual - Lubrication in gearboxes</i>.</p> <p>Further information about how to drain or fill with oil is found in section Changing oil, axis-4 gearbox on page 165.</p>
8	<p>Refit the oil plug.</p>	<p>Tightening torque: 24 Nm.</p>
9	<p> DANGER</p> <p>Make sure all safety requirements are met when performing the first test run.</p>	

3 Maintenance

3.3.6 Inspecting the oil level in axis-5 gearbox

3.3.6 Inspecting the oil level in axis-5 gearbox

Location of oil plug

The gearbox has a level plug that is located as shown in the figure.

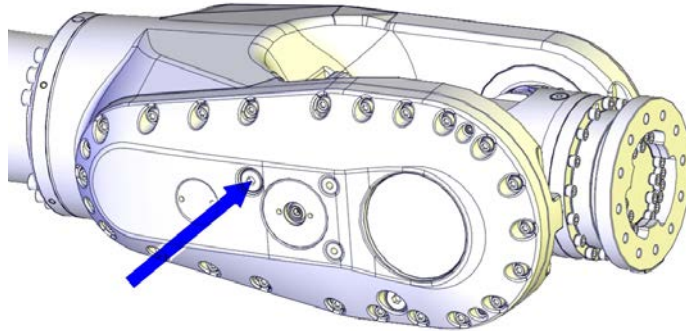

xx120000959

Tightening torque: 24 Nm

Required tools

Equipment, etc.	Article number	Note
Standard toolkit	-	Content is defined in section Standard toolkit on page 814 .

Required consumables

Consumables	Article number	Note
Lubricating oil	-	Information about the oil is found in <i>Technical reference manual - Lubrication in gearboxes</i> .

Required documents





Document name	Document number
<i>Technical reference manual - Lubrication in gearboxes</i>	3HAC042927-001

Inspecting the oil level in axis-5 gearbox

Use this procedure to inspect the oil level in the gearbox.

Action	Note
1 Run the robot to calibration position.	

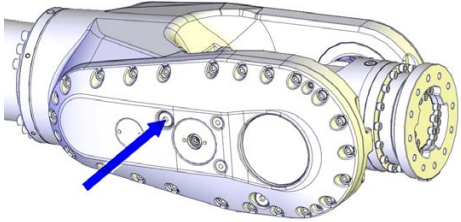
Continues on next page

	Action	Note
2	<p> DANGER</p> <p>Turn off all:</p> <ul style="list-style-type: none"> • electric power supply • hydraulic pressure supply • air pressure supply <p>to the robot, before entering the robot working area.</p>	
3	<p>Make sure that the oil temperature is $+25^{\circ}\text{C} \pm 10^{\circ}\text{C}$.</p>	
4	<p> WARNING</p> <p>Handling gearbox oil involves several safety risks, see Gearbox lubricants (oil or grease) on page 34.</p>	
5	<p>Open the oil plug.</p>	 <p>xx1200000959</p>
6	<p>Check the oil level. Required oil level is: 0 - 10 mm below the oil plug hole.</p>	
7	<p>Add or drain oil, if required.</p>	<p>Type of oil and total amount is detailed in <i>Technical reference manual - Lubrication in gearboxes</i>.</p> <p>Further information about how to drain or fill with oil is found in section Changing oil, axis-5 gearbox on page 169.</p>
8	<p>Refit the oil plug.</p>	<p>Tightening torque: 24 Nm.</p>
9	<p> DANGER</p> <p>Make sure all safety requirements are met when performing the first test run.</p>	

3 Maintenance

3.3.7 Inspecting the oil level in axis-6 gearbox

3.3.7 Inspecting the oil level in axis-6 gearbox

Location of oil plug

The oil plug through which the oil level is inspected is located as shown in the figure.

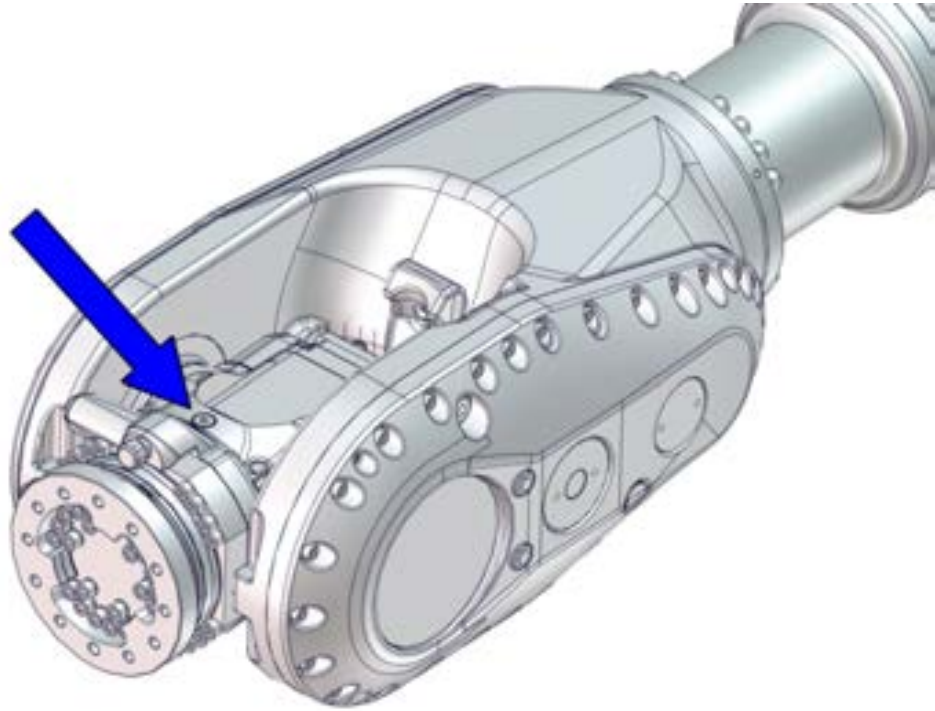

xx1600002049

Tightening torque: 24 Nm

Required tools

Equipment, etc.	Article number	Note
Standard toolkit	-	Content is defined in section Standard toolkit on page 814 .

Required consumables

Consumable	Article number	Note
Lubricating oil	-	Information about the oil is found in <i>Technical reference manual - Lubrication in gearboxes</i> .

Required documents



Document name	Document number
<i>Technical reference manual - Lubrication in gearboxes</i>	3HAC042927-001

Continues on next page

Inspecting the oil level in axis-6 gearbox

Use this procedure to inspect the oil level in the gearbox.

The procedure includes two alternative positions for axis 5, where one of the positions makes it possible to use the filling plug as a level plug.

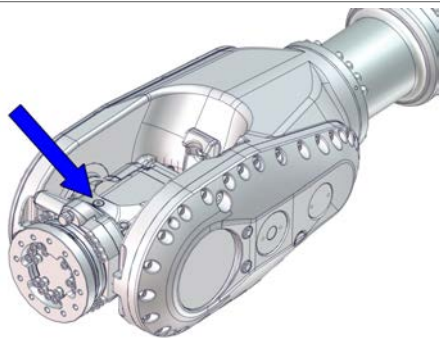
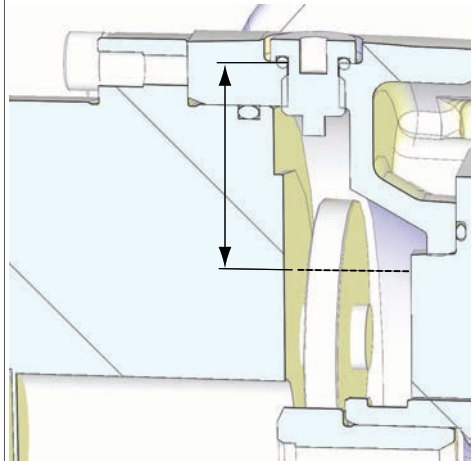
	Action	Note
1	Run the robot to calibration position.	
2	 DANGER Turn off all: <ul style="list-style-type: none"> • electric power supply • hydraulic pressure supply • air pressure supply to the robot, before entering the robot working area.	
3	Make sure that the oil temperature is $+25^{\circ}\text{C} \pm 10^{\circ}\text{C}$.	
4	 WARNING Handling gearbox oil involves several safety risks, see Gearbox lubricants (oil or grease) on page 34 .	
5	Open the oil plug.	 xx1600002049
6	Method 1 Check the oil level. Required oil level is: <ul style="list-style-type: none"> • IRB 6700 - 235/2.65, IRB 6700 - 205/2.80, IRB 6700 - 175/3.05, IRB 6700 - 150/3.20 50 mm \pm 5 mm below the sealing surface of the oil plug. • IRB 6700 - 200/2.60, IRB 6700 - 155/2.85 50 mm \pm 5 mm below the sealing surface of the oil plug. • IRB 6700 - 300/2.70, IRB 6700 - 245/3.00 45 mm \pm 5 mm below the sealing surface of the oil plug. 	 xx1300000693

Continues on next page

3 Maintenance

3.3.7 Inspecting the oil level in axis-6 gearbox

Continued

	Action	Note
7	Method 2 Rotate axis 5 +77°. Required oil level is: 0 - 10 mm below the oil plug hole.	
8	Add or drain oil, if required.	Type of oil and total amount is detailed in <i>Technical reference manual - Lubrication in gearboxes</i> . Further information about how to drain or fill with oil is found in section Changing oil, axis-6 gearbox on page 173 .
9	Refit the oil plug.	Tightening torque: 24 Nm.
10	 DANGER Make sure all safety requirements are met when performing the first test run.	

3.3.8 Inspecting the balancing device

General

Several points are to be checked on the balancing device during the inspection. This section describes how to perform the inspection regarding:

- dissonance
- damage
- leakage
- contamination / lack of free space.

Inspection points, balancing device

The balancing device is located at the top rear of the frame as shown in the figure. The figure also shows the inspection points, further described in the instructions.

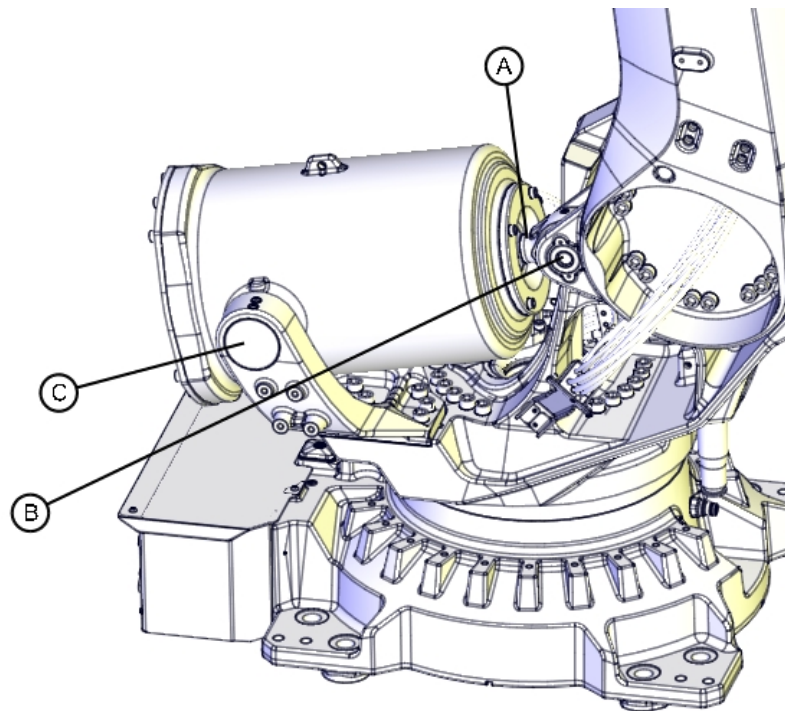

xx130000413

A	Piston rod (inside balancing device)
B	Link ear
C	Rear attachments of the balancing device (rear bearing)

Required tools

Visual inspection, no tools are required.

Continues on next page

3 Maintenance

3.3.8 Inspecting the balancing device

Continued

Required material

Equipment	Article number	Note
Maintenance kit, link ear	3HAC045815-001	The maintenance kit contains: <ul style="list-style-type: none">• End cover• Radial sealing with dust lip, 50x68x8 (2 pcs)• O-ring 85x3• Spherical roller bearing• Washer
Maintenance kit, cradle	3HAC045822-001	Includes: <ul style="list-style-type: none">• bearings and seals• VK cover.

Check for dissonance

The check points are shown in the figure [Inspection points, balancing device on page 127](#).

	Check points	Action
1	Check for dissonance from the bearing at the link ear and the bearings at the rear attachments.	If dissonance is detected, perform maintenance according to maintenance kits and instructions in section Replacing spherical roller bearing, link ear on page 430 and on page ? .
2	Check for dissonance from the balancing device (a tapping sound, caused by the springs inside the cylinder).	If dissonance is detected, replace the balancing device or consult ABB Service. How to replace the device is detailed in section Replacing the balancing device on page 448 . This section also specifies the spare part number.
3	Check for dissonance from the piston rod (squeaking may indicate worn plain bearings, internal contamination or insufficient lubrication).	If dissonance is detected, perform maintenance according to given instructions in Maintenance kit, complete.

Check for damage

Check for damage, such as scratches, general wear, uneven surfaces or incorrect positions.

The check points are shown in the figure [Inspection points, balancing device on page 127](#).

	Check points	Action
1	Check for damage on the part of the piston rod that is visible at the front of the balancing device.	If damage is detected, perform maintenance according to given instructions in Maintenance kit, complete.

Continues on next page

Check for leakage

Leaks at o-rings, radial sealings etc. are not acceptable and must be attended to immediately to avoid damage to the bearing.

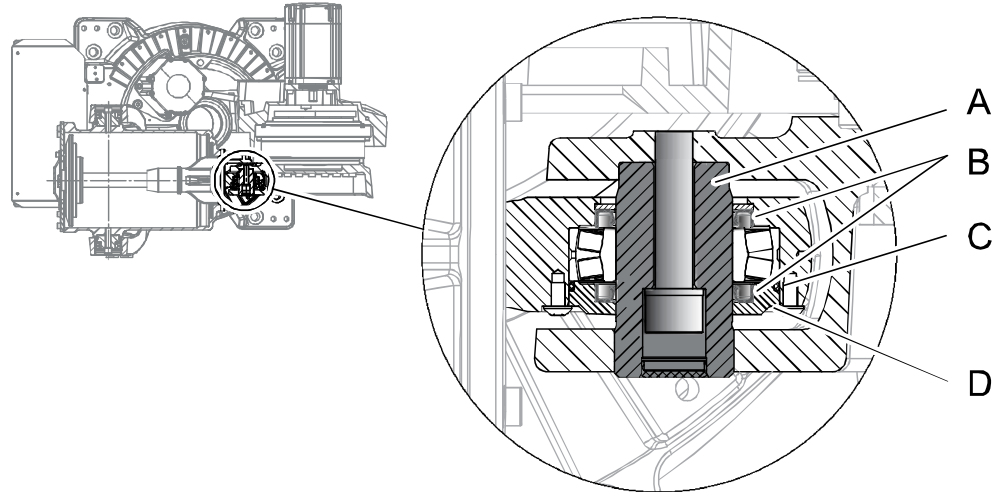

xx100000207

A	Shaft
B	Radial sealing with dust lip, 50x68x8 (2 pcs)
C	O-ring, 85x3
D	End cover

	Action	Note
1	Clean the area at the front ear from contamination.	
2	Run the robot for some minutes, in order to move the balancing device piston.	
3	 DANGER Turn off all: <ul style="list-style-type: none"> • electric power supply to the robot • hydraulic pressure supply to the robot • air pressure supply to the robot Before entering the robot working area.	
4	Check the area around the o-ring and radial sealings at the front ear, for leakage.	
5	Replace o-ring and radial sealings if leaks are detected.	The o-ring and radial sealings are included in the Maintenance kit, bearings and seals already assembled with sealing spacers and sealing rings. Article number for the kit is specified in Required material on page 128 . Replacement of the complete bearing is described in section Replacing the balancing device on page 448 .

Continues on next page

3 Maintenance

3.3.8 Inspecting the balancing device

Continued

Check for contamination / lack of free space

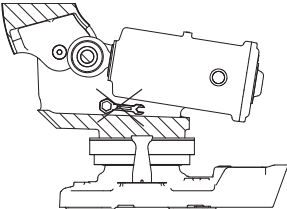
	Action	Note
1	<p> DANGER</p> <p>Turn off all:</p> <ul style="list-style-type: none">• electric power supply to the robot• hydraulic pressure supply to the robot• air pressure supply to the robot <p>Before entering the robot working area.</p>	
2	<p>Check that there are no obstacles inside the frame, that could prevent the balancing device from moving freely.</p> <p>Keep the areas around the balancing device clean and free from objects, such as service tools.</p>	 <p>xx1300000423</p>

3.3.9 Inspecting the cable harness

Location of cable harness

The cable harness is located as shown in the figure.

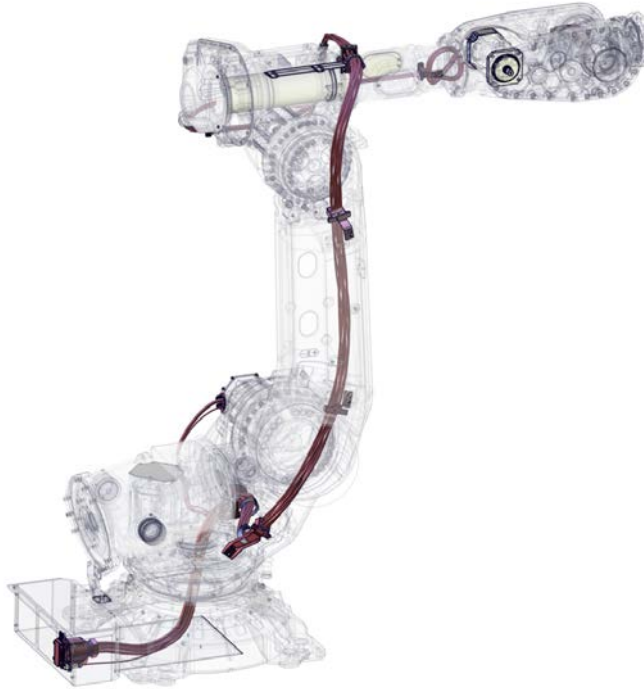

xx1300001096

Required tools

Visual inspection, no tools are needed.

Inspecting the cable harness

Use this procedure to inspect cable harness of axes 1-6.

	Action	Note
1	 DANGER Turn off all: <ul style="list-style-type: none"> • electric power supply • hydraulic pressure supply • air pressure supply to the robot, before entering the robot working area.	

Continues on next page

3 Maintenance

3.3.9 Inspecting the cable harness

Continued

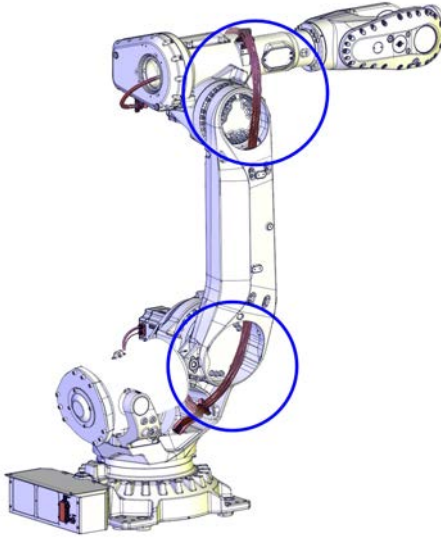
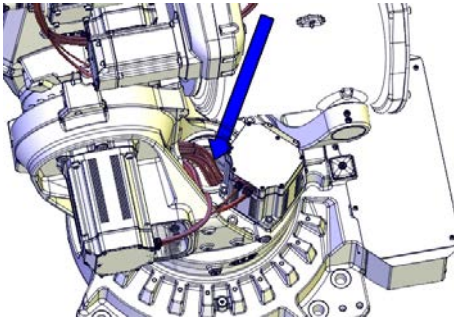
	Action	Note
2	<p>Make an overall inspection of the cable harness in order to detect wear and damage.</p> <p>Pay special attention to the areas of axis-2 and axis-3 movement, shown in the figure. Make sure the cabling is not damaged between the cable brackets in these areas.</p>	 <p>xx1300001095</p>
3	<p>Check that all visible cable brackets, velcro straps and attachments are properly secured, by following the cable harness from the base to the wrist.</p>	
4	<p>Check the motor cables visually for any damage.</p>	
5	<p>Check the connectors at the base visually for any damage.</p>	
6	<p>Check the cabling going through the protection tube, to detect possible cable chafing, by using your hands inside the tube to feel the cables. Ensure that the cables are undamaged.</p> <p>Remove any objects that may cause possible cable chafing.</p> <p>Replace damaged cabling, if any.</p>	 <p>xx1300001094</p>
7	<p>Replace the cable harness if wear, cracks or damage is detected.</p>	<p>See Removing the cable harness on page 219.</p>

3.3.10 Inspecting the information labels

Location of labels

These figures show the location of the information labels to be inspected. The symbols are described in section [Safety symbols on manipulator labels on page 23](#).

Illustration 1

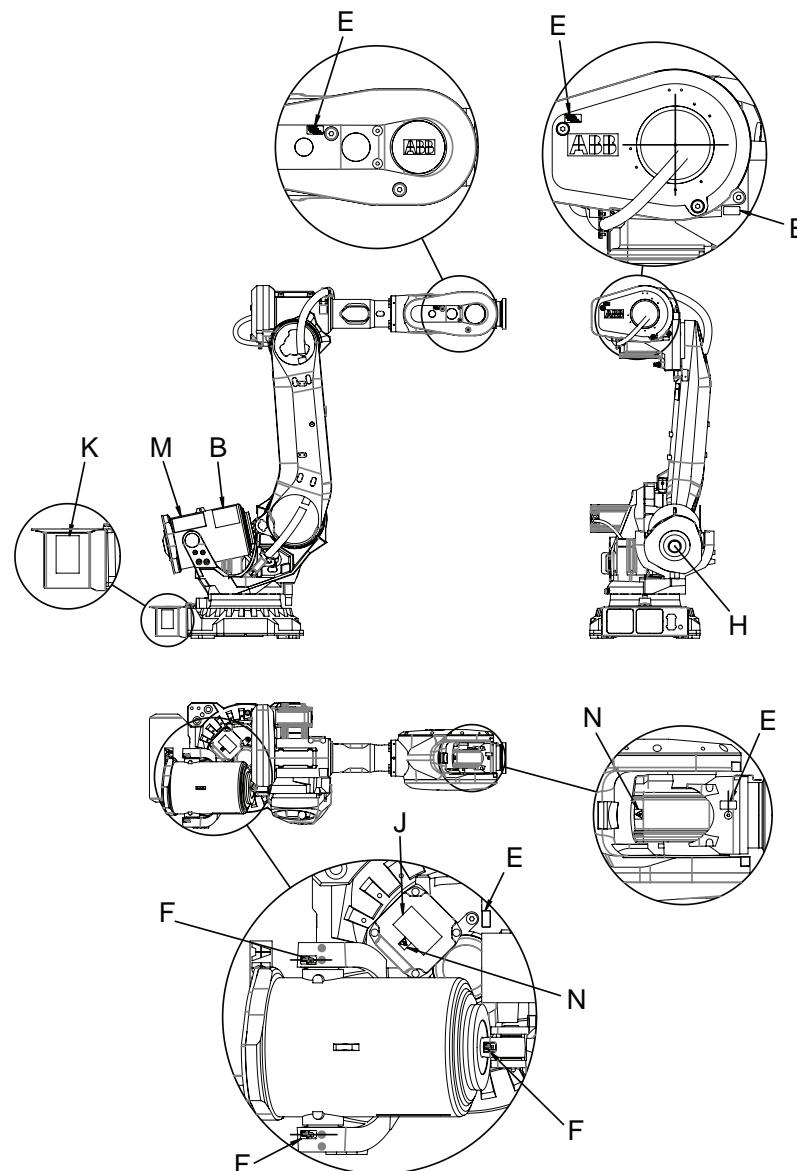

Continues on next page

3 Maintenance

3.3.10 Inspecting the information labels

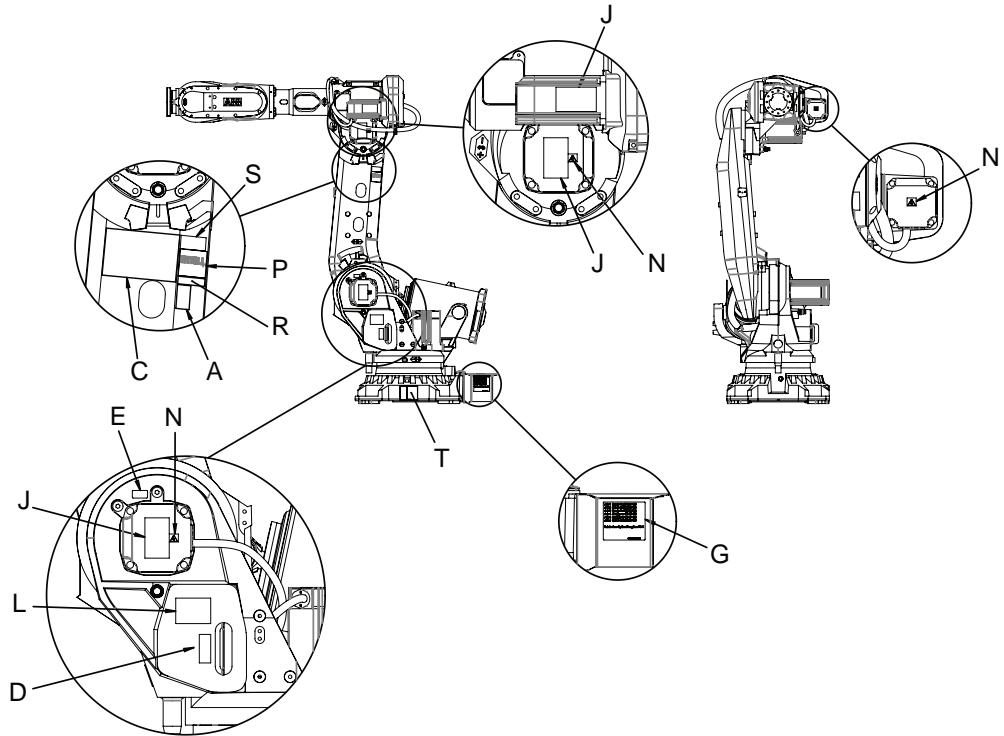

Continued

Illustration 2

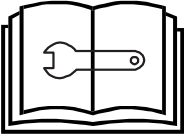
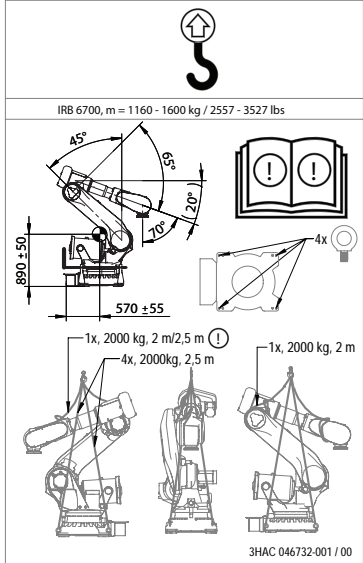

	Description	Illustration
A	Calibration label	
B	Instruction label Before dismantling see product manual	 xx0900000816
C	Instruction label Lifting of robot	 IRB 6700, m = 1160 - 1600 kg / 2557 - 3527 lbs 3HAC 046732-001 / 00 xx1300001084

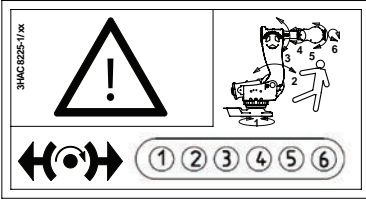
Continues on next page

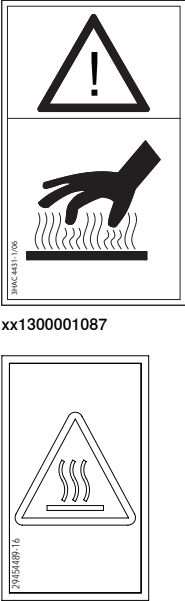
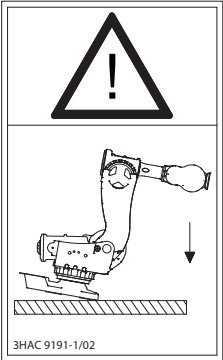
D	<p>Instruction label Brake release Moving robot Brake release buttons</p>	 <p>xx1300001083</p>
E	Oil specification label	
F	Grease specification label	
G	Complete oil specification	
H	<p>Warning label Do not dismantle Stored energy</p>	 <p>xx1300001086</p>
J	<p>Warning label Heat</p>	 <p>xx1300001087</p> <p>xx1700000984</p>
K	<p>Warning label Tip risk when loosening bolts</p>	 <p>xx1300001088</p>

Continues on next page

3 Maintenance

3.3.10 Inspecting the information labels

Continued

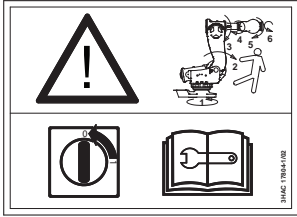
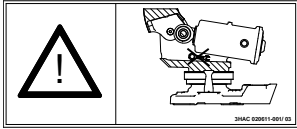
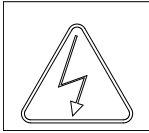
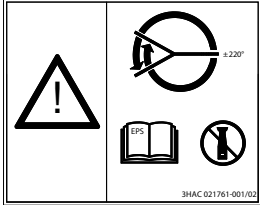
L	Warning label Moving robot Shut off with handle Before dismantling see product manual	 xx1300001089
M	Warning label Keep areas around the balancing device free from objects	 xx1300001090
N	Warning label Flash	 xx1300001091
P	Rating label	
R	Absolute accuracy label	
S	UL label	
T	Label Extended rotation No mechanical stop See user documentation	 xx1300001092

Required tools and equipment

Visual inspection, no tools are required.

Inspecting, labels

	Action	Note
1	 DANGER Turn off all: <ul style="list-style-type: none"> • electric power supply • hydraulic pressure supply • air pressure supply to the robot, before entering the safeguarded space.	
2	Inspect the labels, located as shown in the figures.	
3	Replace any missing or damaged labels.	Article numbers for the labels and plate set is specified in Spare parts on page 821 .

3.3.11 Inspecting the axis-1 mechanical stop pin



WARNING

Mechanical stop pin can not be fitted onto robot if option 561-1 *Extended work range axis 1* is used.

Location of mechanical stop pin

The axis-1 mechanical stop is located as shown in the figure.

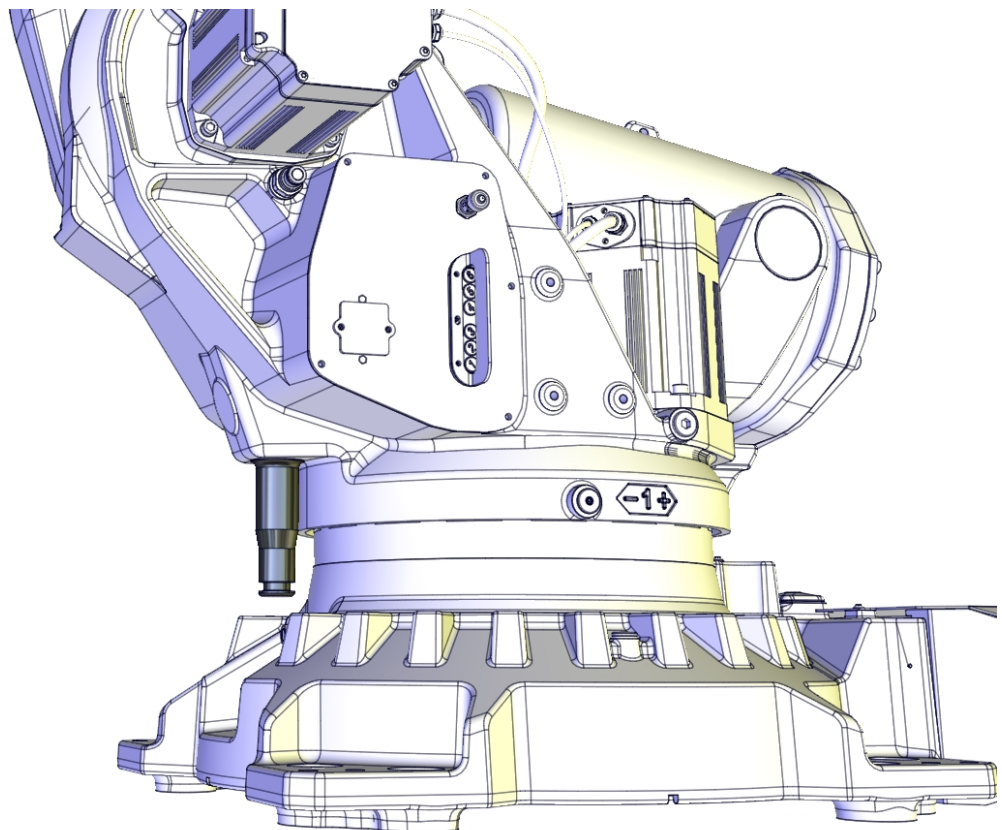

xx1200001073

Required equipment

Visual inspection, no tools are required.

Continues on next page



3 Maintenance

3.3.11 Inspecting the axis-1 mechanical stop pin

Continued

Inspecting, mechanical stop pin

Use this procedure to inspect the axis-1 mechanical stop pin.

	Action	Note
1	 DANGER Turn off all: <ul style="list-style-type: none">• electric power supply• hydraulic pressure supply• air pressure supply to the robot, before entering the safeguarded space.	
2	Inspect the axis-1 mechanical stop pin. If the mechanical stop pin is bent or damaged, it must be replaced.  Note The expected life of gearboxes can be reduced after collision with the mechanical stop.	

3.3.12 Inspecting the additional mechanical stops

Location of mechanical stops

The figure shows the location of additional mechanical stops.

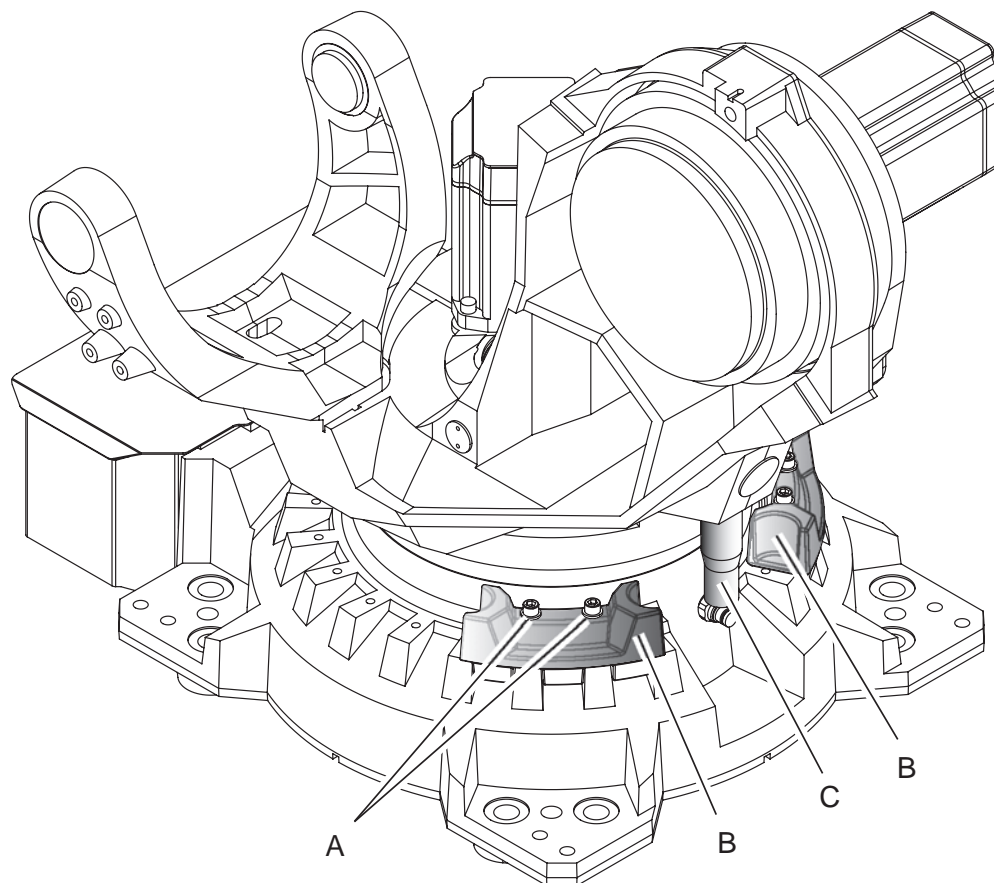

xx1300001971

A	Attachment screws M12x70 quality 12.9 Gleitmo 603 (2 pcs per additional mechanical stop)
B	Movable mechanical stop
C	Mechanical stop pin axis-1

Required equipment

Equipment etc.	Article number	Note
Movable mechanical stop axis 1	3HAC055744-001	IRB6700 235/2.65, 205/2.80, 175/3.05, 150/3.20, 200/2.60, 155/2.85 Limits the robot working range by 15°. Includes attachment screws and an assembly drawing. <ul style="list-style-type: none"> • Mechanical stop • Attachment screws M12x70 quality 12.9 Gleitmo 603 and washers • Document for mechanical stop

Continues on next page

3 Maintenance

3.3.12 Inspecting the additional mechanical stops

Continued

Equipment etc.	Article number	Note
Movable mechanical stop axis 1	3HAC048533-003	IRB6700 300/2.70, 245/3.00 Limits the robot working range by 15°. Includes attachment screws and an assembly drawing. <ul style="list-style-type: none"> • Mechanical stop • Attachment screws M12x70 stainless steel and washers stainless steel • Document for mechanical stop
Standard toolkit	-	Content is defined in section Standard toolkit on page 814 .

Inspecting, mechanical stops

Use this procedure to inspect the additional mechanical stops.

	Action	Note
1	 DANGER Turn off all: <ul style="list-style-type: none"> • electric power supply • hydraulic pressure supply • air pressure supply to the robot, before entering the robot working area.	
2	Make sure no additional stops are damaged.	Shown in figure Location of mechanical stops on page 139 .
3	Make sure the stops are properly attached. Correct tightening torque, additional mechanical stops: <ul style="list-style-type: none"> • Axis 1 = 60 Nm. 	
4	If any damage is detected, the mechanical stops must be replaced. Correct attachment screws: <ul style="list-style-type: none"> • M12x70 quality 12.9 Gleitmo 603 (2 pcs per additional mechanical stop) 	Article number is specified in Required equipment on page 139 .

3.3.13 Inspecting the dampers

Location of dampers

The figure below shows the location of all the dampers to be inspected.

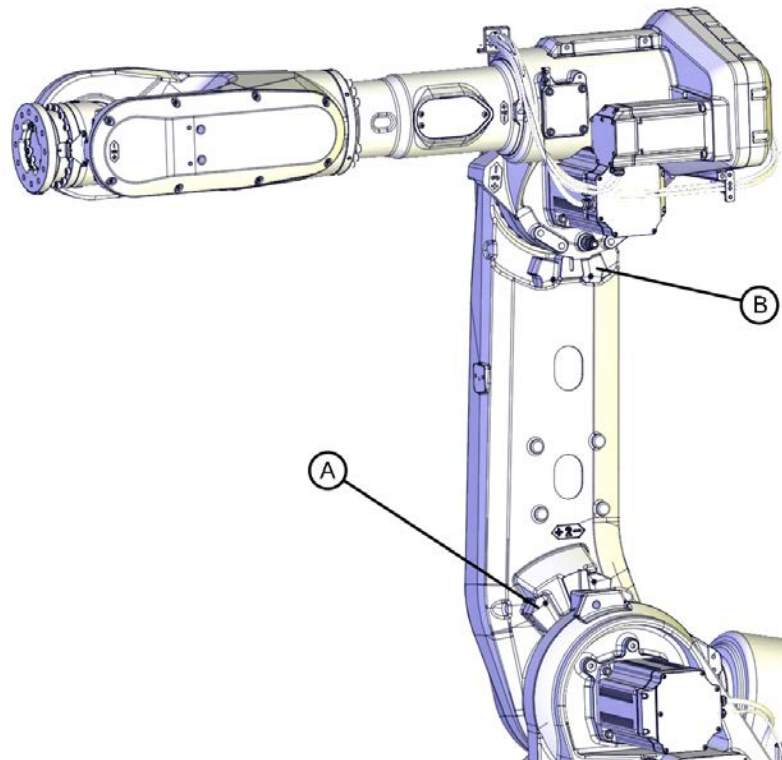

A	Axis-2 damper, 2 pcs
B	Axis-3 damper, 2 pcs

Required equipment

Visual inspection, no tools are required.

Inspecting, dampers

The procedure below details how to inspect the dampers.



Note

A damaged damper must be replaced.

	Action	Note
1	 <p>DANGER</p> <p>Turn off all:</p> <ul style="list-style-type: none"> • electric power supply to the robot • hydraulic pressure supply to the robot • air pressure supply to the robot <p>Before entering the robot working area.</p>	

Continues on next page

3 Maintenance

3.3.13 Inspecting the dampers

Continued

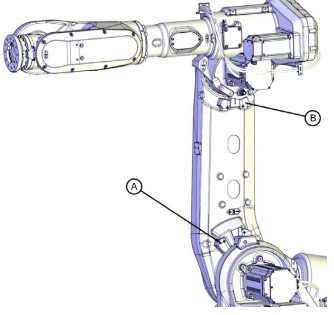
	Action	Note				
2	Check all dampers for damage, cracks or existing impressions larger than 1 mm.	 <table border="1" data-bbox="997 645 1406 739"> <tr> <td data-bbox="997 645 1038 689">A</td> <td data-bbox="1038 645 1406 689">Axis-2 damper, 2 pcs</td> </tr> <tr> <td data-bbox="997 689 1038 739">B</td> <td data-bbox="1038 689 1406 739">Axis-3 damper, 2 pcs</td> </tr> </table>	A	Axis-2 damper, 2 pcs	B	Axis-3 damper, 2 pcs
A	Axis-2 damper, 2 pcs					
B	Axis-3 damper, 2 pcs					
3	Check attachment screws for deformation.	<p data-bbox="416 763 991 824">4 If any damage is detected, the damper must be replaced with a new one. Attachment screws: M6x60. Locking liquid: Loctite 243.</p> <p data-bbox="991 763 1412 846">Spare part number is found in <i>Product manual, spare parts - IRB 6700/IRB 6700Inv.</i></p>				

3.3.14 Inspecting the signal lamp (option)

Location of signal lamp

The signal lamp is located as shown in this figure.

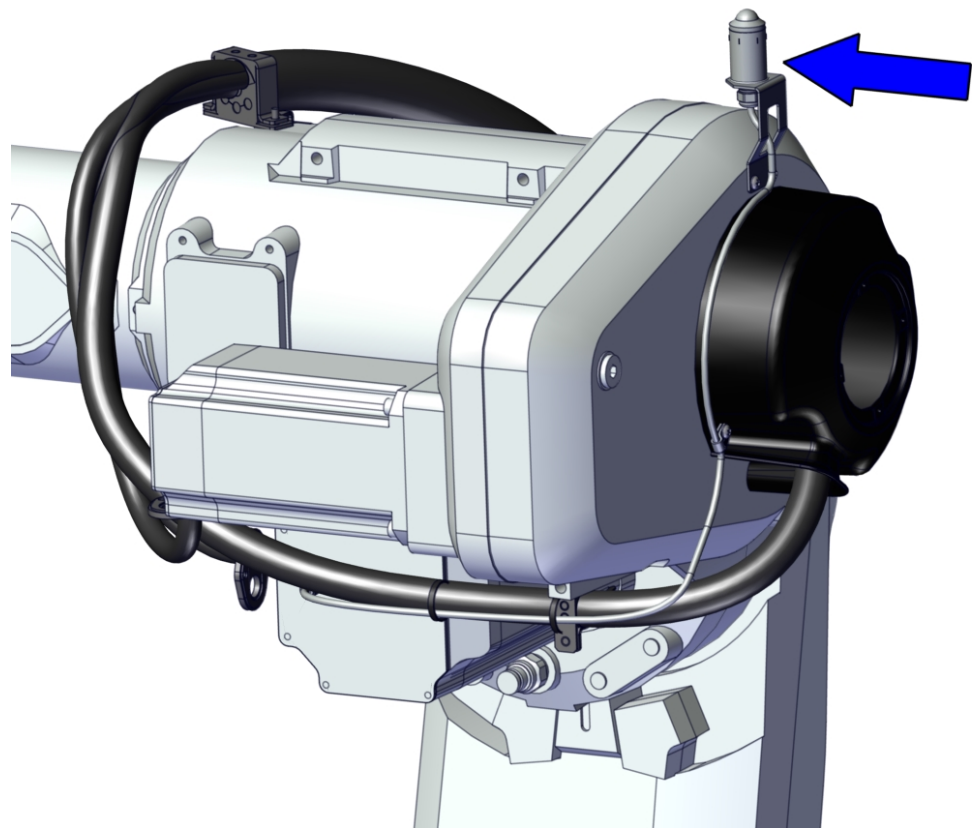

xx1600002089

Required tools and equipment

Equipment	Article number	Note
Signal lamp kit	See Spare parts on page 821 .	To be replaced if damage is detected.
Standard toolkit	-	Content is defined in section Standard toolkit on page 814 .

Inspecting, signal lamp

Use this procedure to inspect the function of the signal lamp.

	Action	Note
1	Inspect that signal lamp is lit when motors are put in operation ("MOTORS ON").	

Continues on next page

3 Maintenance

3.3.14 Inspecting the signal lamp (option)

Continued

	Action	Note
2	 DANGER Turn off all: <ul style="list-style-type: none">• electric power supply• hydraulic pressure supply• air pressure supply to the robot, before entering the safeguarded space.	
3	If the lamp is not lit, trace the fault by: <ul style="list-style-type: none">• inspecting whether the signal lamp is broken. If so, replace it.• inspecting cable connections.• measuring the voltage in the connectors of motor axis 3 (=24V).• inspecting the cabling. Replace the cabling if a fault is detected.	Article number is specified in Required tools and equipment on page 143 .

3.4 Replacement/changing activities

3.4.1 Type of lubrication in gearboxes

Introduction

This section describes where to find information about the type of lubrication, article number and the amount of lubrication in the specific gearbox. It also describes the equipment needed when working with lubrication.

Type and amount of oil in gearboxes

Information about the type of lubrication, article number as well as the amount in the specific gearbox can be found in *Technical reference manual - Lubrication in gearboxes* available for registered users on myABB Business Portal, www.abb.com/myABB.

Location of gearboxes

The figure shows the location of the gearboxes.

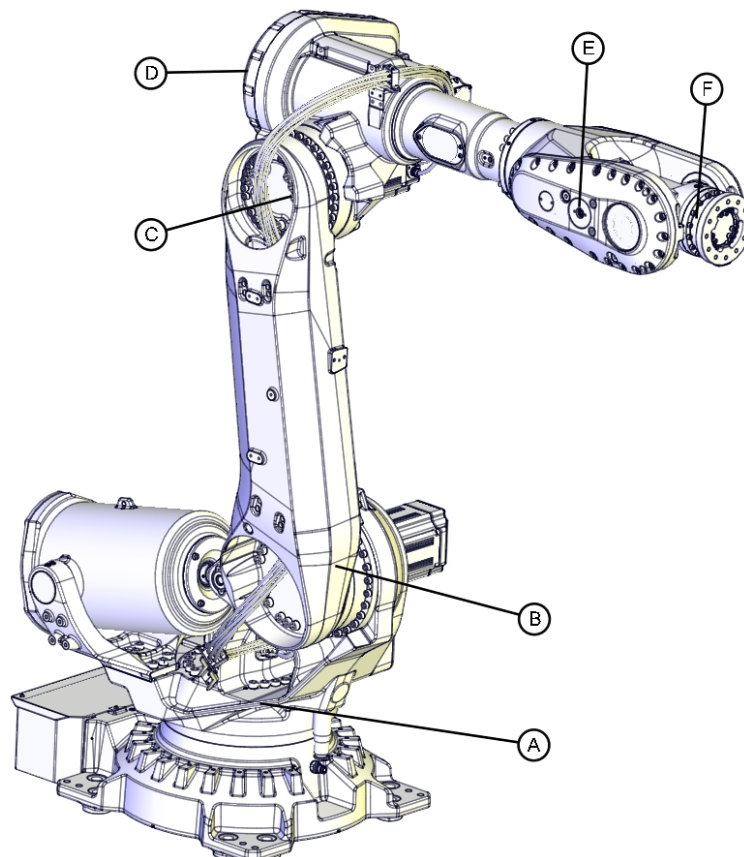

xx140000189

A	Gearbox, axis 1
---	-----------------

Continues on next page

3 Maintenance

3.4.1 Type of lubrication in gearboxes

Continued

B	Gearbox, axis 2
C	Gearbox, axis 3
D	Gearbox, axis 4
E	Gearbox, axis 5
F	Gearbox, axis 6

Equipment

Equipment	Note
Oil dispenser	Includes pump with outlet pipe. Use the suggested dispenser or a similar one: <ul style="list-style-type: none">• Orion OriCan article number 22590 (pneumatic)
Nipple for quick connect fitting, with o-ring	

3.4.2 Changing oil, axis-1 gearbox

Usage of oil dispenser

The oil change procedure in this section describes usage of an oil dispenser.

Location of oil plugs

The oil plugs of the gearbox are located as shown in the figure.

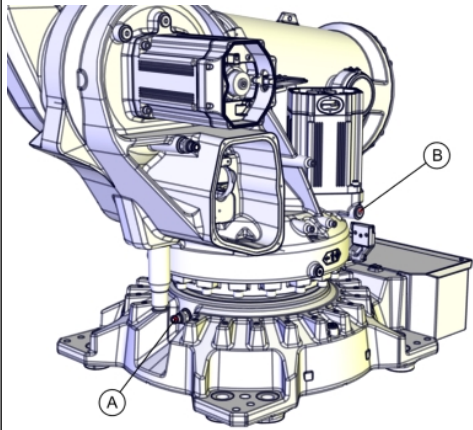
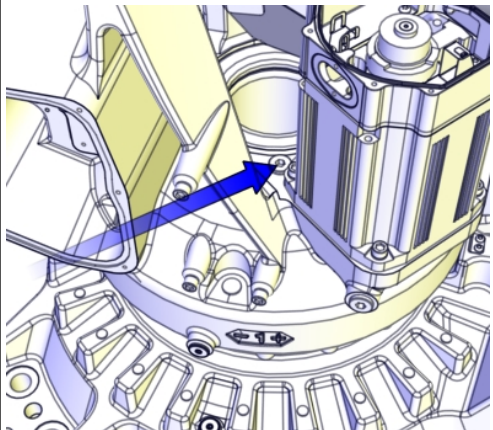
 <p>xx1500001654</p>	 <p>xx1500001644</p>
<p>A Oil hole with nipple (Used for both draining and filling with an oil dispenser).</p> <p>B Level plug (300/2.70, 245/3.00)</p>	<p>Oil plug.</p> <p>Used for both ventilation and level measurement on manipulator types:</p> <ul style="list-style-type: none"> • IRB 6700 - 235/2.65, IRB 6700 - 205/2.80, IRB 6700 - 175/3.05, IRB 6700 - 150/3.20 • IRB 6700 - 200/2.60, IRB 6700 - 155/2.85 <p>Used for ventilation on manipulator types:</p> <ul style="list-style-type: none"> • IRB 6700 - 300/2.70, IRB 6700 - 245/3.00
<p>Tightening torque: 24 Nm.</p>	<p>Tightening torque: 24 Nm.</p>

Consumables

Material	Note
Lubricating oil	Information about the oil is found in <i>Technical reference manual - Lubrication in gearboxes</i> . See Type and amount of oil in gearboxes on page 145 .

Required tools and equipment

Equipment, etc.	Article number	Note
Oil collecting vessel	-	The capacity of the vessel must be sufficient to take the complete amount of oil.
Oil dispenser	-	One example of oil dispenser can be found in section Type of lubrication in gearboxes on page 145 .

Continues on next page

3 Maintenance

3.4.2 Changing oil, axis-1 gearbox

Continued



Equipment, etc.	Article number	Note
Standard toolkit	-	Content is defined in section Standard toolkit on page 814 .

Required documents





Document name	Document number	Note
<i>Technical reference manual - Lubrication in gearboxes</i>	3HAC042927-001	

Draining the axis-1 gearbox

Use this procedure to drain the gearbox.

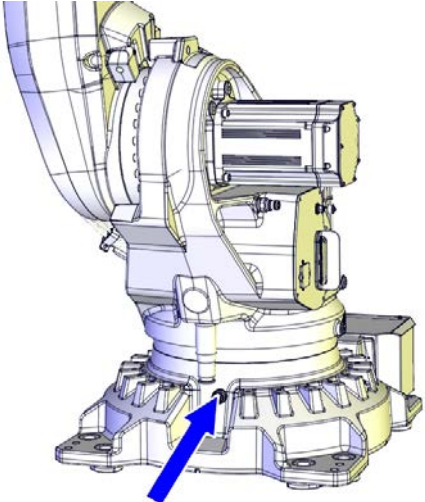
	Action	Note
1	 DANGER Turn off all: <ul style="list-style-type: none">• electric power supply• hydraulic pressure supply• air pressure supply to the robot, before entering the safeguarded space.	
2	 WARNING Handling gearbox oil involves several safety risks, see Gearbox lubricants (oil or grease) on page 34 .	
3	 CAUTION The gearbox can contain an <i>excess of pressure</i> that can be hazardous. Open the oil plug carefully in order to let the excess pressure out.	

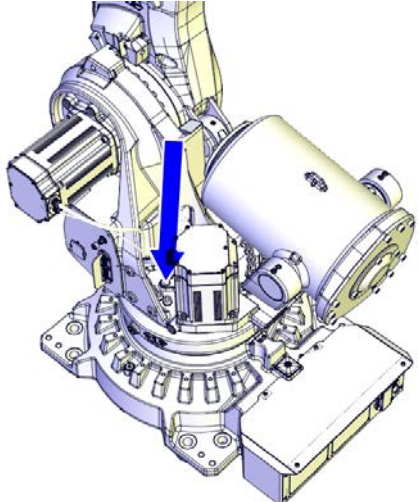
Continues on next page

	Action	Note
4	Remove the protective cap from the nipple of the oil hole and connect the oil dispenser.	 <p>xx120000948</p>
5	Remove the plug from the vent hole.  WARNING Open the vent hole while using the dispenser, to avoid damaging vital parts in the gear.	 <p>xx120000950</p>
6	Suck out the oil with the oil dispenser.  Note There will be some oil left in the gear after draining.	
7	 WARNING Used oil is hazardous material and must be disposed of in a safe way. See section Decommissioning on page 799 for more information.	
8	Remove the oil dispenser. Refit the protective cap on the nipple.	
9	Refit the vent hole plug.	Tightening torque: 24 Nm.

Continues on next page





3 Maintenance

3.4.2 Changing oil, axis-1 gearbox

Continued

Filling oil into the axis-1 gearbox

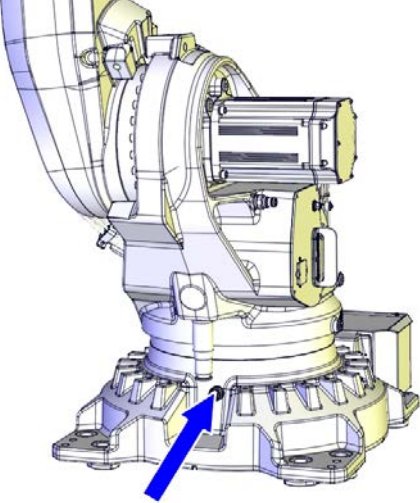
Use this procedure to refill the gearbox with oil.

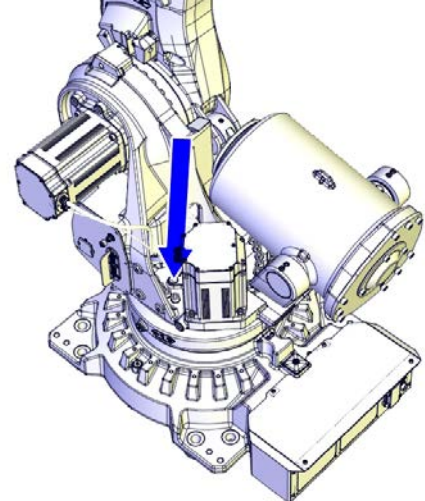
	Action	Note
1	<p> DANGER</p> <p>Turn off all:</p> <ul style="list-style-type: none"> • electric power supply • hydraulic pressure supply • air pressure supply <p>to the robot, before entering the safe-guarded space.</p>	
2	<p> WARNING</p> <p>Handling gearbox oil involves several safety risks, see Gearbox lubricants (oil or grease) on page 34.</p>	
3	<p>Remove the protective cap from the nipple of the oil hole and connect the oil dispenser.</p>	 <p>xx120000948</p>
4	<p>Remove the plug from the vent hole.</p> <p> Note</p> <p>The vent hole is opened to let out air during the filling process.</p>	 <p>xx120000950</p>

Continues on next page

	Action	Note
5	<p>Refill the gearbox with oil with the oil dispenser.</p> <p> Note</p> <p>The amount of oil to be filled depends on the amount previously being drained.</p>	<p>Type of oil and total amount is detailed in <i>Technical reference manual - Lubrication in gearboxes</i>.</p>



3 Maintenance

3.4.2 Changing oil, axis-1 gearbox

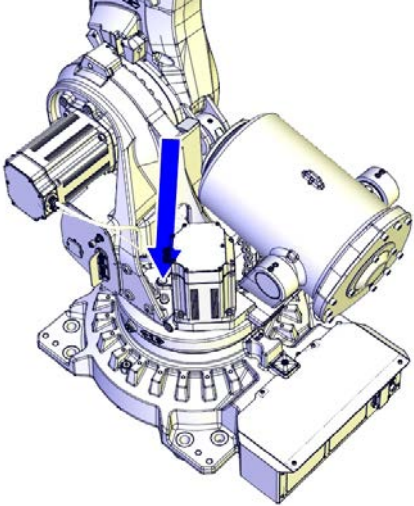
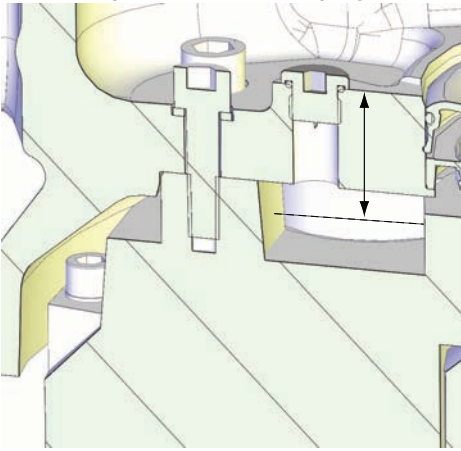
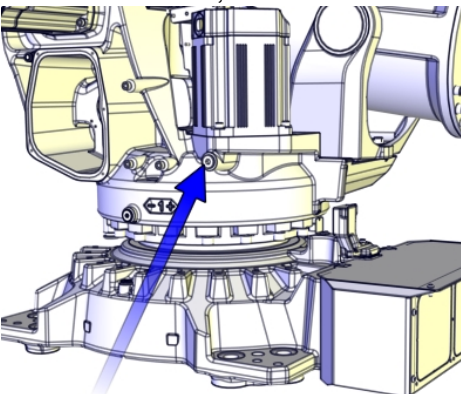
Continued

	Action	Note
6	Inspect the oil level.	<p>IRB 6700 - 235/2.65, IRB 6700 - 205/2.80, IRB 6700 - 175/3.05, IRB 6700 - 150/3.20 IRB 6700 - 200/2.60, IRB 6700 - 155/2.85</p>  <p>xx1200000950</p> <p>Required oil level: 58 mm ± 5 mm below the sealing surface of the oil plug.</p>  <p>xx1300000692</p> <p>IRB 6700 - 300/2.70, IRB 6700 - 245/3.00</p>  <p>xx1500001655</p>

Continues on next page

	Action	Note
		Required oil level: 0 - 10 mm below the oil plug hole.
7	Remove the oil dispenser and refit the protective cap to the nipple.	
8	Refit the vent hole plug.	Tightening torque: 24 Nm
9	 Note After all repair and maintenance work involving oil, always wipe the robot clean from all surplus oil. The robot color can otherwise be discolored.	
10	 DANGER Make sure all safety requirements are met when performing the first test run.	

3 Maintenance

3.4.3 Changing oil, axis-2 gearbox

3.4.3 Changing oil, axis-2 gearbox

Usage of oil dispenser

The oil change procedure in this section describes usage of an oil dispenser.

Location of oil plugs

The oil plugs of the gearbox are located as shown in the figure.

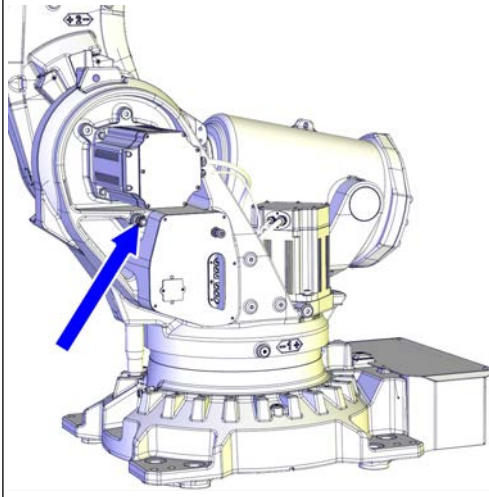
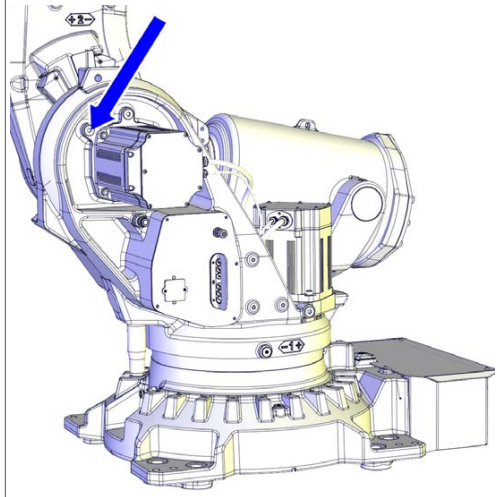
 <p>xx1200000951</p>	 <p>xx1200000952</p>
<p>Oil hole with nipple Used for both draining and filling with an oil dispenser.</p>	<p>Vent hole plug/level plug</p>
<p>Tightening torque: N/A.</p>	<p>Tightening torque: 24 Nm.</p>

Required tools and equipment

Equipment, etc.	Article number	Note
Oil collecting vessel	-	The capacity of the vessel must be sufficient to take the complete amount of oil.
Oil dispenser	-	One example of oil dispenser can be found in section Type of lubrication in gearboxes on page 145 .
Standard toolkit	-	Content is defined in section Standard toolkit on page 814 .

Consumable

Material	Note
Lubricating oil	Information about the oil is found in <i>Technical reference manual - Lubrication in gearboxes</i> . See Type and amount of oil in gearboxes on page 145 .



Continues on next page

Required documents

Document name	Document number	Note
Technical reference manual - Lubrication in gearboxes	3HAC042927-001	

Draining the axis-2 gearbox

Use this procedure to drain the gearbox.

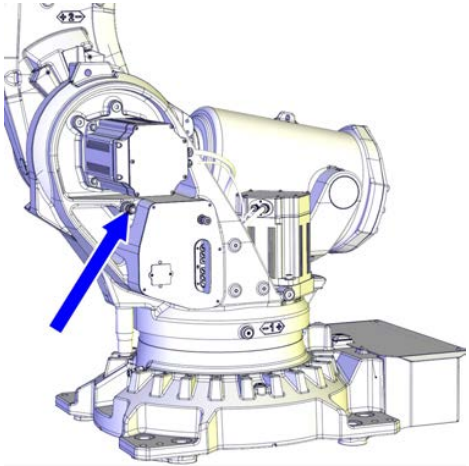

	Action	Note
1	 DANGER Turn off all: <ul style="list-style-type: none"> • electric power supply • hydraulic pressure supply • air pressure supply to the robot, before entering the safeguarded space.	
2	 WARNING Handling gearbox oil involves several safety risks, see Gearbox lubricants (oil or grease) on page 34 .	
3	 CAUTION The gearbox can contain an <i>excess pressure</i> that can be hazardous. Open the oil plug carefully in order to let the excess pressure out.	
4	Remove the protective cap from the nipple of the oil hole and connect the oil dispenser.	 <p>xx120000951</p>

Continues on next page

3 Maintenance

3.4.3 Changing oil, axis-2 gearbox

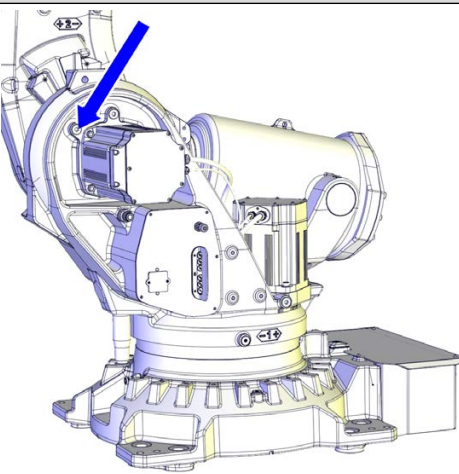
Continued





	Action	Note
5	<p>Remove the plug from the vent hole.</p> <p> WARNING</p> <p>Open the vent hole while using the dispenser, to avoid damaging vital parts in the gear.</p>	 <p>xx120000952</p>
6	<p>Suck out the oil with the oil dispenser.</p> <p> Note</p> <p>There will be some oil left in the gear after draining.</p>	
7	<p> WARNING</p> <p>Used oil is hazardous material and must be disposed of in a safe way. See section Decommissioning on page 799 for more information.</p>	
8	<p>Refill oil or:</p> <ol style="list-style-type: none"> 1 Remove the oil dispenser 2 Refit the protective cap on the nipple. 3 Refit the vent hole plug. 	<p>Vent hole plug, tightening torque: 24 Nm.</p>

Filling oil into the axis-2 gearbox

Use this procedure to refill the gearbox with oil.

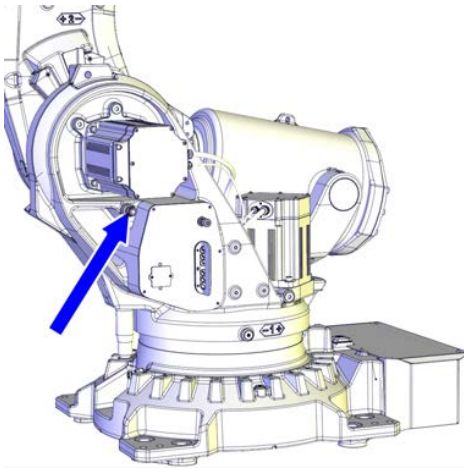
	Action	Note
1	<p> DANGER</p> <p>Turn off all:</p> <ul style="list-style-type: none"> • electric power supply • hydraulic pressure supply • air pressure supply <p>to the robot, before entering the safe-guarded space.</p>	

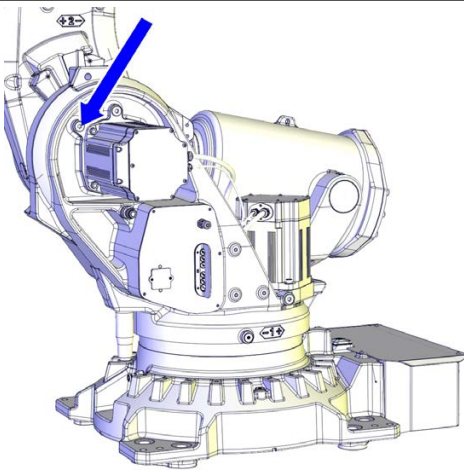
Continues on next page



	Action	Note
2	<p> WARNING</p> <p>Handling gearbox oil involves several safety risks, see Gearbox lubricants (oil or grease) on page 34.</p>	
3	<p>Remove the protective cap from the nipple of the oil hole and connect the oil dispenser.</p>	 <p>xx120000951</p>
4	<p>Remove the plug from the vent hole.</p> <p> Note</p> <p>The vent hole is opened to let air out during the filling process.</p>	 <p>xx120000952</p>
5	<p>Refill the gearbox with oil.</p> <p> Note</p> <p>The amount of oil to be filled depends on the amount previously being drained.</p>	<p>Type of oil and total amount is detailed in <i>Technical reference manual - Lubrication in gearboxes</i>.</p>

Continues on next page

3 Maintenance

3.4.3 Changing oil, axis-2 gearbox

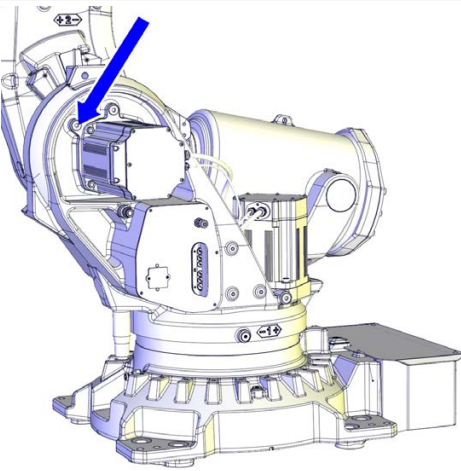
Continued

	Action	Note
6	Inspect the oil level at the vent hole (level plug).	 <p data-bbox="943 779 1050 801">xx120000952</p> <p data-bbox="943 815 1406 875">Required oil level is: 0-15 mm below the oil plug hole.</p> <p data-bbox="943 880 1406 936">More information is found in Inspecting the oil level in axis-2 gearbox on page 116.</p>
7	Remove the oil dispenser. Refit the protective cap on the nipple.	
8	Refit the level plug.	Tightening torque: 24 Nm
9	 DANGER Make sure all safety requirements are met when performing the first test run.	

3.4.4 Changing oil, axis-3 gearbox

Usage of oil dispenser

The oil change procedure in this section describes usage of an oil dispenser.

Location of oil plugs

The oil plugs of the gearbox are located as shown in the figure.

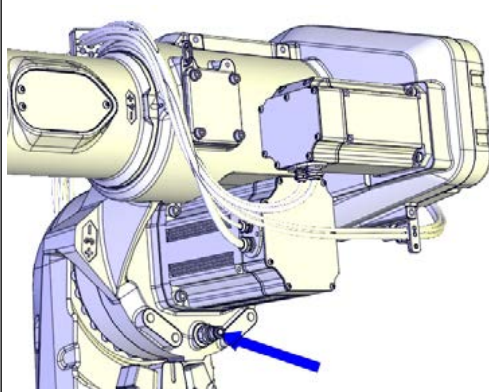
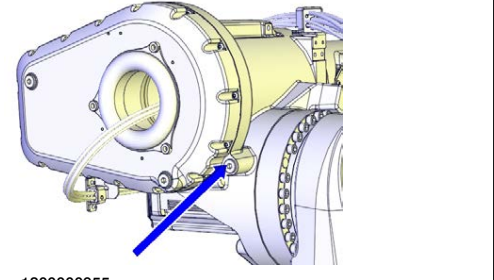
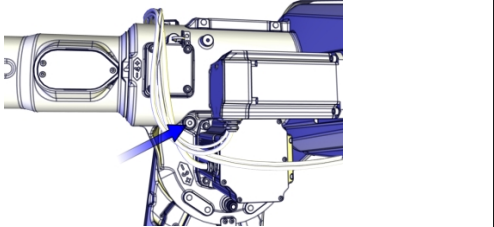
	<p>IRB 6700 - 235/2.65, IRB 6700 - 205/2.80, IRB 6700 - 175/3.05, IRB 6700 - 150/3.20, IRB 6700 - 200/2.60, IRB 6700 - 155/2.85</p>
<p>xx1200000954</p>	
	<p>xx1200000955</p>
	<p>IRB 6700 - 300/2.70, IRB 6700 - 245/3.00</p>
	
	<p>xx1500001645</p>
<p>Oil hole with nipple Used for both draining and filling with an oil dispenser.</p>	<p>Level/vent plug</p>
<p>Tightening torque: 24 Nm.</p>	<p>Tightening torque: 24 Nm.</p>

Required tools and equipment

Equipment, etc.	Article number	Note
Oil collecting vessel	-	The capacity of the vessel must be sufficient to take the complete amount of oil.
Oil dispenser	-	One example of oil dispenser can be found in section Type of lubrication in gearboxes on page 145 .
Standard toolkit	-	Content is defined in section Standard toolkit on page 814 .

Continues on next page

3 Maintenance

3.4.4 Changing oil, axis-3 gearbox

Continued

Consumable



Material	Note
Lubricating oil	Information about the oil is found in <i>Technical reference manual - Lubrication in gearboxes</i> . See Type and amount of oil in gearboxes on page 145 .

Required documents



Document name	Document number	Note
<i>Technical reference manual - Lubrication in gearboxes</i>	3HAC042927-001	

Draining the axis-3 gearbox

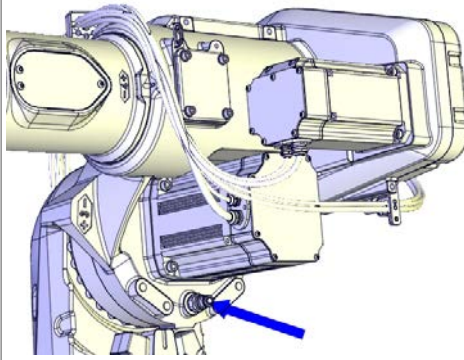
Use this procedure to drain the gearbox.

	Action	Note
1	Run the robot to calibration position.	
2	 DANGER Turn off all: <ul style="list-style-type: none"> • electric power supply • hydraulic pressure supply • air pressure supply to the robot, before entering the safeguarded space.	
3	 WARNING Handling gearbox oil involves several safety risks, see Gearbox lubricants (oil or grease) on page 34 .	
4	 CAUTION The gearbox can contain an <i>excess pressure</i> that can be hazardous. Open the oil plug carefully in order to let the excess pressure out.	
5	Remove the protective cap from the nipple of the oil hole and connect the oil dispenser.	 <p>xx120000954</p>

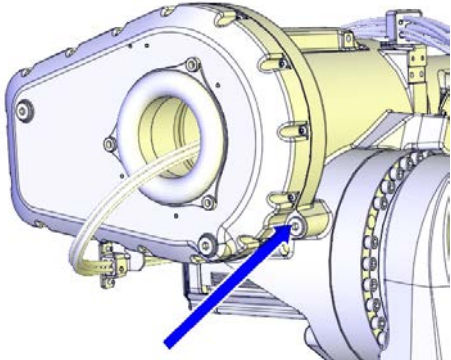
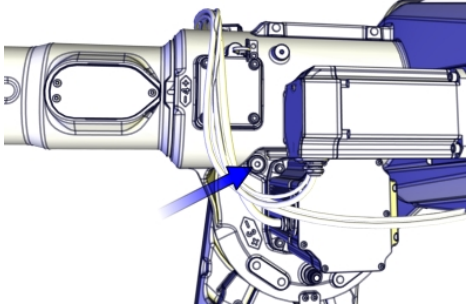
Continues on next page

	Action	Note
6	<p>Remove the plug from the vent hole.</p> <p> WARNING</p> <p>Open the vent hole while using the dispenser, to avoid damaging vital parts in the gear.</p>	 <p>xx120000955</p> <p>IRB 6700 - 235/2.65, IRB 6700 - 205/2.80, IRB 6700 - 175/3.05, IRB 6700 - 150/3.20, IRB 6700 - 200/2.60, IRB 6700 - 155/2.85</p>  <p>xx1500001645</p> <p>IRB 6700 - 300/2.70, IRB 6700 - 245/3.00</p>
7	<p>Suck out the oil with the oil dispenser.</p> <p> Note</p> <p>There will be some oil left in the gear after draining.</p>	
8	<p> WARNING</p> <p>Used oil is hazardous material and must be disposed of in a safe way. See Decommissioning on page 799 for more information.</p>	
9	<p>Remove the oil dispenser. Refit the protective cap on the nipple.</p>	
10	<p>Refit the vent hole plug.</p>	<p>Tightening torque: 24 Nm.</p>

Filling oil into the axis-3 gearbox

Use this procedure to refill the gearbox with oil.



	Action	Note
1	<p>Run the robot to calibration position.</p>	

Continues on next page



3 Maintenance

3.4.4 Changing oil, axis-3 gearbox

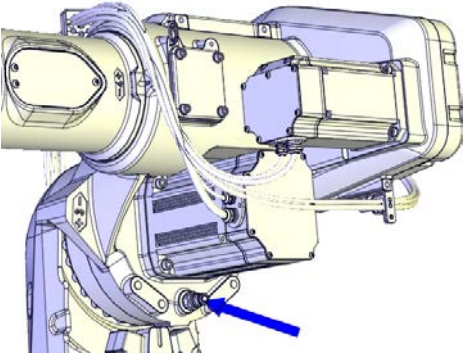
Continued

	Action	Note
2	<p> DANGER</p> <p>Turn off all:</p> <ul style="list-style-type: none">• electric power supply• hydraulic pressure supply• air pressure supply <p>to the robot, before entering the safe-guarded space.</p>	
3	<p> WARNING</p> <p>Handling gearbox oil involves several safety risks, see Gearbox lubricants (oil or grease) on page 34.</p>	
4	<p>Remove the protective cap from the nipple of the oil hole and connect the oil dispenser.</p>	 <p>xx120000954</p>

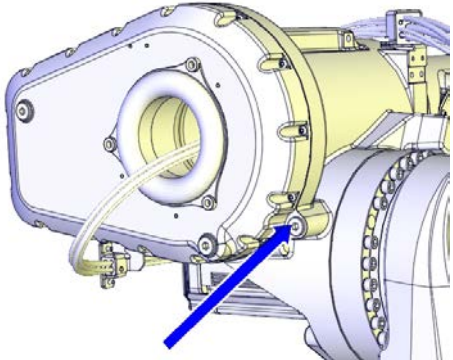
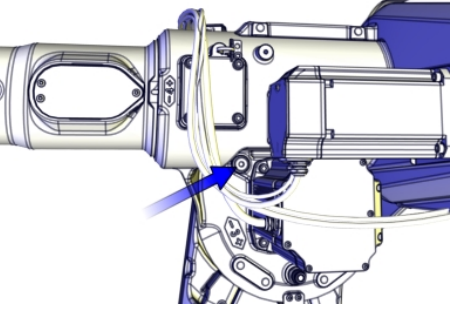
Continues on next page



	Action	Note
5	<p>Remove the plug from the vent hole.</p> <p> Note</p> <p>The vent hole is opened to let air out during the filling process.</p>	 <p>xx120000955</p> <p>IRB 6700 - 235/2.65, IRB 6700 - 205/2.80, IRB 6700 - 175/3.05, IRB 6700 - 150/3.20, IRB 6700 - 200/2.60, IRB 6700 - 155/2.85</p>  <p>xx1500001645</p> <p>IRB 6700 - 300/2.70, IRB 6700 - 245/3.00</p>
6	<p>Refill the gearbox with oil.</p> <p> Note</p> <p>The amount of oil to be filled depends on the amount previously being drained.</p>	<p>Type of oil and total amount is detailed in <i>Technical reference manual - Lubrication in gearboxes</i>.</p>

Continues on next page

3 Maintenance

3.4.4 Changing oil, axis-3 gearbox

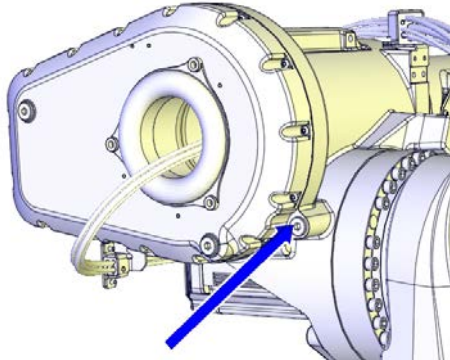
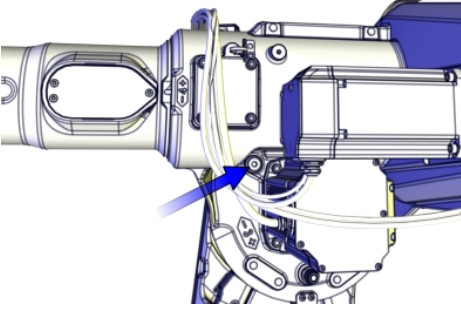
Continued

	Action	Note
7	Inspect the oil level at the vent hole (level plug).	 <p data-bbox="943 689 1050 707">xx120000955</p> <p data-bbox="943 725 1401 808">IRB 6700 - 235/2.65, IRB 6700 - 205/2.80, IRB 6700 - 175/3.05, IRB 6700 - 150/3.20, IRB 6700 - 200/2.60, IRB 6700 - 155/2.85</p>  <p data-bbox="943 1151 1050 1169">xx1500001645</p> <p data-bbox="943 1187 1401 1218">IRB 6700 - 300/2.70, IRB 6700 - 245/3.00</p> <p data-bbox="943 1223 1401 1274">Required oil level is: 0 - 20 mm below the oil plug hole.</p> <p data-bbox="943 1279 1406 1330">More information is found in Inspecting the oil level in axis-3 gearbox on page 118.</p>
8	Remove the oil dispenser. Refit the protective cap on the nipple.	
9	Refit the level plug.	Tightening torque: 24 Nm
10	 <p data-bbox="560 1509 667 1541">DANGER</p> <p data-bbox="464 1570 933 1621">Make sure all safety requirements are met when performing the first test run.</p>	

3.4.5 Changing oil, axis-4 gearbox

Location of oil plugs

The oil plugs of the gearbox are located as shown in the figure.

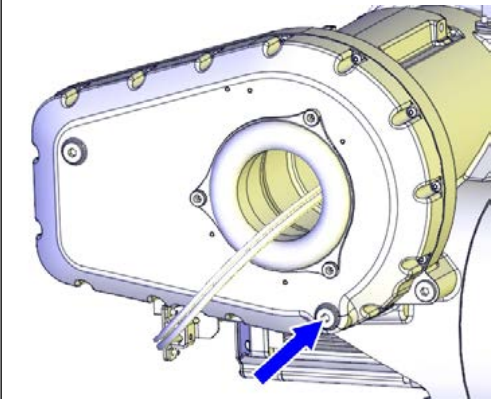
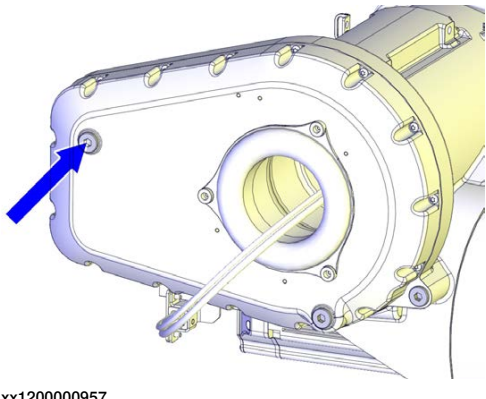
	
Oil drain plug	Oil fill plug/level plug
Tightening torque: 24 Nm.	Tightening torque: 24 Nm.

Required tools and equipment

Equipment, etc.	Article number	Note
Oil collecting vessel	-	The capacity of the vessel must be sufficient to take the complete amount of oil.
Oil dispenser	-	One example of oil dispenser can be found in section Type of lubrication in gearboxes on page 145 .
Standard toolkit	-	Content is defined in section Standard toolkit on page 814 .

Consumable

Material	Note
Lubricating oil	Information about the oil is found in <i>Technical reference manual - Lubrication in gearboxes</i> . See Type and amount of oil in gearboxes on page 145 .

Required documents

Document name	Document number	Note
<i>Technical reference manual - Lubrication in gearboxes</i>	3HAC042927-001	

Draining the axis-4 gearbox

Use this procedure to drain the gearbox.





	Action	Note
1	Run the robot to calibration position.	

Continues on next page

3 Maintenance

3.4.5 Changing oil, axis-4 gearbox

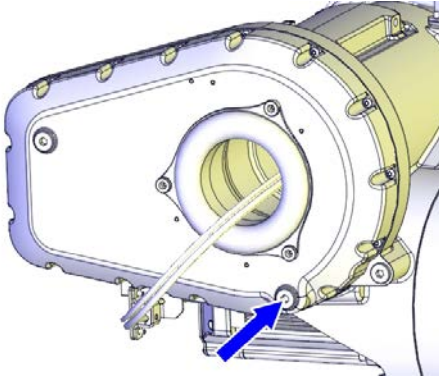
Continued

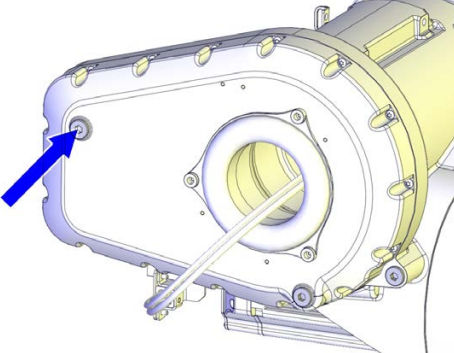



	Action	Note
2	<p> DANGER</p> <p>Turn off all:</p> <ul style="list-style-type: none"> • electric power supply • hydraulic pressure supply • air pressure supply <p>to the robot, before entering the safe-guarded space.</p>	
3	<p> WARNING</p> <p>Handling gearbox oil involves several safety risks, see Gearbox lubricants (oil or grease) on page 34.</p>	
4	<p> CAUTION</p> <p>The gearbox can contain an <i>excess pressure</i> that can be hazardous. Open the oil plug carefully in order to let the excess pressure out.</p>	
5	Place the oil collecting vessel underneath the oil drain plug.	
6	Remove the oil plug from the drain hole and let the oil run into the vessel.	 <p>xx1200000956</p>
7	<p>Remove the oil plug from the fill/level hole.</p> <p> Note</p> <p>The level hole is opened to speed up the drainage.</p>	 <p>xx1200000957</p>

Continues on next page

	Action	Note
8	 WARNING Used oil is hazardous material and must be disposed of in a safe way. See Decommissioning on page 799 for more information.	
9	Refill oil or refit the oil plugs.	Tightening torque: 24 Nm.

Filling oil into the axis-4 gearbox

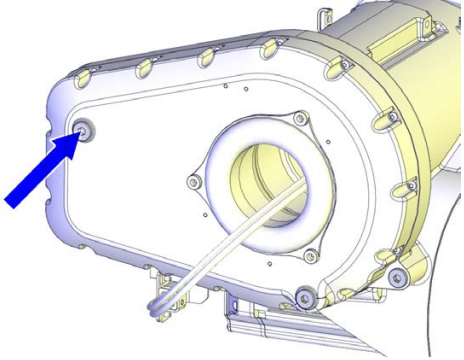
Use this procedure to refill the gearbox with oil.



	Action	Note
1	Run the robot to calibration position.	
2	 DANGER Turn off all: <ul style="list-style-type: none"> • electric power supply • hydraulic pressure supply • air pressure supply to the robot, before entering the safeguarded space.	
3	 WARNING Handling gearbox oil involves several safety risks, see Gearbox lubricants (oil or grease) on page 34 .	
4	Open the fill/level plug.	 <p style="text-align: right; font-size: small;">xx1200000957</p>
5	Refill the gearbox with oil.  Note The amount of oil to be filled depends on the amount previously being drained.	Type of oil and total amount is detailed in <i>Technical reference manual - Lubrication in gearboxes</i> .

Continues on next page

3 Maintenance

3.4.5 Changing oil, axis-4 gearbox

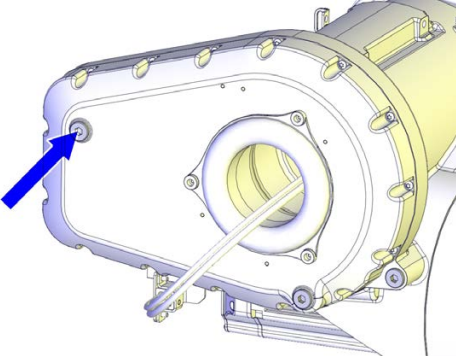
Continued

	Action	Note
6	Inspect the oil level.	<p>The level is measured at the fill hole.</p>  <p>xx120000957</p> <p>Required oil level is: 0 - 10 mm below the oil plug hole.</p> <p>See Inspecting the oil level in axis-4 gearbox on page 120.</p>
7	Refit the oil plug.	Tightening torque: 24 Nm
8	 DANGER Make sure all safety requirements are met when performing the first test run.	

3.4.6 Changing oil, axis-5 gearbox

Location of oil plugs

The oil plugs of the gearbox are located as shown in the figure.

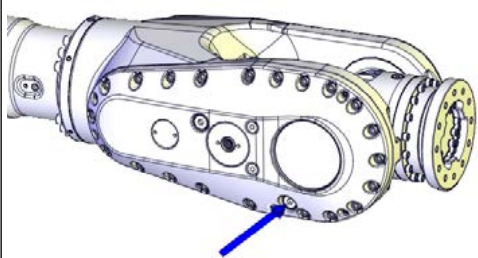
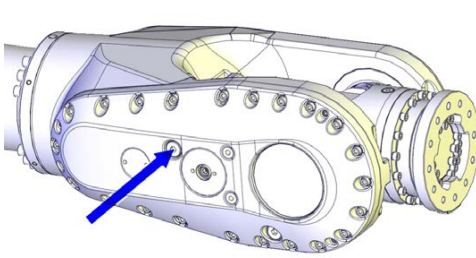
	
xx1200000958	xx1200000959
Oil drain plug	Oil fill plug/level plug
Tightening torque: 24 Nm.	Tightening torque: 24 Nm.

Required tools and equipment

Equipment, etc.	Article number	Note
Oil collecting vessel	-	The capacity of the vessel must be sufficient to take the complete amount of oil.
Oil dispenser	-	One example of oil dispenser can be found in section Type of lubrication in gearboxes on page 145 .
Standard toolkit	-	Content is defined in section Standard toolkit on page 814 .

Consumable

Material	Note
Lubricating oil	Information about the oil is found in <i>Technical reference manual - Lubrication in gearboxes</i> . See Type and amount of oil in gearboxes on page 145 .

Required documents

Document name	Document number	Note
<i>Technical reference manual - Lubrication in gearboxes</i>	3HAC042927-001	

Draining the axis-5 gearbox

Use this procedure to drain the gearbox.







	Action	Note
1	Run the robot to calibration position.	

Continues on next page

3 Maintenance

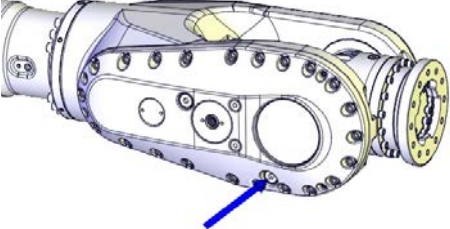
3.4.6 Changing oil, axis-5 gearbox

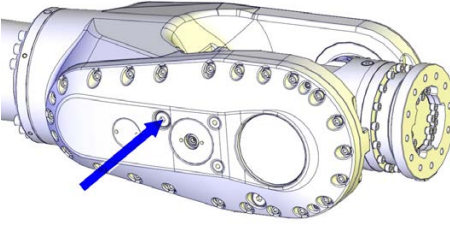



Continued

	Action	Note
2	<p> DANGER</p> <p>Turn off all:</p> <ul style="list-style-type: none"> • electric power supply • hydraulic pressure supply • air pressure supply <p>to the robot, before entering the safe-guarded space.</p>	
3	<p> WARNING</p> <p>Handling gearbox oil involves several safety risks, see Gearbox lubricants (oil or grease) on page 34.</p>	
4	<p> CAUTION</p> <p>The gearbox can contain an <i>excess pressure</i> that can be hazardous. Open the oil plug carefully in order to let the excess pressure out.</p>	
5	<p>Remove the oil plug from the drain hole and let the oil run into the vessel.</p>	 <p>xx1200000958</p>
6	<p>Place the oil collecting vessel underneath the oil drain plug.</p>	
7	<p>Remove the oil plug from the fill/level hole.</p> <p> Note</p> <p>The fill hole is opened to speed up the drainage.</p>	 <p>xx1200000959</p>
8	<p> WARNING</p> <p>Used oil is hazardous material and must be disposed of in a safe way. See section Decommissioning on page 799 for more information.</p>	
9	<p>Refill oil or refit the oil plug.</p>	<p>Tightening torque: 24 Nm.</p>

Continues on next page

Filling oil into the axis-5 gearbox

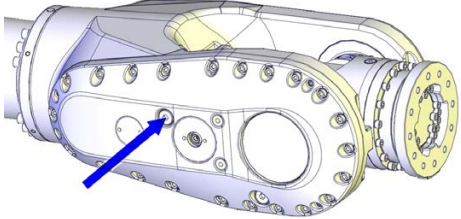
Use this procedure to refill the gearbox with oil.

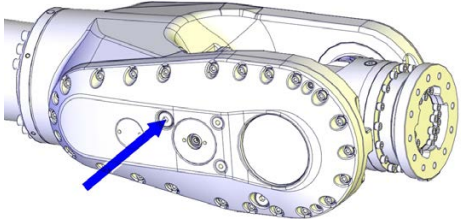
	Action	Note
1	Run the robot to calibration position.	
2	 DANGER Turn off all: <ul style="list-style-type: none"> • electric power supply • hydraulic pressure supply • air pressure supply to the robot, before entering the safe-guarded space.	
3	 WARNING Handling gearbox oil involves several safety risks, see Gearbox lubricants (oil or grease) on page 34 .	
4	Open the fill/level plug.	 <p>xx1200000959</p>
5	Refill the gearbox with oil.  Note The amount of oil to be filled depends on the amount previously being drained.	Type of oil and total amount is detailed in <i>Technical reference manual - Lubrication in gearboxes</i> .
6	Inspect the oil level at the oil fill/level hole (level plug).	 <p>xx1200000959</p> <p>Required oil level is: 0 - 10 mm below the oil plug hole. More information is found in Inspecting the oil level in axis-5 gearbox on page 122.</p>
7	Refit the oil plug.	Tightening torque: 24 Nm

Continues on next page

3 Maintenance

3.4.6 Changing oil, axis-5 gearbox

Continued

	Action	Note
8	 DANGER Make sure all safety requirements are met when performing the first test run.	

3.4.7 Changing oil, axis-6 gearbox

Location of oil plugs

The oil plugs of the gearbox are located as shown in the figure.

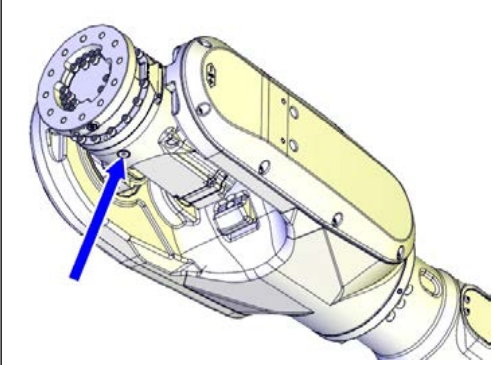
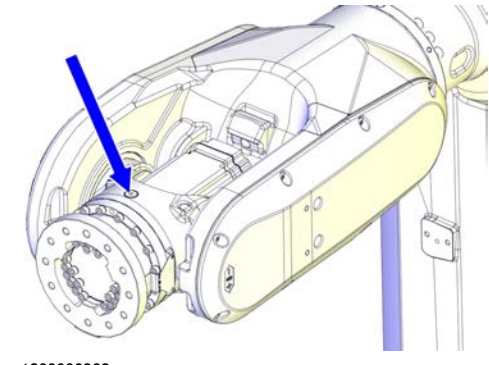
	
Oil drain plug	Oil fill plug
Tightening torque: 24 Nm.	Tightening torque: 24 Nm.

Required tools and equipment

Equipment, etc.	Article number	Note
Oil collecting vessel	-	The capacity of the vessel must be sufficient to take the complete amount of oil.
Oil dispenser	-	One example of oil dispenser can be found in section Type of lubrication in gearboxes on page 145 .
Standard toolkit	-	Content is defined in section Standard toolkit on page 814 .

Consumable

Material	Note
Lubricating oil	Information about the oil is found in <i>Technical reference manual - Lubrication in gearboxes</i> . See Type and amount of oil in gearboxes on page 145 .

Required documents

Document name	Document number	Note
<i>Technical reference manual - Lubrication in gearboxes</i>	3HAC042927-001	

Draining the axis-6 gearbox

Use this procedure to drain the gearbox.





	Action	Note
1	Jog the robot to calibration position.	

Continues on next page

3 Maintenance

3.4.7 Changing oil, axis-6 gearbox

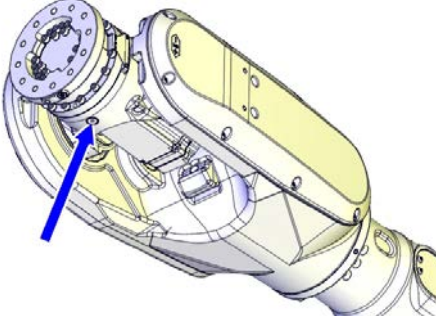
Continued

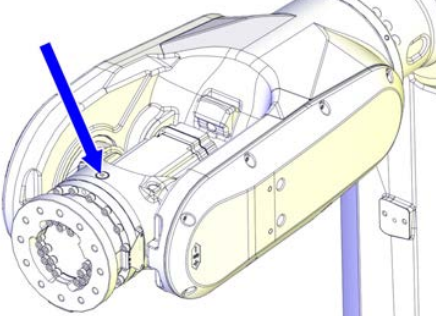



	Action	Note
2	<p> DANGER</p> <p>Turn off all:</p> <ul style="list-style-type: none"> • electric power supply • hydraulic pressure supply • air pressure supply <p>to the robot, before entering the safe-guarded space.</p>	
3	<p> WARNING</p> <p>Handling gearbox oil involves several safety risks, see Gearbox lubricants (oil or grease) on page 34.</p>	
4	<p> CAUTION</p> <p>The gearbox can contain an <i>excess pressure</i> that can be hazardous. Open the oil plug carefully in order to let the excess pressure out.</p>	
5	<p>Place the oil collecting vessel underneath the oil drain plug.</p>	
6	<p>Remove the oil plug from the drain hole and let the oil run into the vessel.</p>	 <p>xx120000962</p>
7	<p>Remove the oil plug from the fill hole.</p> <p> Note</p> <p>The fill hole is opened to speed up the drainage.</p>	 <p>xx120000963</p>

Continues on next page

	Action	Note
8	 WARNING Used oil is hazardous material and must be disposed of in a safe way. See section Decommissioning on page 799 for more information.	
9	Refill oil or refit the oil plugs.	Tightening torque: 24 Nm.

Filling oil into the axis-6 gearbox

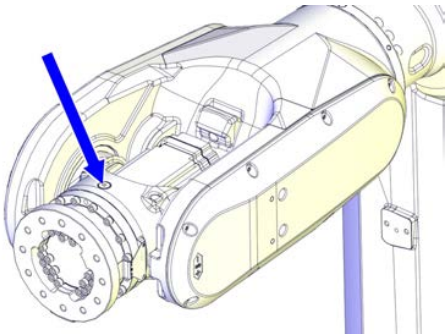
Use this procedure to refill the gearbox with oil.



	Action	Note
1	Jog axis 5 to horizontal position.	
2	 DANGER Turn off all: <ul style="list-style-type: none"> • electric power supply • hydraulic pressure supply • air pressure supply to the robot, before entering the safe-guarded space.	
3	 WARNING Handling gearbox oil involves several safety risks, see Gearbox lubricants (oil or grease) on page 34 .	
4	Open the fill plug.	 <p style="text-align: right; font-size: small;">xx1200000963</p>
5	Refill the gearbox with oil.  Note The amount of oil to be filled depends on the amount previously being drained.	Type of oil and total amount is detailed in <i>Technical reference manual - Lubrication in gearboxes</i> .

Continues on next page

3 Maintenance

3.4.7 Changing oil, axis-6 gearbox

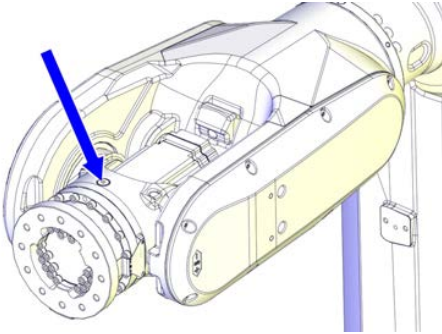
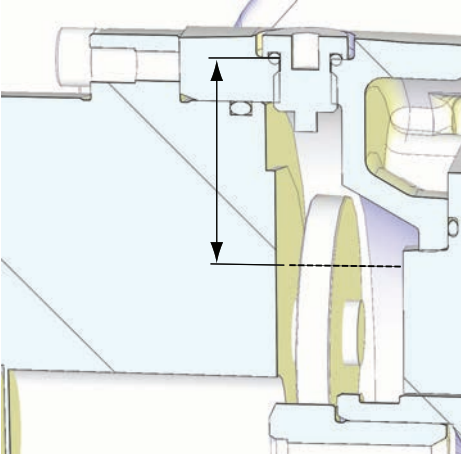
Continued

	Action	Note
6	<p>Check the oil level.</p> <p> Note</p> <p>The level is measured at the fill hole.</p>	<p>Method 1:</p>  <p>xx120000963</p> <ul style="list-style-type: none"> • IRB 6700 - 235/2.65, IRB 6700 - 205/2.80, IRB 6700 - 175/3.05, IRB 6700 - 150/3.20 50 mm ± 5 mm below the sealing surface of the oil plug. • IRB 6700 - 200/2.60, IRB 6700 - 155/2.85 50 mm ± 5 mm below the sealing surface of the oil plug. • IRB 6700 - 300/2.70, IRB 6700 - 245/3.00 45 mm ± 5 mm below the sealing surface of the oil plug.  <p>xx130000693</p> <p>More information is found in Inspecting the oil level in axis-6 gearbox on page 125.</p> <p>Method 2:</p> <p>Rotate axis 5 +77°.</p> <p>Required oil level is: 0 - 10 mm below the oil plug hole.</p>
7	<p>Refit the oil plug.</p>	<p>Tightening torque: 24 Nm</p>
8	<p> DANGER</p> <p>Make sure all safety requirements are met when performing the first test run.</p>	

3.4.8 Replacing the SMB battery

**Note**

The battery low alert (38213 Battery charge low) is displayed when the battery needs to be replaced. The recommendation to avoid an un-synchronized robot is to keep the power to the controller turned on until the battery is to be replaced.

**WARNING**

See [Hazards related to batteries on page 35](#).

Location of SMB battery

The SMB battery (SMB = serial measurement board) is located on the frame as shown in the figure below.

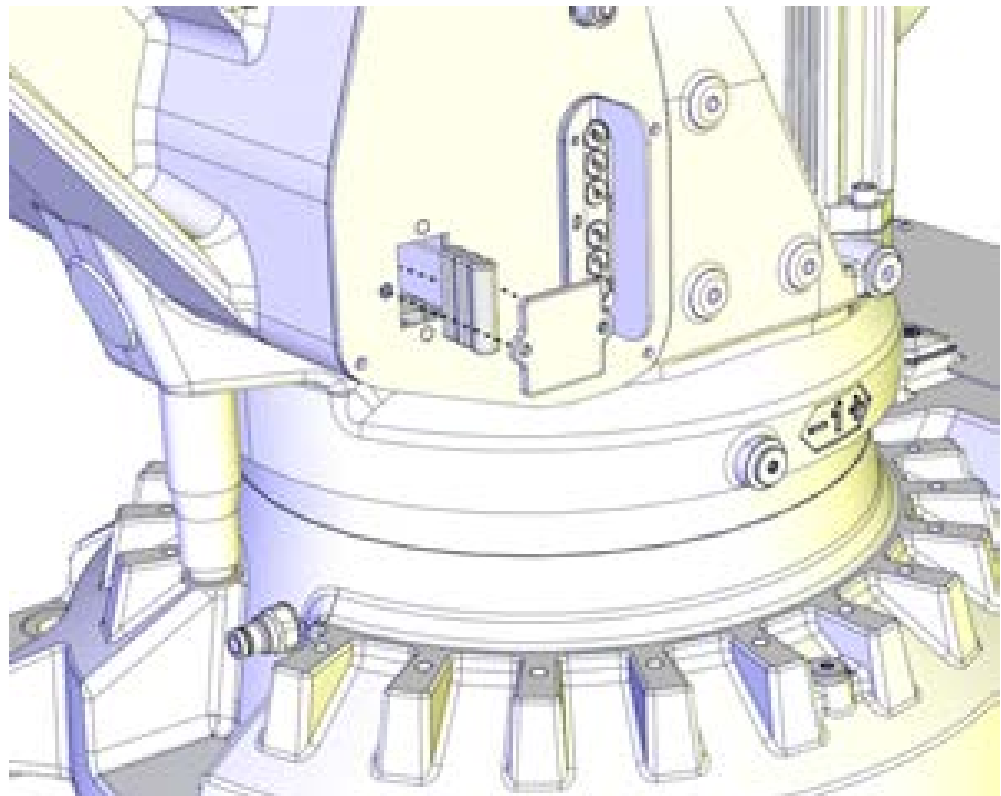

xx1200001069

Required tools

Equipment	Article number	Note
Standard toolkit	-	Content is defined in section Standard toolkit on page 814 .

Continues on next page

3 Maintenance

3.4.8 Replacing the SMB battery



Continued

Required spare parts

Spare part	Article number	Note
Battery unit	See <i>Product manual, spare parts - IRB 6700/IRB 6700Inv.</i> <i>Product manual, spare parts - IRB 6790</i>	Battery includes protection circuits. Only replace with the specified spare part or an ABB-approved equivalent.

Removing the battery



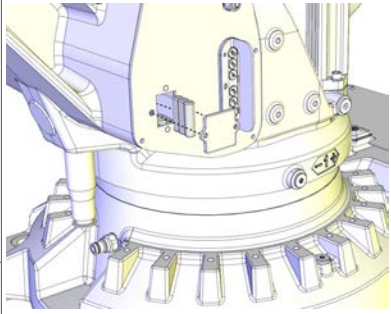

Use this procedure to remove the SMB battery.

Action	Note
1 Jog the robot to its calibration position.	This is done in order to facilitate updating of the revolution counter.
2  DANGER Turn off all: <ul style="list-style-type: none"> • electric power supply • hydraulic pressure supply • air pressure supply to the robot, before entering the safeguarded space.	
3  ELECTROSTATIC DISCHARGE (ESD) The unit is sensitive to ESD. Before handling the unit read the safety information in section The unit is sensitive to ESD on page 55 .	
4 Remove the SMB battery cover by unscrewing the attachment screws.  CAUTION Clean cover from metal residues before opening. Metal residues can cause shortage on the boards which can result in hazardous failures.	 xx1200001069
5 Pull out the battery and disconnect the battery cable.	
6 Remove the SMB battery. Battery includes protection circuits. Only replace with a specified spare part or with an ABB-approved equivalent.	

Continues on next page

Refitting the battery

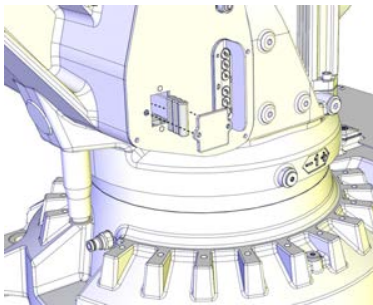
Use this procedure to refit the SMB battery.

	Action	Note
1	 DANGER Turn off all: <ul style="list-style-type: none"> • electric power supply • hydraulic pressure supply • air pressure supply to the robot, before entering the safeguarded space.	
2	 ELECTROSTATIC DISCHARGE (ESD) The unit is sensitive to ESD. Before handling the unit read the safety information in section <i>The unit is sensitive to ESD on page 55</i> .	
3	Connect the battery cable and install the battery pack into the SMB/battery recess.	 xx1200001069
4	Secure the SMB battery cover with its attachment screws.	
5	Update the revolution counters.	See <i>Updating revolution counters on IRC5 robots on page 775</i> .
6	 DANGER Make sure all safety requirements are met when performing the first test run.	

3 Maintenance

3.5.1 Lubricating the spherical roller bearing, balancing device

3.5 Lubrication activities

3.5.1 Lubricating the spherical roller bearing, balancing device

Location of spherical roller bearing

The spherical roller bearing is located in the link ear of the balancing device.

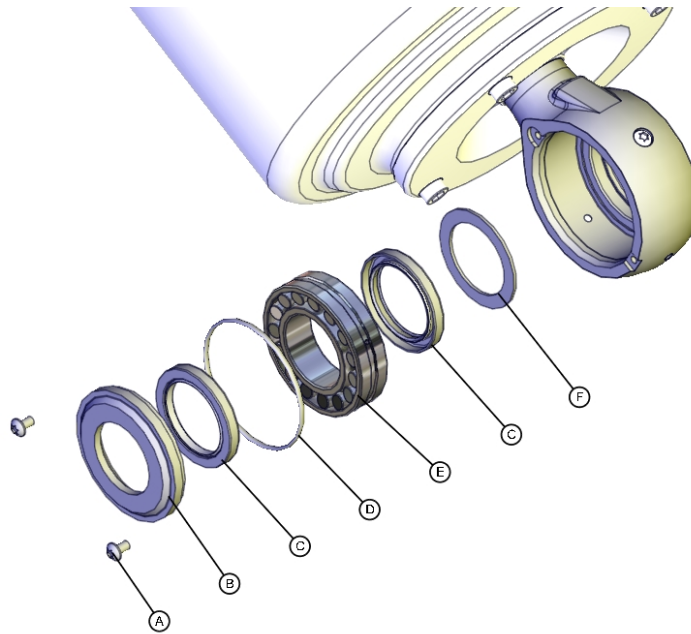

xx1300000773

A	Attachment screws M6x10 quality 8.8-A2F (2 pcs)
B	End cover
C	Radial sealing with dust lip, 50x68x8 (2 pcs)
D	O-ring 85x3
E	Spherical roller bearing
F	Washer



Consumables

Equipment, etc.	Article number	Note
Grease	3HAA1001-294	Tribol GR 100-0 PD, 50 ml Used for lubrication of the spherical roller bearing.

Continues on next page

Lubricating the spherical roller bearing

Use this procedure to lubricate the spherical roller bearing.

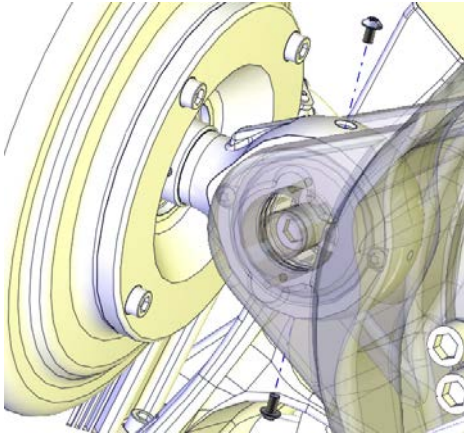
	Action	Note
1	<p> DANGER</p> <p>Turn off all:</p> <ul style="list-style-type: none"> • electric power supply • hydraulic pressure supply • air pressure supply <p>to the robot, before entering the safe-guarded space.</p>	
2	<p> CAUTION</p> <p>Always cut the paint with a knife and grind the paint edge when disassembling parts. See Cut the paint or surface on the robot before replacing parts on page 192.</p>	
3	<p>Unscrew both screws in link ear and fill the bearing with grease from the upper hole until the grease appears in the lower hole.</p>	<p>Grease: 3HAA1001-294</p>  <p>xx1300000783</p>
4	<p>Refit the two screws and wipe clean from residual grease.</p>	

3 Maintenance

3.6.1 Cleaning the IRB 6700

3.6 Cleaning activities

3.6.1 Cleaning the IRB 6700



DANGER

Turn off all:

- electric power supply
- hydraulic pressure supply
- air pressure supply

to the robot, before entering the safeguarded space.

General

To secure high uptime it is important that the IRB 6700 is cleaned regularly. The frequency of cleaning depends on the environment in which the product works. Different cleaning methods are allowed depending on the type of protection of the IRB 6700.



Note

Always verify the protection type of the robot before cleaning.

Oil spills

Oil spills from gearboxes

Use the following procedure if any oil spills are detected that can be suspected to originate from a gearbox.

- 1 Inspect that the oil level in the suspected gearbox is according to the recommendations, see [Inspection activities on page 108](#).
- 2 Write down the oil level.
- 3 Inspect the oil level again after, for example, 6 months.
- 4 If the oil level is decreased then replace the gearbox.

Special cleaning considerations

This section specifies some special considerations when cleaning the robot.

- Always use cleaning equipment as specified. Any other cleaning equipment may shorten the life of the robot.
- Always check that all protective covers are fitted to the robot before cleaning.
- Never point the water jet at connectors, joints, sealings, or gaskets.
- Do not use compressed air to clean the robot.
- Never use solvents that are not approved by ABB to clean the robot.
- Do not spray from a distance closer than 0.4 m.
- Do not remove any covers or other protective devices before cleaning the robot.

Continues on next page

Cleaning methods

The following table defines what cleaning methods are allowed depending on the protection type.

Protection type	Cleaning method			
	Vacuum cleaner	Wipe with cloth	Rinse with water	High pressure water or steam
Standard	Yes	Yes. With light cleaning detergent.	Yes. It is highly recommended that the water contains a rust-prevention solution and that the manipulator is dried afterwards.	No
Foundry Plus	Yes	Yes. With light cleaning detergent or spirit.	Yes. It is highly recommended that the water contains a rust-prevention solution.	Yes ⁱ . It is highly recommended that the water and steam contains rust preventive, without cleaning detergents.

ⁱ Perform according to section [Cleaning with water and steam on page 183](#).

Cleaning with water and steam

Instructions for rinsing with water

ABB robots with protection types *Standard*, *Foundry Plus*, *Wash*, or *Foundry Prime* can be cleaned by rinsing with water (water cleaner).¹

The following list defines the prerequisites:

- Maximum water pressure at the nozzle: 700 kN/m² (7 bar)¹
- Fan jet nozzle should be used, min. 45° spread
- Minimum distance from nozzle to encapsulation: 0.4 meters
- Maximum flow: 20 liters/min¹

¹ Typical tap water pressure and flow

Instructions for steam or high pressure water cleaning

ABB robots with protection types *Foundry Plus*, *Wash*, or *Foundry Prime* can be cleaned using a steam cleaner or high pressure water cleaner.²

The following list defines the prerequisites:

- Maximum water pressure at the nozzle: 2500 kN/m² (25 bar)
- Fan jet nozzle should be used, min. 45° spread
- Minimum distance from nozzle to encapsulation: 0.4 meters
- Maximum water temperature: 80° C

Cables

Movable cables need to be able to move freely:

- Remove waste material, such as sand, dust and chips, if it prevents cable movement.

¹ See [Cleaning methods on page 183](#) for exceptions.

² See [Cleaning methods on page 183](#) for exceptions.

Continues on next page

3 Maintenance

3.6.1 Cleaning the IRB 6700

Continued

- Clean the cables if they have a crusty surface, for example from dry release agents.

Cooling fans

Inspect the air supply inlet of the the motor cooling fans. Clean to remove any contamination that could hinder the air supply.

4 Repair

4.1 Introduction

Structure of this chapter

This chapter describes repair activities for the IRB 6700. Each procedure contains the information required to perform the activity, for example spare parts numbers, required special tools, and materials.



WARNING

Repair activities not described in this chapter must only be carried out by ABB.

Report replaced units



Note

When replacing a part on the IRB 6700, report to your local ABB the serial number, the article number, and the revision of both the replaced unit and the replacement unit.

This is particularly important for safety equipment to maintain the safety integrity of the installation.

Safety information

Make sure to read through the chapter [Safety on page 19](#) before commencing any service work.



Note

If the IRB 6700 is connected to power, always make sure that the IRB 6700 is connected to protective earth and a residual current device (RCD) before starting any repair work.

For more information see:

- *Product manual - OmniCore V250XT*
- *Product manual - IRC5*
- *Product manual - IRC5 Panel Mounted Controller*

4 Repair

4.2.1 Performing a leak-down test

4.2 General procedures

4.2.1 Performing a leak-down test

When to perform a leak-down test

After refitting any motor and gearbox, the integrity of all seals enclosing the gearbox oil must be tested. This is done in a leak-down test.

Required equipment

Equipment, etc.	Article number	Note
Leak-down tester	-	
Leak detection spray	-	

Performing a leak-down test

	Action	Note
1	Finish the refitting procedure of the motor or gear in question.	
2	Remove the upper oil plug on the gear and replace it with the leak-down tester. Regulators, which are included in the leak-down test, may be required.	
3	Use caution, apply compressed air and raise the pressure with the knob until the correct value is shown on the manometer.  CAUTION The pressure must under no circumstance be higher than 0.25 bar (20-25 kPa). Also during the time when the pressure is raised.	Correct value: 0.2-0.25 bar (20-25 kPa)
4	Disconnect the compressed air supply.	
5	Wait for approximately 8-10 minutes and make sure that no pressure loss occurs.	If the compressed air is significantly colder or warmer than the gearbox to be tested, a slight pressure increase or decrease may occur. This is quite normal.
6	If any pressure drop occurred, then localize the leak as described in step 7. If no pressure drop occurred, then remove the leak-down tester and refit the oil plug. The test is complete.	
7	Spray any suspected leak areas with the leak detection spray. Bubbles indicate a leak.	
8	When the leak has been localized, take the necessary measures to correct the leak.	

4.2.2 Mounting instructions for bearings

General

This section describes how to mount and grease different types of bearings on the robot.

Equipment

Equipment, etc.	Article number	Note
Grease	3HAC042536-001	Shell Gadus S2 Used to grease the bearings, if not specified otherwise.

Assembly of all bearings

Attend to the following instructions while mounting a bearing on the robot.

	Action	Note
1	To avoid contamination, let a new bearing remain in its wrapping until it is time for fitting.	
2	Ensure that the parts included in the bearing fitting are free from burrs, grinding waste, and other contamination. Cast components must be free of foundry sand.	
3	Bearing rings, inner rings, and roller elements must not be subjected to direct impact. The roller elements must not be exposed to any stresses during the assembly work.	

Assembly of tapered bearings

Follow the preceding instructions for the assembly of the bearings when mounting a tapered bearing on the robot.

In addition to those instructions, the following procedure must be carried out to enable the roller elements to adjust to the correct position against the race flange.

	Action	Note
1	Tension the bearing gradually until the recommended pre-tension is achieved.  Note The roller elements must be rotated a specified number of turns before pre-tensioning is carried out and also rotated during the pre-tensioning sequence.	
2	Make sure the bearing is properly aligned as this will directly affect the durability of the bearing.	

Greasing of bearings



Note

This instruction is not valid for solid oil bearings.

Continues on next page

4 Repair

4.2.2 Mounting instructions for bearings

Continued

The bearings must be greased after assembly according to the following instructions:

- The bearings must not be completely filled with grease. However, if space is available beside the bearing fitting, the bearing may be totally filled with grease when mounted, as excessive grease will be pressed out from the bearing when the robot is started.
- During operation, the bearing should be filled to 70-80% of the available volume.
- Ensure that grease is handled and stored properly to avoid contamination.

Grease the different types of bearings as following description:

- *Grooved ball bearings* must be filled with grease from both sides.
- *Tapered roller bearings* and axial needle bearings must be greased in the split condition.

4.2.3 Mounting instructions for sealings

General

This section describes how to mount different types of sealings.

Equipment

Consumable	Article number	Note
Grease	3HAC042536-001	Shell Gadus S2

Rotating sealings

The procedure below describes how to fit rotating sealings.



CAUTION

Please observe the following before commencing any assembly of sealings:

- Protect the sealing during transport and mounting, especially the main lip.
- Keep the sealing in its original wrappings or protect it well before actual mounting.
- The fitting of sealings and gears must be carried out on clean workbenches.
- Use a protective sleeve for the main lip during mounting, when sliding over threads, keyways or other sharp edges.

Action	Note
1 Check the sealing to ensure that: <ul style="list-style-type: none"> • The sealing is of the correct type. • There is no damage on the main lip. 	
2 Inspect the shaft surface before mounting. If scratches or damage are found, the shaft must be replaced since it may result in future leakage. Do not try to grind or polish the shaft surface to get rid of the defect.	
3 Lubricate the sealing with grease just before fitting. (Not too early - there is a risk of dirt and foreign particles adhering to the sealing.) Fill 2/3 of the space between the dust lip and the main lip with grease. If the sealing is without dust lip, just lubricate the main lip with a thin layer of grease.	<p>Article number is specified in Equipment on page 189.</p> <p>xx2000000071</p> <p>A Main lip B Grease C Dust lip</p>

Continues on next page

4 Repair

4.2.3 Mounting instructions for sealings

Continued

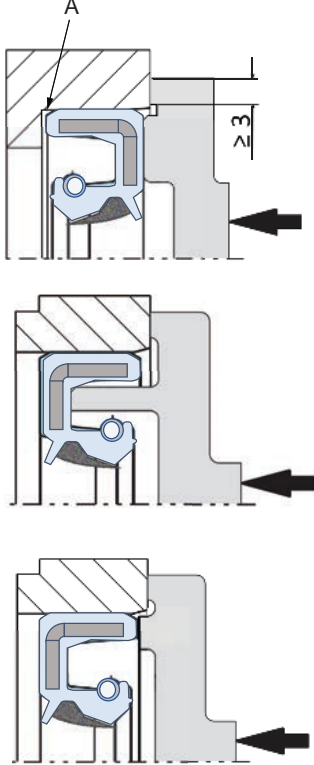
	Action	Note
4	<p>Mount the sealing correctly with a mounting tool. Never hammer directly on the sealing as this may result in leakage.</p>	 <p>xx2000000072</p> <p>A Gap</p>

Flange sealings and static sealings

The following procedure describes how to fit flange sealings and static sealings.

	Action
1	<p>Check the flange surfaces. They must be even and free from pores. It is easy to check flatness using a gauge on the fastened joint (without sealing compound). If the flange surfaces are defective, the parts may not be used because leakage could occur.</p>
2	<p>Clean the surfaces properly in accordance with the recommendations of ABB.</p>
3	<p>Distribute the sealing compound evenly over the surface, preferably with a brush.</p>
4	<p>Tighten the screws evenly when fastening the flange joint.</p>

O-rings

The following procedure describes how to fit o-rings.

	Action	Note
1	<p>Ensure that the correct o-ring size is used.</p>	
2	<p>Check the o-ring for surface defects, burrs, shape accuracy, or deformation.</p>	<p>Defective o-rings, including damaged or deformed o-rings, may not be used.</p>

Continues on next page

	Action	Note
3	Check the o-ring grooves. The grooves must be geometrically correct and should be free of pores and contamination.	
4	Lubricate the o-ring with grease.	
5	Tighten the screws evenly while assembling.	
6	Check that the o-ring is not squashed outside the o-ring groove.	

4 Repair

4.2.4 Cut the paint or surface on the robot before replacing parts

4.2.4 Cut the paint or surface on the robot before replacing parts

General

Follow the procedures in this section whenever breaking the paint of the robot during replacement of parts.

Required equipment

Equipment	Spare parts	Note
Cleaning agent		Ethanol
Knife		
Lint free cloth		
Touch up paint Standard/Foundry Plus	3HAC067974-001	Graphite White
Touch up paint Standard/Foundry Plus	3HAC037052-001	ABB Orange

Removing

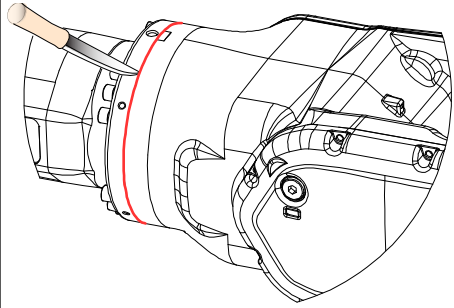
Action	Description
1 Cut the paint with a knife in the joint between the part that will be removed and the structure, to avoid that the paint cracks.	 xx0900000121
2 Carefully grind the paint edge that is left on the structure to a smooth surface.	

4.2.5 The brake release buttons may be jammed after service work

4.2.5 The brake release buttons may be jammed after service work

Description

The brake release unit has push-buttons for the brake release of each axis motor. When service work is performed inside the SMB recess that includes removal and refitting of the brake release unit, the brake release buttons may be jammed after refitting.

**DANGER**

If the power is turned on while a brake release button is jammed in depressed position, the affected motor brake is released. This may cause serious personal injuries and damage to the robot.

Elimination

To eliminate the danger after service work has been performed inside the SMB recess, follow the procedure below.

	Action
1	Make sure the power is turned off.
2	Remove the push-button guard, if necessary.
3	Verify that the push-buttons of the brake release unit are working by pressing them down, one by one. Make sure none of the buttons are jammed in the tube.
4	If a button gets jammed in the depressed position, the alignment of the brake release unit must be adjusted so that the buttons can move freely in their tubes.

4 Repair

4.3.1 Attaching lifting accessories to complete arm system (IRB 6700-235/2.65, -205/2.80, -175/3.05, -150/3.20, -200/2.60, -155/2.85)

4.3 Lifting associated procedures

4.3.1 Attaching lifting accessories to complete arm system (IRB 6700-235/2.65, -205/2.80, -175/3.05, -150/3.20, -200/2.60, -155/2.85)

Validity of this section - IRB 6700 -235/2.65, -205/2.80, -175/3.05, -150/3.20, -200/2.60, -155/2.85



Note

Some sections have similar titles. Make sure to use the correct section, to find information about a certain IRB 6700 variant.

This section describes how to attach lifting accessories to variants IRB 6700 -235/2.65, -205/2.80, -175/3.05, -150/3.20, -200/2.60, -155/2.85

How to attach lifting accessories to variants IRB 6700 -300/2.70, -245/3.00 see section 4.3.2 *Attaching lifting accessories to complete arm system*.

Definition of the complete arm system

The complete arm system consists of the following parts of the robot:

- upper arm
- wrist
- lower arm
- frame

Continues on next page

4.3.1 Attaching lifting accessories to complete arm system (IRB 6700-235/2.65, -205/2.80, -175/3.05, -150/3.20, -200/2.60, -155/2.85)

Continued

Attachment points of lifting accessory

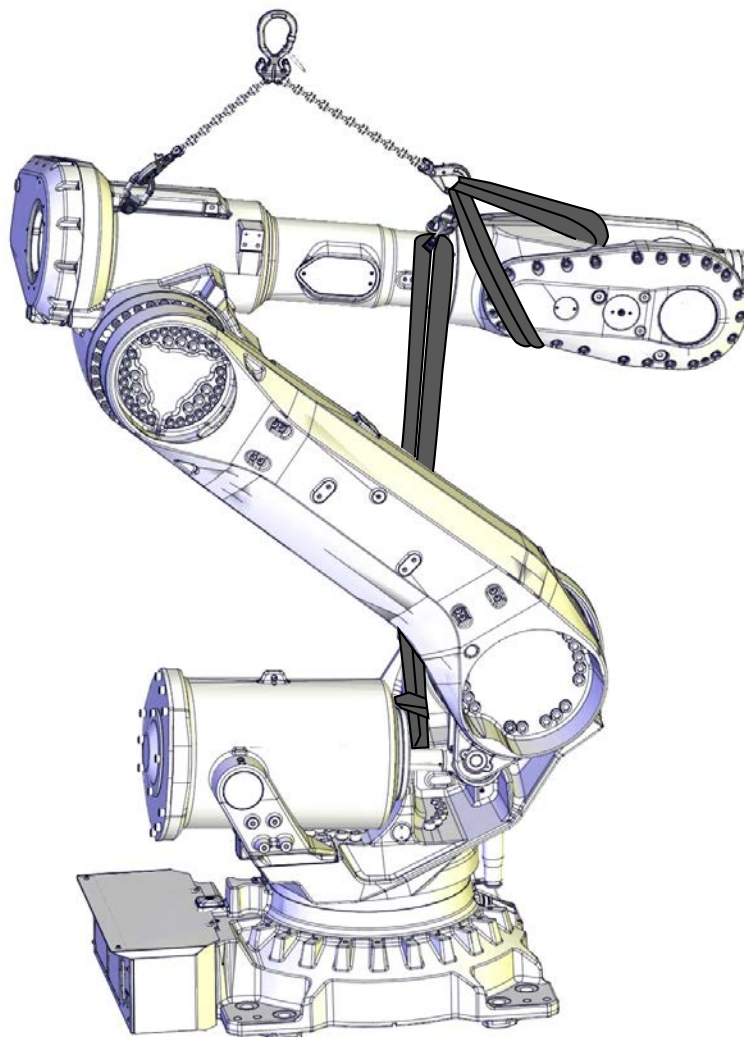

Required tools

Equipment, etc.	Article number	Note
Lifting eye	3HAC16131-1	M12
Lifting eye	3HAC16131-1	M12
Fender washer	-	Outer diameter: minimum 26 mm, maximum 30 mm, hole diameter: 13 mm, thickness: 3 mm.
Lifting shackle	-	SA-10-8-NA1
Roundsling, 1.5 m	-	Length: 1.5 m. Lifting capacity: 2,000 kg.
Roundsling, 1 m	-	Length: 1 m, lifting capacity: 1,000 kg.
Lifting accessory (chain)	3HAC15556-1	Lifting instruction 3HAC15880-2 enclosed.
Standard toolkit	-	Content is defined in section Standard toolkit on page 814 .

Continues on next page

4 Repair

4.3.1 Attaching lifting accessories to complete arm system (IRB 6700-235/2.65, -205/2.80, -175/3.05, -150/3.20, -200/2.60, -155/2.85)



Continued

Attaching the lifting accessories

Robot position

Use this procedure to jog the robot into position.

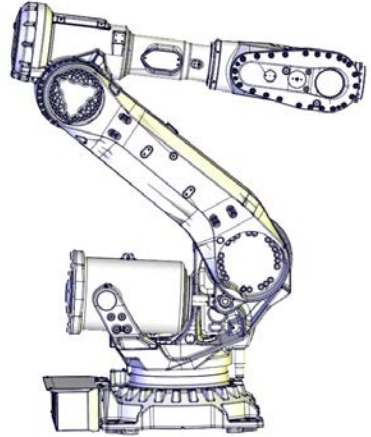

Valid for variants IRB 6700 - 235/2.65, IRB 6700 - 205/2.80, IRB 6700 - 175/3.05, IRB 6700 - 150/3.20, IRB 6700 - 200/2.60, IRB 6700 - 155/2.85.

	Action	Note
1	<p>Jog the robot into position:</p> <ul style="list-style-type: none"> • Axis 1: no significance as long as the robot is secured to the foundation. • Axis 2: -40° • Axis 3: +65° (approximately) • Axis 4: calibration position (0°) • Axis 5: +90° • Axis 6: calibration position (0°) 	 <p>xx1200001132</p>
2	<p> DANGER</p> <p>Turn off all:</p> <ul style="list-style-type: none"> • electric power supply • hydraulic pressure supply • air pressure supply <p>to the robot, before entering the robot working area.</p>	

Attaching lifting accessories to the arm system

Use this procedure to attach the lifting accessories.



Valid for variants IRB 6700 - 235/2.65, IRB 6700 - 205/2.80, IRB 6700 - 175/3.05, IRB 6700 - 150/3.20, IRB 6700 - 200/2.60, IRB 6700 - 155/2.85.

	Action	Note
1	<p> DANGER</p> <p>Make sure that all supplies for electrical power, hydraulic pressure, and air pressure are turned off.</p>	
2	<p> CAUTION</p> <p>The complete arm system weigh (according to variants) 1100 kg.</p> <p>All lifting accessories used must be sized accordingly.</p>	

Continues on next page

4.3.1 Attaching lifting accessories to complete arm system (IRB 6700-235/2.65, -205/2.80, -175/3.05, -150/3.20, -200/2.60, -155/2.85)

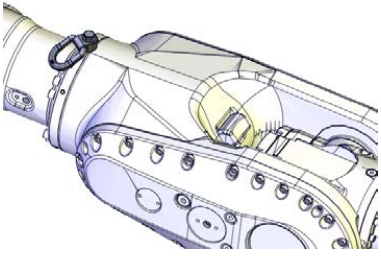
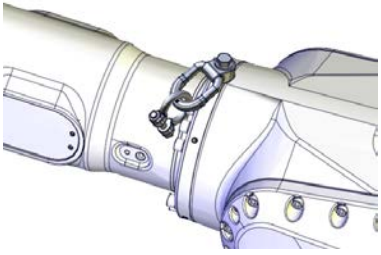
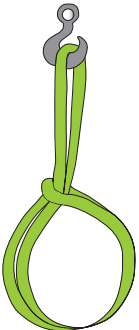
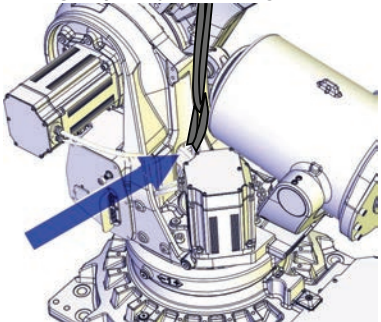
Continued

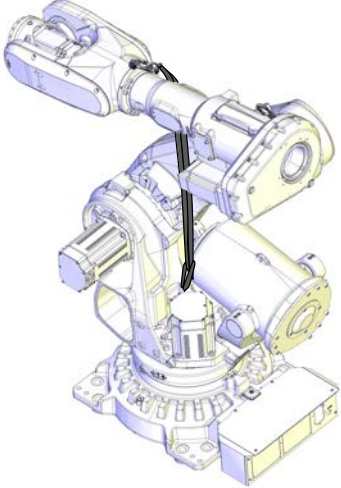

	Action	Note
3	Fit a lifting eye to the wrist.	Lifting eye: 3HAC16131-1  xx1200001133
4	Fit a lifting shackle in the wrist lifting eye.	Lifting shackle: SA-10-8-NA1  xx1200001234
5	Run a roundsling through the hole in the frame. Attach the roundsling choked. See figure!  xx1400000730	Roundsling, 1.5 m: Length: 1.5 m. Lifting capacity: 2,000 kg.  xx1200001209
6	Attach the roundsling to the shackle on the wrist. 7 Jog axis-3 slowly until the roundsling is stretched (approximately +58°), to carry the weight of the lower arm and frame.  WARNING Without the roundsling the weight of the lower arm and frame is applied to the axis-3 gear during lifting, which risks to damage the gear.	 xx1200001235

Continues on next page

4 Repair

4.3.1 Attaching lifting accessories to complete arm system (IRB 6700-235/2.65, -205/2.80, -175/3.05, -150/3.20, -200/2.60, -155/2.85)

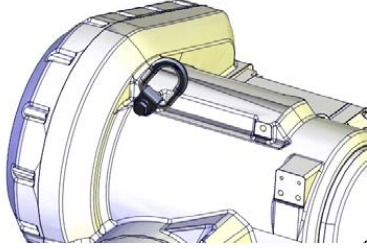
Continued

	Action	Note
8	<p>Fit a lifting eye in the arm house, with a fender washer underneath.</p>  <p>xx1400002196</p> <p>Fender washer</p>	<p>Lifting eye: 3HAC16131-1 Fender washer. Outer diameter: minimum 26 mm, maximum 30 mm, hole diameter: 13 mm, thickness: 3 mm.</p>  <p>xx1200001134</p>
9	<p>Attach the Lifting accessory (chain) to an overhead crane (or similar) and then to the lifting eye in the arm house and to a roundsling run through the wrist.</p>	<p>Lifting accessory (chain): 3HAC15556-1 Roundsling, 1 m: Length: 1 m, lifting capacity: 1,000 kg.</p>  <p>xx1200001236</p>

4.3.2 Attaching lifting accessories to complete arm system (IRB 6700 -300/2.70, -245/3.00)

4.3.2 Attaching lifting accessories to complete arm system (IRB 6700 -300/2.70, -245/3.00)

Validity of this section - IRB 6700 -300/2.70, -245/3.00



Note

Some sections have similar titles. Make sure to use the correct section, to find information about a certain IRB 6700 variant.

This section describes how to attach lifting accessories to variants IRB 6700 -300/2.70, -245/3.00

How to attach lifting accessories to variants IRB 6700 -235/2.65, -205/2.80, -175/3.05, -150/3.20, -200/2.60, -155/2.85 see section 4.3.1 *Attaching lifting accessories to complete arm system*.

Definition of the complete arm system

The complete arm system consists of the following parts of the robot:

- upper arm
- wrist
- lower arm
- frame, including the balancing device.

Continues on next page

4 Repair

4.3.2 Attaching lifting accessories to complete arm system (IRB 6700 -300/2.70, -245/3.00)

Continued

Attachment points of lifting accessory

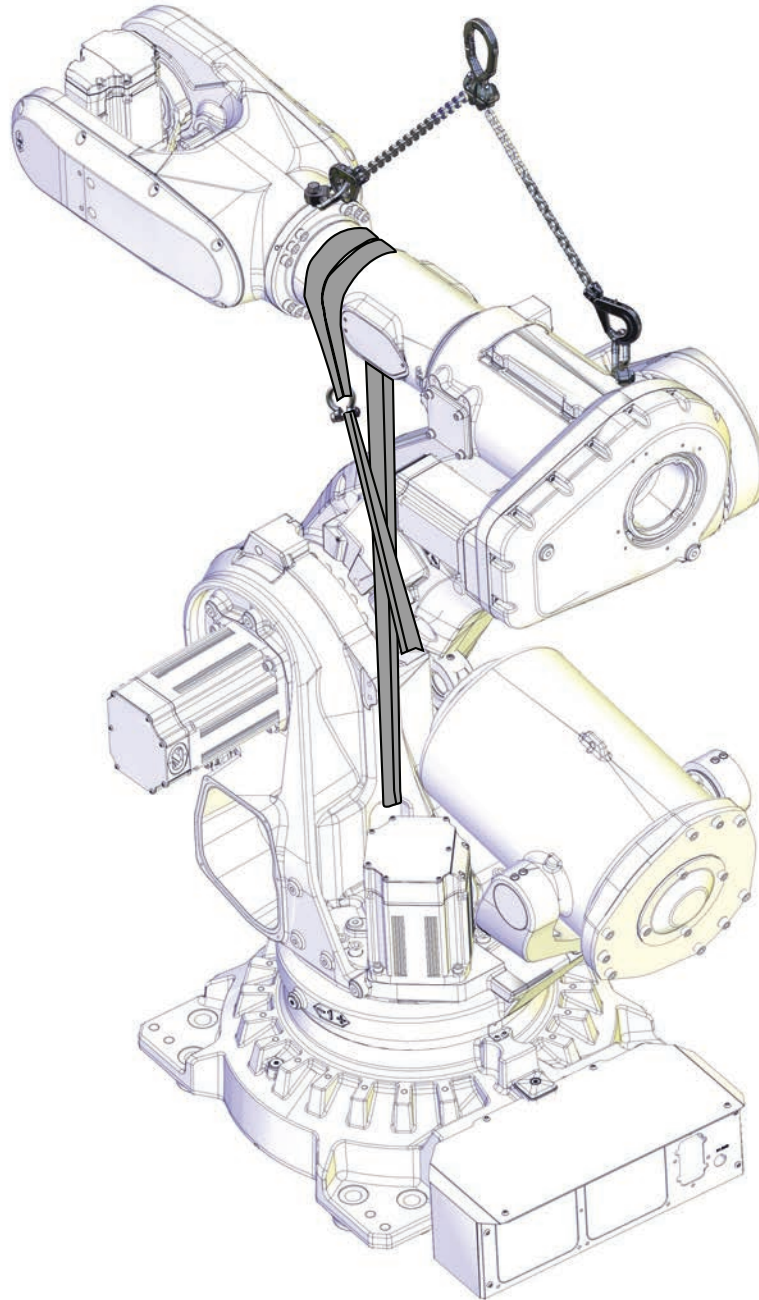

Required tools

Equipment, etc.	Article number	Note
Lifting eye	3HAC16131-1	M12
Lifting eye	3HAC16131-1	M12
Fender washer	-	Outer diameter: minimum 26 mm, maximum 30 mm, hole diameter: 13 mm, thickness: 3 mm.
Lifting shackle	-	SA-10-8-NA1

Continues on next page

4.3.2 Attaching lifting accessories to complete arm system (IRB 6700 -300/2.70, -245/3.00)

Continued



Equipment, etc.	Article number	Note
Roundsling, 1.5 m	-	Length: 1.5 m. Lifting capacity: 2,000 kg.
Roundsling, 1 m	-	Length: 1 m, lifting capacity: 1,000 kg.
Lifting accessory (chain)	3HAC15556-1	Lifting instruction 3HAC15880-2 enclosed.
Standard toolkit	-	Content is defined in section Standard toolkit on page 814 .

Attaching the lifting accessories

Robot position

	Action	Note
1	Jog the robot into position: <ul style="list-style-type: none"> • Axis 1: no significance (as long as the robot is secured to the foundation) • Axis 2: -45° • Axis 3: +65° • Axis 4: 0° • Axis 5: +90° • Axis 6: calibration position (0°) 	
2	 DANGER Turn off all: <ul style="list-style-type: none"> • electric power supply • hydraulic pressure supply • air pressure supply to the robot, before entering the robot working area.	

Attaching the lifting accessories to the arm system



	Action	Note
1	 DANGER Make sure that all supplies for electrical power, hydraulic pressure, and air pressure are turned off.	
2	 CAUTION The complete arm system weighs 1300 Kg. All lifting accessories used must be sized accordingly!	

Continues on next page

4 Repair

4.3.2 Attaching lifting accessories to complete arm system (IRB 6700 -300/2.70, -245/3.00)

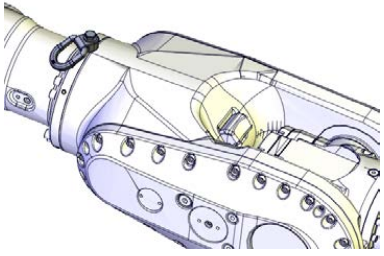
Continued

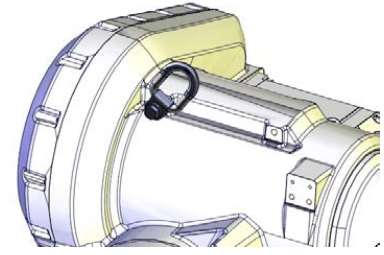
	Action	Note
3	Fit a lifting eye to the wrist.	Lifting eye: 3HAC16131-1 
4	Fit a lifting eye to the arm house, with a fender washer underneath. 	Lifting eye: 3HAC16131-1 Fender washer. Outer diameter: minimum 26 mm, maximum 30 mm, hole diameter: 13 mm, thickness: 3 mm. 

Continues on next page

Attach the lifting chains

Use this procedure to attach the Lifting accessory (chain).

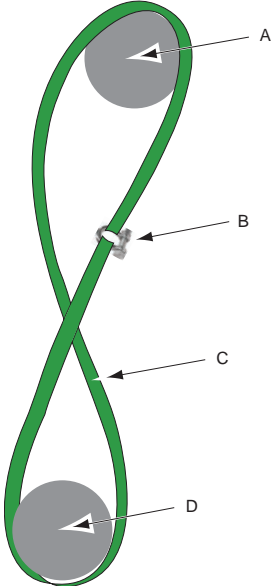
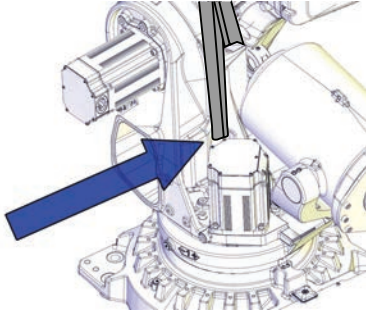

	Action	Note
1	<p>Run a roundsling through the hole in the frame, continue up and over the upper arm.</p> <p> Tip</p> <p>When attaching the roundsling, make sure to cross it over, creating a figure 8 of the roundsling. This will prevent the roundsling from gliding.</p>  <p>A Upper arm B Shackle C Roundsling D Hole in frame</p>	<p>Roundsling, 2.5 m: Length: 2.5 m. Lifting capacity: 2,000 kg.</p> 

Continues on next page

4 Repair

4.3.2 Attaching lifting accessories to complete arm system (IRB 6700 -300/2.70, -245/3.00)

Continued

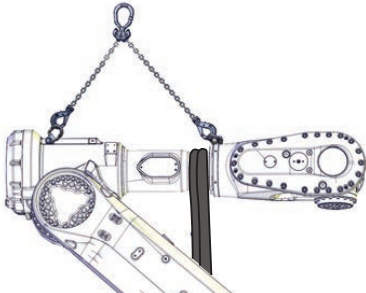
	Action	Note
2	Connect the roundsling with a shackle.	Lifting shackle SA-10-8-NA1  xx1400000729
3	Use caution and jog axis-3 slowly to stretch the roundsling.  Note Make sure the roundsling is stretched, so it can carry the weight of the frame.	
4	Attach the Lifting accessory (chain) to an overhead crane (or similar) and then to the lifting eye in the arm house and to the lifting eye in the wrist.	Lifting accessory (chain): 3HAC15556-1 

4.3.3 Attaching lifting accessories to an un-separated lower and upper arm (IRB 6700-235/2.65, -205/2.80, -175/3.05, -150/3.20, -200/2.60, -155/2.85)

4.3.3 Attaching lifting accessories to an un-separated lower and upper arm (IRB 6700-235/2.65, -205/2.80, -175/3.05, -150/3.20, -200/2.60, -155/2.85)

Validity of this section - IRB 6700 -235/2.65, -205/2.80, -175/3.05, -150/3.20, -200/2.60, -155/2.85



Note

Some sections have similar titles. Make sure to use the correct section, to find information about a certain IRB 6700 variant.

This section describes how to attach lifting accessories to variants IRB 6700 -235/2.65, -205/2.80, -175/3.05, -150/3.20, -200/2.60, -155/2.85

How to attach lifting accessories to variants IRB 6700 -300/2.70, -245/3.00 see section 4.3.4 *Attaching lifting accessories to an unseparated lower and upper arm.*

Attachment points of lifting accessory

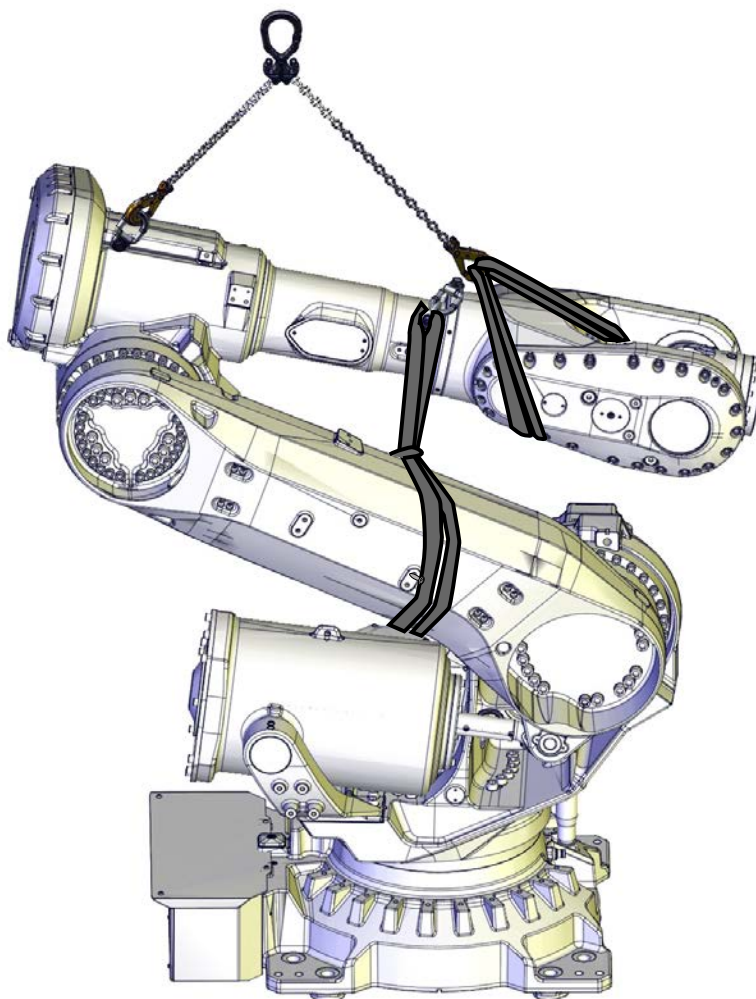

xx1200001254

Continues on next page

4 Repair

4.3.3 Attaching lifting accessories to an un-separated lower and upper arm (IRB 6700-235/2.65, -205/2.80, -175/3.05, -150/3.20, -200/2.60, -155/2.85)

Continued

Required tools

Equipment, etc.	Article number	Note
Lifting eye	3HAC16131-1	M12
Lifting eye	3HAC16131-1	M12
Fender washer	-	Outer diameter: minimum 26 mm, maximum 30 mm, hole diameter: 13 mm, thickness: 3 mm.
Lifting shackle	-	SA-10-8-NA1
Roundsling, 1.5 m	-	Length: 1.5 m. Lifting capacity: 2,000 kg.
Roundsling, 1 m	-	Length: 1 m, lifting capacity: 1,000 kg.
Lifting accessory (chain)	3HAC15556-1	Lifting instruction 3HAC15880-2 enclosed.
Standard toolkit	-	Content is defined in section Standard toolkit on page 814 .

Attaching lifting accessories to the lower and upper arm

Robot position

Use this procedure to jog the robot into position.

Valid for variants IRB 6700 - 235/2.65, IRB 6700 - 205/2.80, IRB 6700 - 175/3.05, IRB 6700 - 150/3.20, IRB 6700 - 200/2.60, IRB 6700 - 155/2.85.

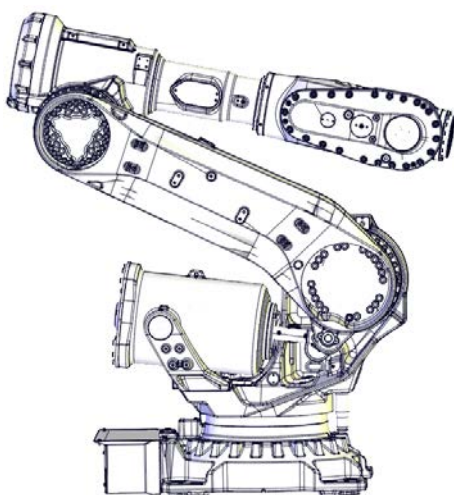
	Action	Note
1	 Note When jogging the axis-2 into position check that the balancing device ear and the ear on the lower arm is not colliding!	
2	Jog the robot into position: <ul style="list-style-type: none"> • Axis-1: no significance as long as the robot is secured to the foundation • Axis-2: -45° • Axis-3: +65° (approximately) • Axis-4: 0° • Axis-5: 0° • Axis-6: 0°. 	 <p>xx1200001250</p>

Continues on next page

4.3.3 Attaching lifting accessories to an un-separated lower and upper arm (IRB 6700-235/2.65, -205/2.80, -175/3.05, -150/3.20, -200/2.60, -155/2.85)

Continued

	Action	Note
3	 <p>DANGER</p> <p>Turn off all:</p> <ul style="list-style-type: none"> • electric power supply • hydraulic pressure supply • air pressure supply <p>to the robot, before entering the robot working area.</p>	

Attaching lifting accessories to the lower and upper arm

Use this procedure to attach the lifting accessories.

Valid for variants IRB 6700 - 235/2.65, IRB 6700 - 205/2.80, IRB 6700 - 175/3.05, IRB 6700 - 150/3.20, IRB 6700 - 200/2.60, IRB 6700 - 155/2.85.

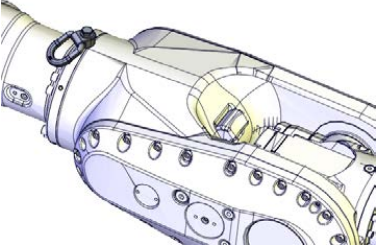
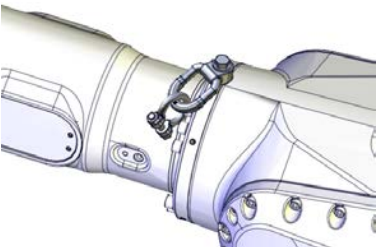



	Action	Note
1	 <p>CAUTION</p> <p>The lower and upper arms together weigh (according to variants) 510 kg. All lifting accessories used must be sized accordingly!</p>	
2	Fit a lifting eye to the wrist.	<p>Lifting eye: 3HAC16131-1</p>  <p>xx1200001133</p>
3	Fit a lifting shackle in the wrist lifting eye.	<p>Lifting shackle: SA-10-8-NA1</p>  <p>xx1200001234</p>

Continues on next page

4 Repair

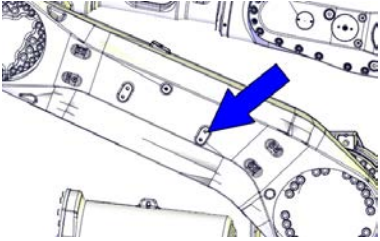
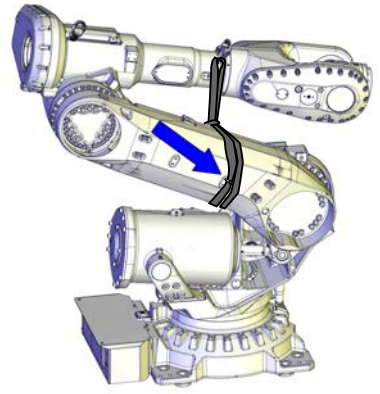
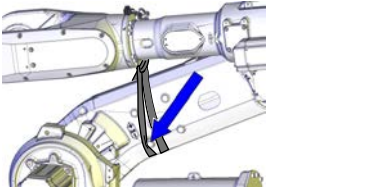
4.3.3 Attaching lifting accessories to an un-separated lower and upper arm (IRB 6700-235/2.65, -205/2.80, -175/3.05, -150/3.20, -200/2.60, -155/2.85)

Continued

	Action	Note
4	<p>Insert a M8x50 securing screw, not more than 10-15 mm, into the screw hole shown in the figure. This is done to secure the roundsling from gliding when lifting.</p> <p>If DressPack cable package is installed: use the ball joint housing instead, in the same way.</p>	 <p>xx1200001251</p>
5	<p>Run a roundsling around the lower arm, beneath the securing screw.</p> <p>If DressPack cable package is installed: place the roundsling beneath the ball joint housing on the outside of the lower arm instead.</p>	<p>Roundsling, 1.5 m: Length: 1.5 m. Lifting capacity: 2,000 kg.</p>  <p>xx1200001252</p>
6	<p>Adjust the roundsling on the other side of the lower arm, so that the roundsling runs on the left side of the most lower of the four bosses.</p> <p>This will prevent the roundsling from gliding.</p>	
7	<p>Attach the roundsling to the shackle on the wrist.</p>	 <p>xx1200001253</p>
8	<p>Stretch the roundsling between the wrist and the lower arm by slowly jogging the axis-3.</p> <p> Note</p> <p>Make sure the roundsling is stretched, in order to carry the weight of the lower arm.</p>	
9	<p> DANGER</p> <p>Turn off all:</p> <ul style="list-style-type: none"> • electric power supply • hydraulic pressure supply • air pressure supply <p>to the robot, before entering the robot working area.</p>	

Continues on next page

4.3.3 Attaching lifting accessories to an un-separated lower and upper arm (IRB 6700-235/2.65, -205/2.80, -175/3.05, -150/3.20, -200/2.60, -155/2.85)

Continued

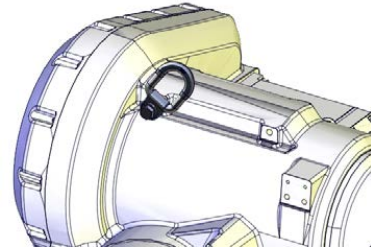
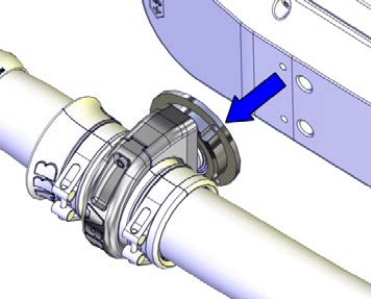
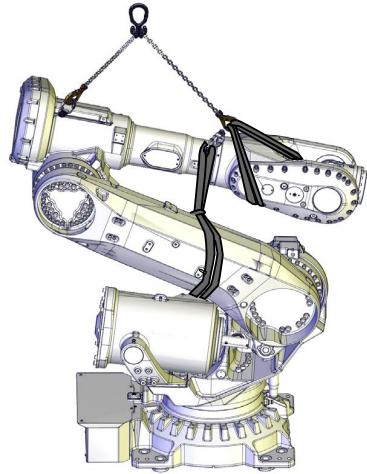
	Action	Note
10	<p>Fit a lifting eye in the arm house, with a fender washer underneath.</p>  <p>xx1400002196</p>	<p>Lifting eye: 3HAC16131-1 Fender washer: Outer diameter: minimum 26 mm, maximum 30 mm, hole diameter: 13 mm, thickness: 3 mm.</p>  <p>xx1200001134</p>
11	<p>If the robot is equipped with DressPack, unscrew the attachment screws of the bracket that holds the ball joint housings on the wrist. The DressPack can stay fitted in the ball joint housing.</p>	 <p>xx1400000355</p>
12	<p>Move the DressPack cable package over to the other side of where the lifting accessory will be attached to the shackle on the arm house.</p>	
13	<p>Attach the Lifting accessory (chain) to an overhead crane (or similar), then to the lifting eye in the arm house and to a roundsling run through the wrist.</p>	<p>Lifting accessory (chain): 3HAC15556-1 Roundsling, 1 m: Length: 1 m, lifting capacity: 1,000 kg.</p>  <p>xx1200001254</p>
14	<p>Raise the overhead crane to stretch the chains and roundslings. Verify that the roundsling between the wrist and the lower arm is stretched.</p>	

Continues on next page

4 Repair

4.3.3 Attaching lifting accessories to an un-separated lower and upper arm (IRB 6700-235/2.65, -205/2.80, -175/3.05, -150/3.20, -200/2.60, -155/2.85)

Continued

	Action	Note
15	To release the brake, connect the 24 VDC power supply. Connect to connector R2.MP2, axis-2 motor: <ul style="list-style-type: none">• + = pin 2• - = pin 5	

4.3.4 Attaching lifting accessories to an un-separated lower and upper arm (IRB 6700 -300/2.70, -245/3.00)

4.3.4 Attaching lifting accessories to an un-separated lower and upper arm (IRB 6700 -300/2.70, -245/3.00)

Validity of this section - IRB 6700 -300/2.70, -245/3.00

**Note**

Some sections have similar titles. Make sure to use the correct section, to find information about a certain IRB 6700 variant.

This section describes how to attach lifting accessories to variants IRB 6700 -300/2.70, -245/3.00

How to attach lifting accessories to variants IRB 6700 -235/2.65, -205/2.80, -175/3.05, -150/3.20, -200/2.60, -155/2.85 see section 4.3.3 *Attaching lifting accessories to an unseparated lower and upper arm.*

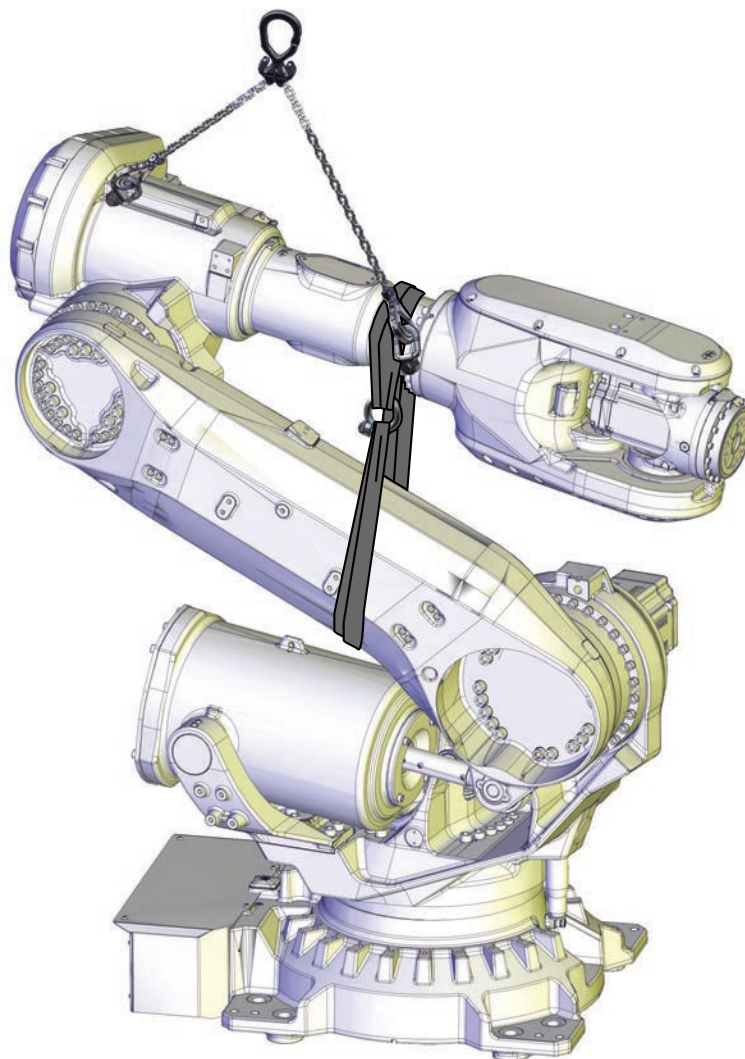
Attachment points of lifting accessory

xx1400002104

Continues on next page

4 Repair

4.3.4 Attaching lifting accessories to an un-separated lower and upper arm (IRB 6700 -300/2.70, -245/3.00)

Continued

Required tools

Equipment, etc.	Article number	Note
Lifting eye	3HAC16131-1	M12
Lifting eye	3HAC16131-1	M12
Fender washer	-	Outer diameter: minimum 26 mm, maximum 30 mm, hole diameter: 13 mm, thickness: 3 mm.
Lifting shackle	-	SA-10-8-NA1
Roundsling, 1.5 m	-	Length: 1.5 m. Lifting capacity: 2,000 kg.
Roundsling, 1 m	-	Length: 1 m, lifting capacity: 1,000 kg.
Lifting accessory (chain)	3HAC15556-1	Lifting instruction 3HAC15880-2 enclosed.
Standard toolkit	-	Content is defined in section Standard toolkit on page 814 .

Attaching lifting accessories to the lower and upper arm

Robot position

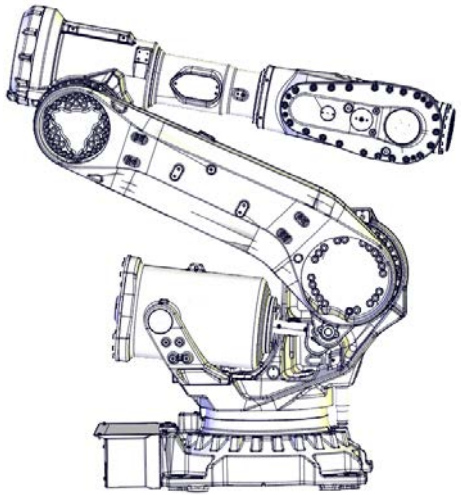
Action	Note
<p>1</p> <p> Note</p> <p>When jogging the axis-2 into position check that the balancing device ear and the ear on the lower arm is not colliding!</p>	
<p>2</p> <p>Jog the robot into position:</p> <ul style="list-style-type: none"> • Axis 1: position the axis 1 to be able to put down the arm system after removal • Axis 2: -60° • Axis 3: +70° (approximately) • Axis 4: +90° • Axis 5: 0° (-90° if DressPack is installed) • Axis 6: 0° (+90° if DressPack is installed) 	 <p>xx1200001250</p>

Continues on next page



4.3.4 Attaching lifting accessories to an un-separated lower and upper arm (IRB 6700 -300/2.70, -245/3.00)

Continued

	Action	Note
3	 DANGER Turn off all: <ul style="list-style-type: none"> • electric power supply • hydraulic pressure supply • air pressure supply to the robot, before entering the safe-guarded space.	

Attaching lifting accessories to the lower and upper arm

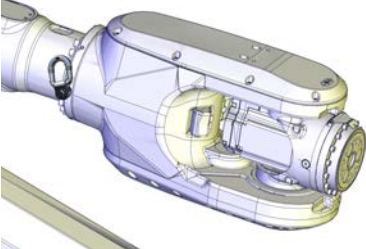
Use this procedure to attach the lifting accessories.



	Action	Note
1	 CAUTION The lower and upper arms together weigh (according to variants) 650 kg. All lifting accessories used must be sized accordingly!	
2	Fit a lifting eye to the wrist.	Lifting eye: 3HAC16131-1  xx1400002106
3	In order to secure the roundsling from gliding when lifting: <ul style="list-style-type: none"> • <i>With no DressPack cable package installed:</i> Insert a M12x50 securing screw, not more than 10-15 mm, into the screw hole shown in the figure. • <i>With DressPack cable package installed:</i> Use the ball joint housing in the same way. 	 xx1200001251

Continues on next page

4 Repair

4.3.4 Attaching lifting accessories to an un-separated lower and upper arm (IRB 6700 -300/2.70, -245/3.00)

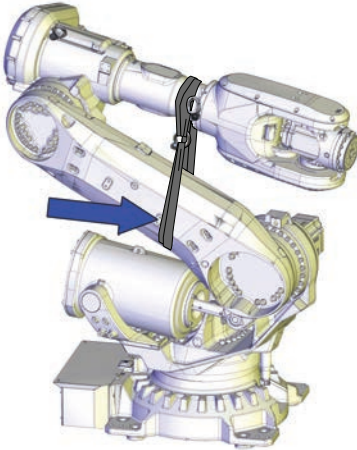
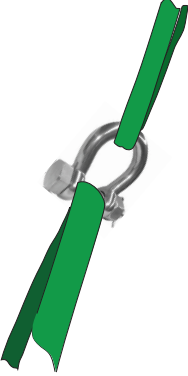
Continued

	Action	Note
4	<p>Run a roundsling around the lower arm, place it accordingly:</p> <ul style="list-style-type: none"> • <i>With no DressPack cable package installed:</i> Place the roundsling beneath the securing screw. • <i>With DressPack cable package installed:</i> Place the roundsling beneath the ball joint housing on the outside of the lower arm. 	<p>Roundsling, 2.5 m: Length: 2.5 m. Lifting capacity: 2,000 kg.</p>  <p>xx1400002105</p>
5	Run the roundsling up and over the upper arm.	
6	Connect both ends of the roundsling with a shackle.	 <p>xx1400000729</p>
7	<p>Stretch the roundsling between the upper and the lower arm by slowly jogging the axis-3.</p> <p> Note</p> <p>Make sure the roundsling is stretched, in order to carry the weight of the lower arm.</p>	
8	<p> DANGER</p> <p>Turn off all:</p> <ul style="list-style-type: none"> • electric power supply • hydraulic pressure supply • air pressure supply <p>to the robot, before entering the robot working area.</p>	

Continues on next page

4.3.4 Attaching lifting accessories to an un-separated lower and upper arm (IRB 6700 -300/2.70, -245/3.00)

Continued

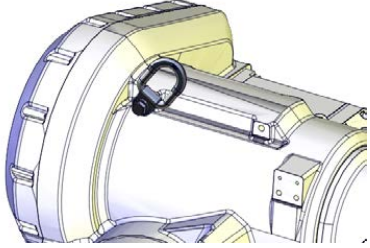
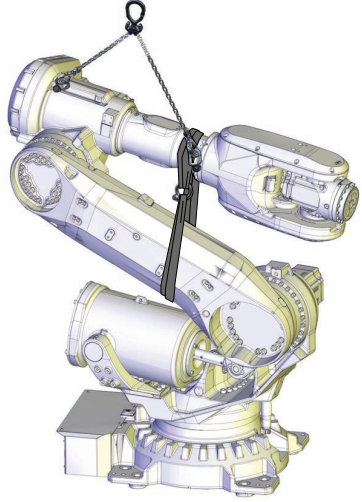
	Action	Note
9	<p>Fit a lifting eye in the arm house, with a fender washer underneath.</p>  <p>xx1400002196</p>	<p>Lifting eye: 3HAC16131-1 Fender washer: Outer diameter: minimum 26 mm, maximum 30 mm, hole diameter: 13 mm, thickness: 3 mm.</p>  <p>xx1200001134</p>
10	<p>Attach the Lifting accessory (chain) to an overhead crane (or similar), then to the lifting eye in the arm house and to the lifting eye in the wrist.</p>	<p>Lifting accessory (chain): 3HAC15556-1</p>  <p>xx1400002104</p>
11	<p>Raise the overhead crane to stretch the chains and roundslings. Verify that the roundsliding between the wrist and the lower arm is stretched.</p>	
12	<p>To release the brake, connect the 24 VDC power supply. Connect to connector R2.MP2, axis-2 motor:</p> <ul style="list-style-type: none"> • + = pin 2 • - = pin 5 	

4 Repair

4.3.5 Attaching lifting accessories to the upper arm

4.3.5 Attaching lifting accessories to the upper arm

Attachment points of lifting accessory

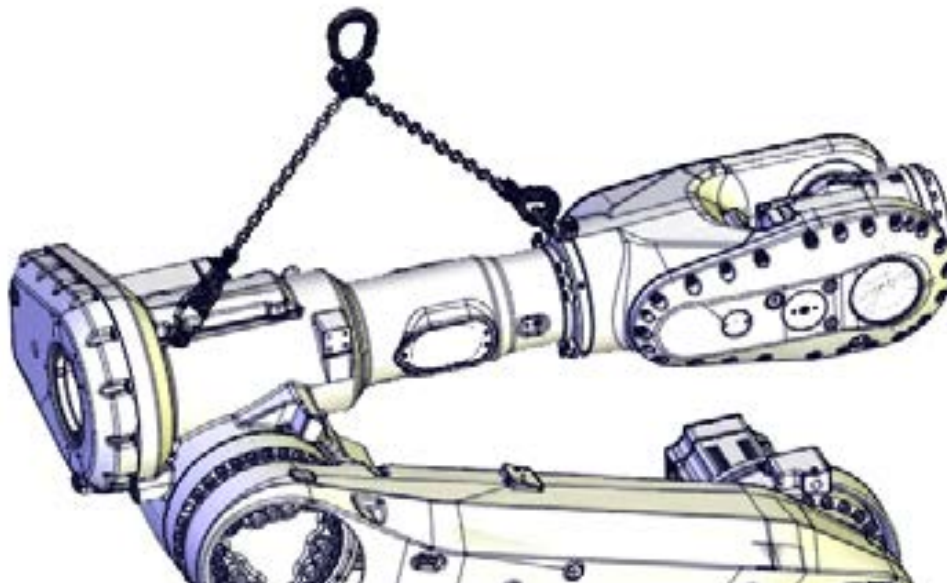

xx1200001308

Required equipment

Equipment, etc.	Article number	Note
Lifting eye	3HAC16131-1	M12
Lifting eye	3HAC16131-1	M12
Fender washer	-	Outer diameter: minimum 26 mm, maximum 30 mm, hole diameter: 13 mm, thickness: 3 mm.
Lifting accessory (chain)	3HAC15556-1	Lifting instruction 3HAC15880-2 enclosed.
Standard toolkit	-	Content is defined in section Standard toolkit on page 814 .

Continues on next page

Robot position

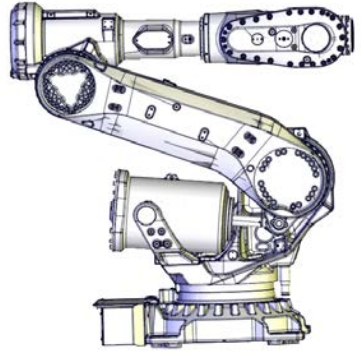
	Action	Note
1	<p>Jog the robot to the position:</p> <ul style="list-style-type: none"> • Axis-1: no significance • Axis-2: -65° • Axis-3: +65° • Axis-4: 0° • Axis-5: no significance • Axis-6: no significance 	 <p>xx1200001255</p>

Attaching lifting accessories

Attaching the lifting accessories to the upper arm

Use this procedure to attach the lifting accessories to the upper arm.

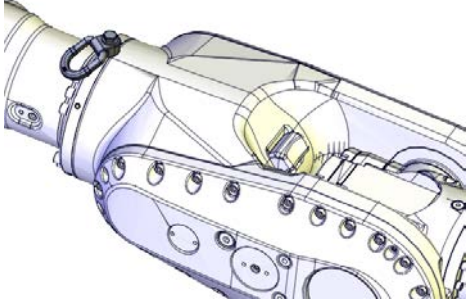

	Action	Note
1	 CAUTION <p>The weight of the complete upper arm (including the wrist) is 360 kg (IRB 6700 -235/2.65, -205/2.80, -175/3.05, -150/3.20, -200/2.60, -155/2.85) 465 kg (IRB 6700 -300/2.70, -245/3.00) All lifting accessories used must be sized accordingly.</p>	
2	<p>Fit a lifting eye to the wrist.</p>	<p>Lifting eye: 3HAC16131-1</p>  <p>xx1200001133</p>

Continues on next page

4 Repair

4.3.5 Attaching lifting accessories to the upper arm

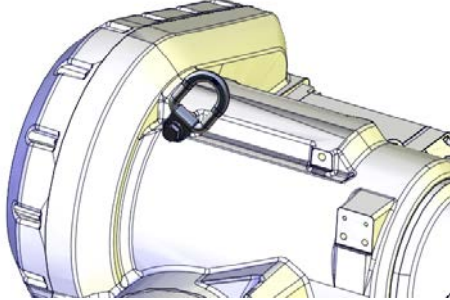
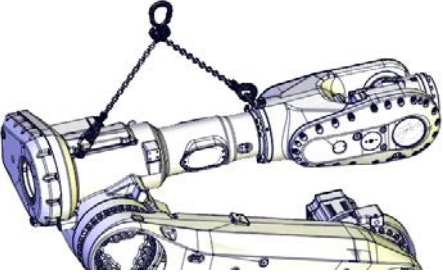
Continued

	Action	Note
3	<p>Fit a lifting eye in the arm house, with a fender washer underneath.</p>  <p>xx1400002196</p>	<p>Lifting eye: 3HAC16131-1 Fender washer: Outer diameter: minimum 26 mm, maximum 30 mm, hole diameter: 13 mm, thickness: 3 mm.</p>  <p>xx1200001134</p>
4	<p>Attach the upper arm lifting accessory (chain) to an overhead crane (or similar) and then to the lifting eye in the arm house and in the wrist.</p>	<p>Lifting accessory (chain): 3HAC15556-1</p>  <p>xx1200001308</p>
5	<p>Raise the lifting accessories to take the weight of the upper arm.</p>	
6	<p>In case of necessary adjustments, use the shortening loops on the lifting accessory (chain) to find the level position.</p>	 <p>xx1400002197</p>

4.4 Complete robot

4.4.1 Removing the cable harness

Location of the cable harness

The cable harness is located as shown in the figure.

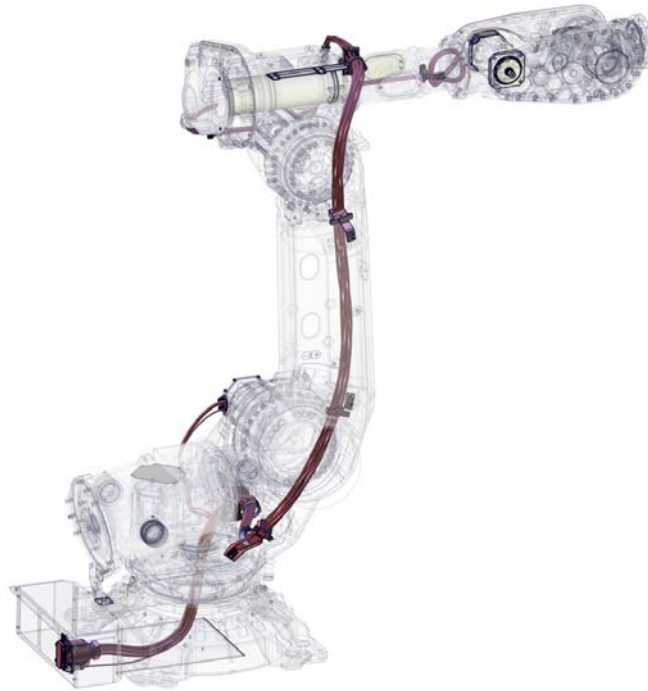

xx1300001096

Required tools and equipment

Equipment, etc.	Article number	Note
Standard toolkit	-	Content is defined in section Standard toolkit on page 814 .



Continues on next page

4 Repair

4.4.1 Removing the cable harness

Continued

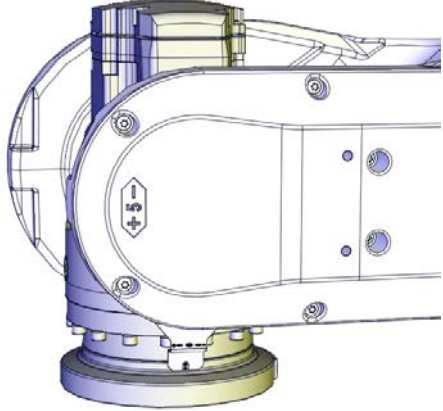
Preparations before removing the cable harness

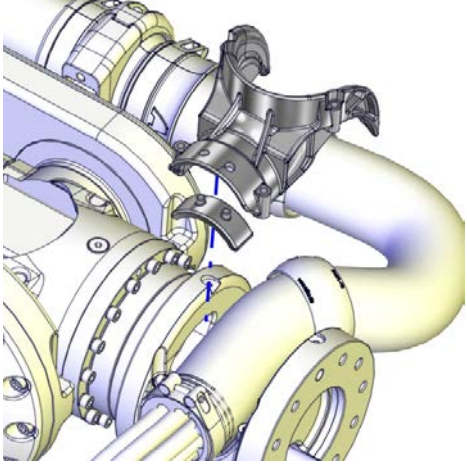
	Action	Note
1	<p>Jog the robot to the specified position:</p> <ul style="list-style-type: none"> • Axis 1: 0° • Axis 2: -60° • Axis 3: +60° • Axis 4: 0° • Axis 5: +90° • Axis 6: No significance. <p> Note</p> <p>The specified position is a recommended position.</p> <p>Axis-5 must be oriented as close as possible to +90° to be able to open the axis-6 motor cover and to remove the axis-6 motor cables, and in order to avoid the spiral of the cable harness in the carrier, being unwound or placed in the wrong position.</p> <p>Depending on what tool is used, the other axes may need to be jogged to another position.</p>	 <p>xx1200001081</p>
2	<p> DANGER</p> <p>Turn off all:</p> <ul style="list-style-type: none"> • electric power supply • hydraulic pressure supply • air pressure supply <p>to the robot, before entering the safeguarded space.</p>	
3	<p> Note</p> <p>If only the manipulator harness shall be removed, the DressPack cable package can stay fitted on the process turning disk.</p>	 <p>xx1400000208</p>

Continues on next page

Removing the cable harness - upper arm and wrist

These procedures describe how to remove the cable harness in the upper arm and wrist.

Retrieving access to the wrist cabling

Use this procedure to remove the wrist cover to retrieve access to the axis-5 and axis-6 motor cables.

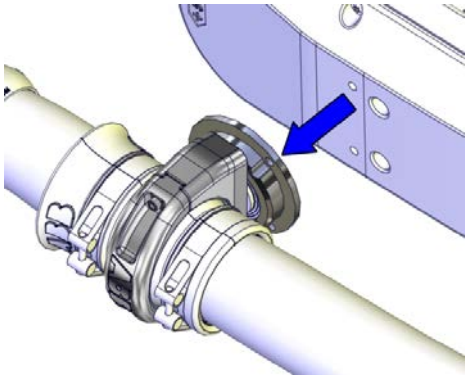
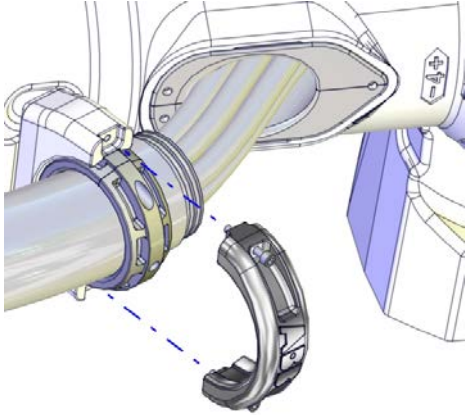
	Action	Note
1	 <p>DANGER</p> <p>Make sure that all supplies for electrical power, hydraulic pressure, and air pressure are turned off.</p>	
2	<p>If DressPack is installed:</p> <ul style="list-style-type: none"> Remove the bracket with the complete ball joint housing still fitted, as shown in the figure. <p>This is done to be able to reach the two hidden screws that secure the wrist cover.</p>	 <p>xx140000355</p>
3	<p>If used, open the ball joint housing on the arm tube and remove the DressPack cable package.</p>	 <p>xx140000206</p>

Continues on next page



4 Repair

4.4.1 Removing the cable harness

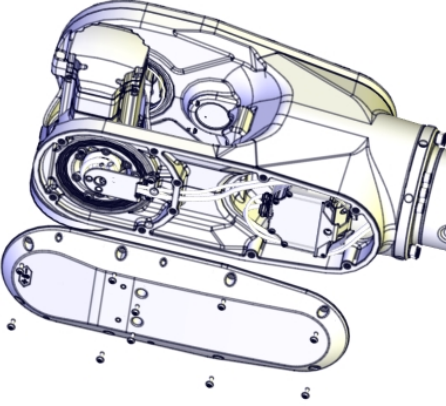
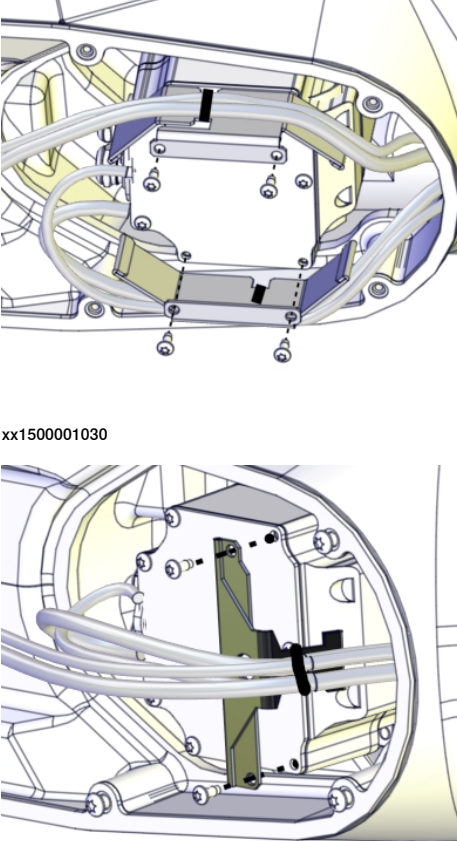
Continued

	Action	Note
4	Remove the wrist cover.	 <p data-bbox="943 745 1050 763">xx1300002247</p>
5	Remove the heat protection plate/plates from the motor with the cabling still attached to the plate. Remove the heat protection plates from the motor with the cabling still attached to the plate.	<p data-bbox="943 801 1401 913">There are two versions of the heat protection plates. Choose figure depending on which plate is installed on the robot.</p>  <p data-bbox="943 1346 1050 1364">xx1500001030</p> <p data-bbox="943 1787 1050 1805">xx1300000490</p>

Continues on next page

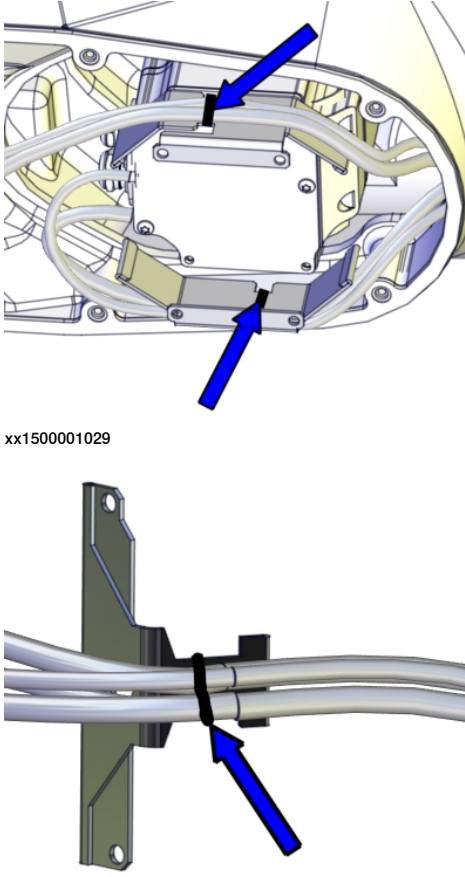
	Action	Note
6	<p>Cut the cable ties that hold the cable harness to the plate.</p> <p> Note</p> <p>Keep the heat protection plate until refitting.</p> <p> Tip</p> <p>If removing the plate only for replacing the motor, the cabling does not need to be loosened from the plate.</p>	<p>Choose figure depending on which plate is installed on the robot.</p>  <p>xx1500001029</p> <p>xx1300000489</p>

Disconnecting the axis-6 motor cables

	Action	Note
1	<p> DANGER</p> <p>Make sure that all supplies for electrical power, hydraulic pressure, and air pressure are turned off.</p>	

Continues on next page

4 Repair

4.4.1 Removing the cable harness

Continued

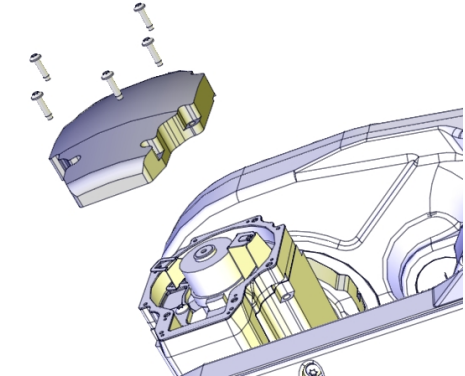
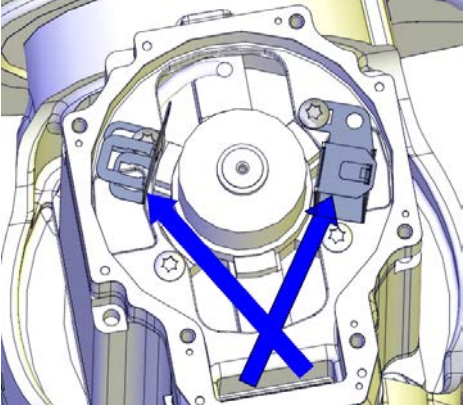
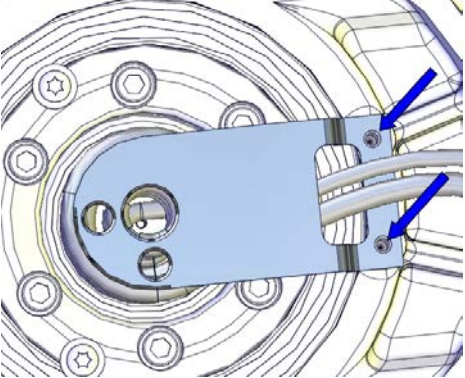
	Action	Note
2	Unscrew the attachment screws and remove the motor cover.	 <p>xx1200001080</p>
3	Disconnect the motor cables.	 <p>xx1300000488</p>
4	Unscrew the attachment screws that hold the cable bracket.	 <p>xx1300000484</p>

Continues on next page

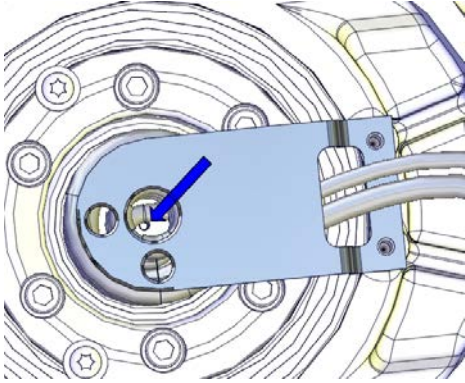
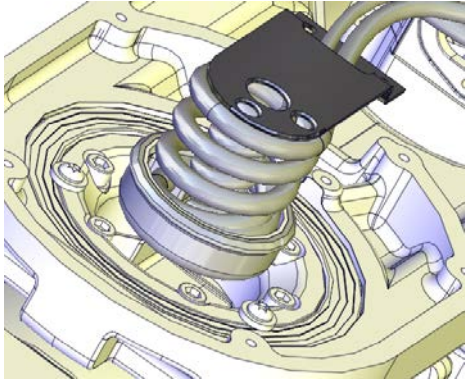
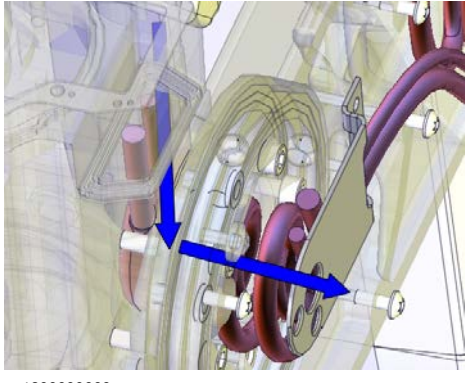
	Action	Note
5	<p>Unscrew the M4 screw that holds the carrier.</p> <p> Note</p> <p>The screw is located at the bottom of the carrier.</p>	 <p>xx130000485</p>
6	<p>Pull out the carrier from its position.</p>	 <p>xx1300001113</p>
7	<p>Pull out the axis-6 motor cables by holding the cables with one hand at the motor and the other at the carrier.</p>	 <p>xx130000666</p>

Disconnecting the axis-5 motor cables

	Action	Note
1	<p> DANGER</p> <p>Make sure that all supplies for electrical power, hydraulic pressure, and air pressure are turned off.</p>	

4 Repair

4.4.1 Removing the cable harness

Continued

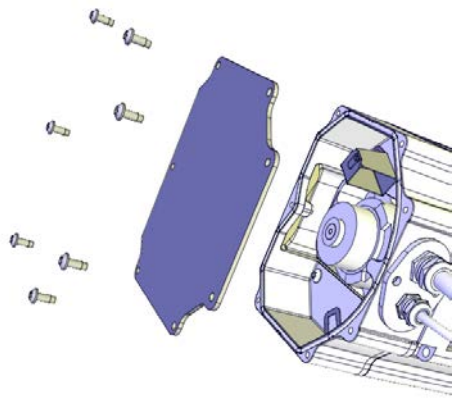
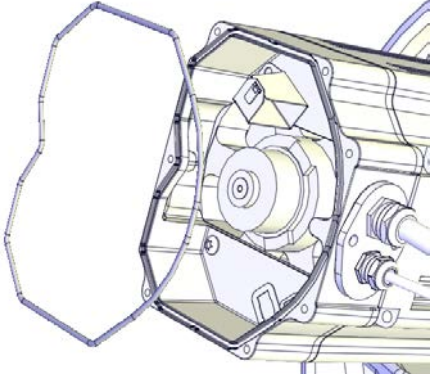
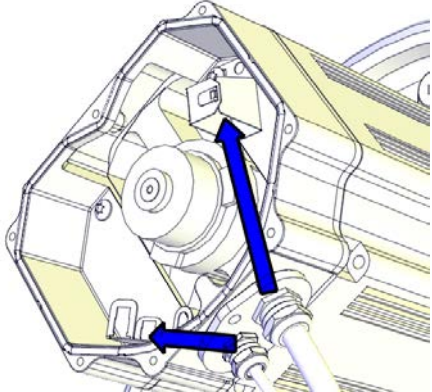
	Action	Note
2	Unscrew the attachment screws and washers and remove the motor cover.	 xx1200001135
3	Make sure the o-ring is present.	 xx1200001070
4	Disconnect the motor cables.	 xx1200001066

Continues on next page

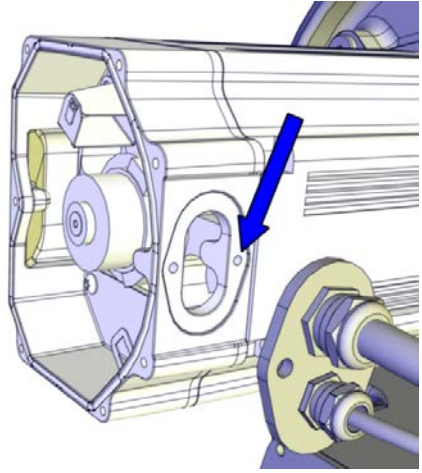
	Action	Note
5	<p>Remove the cable gland cover by performing the following steps:</p> <ol style="list-style-type: none"> 1 Open the inner screw a little (the one the arrow is pointing at). No need to remove this screw from the motor. 2 Remove the outer screw. 3 Slide the cable gland cover away from the inner screw. Make sure the gasket is not damaged. <p> Tip</p> <p>Make a note in which direction the cable exit hole is facing, if the motor will be removed too. The motor shall be refitted in the same position.</p>	 <p>xx1300000656</p>
6	Use caution and pull out the motor cables.	

Disconnecting the axis-3 and axis-4 motor cables

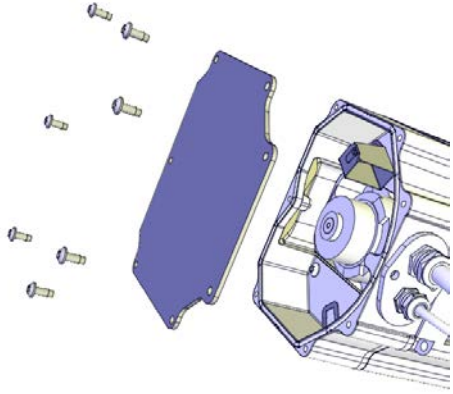

	Action	Note
1	<p> DANGER</p> <p>Make sure that all supplies for electrical power, hydraulic pressure, and air pressure are turned off.</p>	
2	Unscrew the attachment screws and washers and remove the motor cover.	 <p>xx1200001135</p>

Continues on next page

4 Repair

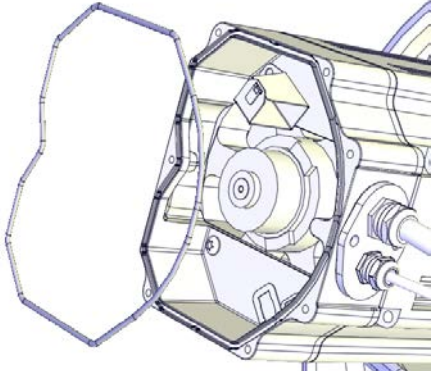
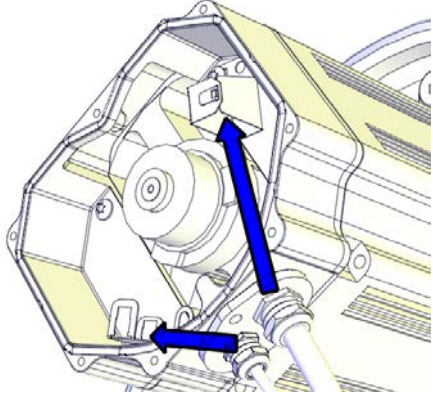

4.4.1 Removing the cable harness

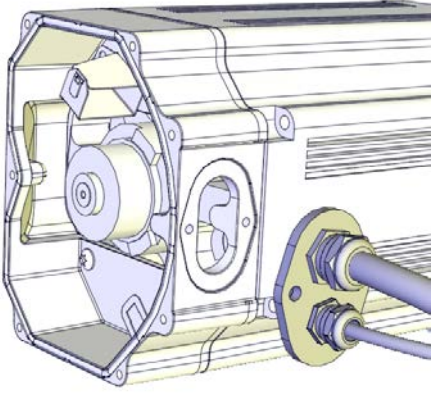
Continued

	Action	Note
3	Make sure the o-ring is present.	 xx1200001070
4	Disconnect the motor cables.	 xx1200001066
5	Remove the cable gland cover. Make sure the gasket is not damaged.  Tip Make a note in which direction the cable gland hole is facing, if the motor will be removed too. The motor shall be refitted in the same position.	 xx1200001067
6	Use caution and pull out the motor cables.	

Continues on next page

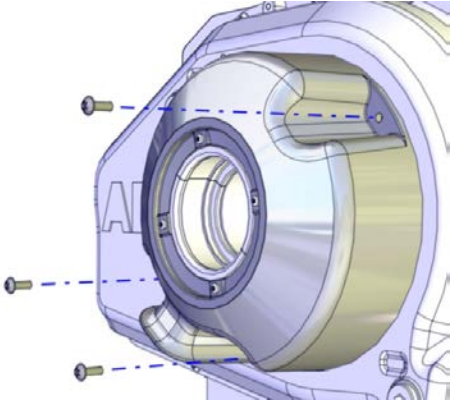
Removing the cable harness - wrist and upper arm

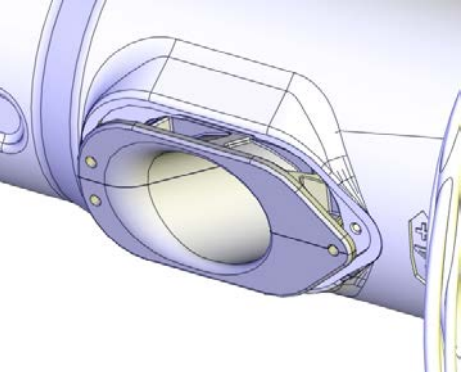

	Action	Note
1	<p>Remove the cover.</p> <p> Note</p> <p><i>Foundry Plus:</i> Use caution not to damage the gasket, not to loose the washers on the cover sealing or not to loose the inserts fitted on the cover.</p>	 <p>xx120000045</p>
2	<p>If the cabling is to be replaced by a new cable harness, remove the cover insert to use it on the new cabling.</p>	 <p>xx1700001803</p>
3	<p>If used, loosen the insert.</p>	 <p>xx1700000690</p>

Continues on next page

4 Repair

4.4.1 Removing the cable harness

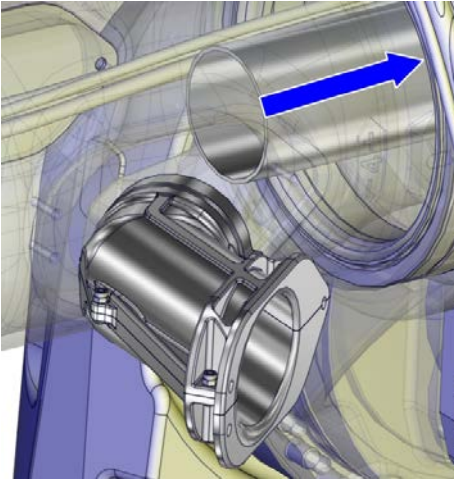
Continued

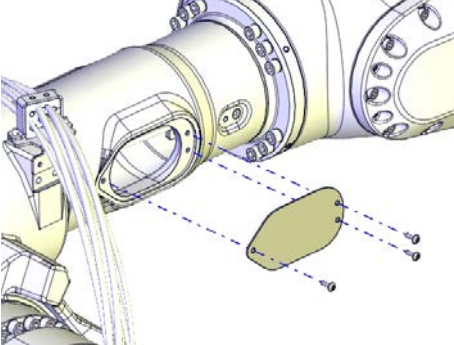
	Action	Note
4	If used, push the DressPack tube a little backwards.	 <p>xx140000720</p>
5	 Tip Use tape and tie the axis-5 and axis-6 connectors and carrier into a bundle (if not already done). This is done to facilitate the removal and to avoid damaging the parts. This will also make it easier to run the cable harness through the inside of the upper arm.	 <p>xx130000668</p>
6	Remove the side cover on the arm tube.	 <p>xx130000557</p>

Continues on next page

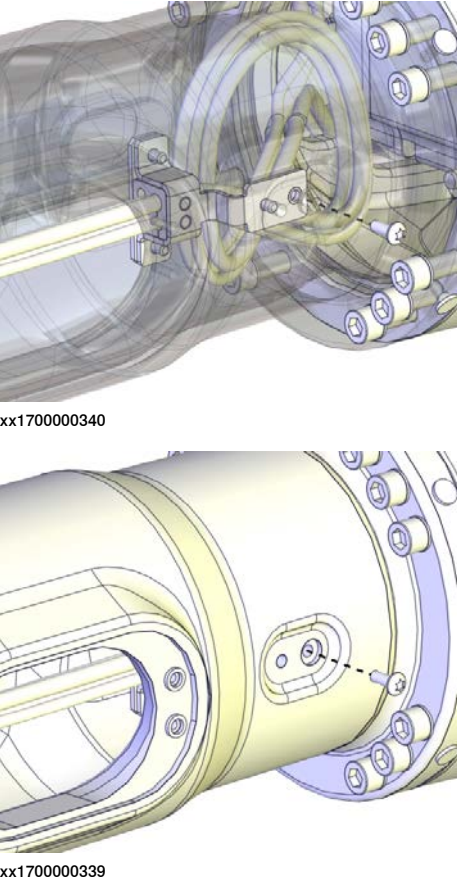
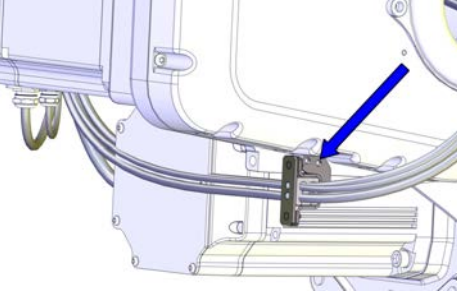
	Action	Note
7	<p>Unscrew the attachment screw that secures the axis-4 metal clamp inside the arm tube.</p> <p> Note</p> <p>The screw is reached from outside the upper arm.</p>	 <p>xx170000340</p> <p>xx170000339</p>
8	<p>Remove the arm house metal clamp.</p>	 <p>xx130000543</p>

Continues on next page



4 Repair

4.4.1 Removing the cable harness

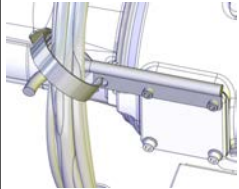
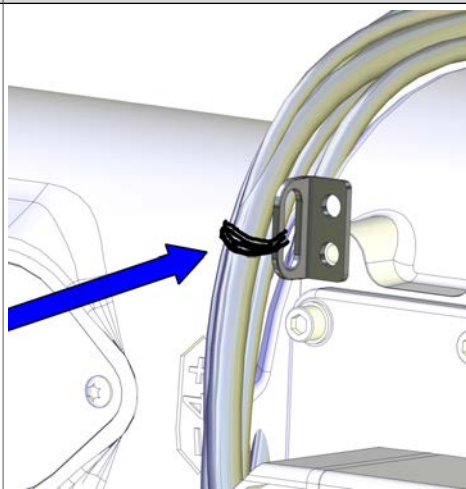
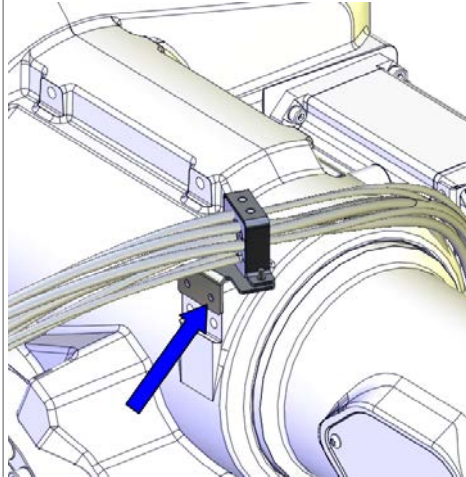
Continued

	Action	Note
9	<p>Cut the cable tie at the cable fixing bracket.</p> <p> Note</p> <p>If DressPack is fitted, the cable fixing bracket is replaced by the cable guide.</p>  <p>xx1300001973</p> <p>Cable guide.</p>	 <p>xx1300000544</p> <p>Cable fixing bracket.</p>
10	<p>Remove the metal clamp on top of the arm house.</p>	 <p>xx1300000541</p>

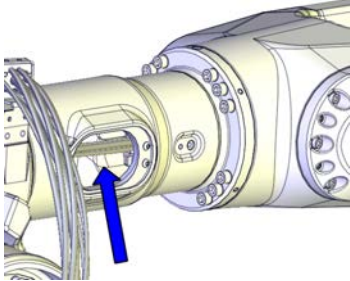
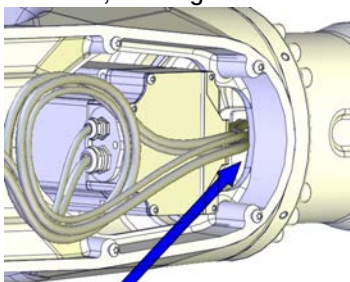
Continues on next page

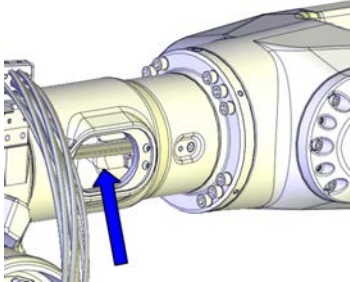
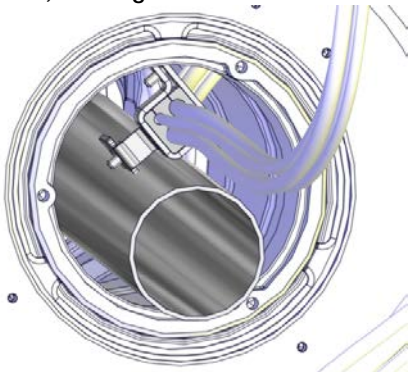
	Action	Note
11	<p>Remove the cable harness out from the wrist.</p> <p> Tip</p> <p>This step is best performed by two persons working together:</p> <ul style="list-style-type: none"> • Person 1: Put one hand inside the side hole and take a hold of the cable harness. • Person 2: Take a hold on the cable harness inside the wrist. • Together: Move the cable harness past the axis-5 motor and into the arm tube. 	<p>Person 1, working at the side hole:</p>  <p>xx130000745</p> <p>Person 2, working at the wrist:</p>  <p>xx130000746</p>
12	<p>Remove the cable harness out of the arm tube, at the back of the upper arm.</p> <p> Tip</p> <p>This step is best performed by two persons working together:</p> <ul style="list-style-type: none"> • Person 1: Put one hand inside the side hole and take a hold of the cable harness. • Person 2: Take a hold on the cable harness at the back of the robot. • Together: Move the cable harness out of the arm tube. <p> Note</p> <p>To be able to remove the cable harness with the DressPack tube fitted, the tube needs to be pulled out a little, then be placed on the lower left side in the arm tube and the bracket of the cable harness then needs to be placed on the upper right hand side.</p> <p>(This is not needed on variants IRB 6700 - 300/2.70, -245/3.00)</p>	<p>Person 1, working at side hole:</p>  <p>xx130000745</p> <p>Person 2, working at the back:</p>  <p>xx140002561</p>

Continues on next page

4 Repair

4.4.1 Removing the cable harness

Continued



Removing the cable harness - base, frame and lower arm

These procedures describes how to remove the cable harness from base, frame and lower arm.

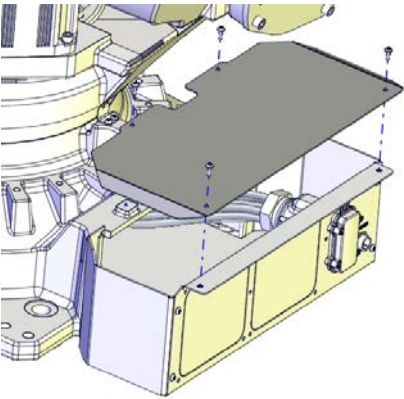
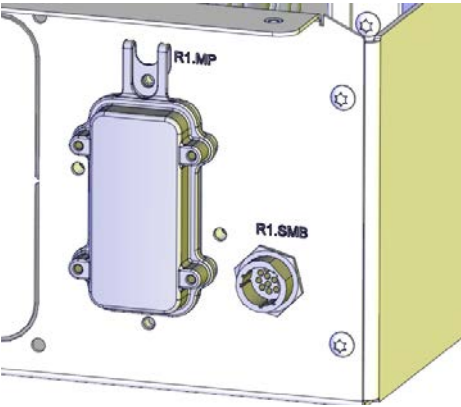
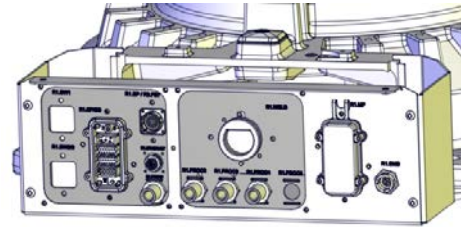
Preparations before removing the cable harness in the base

	Action	Note
1	 DANGER Make sure that all supplies for electrical power, hydraulic pressure, and air pressure are turned off.	
2	Remove the base cover.	 xx1300000561
3	Disconnect connectors: <ul style="list-style-type: none">• R1.MP• R1.SMB	 xx1300000591
4	If used, disconnect the DressPack hoses in the base.	 xx1400000366

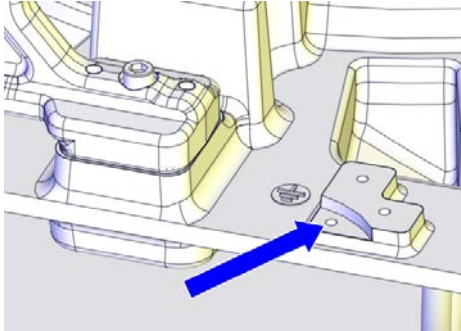
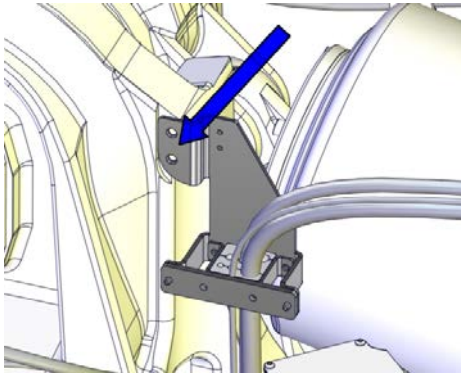
Continues on next page

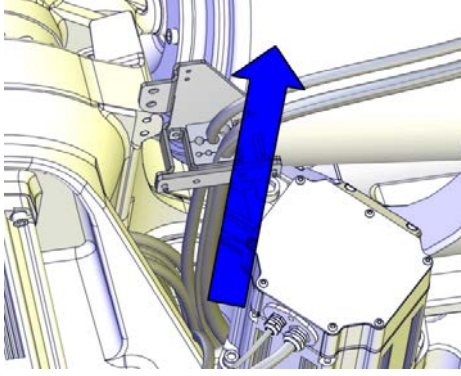
	Action	Note
5	Disconnect the earth cable.	<p>Screw dimension : M6x16 Washer dimension : 6.4x17x3</p>  <p>xx140000354</p>
6	<p>If used, remove the attachment screws that secure the bracket. This is done to facilitate removal of the DressPack hoses.</p>	 <p>xx140000078</p>
7	<p>If used, use caution and pull out the DressPack hoses through the protection tube in the base.</p> <p> Note</p> <p>There is no need to pull out the DressPack cables at this point!</p>	 <p>xx140000088</p>

4 Repair

4.4.1 Removing the cable harness

Continued

Removing the axis-1 motor protection plates

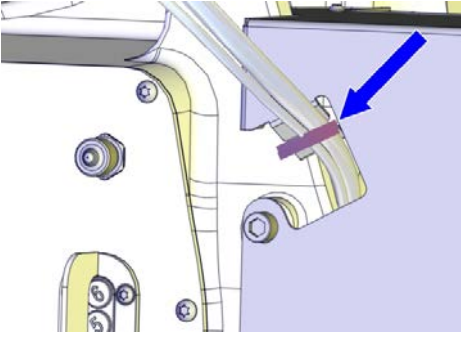
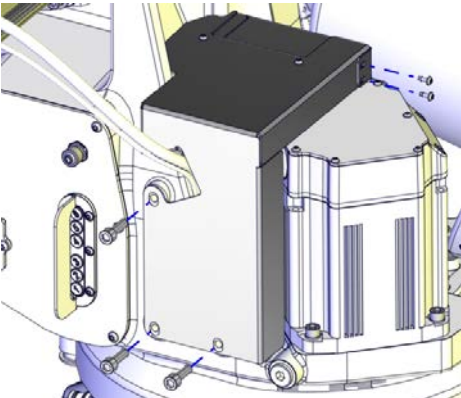
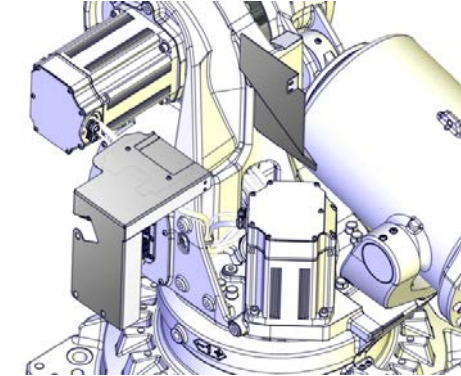
	Action	Note
1	<p><i>Foundry Plus.</i> Cut the cable tie that hold the axis-1 and axis-2 motor cables on the protection plates.</p>	 <p>xx140000722</p>
2	<p><i>Foundry Plus.</i> Disassemble the protection plates by removing five of the attachment screws (three M10x30 and two of the M5x12 screws).</p>	 <p>xx140000723</p>
3	<p><i>Foundry Plus.</i> Remove the two protection plates.</p>	 <p>xx140000724</p>

Disconnecting the axis-1 and axis-2 motor cables

	Action	Note
1	<p> DANGER Make sure that all supplies for electrical power, hydraulic pressure, and air pressure are turned off.</p>	

Continues on next page

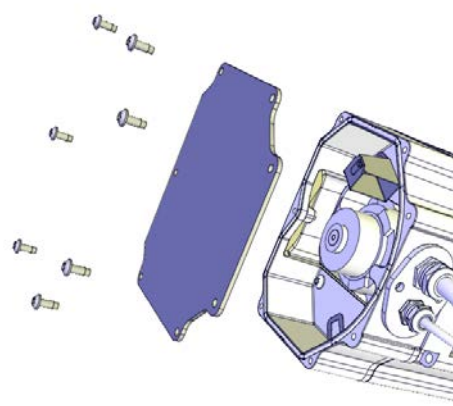
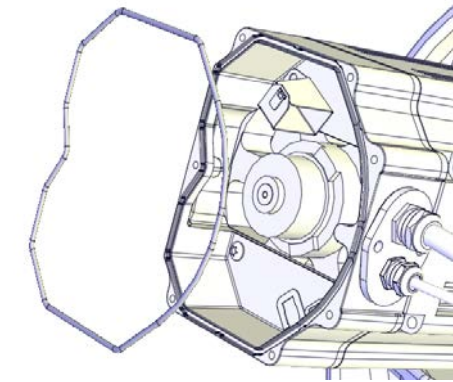
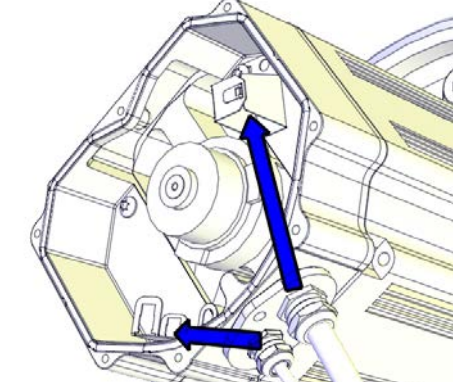
	Action	Note
2	Unscrew the attachment screws and washers and remove the motor cover.	 <p>xx1200001135</p>
3	Make sure the o-ring is present.	 <p>xx1200001070</p>
4	Disconnect the motor cables.	 <p>xx1200001066</p>



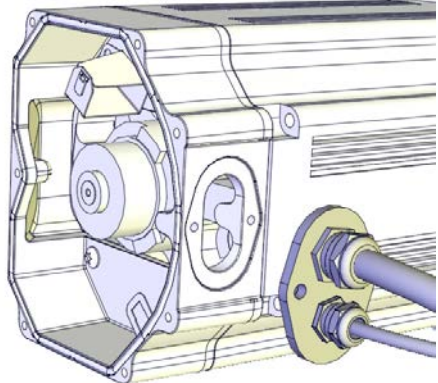

4 Repair

4.4.1 Removing the cable harness

Continued

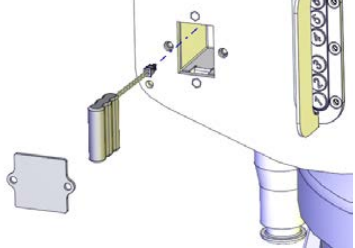

	Action	Note
5	<p>Remove the cable gland cover. Make sure the gasket is not damaged.</p> <p> Tip</p> <p>Make a note in which direction the cable gland hole is facing, if the motor will be removed too. The motor shall be refitted in the same position.</p>	 <p>xx1200001067</p>
6	Use caution and pull out the motor cables.	

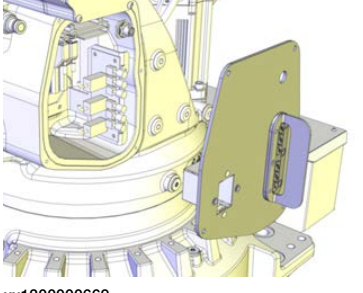
Preparations before disconnecting the SMB unit

	Action	Note
1	<p> DANGER</p> <p>Make sure that all supplies for electrical power, hydraulic pressure, and air pressure are turned off.</p>	
2	<p> ELECTROSTATIC DISCHARGE (ESD)</p> <p>The unit is sensitive to ESD. Before handling the unit please read the safety information in the section The unit is sensitive to ESD on page 55</p>	
3	Open the small cover on the SMB cover, disconnect the battery cable and remove the battery.	 <p>xx1300000829</p>
4	<p>Remove the SMB cover.</p> <p> CAUTION</p> <p>Clean cover from metal residues before opening. Metal residues can cause shortage on the boards which can result in hazardous failures.</p>	 <p>xx1300000669</p>

Continues on next page

Disconnecting the brake release unit

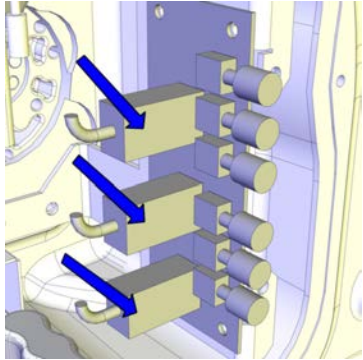
	Action	Note
1	 DANGER Make sure that all supplies for electrical power, hydraulic pressure, and air pressure are turned off.	
2	 ELECTROSTATIC DISCHARGE (ESD) The unit is sensitive to ESD. Before handling the unit please read the safety information in the section <i>The unit is sensitive to ESD on page 55</i>	
3	Take a picture or make notes of how the robot cabling is positioned in regard to the brake release board.	
4	Remove the connectors X8, X9 and X10 from the brake release board.	 xx130000670

Removing the cable harness in the base

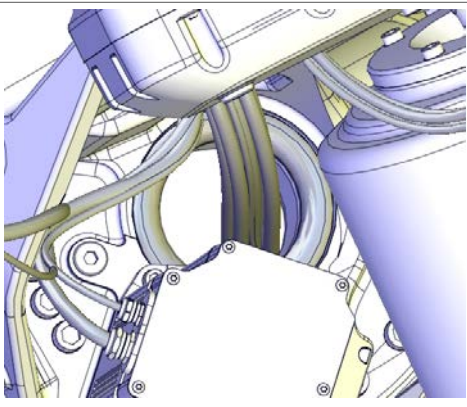
	Action	Note
1	If equipped with DressPack, pull out the DressPack cables through the protection tube and place them carefully over the balancing device.	
2	Pull out the robot cable harness through the protection tube.	 xx130000732
3	Place the cable harness over the balancing device.	

Continues on next page

4 Repair



4.4.1 Removing the cable harness

Continued

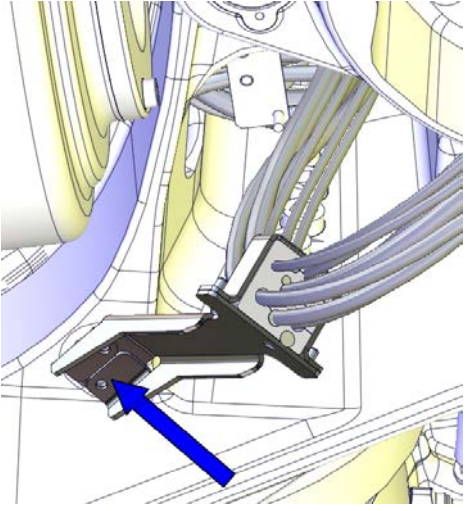
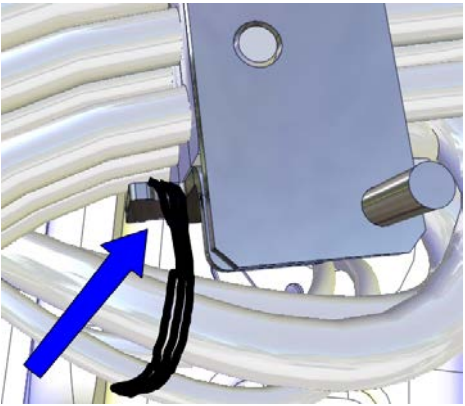
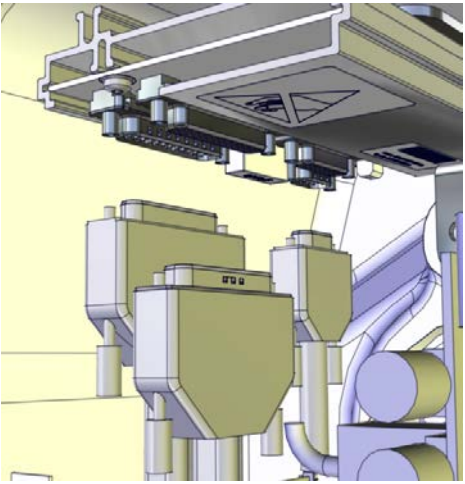
Removing the cable harness in the frame

	Action	Note
1	Unscrew the attachment screws that hold the metal clamp frame.	 xx130000542
2	Cut the cable tie inside the frame recess.	 xx120001237
3	Disconnect connectors on the SMB unit.	 xx1300001114

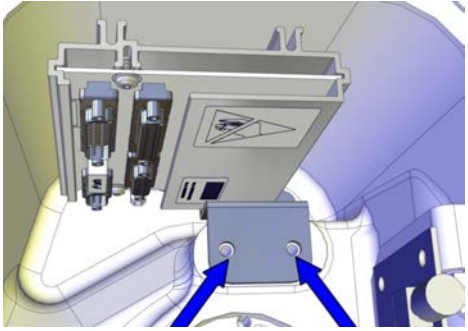
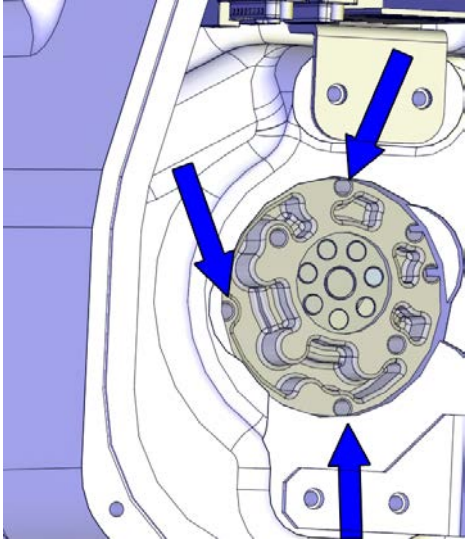
Continues on next page

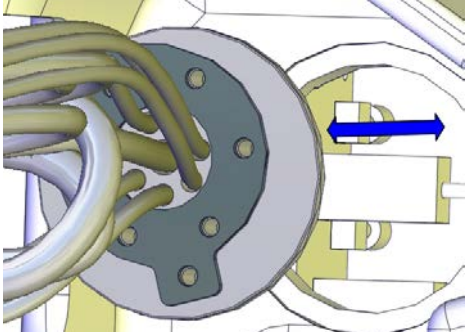
	Action	Note
4	<p>Unscrew the screws and washers that holds the bracket with the SMB unit, and remove the SMB unit.</p> <p>Put the SMB unit in an ESD bag until it shall be refitted.</p>	 <p>xx130000730</p>
5	<p>Unscrew the attachment screws that hold the SMB/BU cover from inside the SMB recess.</p>	 <p>xx130000655</p>
6	<p>Use caution and pull out the cable harness from the SMB recess.</p> <p> Note</p> <p>The parts are sealed with Sikaflex. Remove the part carefully.</p>	 <p>xx130000560</p>



4 Repair

4.4.1 Removing the cable harness

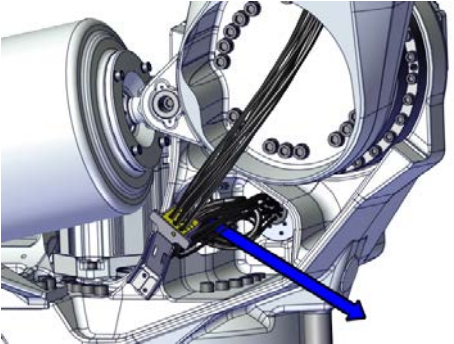
Continued

	Action	Note
7	<p>Use caution and pull out the cable harness through the hole in the frame.</p> <p> Tip</p> <p>Keep a hand on the cable protection while pulling out the cable harness from the base, so it does not come loose.</p>	 <p>xx1700001587</p>

Removing the cable harness in the lower arm

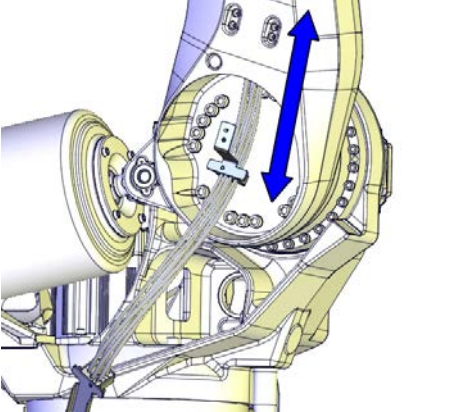
	Action	Note
1	<p>Loosen the axis-2 lower arm metal clamp and the axis-3 lower arm metal clamp located on the inside of the lower arm by removing the attachment screws.</p> <p> Note</p> <p>The screws are reached from the outside of the lower arm.</p>	 <p>xx1300000540</p>
2	<p>Use caution and pull the cable harness out.</p>	 <p>xx1300000733</p>

4.4.2 Refitting the cable harness

Location of the cable harness

The cable harness is located as shown in the figure.

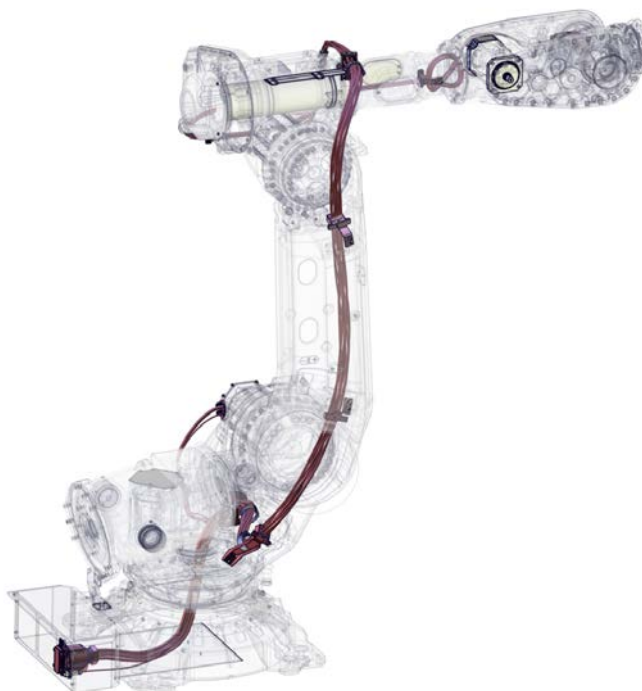

xx1300001096

Spare part

Spare part	Spare part number	Note
Cable harness	See <i>Product manual, spare parts - IRB 6700/IRB 6700Inv.</i> <i>Product manual, spare parts - IRB 6790</i>	
Cover insert	3HAC048520-001	Replace if damaged.
Cable protection, PU rubber	3HAC055411-001	Replace if damaged.

Required tools and equipment

Equipment, etc.	Article number	Note
Standard toolkit	-	Content is defined in section Standard toolkit on page 814 .

Consumables

Consumable	Article number	Note
Grease	3HAC042536-001	Shell Gadus S2 Used to lubricate o-rings.

Continues on next page

4 Repair

4.4.2 Refitting the cable harness

Continued

Consumable	Article number	Note
O-ring	21522012-429	D=84.5x3 Used on the SMB/BU cover.
O-ring ⁱ	3HAB3772-111 (circular profile) / 3HAC054692-002 (hexagon profile)	169.5x3 / 169.5x4.8x2.65 Used on axis-1 motor cover.
	3HAB3772-111 (circular profile) / 3HAC054692-002 (hexagon profile)	D=169.5x3 Used on axis-2 motor cover.
	3HAB3772-111 (circular profile) / 3HAC054692-002 (hexagon profile)	D=169.5x3 Used on axis-3 motor cover.
	3HAB3772-110 (circular profile) / 3HAC054692-001 (hexagon profile)	D=119x3 Used on axis-4 motor cover.
	3HAB3772-110 (circular profile) / 3HAC054692-001 (hexagon profile)	D=119x3 Used on axis-5 motor cover.
Gasket	3HAC033489-001/ 3HAC044252-001	Used on axis-6 motor cover.
Cable ties	-	
Weatherstrip	3HAC053986-001	

ⁱ The cross-section profile is either circular or hexagon. If only ordering the o-ring, order the same profile that is currently installed in the connection box.

Robot position

If the robot axes have been re-positioned after the cable harness has been removed, make sure to restore the initial robot position before refitting the cable harness. See [Preparations before removing the cable harness on page 220](#).



Refitting the cable harness - base, frame and lower arm

These procedures describes how to refit the cable harness in base, frame and lower arm.

Preparations before refitting the cable harness in the base, frame and lower arm

Action	Note
<p>1</p>  <p>DANGER</p> <p>Turn off all:</p> <ul style="list-style-type: none"> • electric power supply • hydraulic pressure supply • air pressure supply <p>to the robot, before entering the safeguarded space.</p>	

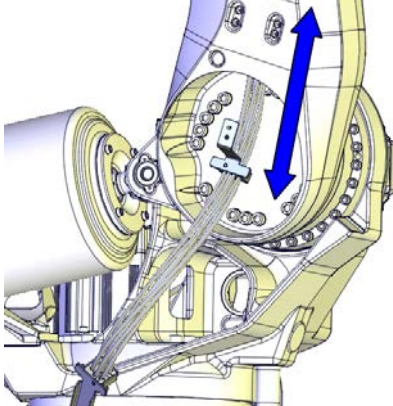
Continues on next page

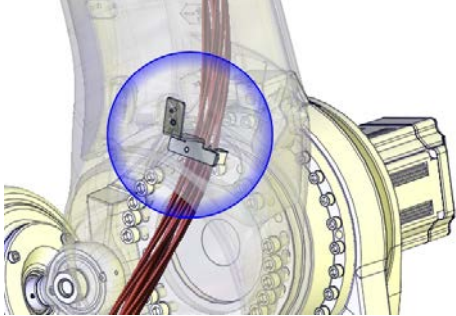
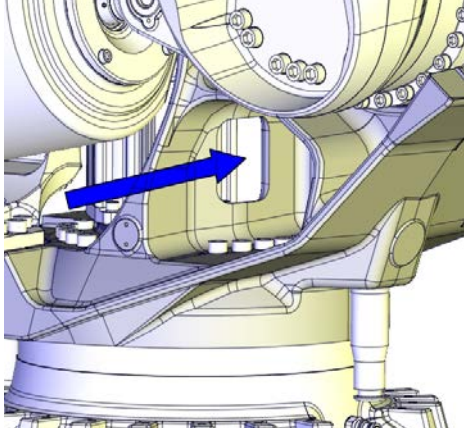
	Action	Note
2	<p>Tie the axis-5 and axis-6 connectors and carrier into a bundle with tape. This is done to facilitate the procedure and to avoid damaging the parts during the procedure. This will also make it easier to run the cable harness through the inside of the robot.</p>	 <p>xx130000668</p>
3	<p>Run the cable harness through the lower arm.</p>	 <p>xx130000733</p>
4	<p>Secure the axis-2 lower arm cable bracket.</p> <p> Note</p> <p>Do not secure the axis-3 lower arm cable bracket at this point.</p> <p> Note</p> <p>Screws are reached from the outside of the lower arm.</p>	 <p>xx130000734</p>
5	<p>Run the cable harness into the hole in the frame in this order:</p> <ul style="list-style-type: none"> • R1.MP • R1.SMB • R2.MP2 • R2.MP1 	 <p>xx130000735</p>

Continues on next page

4 Repair

4.4.2 Refitting the cable harness

Continued

Refitting the cable harness in the base

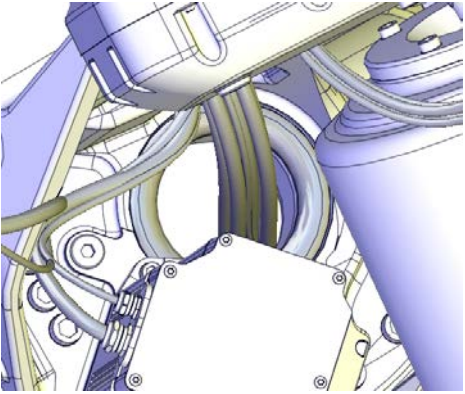
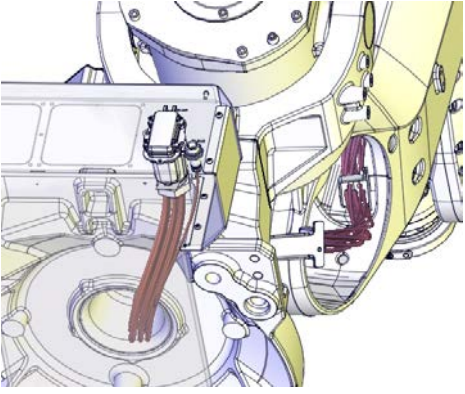
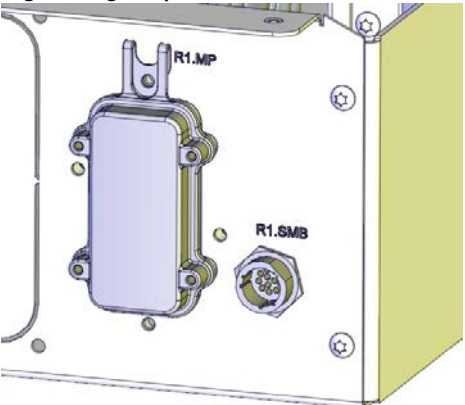
	Action	Note
1	<p>Run the cables through the protection tube in this order:</p> <ul style="list-style-type: none">• R1.MP• R1.SMB <p>If necessary, lubricate the cables with grease to make them run more smoothly.</p>	 <p>xx130000732</p>
2	<ul style="list-style-type: none">• Make sure that the cables are not twisted. Each cable must be in line with its position on the base plate.• Make sure that the R1.SMB cable will run on the correct side of the R1.MP1, see the figure.	 <p>xx130000736</p>
3	<p>Make sure that the markings on the cables are facing the base cover, when connected.</p>	
4	<p>Connect connectors R1.MP and R1.SMB.</p>	<p>Tightening torque for R1.SMB: 10 Nm.</p>  <p>xx130000591</p>

Continues on next page

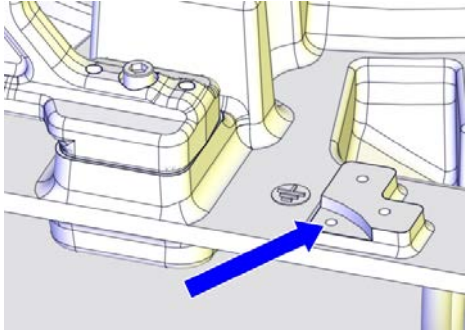
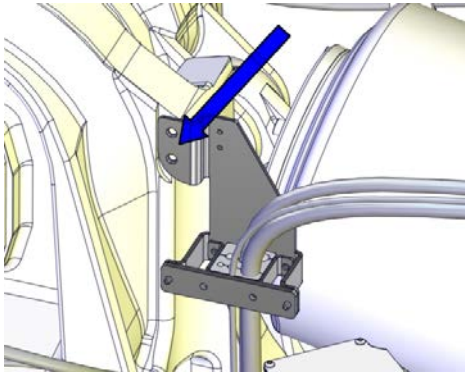
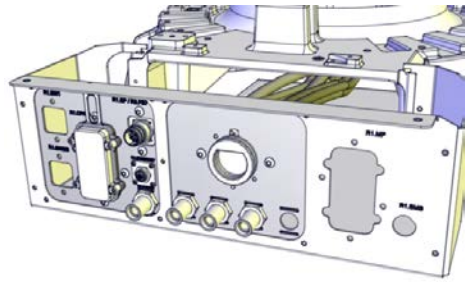
	Action	Note
5	Connect the earth cable.	<p>Screw dimension: M6x16. Washer dimension: 6.4x17x3.</p>  <p>xx1400000354</p>
6	If used, run the DressPack cables through the protection tube in the base.	
7	If used, run the DressPack hoses through the protection tube in the base. Make sure that the hoses are running correctly and are not twisted!	
8	If used, fit the bracket that hold the DressPack to the frame.	 <p>xx1400000078</p>
9	If used, connect the DressPack cable package on the base plate.	 <p>xx1200000052</p>

Continues on next page

4 Repair

4.4.2 Refitting the cable harness

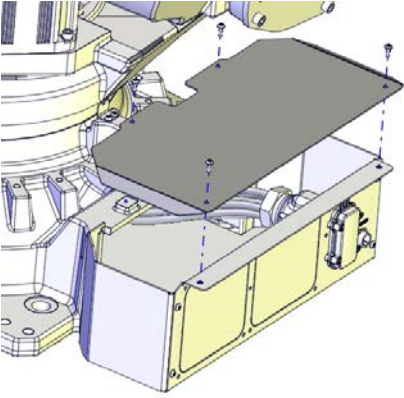

Continued

	Action	Note
10	Refit the base cover.	 <p data-bbox="943 719 1050 741">xx1300000561</p>

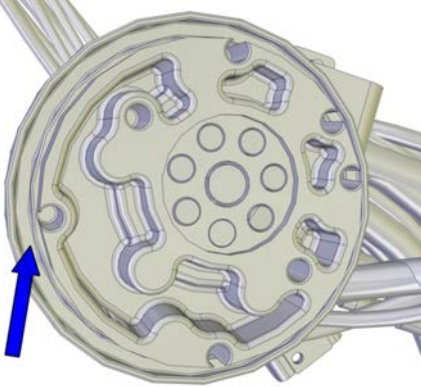
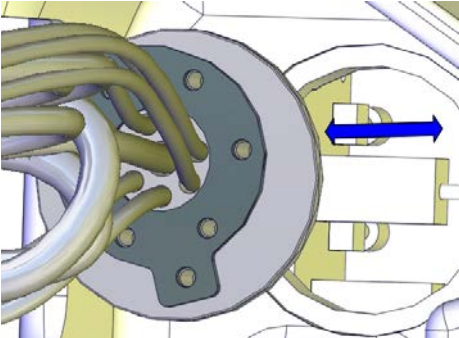
Refitting the cable harness in the frame

	Action	Note
1	Check the o-ring located on the SMB/BU cover. Replace if damaged.	<p data-bbox="943 887 1182 909">O-ring, 21522012-429</p>  <p data-bbox="943 1335 1050 1357">xx1300000737</p> <p data-bbox="943 1368 1404 1402">The figure shows the position of the o-ring.</p>
2	Wipe clean the contact surfaces of the cover as well as the hole it shall fit in.	
3	Apply Sikaflex on the o-ring before assembly.	
4	Run the SMB/BU cables into the SMB recess.	 <p data-bbox="943 1906 1050 1928">xx1300000560</p>

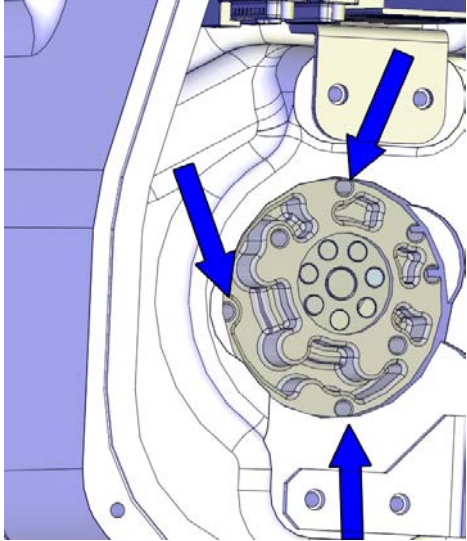
Continues on next page

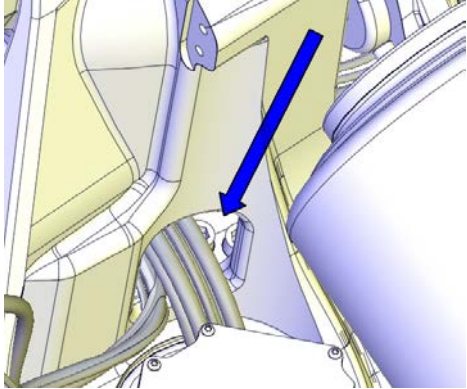
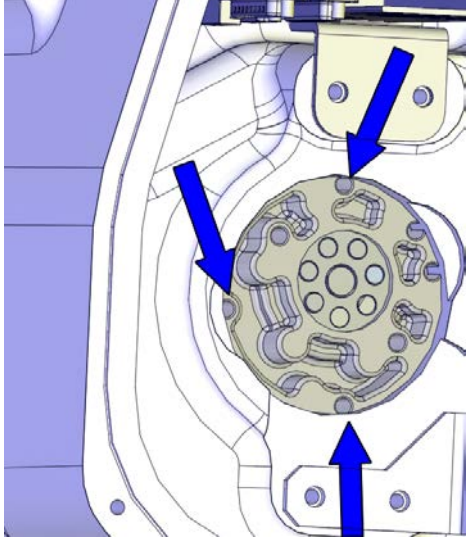
	Action	Note
5	<p>Fit the SMB/BU cover in its hole with the attachment screws from inside the SMB recess without damaging the o-ring.</p> <p> Note</p> <p>Do not tighten the screws fully! It must still be possible to adjust the position of the cable harness by rotating the SMB/BU cover in its hole a little.</p>	<p>Screws: 3 pcs.</p>  <p>xx130000655</p>
6	<p>Adjust the cables running through the hole in the frame by carefully moving the SMB/BU cover on its screws, while at the same time checking the position of the cable harness through the hole.</p> <p> Note</p> <p>The cables must be placed so that they don't rub against any part of the robot.</p>	 <p>xx130000593</p>
7	<p>Secure the SMB/BU cover with its three attachment screws from inside the SMB/BU recess.</p>	 <p>xx130000655</p>

Continues on next page



4 Repair

4.4.2 Refitting the cable harness

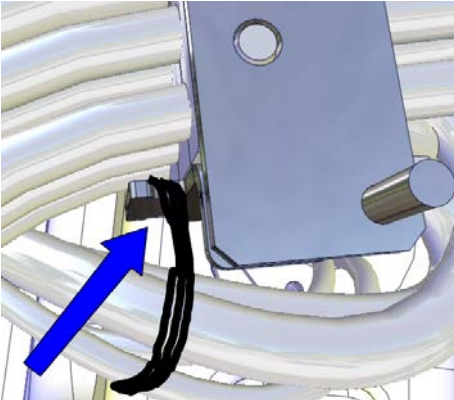
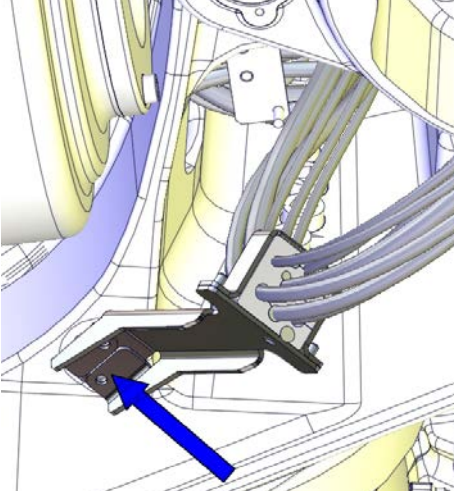
Continued

	Action	Note
8	Secure the cable harness to the bracket inside the frame hole, with a cable tie.	 <p>xx1200001237</p>
9	Refit the frame metal clamp.	 <p>xx1300000542</p>

Refitting and reconnecting the SMB and BU units

	Action	Note
1	 <p>DANGER</p> <p>Make sure that all supplies for electrical power, hydraulic pressure, and air pressure are turned off.</p>	
2	 <p>ELECTROSTATIC DISCHARGE (ESD)</p> <p>The unit is sensitive to ESD. Before handling the unit please read the safety information in the section The unit is sensitive to ESD on page 55</p>	

Continues on next page

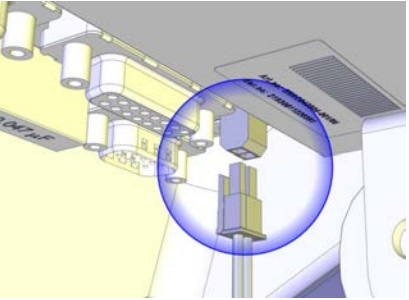
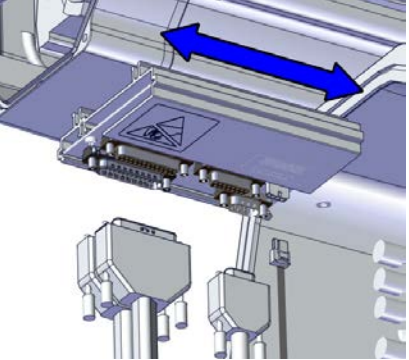
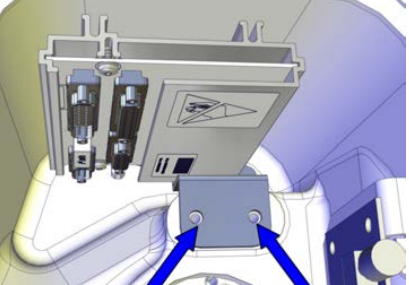
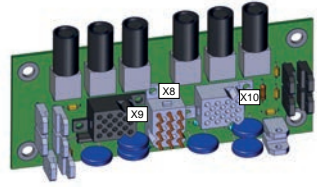
	Action	Note
3	<p>Connect the battery cable to the SMB unit. Make sure the lock snaps into place during refitting.</p>	 <p>xx1300000729</p>
4	<p>Connect all connectors to the SMB board:</p> <ul style="list-style-type: none"> • R1.SMB1-3, R1.SMB4-6 and R2.SMB 	 <p>xx1300000728</p>
5	<p>Push the SMB unit carefully into position and fit the bracket that secures the SMB unit.</p>	 <p>xx1300000730</p>
6	<p>If disconnected, reconnect the connectors X8, X9 and X10 to the brake release board. Be careful not to damage the sockets or pins. Make sure the connector and its locking arms are snapped down properly.</p>	 <p>xx1700000978</p>

Continues on next page

4 Repair

4.4.2 Refitting the cable harness

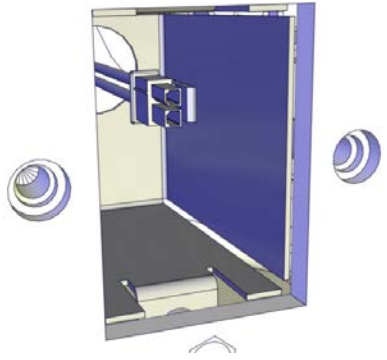
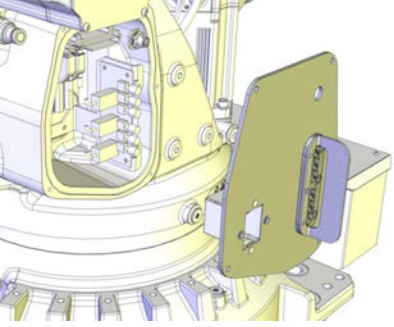

Continued

	Action	Note
7	Pull out the battery cable through the recess for the battery.	 <p>xx130000834</p>
8	Secure the SMB cover with the attachment screws. If cabling is used for 7th axis (option), refit the connector R2.FB7 to the SMB cover and tighten with 6 Nm.	 <p>xx130000669</p>

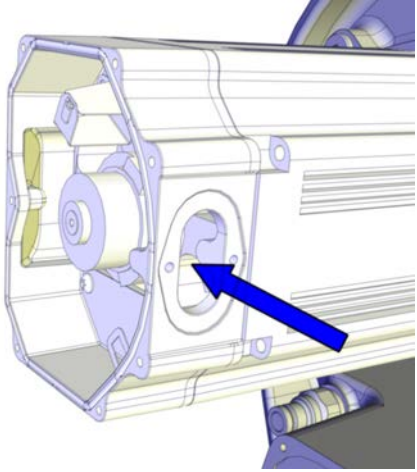
Reconnecting the axis-1 and axis-2 motor cables

	Action	Note
1	Push the motor cables through the cable gland opening.	 <p>xx130000738</p>

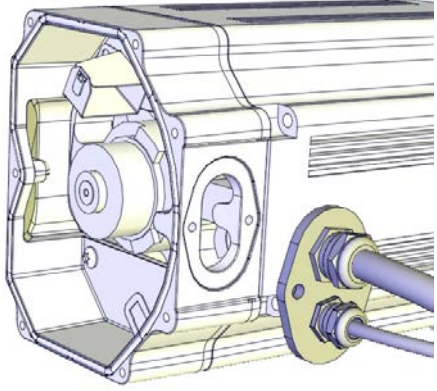
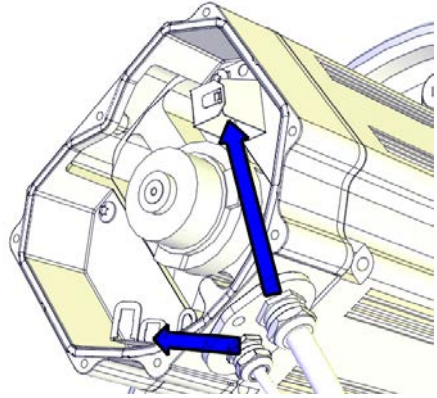
Continues on next page

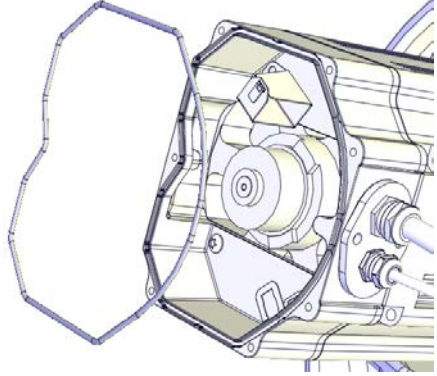



	Action	Note
2	<p>Refit the cable gland cover.</p> <p> Note Replace the gasket if damaged.</p>	 <p>xx1200001067</p>
3	<p>Connect the motor cables.</p> <p>Connect in accordance with the markings on the connectors.</p>	 <p>xx1200001066</p>
4	<p>Inspect the o-ring.</p> <p> Note Replace if damaged.</p>	<p>O-ring, axis-1: 3HAB3772-111 (circular profile) / 3HAC054692-002 (hexagon profile)</p> <p>O-ring, axis-2: 3HAB3772-111 (circular profile) / 3HAC054692-002 (hexagon profile)</p> <p>O-ring, axis-3: 3HAB3772-111 (circular profile) / 3HAC054692-002 (hexagon profile)</p> <p>O-ring, axis-4: 3HAB3772-110 (circular profile) / 3HAC054692-001 (hexagon profile)</p>  <p>xx1200001070</p>

Continues on next page



4 Repair

4.4.2 Refitting the cable harness

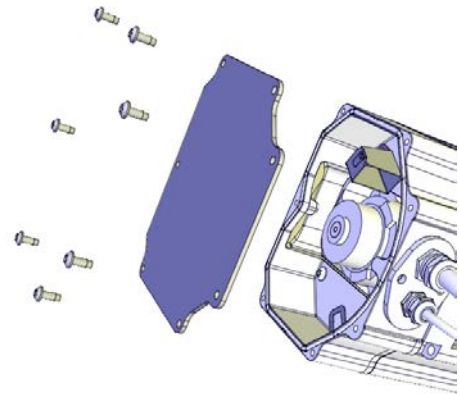

Continued

	Action	Note
5	Wipe clean o-ring and o-ring groove.	
6	Refit the o-ring.  Tip Lubricate the o-ring with some grease for a better fitting in the groove.	
7	 CAUTION When fitting the motor cover, make sure that none of the cables inside will be damaged.	
8	Refit the motor cover with it's attachment screws.  Note Do not reuse the self-threading attachment screws. Replace with standard attachment screws or the threads will be damaged.  Note Make sure the o-ring is undamaged and properly fitted.	Attachment screws: M5x12 8.8 (7 pcs)  xx1200001135
9	Make sure that the covers are tightly sealed.	

Refitting the cable harness - lower arm

	Action	Note
1	 Tip Use tape and tie the axis-5 and axis-6 connectors and carrier into a bundle (if not already done). This is done to facilitate the procedure and to avoid damaging the parts during the procedure. This will also make it easier to run the cable harness through the inside of the robot.	 xx1300000668

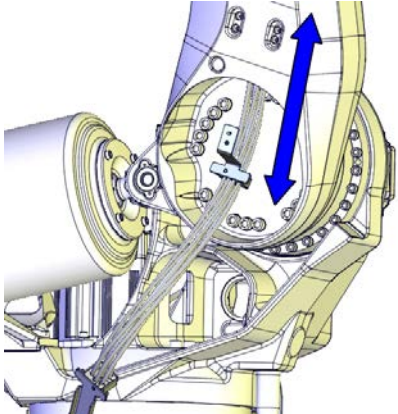
Continues on next page

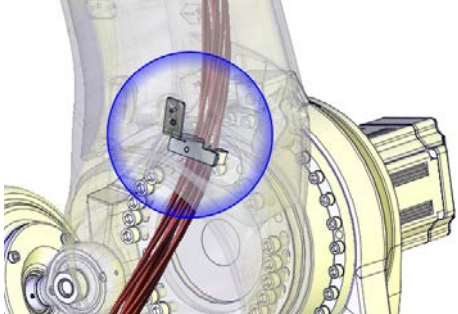
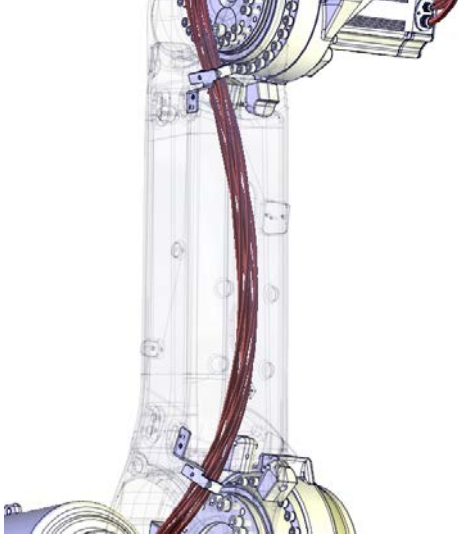
	Action	Note
2	Run the upper end of the cable harness up through the lower arm.	 <p>xx130000733</p>
3	Refit the axis-2 lower arm metal clamp located on the inside of the lower arm.  Note The screws are reached from the outside of the lower arm.	 <p>xx130000734</p>
4	Before fitting the remaining axis-3 lower arm cable bracket inside the lower arm, check that it will stay twisted a little between the metal clamps, after fitting, as shown in the figure. Do not change the position of the brackets!	 <p>xx130000595</p>

Continues on next page

4 Repair

4.4.2 Refitting the cable harness

Continued

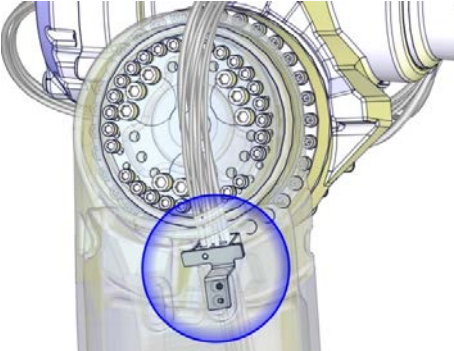
	Action	Note
5	<p>Refit the axis-3 lower arm metal clamp located on the inside of the lower arm.</p> <p> Note</p> <p>The screws are reached from the outside of the lower arm.</p>	 <p>xx130000558</p>



Refitting the cable harness - upper arm and wrist

These procedures describes how to refit the cable harness in upper arm and wrist.

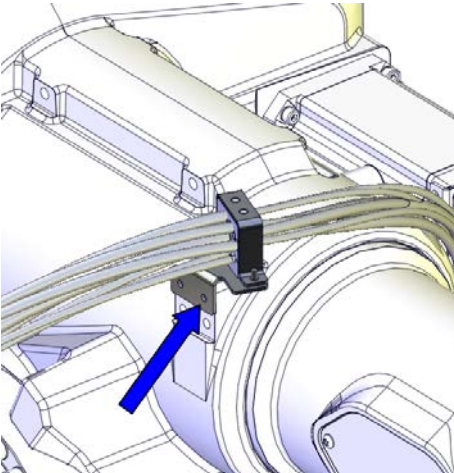
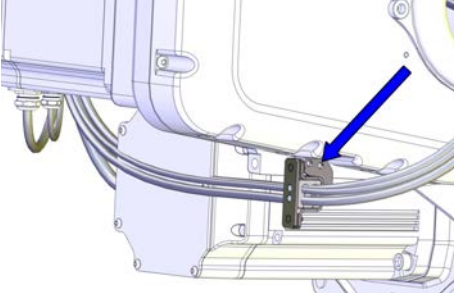
Refitting the cable harness - upper arm

	Action	Note
1	Refit the metal clamp on top of the arm house.	 <p>xx130000541</p>
2	Refit the arm house metal clamp.	 <p>xx130000543</p>
3	Arrange the cables between the cable clamps in the upper arm.	

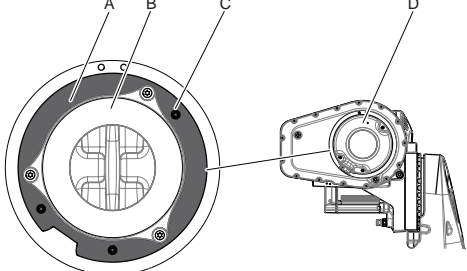

Continues on next page

	Action	Note
4	<p> Tip</p> <p>Use tape and tie the axis-5 and axis-6 connectors and carrier into a bundle (if not already done). This is done to facilitate the procedure and to avoid damaging the parts during the procedure.</p> <p>This will also make it easier to run the cable harness through the inside of the robot.</p>	 <p>xx1300000668</p>
5	<p>Foundry Plus:</p> <p>Make sure that the gasket underneath the cover is correctly fitted. Replace if damaged.</p> <p>The gasket is covered with adhesive on the side facing the upper arm cover. The three washers are pressed into the holes in the gasket. Make sure all three washers are fitted.</p>	 <p>xx1400000382</p> <ul style="list-style-type: none"> A Gasket B Cable guide C Washer D Cover



4 Repair

4.4.2 Refitting the cable harness

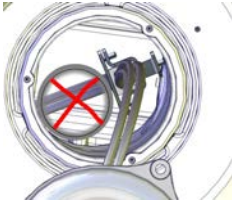
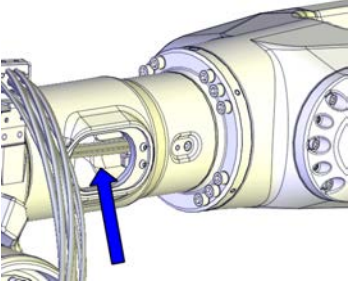
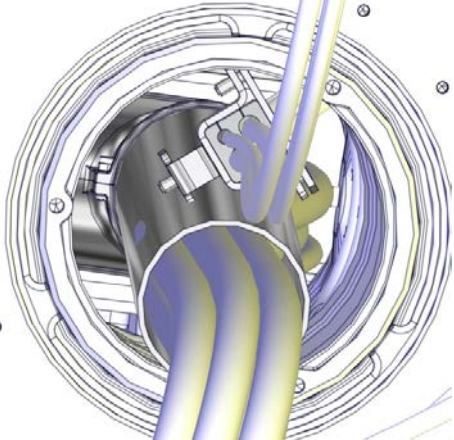
Continued

	Action	Note
6	<p>Run the cable harness through the cable guide and then into and through the upper arm tube.</p> <p> Tip</p> <p>This step is best performed by two persons working together:</p> <ul style="list-style-type: none">• Person 1: Put one hand inside the side hole of the arm tube and take a hold of the cable harness.• Person 2: Take a hold on the cable harness at the back of the robot.• Together: Use caution and move the cable harness into the arm tube. <p> Note</p> <p>The cable harness is best placed at the upper right hand side of the DressPack tube, if used, through the arm tube. Do not run the cable harness into the DressPack tube!</p> <p> Note</p> <p>Do not run the cable harness into the DressPack tube, if one is fitted!</p> <p> xx1300000820</p>	<p>Person 1, working at the side hole:</p> <p> xx1300000745</p> <p>Person 2, working at the back:</p> <p> xx1400000356</p>

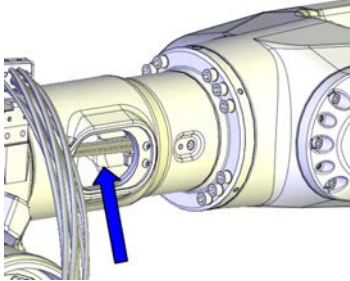
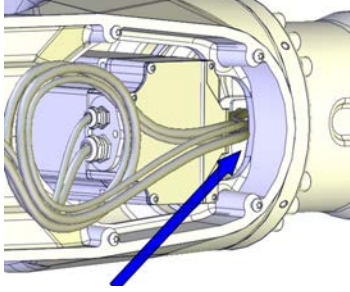
Continues on next page

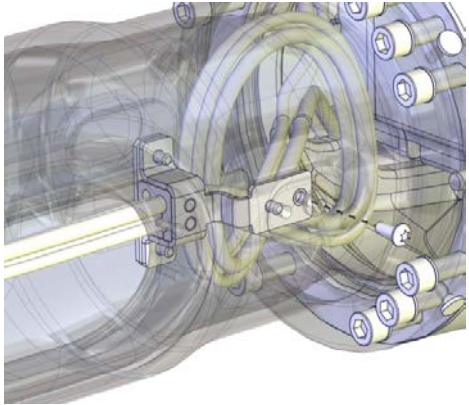
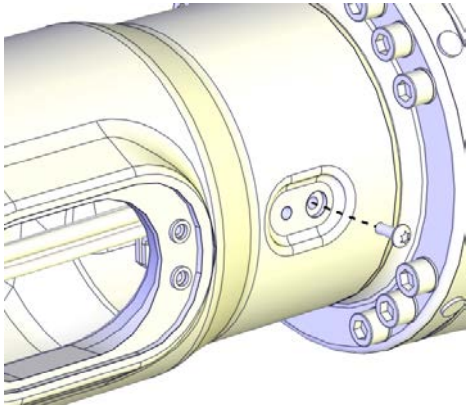
	Action	Note
7	<p>Use caution and push the cable harness into the wrist.</p> <p> Tip</p> <p>This step is best performed by two persons working together:</p> <ul style="list-style-type: none"> • Person 1: Put one hand inside the side cover hole and take a hold of the cable harness. • Person 2: Take a hold of the cable harness from inside the wrist. • Together: Move the cable harness past the axis-5 motor and into the wrist. 	<p>Person 1, working at the side hole:</p>  <p>xx130000745</p> <p>Person 2, working at the wrist:</p>  <p>xx130000746</p>
8	<p>Refit the metal clamp axis-4, inside the arm tube.</p> <p> Note</p> <p>The screws are reached from outside the upper arm.</p>	 <p>xx170000340</p>  <p>xx170000339</p>

Continues on next page

4 Repair

4.4.2 Refitting the cable harness

Continued

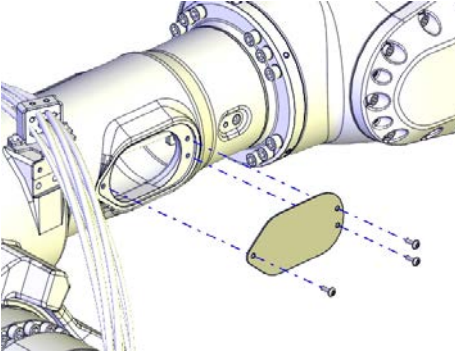
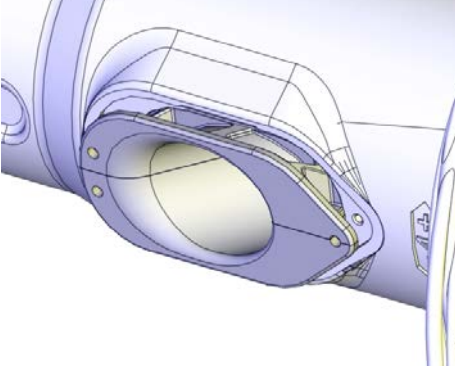
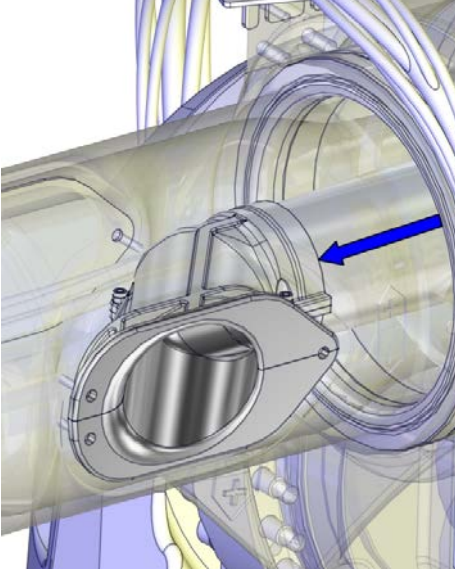
	Action	Note
9	<p>Refit the side cover.</p> <p> Note</p> <p><i>Foundry Plus:</i></p> <ul style="list-style-type: none">• Make sure the gasket is fitted correctly on the side cover• Use attachment screws made of stainless steel to fit the side cover.	 <p>xx130000557</p>
10	<p>If used, refit the insert that guides the DressPack cable package through the hole in the upper arm.</p>	 <p>xx170000690</p>
11	<p>If used, refit the tube containing the DressPack into the insert.</p>	 <p>xx140000092</p>

Continues on next page

Action	Note
<p>12 Fit the cover insert around the new cabling and secure it with a weatherstrip.</p>	<p>Cover insert: 3HAC048520-001.</p>  <p>xx1700001803</p> <p>Weatherstrip: 3HAC053986-001.</p>  <p>xx1700001804</p>
<p>13 <i>DressPack</i> or <i>Foundry Plus</i>: Refit the cover with the tube guiding ring fitted.</p> <p> Note</p> <p><i>Foundry Plus</i>:</p> <ul style="list-style-type: none"> • Make sure the gasket is fitted correctly • Use attachment screws made of stainless steel to fit the cover. 	 <p>xx1200000045</p>

Continues on next page



4 Repair

4.4.2 Refitting the cable harness

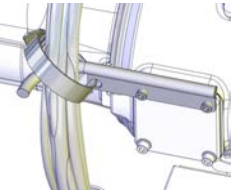
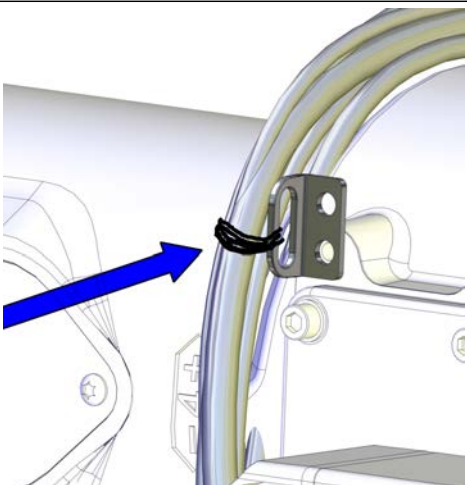

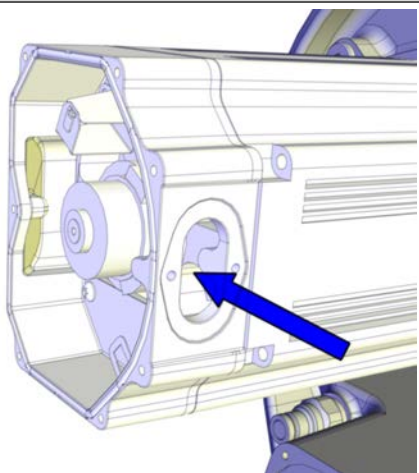

Continued

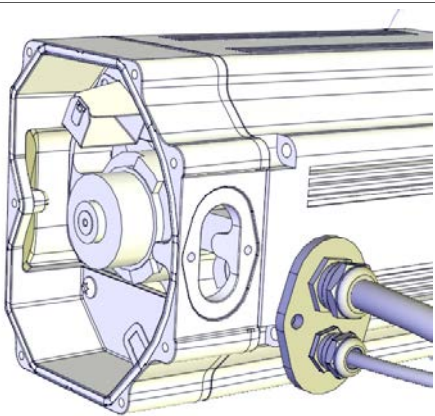
Action	Note
<p>14 Secure the cable harness to the cable fixing bracket with a cable tie.</p> <p> Note</p> <p>If DressPack is fitted, the cable fixing bracket is replaced by the cable guide.</p>  <p>xx1300001973</p>	 <p>xx130000544</p>

Connecting the axis-3 and axis-4 motor cables

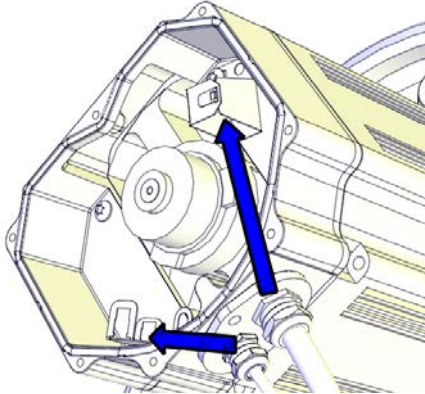
Action	Note
<p>1 Push the motor cables through the cable gland opening.</p>	 <p>xx130000738</p>
<p>2 Refit the cable gland cover.</p> <p> Note</p> <p>Replace the gasket if damaged.</p>	 <p>xx1200001067</p>

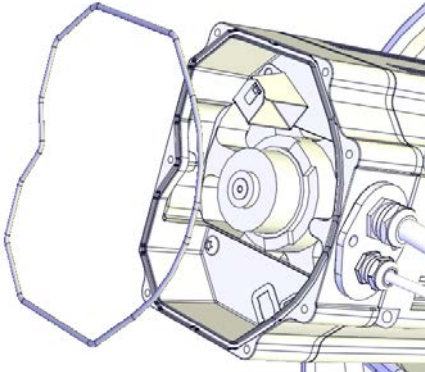
Continues on next page



	Action	Note
3	<p>Connect the motor cables. Connect in accordance with the markings on the connectors.</p>	 <p>xx1200001066</p>
4	<p>Inspect the o-ring.</p> <p> Note Replace if damaged.</p>	<p>O-ring, axis-1: 3HAB3772-111 (circular profile) / 3HAC054692-002 (hexagon profile) O-ring, axis-2: 3HAB3772-111 (circular profile) / 3HAC054692-002 (hexagon profile) O-ring, axis-3: 3HAB3772-111 (circular profile) / 3HAC054692-002 (hexagon profile) O-ring, axis-4: 3HAB3772-110 (circular profile) / 3HAC054692-001 (hexagon profile)</p>  <p>xx1200001070</p>
5	<p>Wipe clean o-ring and o-ring groove.</p>	
6	<p>Refit the o-ring.</p> <p> Tip Lubricate the o-ring with some grease for a better fitting in the groove.</p>	
7	<p> CAUTION When fitting the motor cover, make sure that none of the cables inside will be damaged.</p>	

Continues on next page



4 Repair

4.4.2 Refitting the cable harness

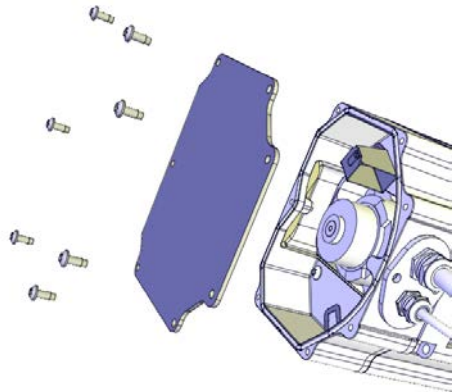

Continued

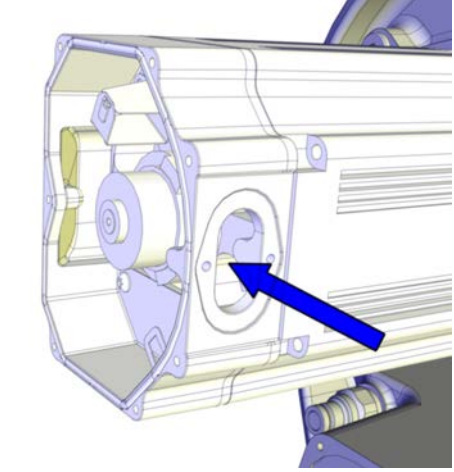
	Action	Note
8	<p>Refit the motor cover with its attachment screws.</p> <p> Note</p> <p>Do not reuse the self-threading attachment screws. Replace with standard attachment screws or the threads will be damaged.</p> <p> Note</p> <p>Make sure the o-ring is undamaged and properly fitted.</p>	<p>Attachment screws: M5x12 8.8 (7 pcs)</p>  <p>xx1200001135</p>
9	<p>Make sure that the covers are tightly sealed.</p>	

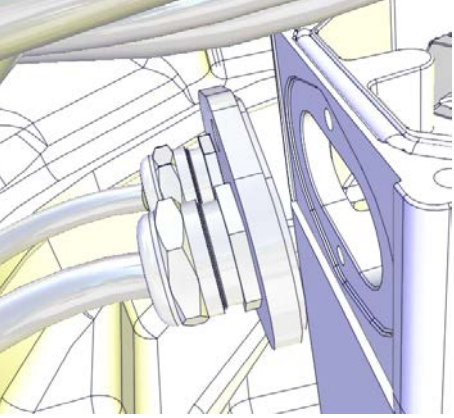
Connecting the axis-5 motor cables

	Action	Note
1	<p>Push the motor cables in through the cable gland opening.</p>	 <p>xx1300000738</p>
2	<p>Refit the cable gland cover by performing the following steps:</p> <ul style="list-style-type: none"> • Slide the cable gland cover onto the inner screw. • Refit and tighten the outer screw. • Tighten the inner screw. Make sure that the gasket is not damaged. <p> Note</p> <p>Replace the gasket if damaged.</p>	 <p>xx1200001016</p>

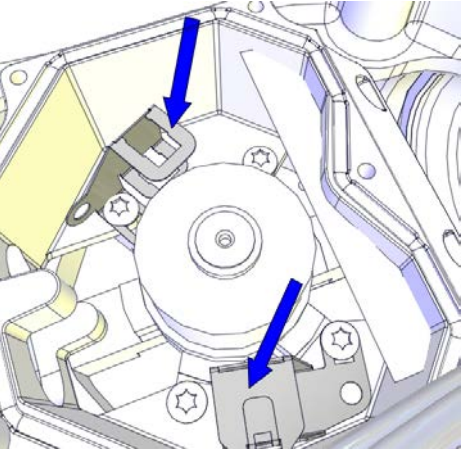
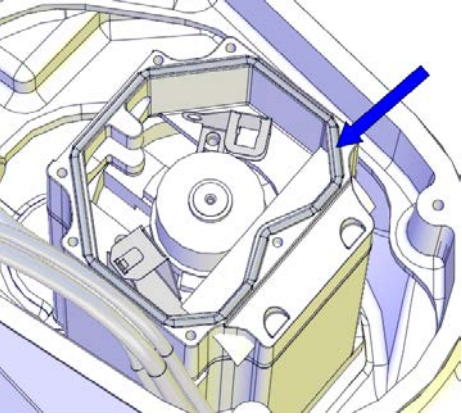
Continues on next page





	Action	Note
3	<p>Connect the connectors. Connect in accordance with the markings on the connectors.</p>	 <p>xx1200001015</p>
4	<p>Make sure the o-ring on the motor is undamaged. Replace if damaged.</p>	<p>O-ring, axis 5: 3HAB3772-110 (circular profile) / 3HAC054692-001 (hexagon profile).</p>  <p>xx1200001021</p>
5	<p> CAUTION</p> <p>When fitting the motor cover, make sure that none of the cables inside will be damaged.</p>	

Continues on next page

4 Repair

4.4.2 Refitting the cable harness

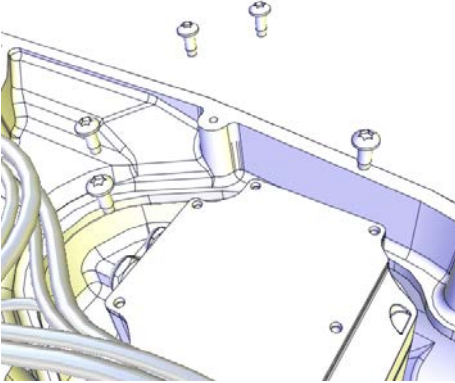
Continued

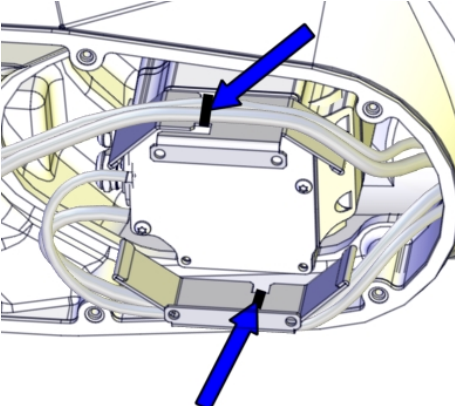
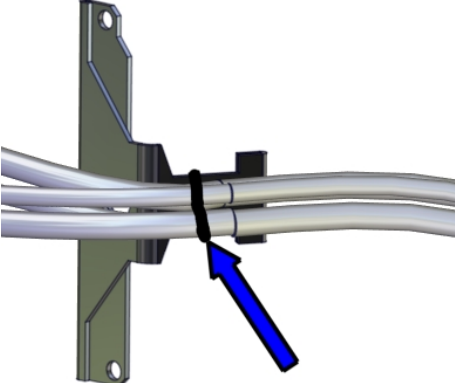
	Action	Note
6	<p>Refit the motor cover with its attachment screws.</p> <p> Note</p> <p>Do not refit the screws that will hold the heat protection plate at this point.</p> <p> Note</p> <p>Do not reuse the self-threading attachment screws, it will damage the threads. Replace with standard attachment screws.</p> <p> Note</p> <p>Make sure the o-ring is undamaged and properly fitted.</p>	<p>Screws: M5x12.</p>  <p>xx1200001013</p>
7	<p>Secure the cable harness with cable straps to the heat protection plate.</p> <p> Note</p> <p>If replacing a type A motor with a type B motor, the heat protection plate must be replaced with plates suited for the type B motor. See Type A vs type B motors on page 805.</p>	<p>There are two versions of the heat protection plates.</p> <p>Choose figure depending on which plate is installed on the robot.</p>  <p>xx1500001029</p>  <p>xx1300000489</p>

Continues on next page

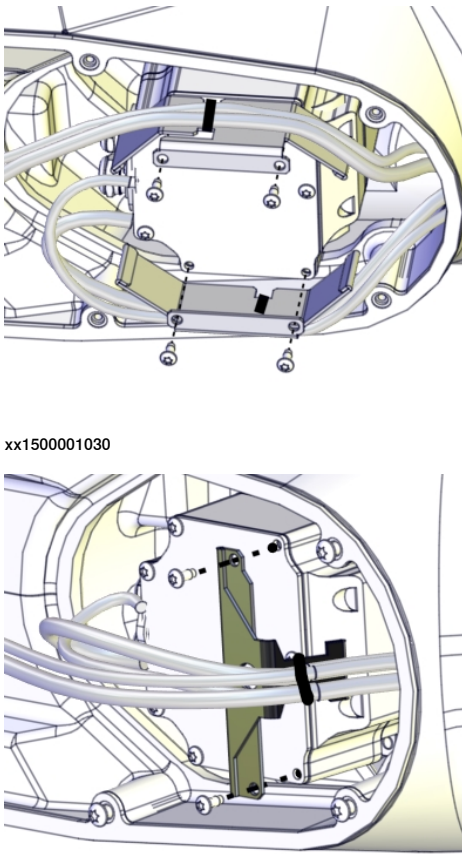

	Action	Note
8	Fit the heat protection plate with the screws.	<p>Choose figure depending on which plate is installed on the robot. Screws: M5x12.</p>  <p>xx1500001030</p> <p>xx1300000490</p>

4 Repair

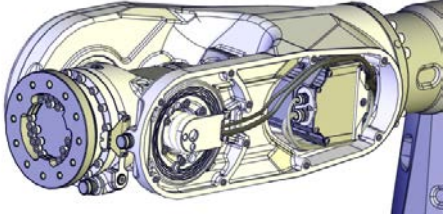
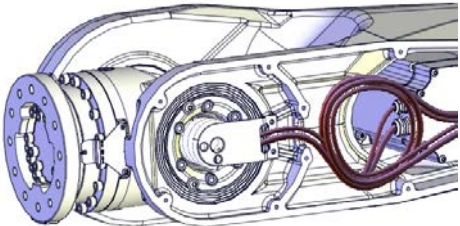

4.4.2 Refitting the cable harness

Continued

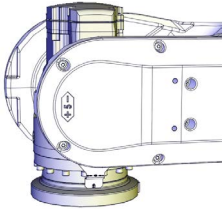
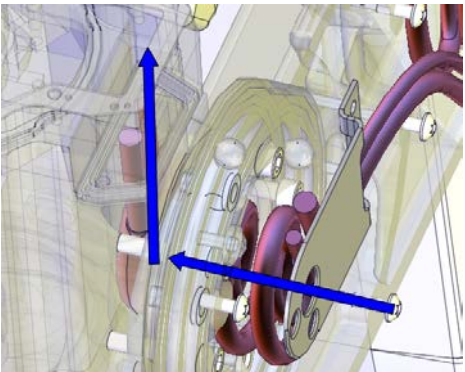
Connecting the axis-6 motor cables

	Action	Note
1	Make sure that the cable harness is placed in a way that it will not be damaged when the cover is fitted.	 <p>xx1600002061</p>  <p>xx1300000596</p> <p>Cable layout in the wrist with Type A motors.</p>
2	 Note Axis 5 must be in position +90° (or as close as possible) for a correct installation of the cable harness in the wrist. If not, connect the 24 VDC power supply, release the brakes and move axis 5 manually to +90°.	 <p>xx1200001081</p>
3	Push the cable harness into the wrist recess and up into the axis-6 motor.	 <p>xx1300000667</p>

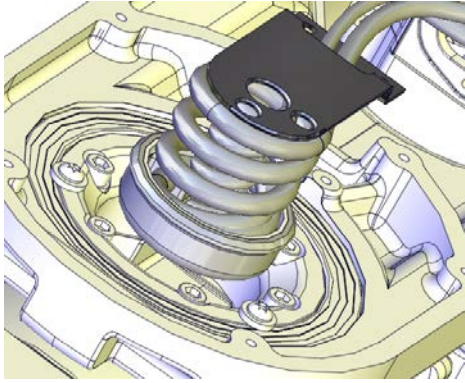
Continues on next page

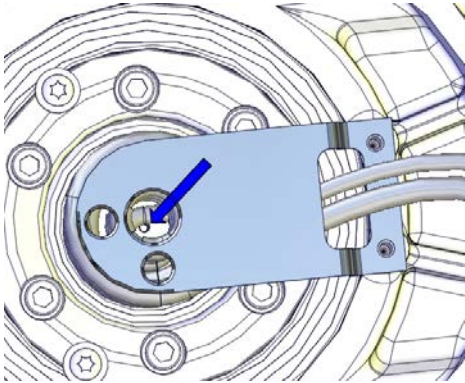
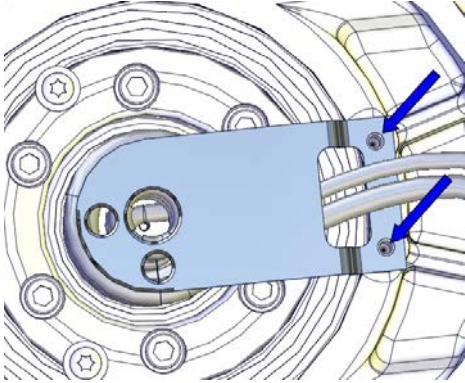

	Action	Note
4	<p>Push the carrier carefully into position.</p>	 <p>xx1300001113</p>
5	<p>Secure the carrier with the M4 screw.</p> <p> Note</p> <p>The screw is located at the bottom of the carrier.</p> <p> Tip</p> <p>The attachment screw securing the carrier may be difficult to fit. Make sure the carrier is level and completely pressed against the bottom.</p>	 <p>xx1300000485</p>
6	<p>Secure the cable bracket with its attachment screws.</p>	 <p>xx1300000484</p>

Continues on next page

4 Repair

4.4.2 Refitting the cable harness

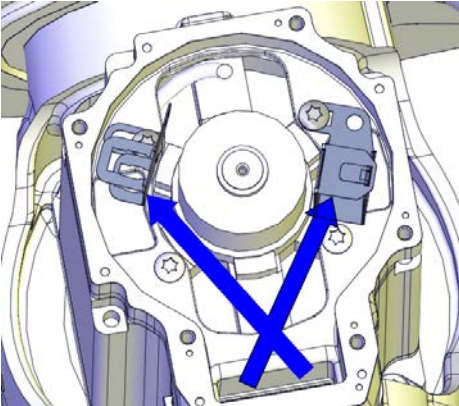
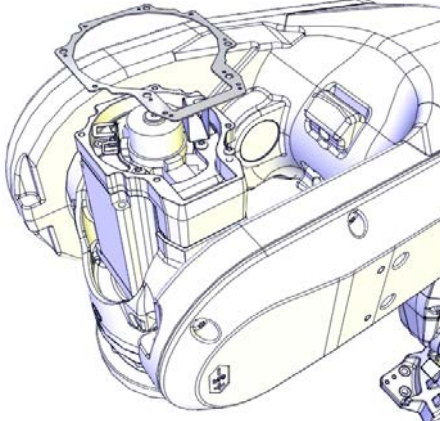
Continued

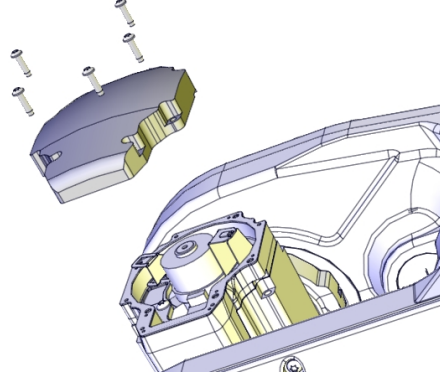
	Action	Note
7	<p>Reconnect the connectors to the axis-6 motor.</p> <p> Note</p> <p>Place the resolver cable under the motor cable.</p>	 <p>xx130000488</p>
8	<p>Make sure the gasket is undamaged. Replace if damaged.</p>	<p>Gasket, 3HAC033489-001/ 3HAC044252-001</p>  <p>xx1200001095</p>
9	<p> CAUTION</p> <p>When fitting the motor cover, make sure that none of the cables inside will be damaged.</p>	
10	<p>Refit the motor cover.</p>	 <p>xx1200001080</p>

Continues on next page

Concluding procedure

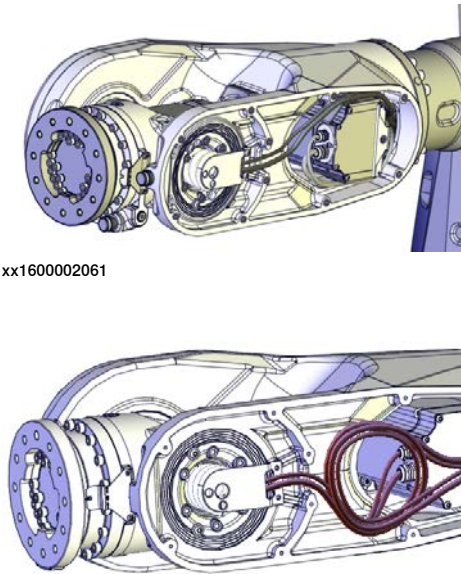
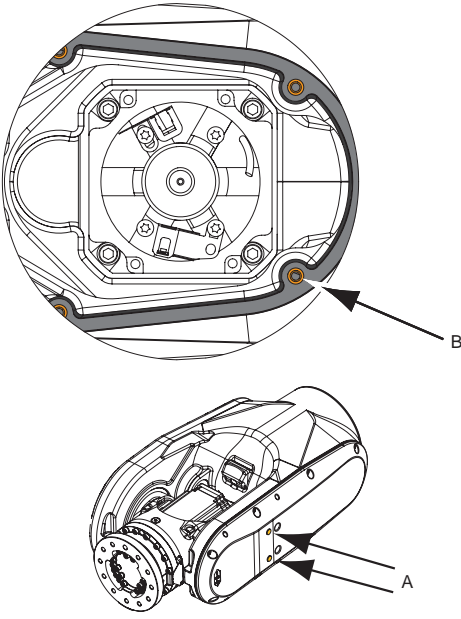

	Action	Note
1	<p>Make sure that the cable harness is placed in a way that it will not be damaged when the wrist cover is fitted.</p>	 <p>xx1600002061</p> <p>xx1300000596</p> <p>Cable layout in the wrist with Type A motors.</p>
2	<p><i>Foundry Plus:</i> Inspect the gasket. Replace if damaged. Put washers in the holes of the gasket.</p>	 <p>xx1400000383</p> <p>A Protection plugs (2 on wrist cover and 2 on cover axis-5 gearbox) B Washers (10 pcs) in gasket holes</p>

Continues on next page

4 Repair

4.4.2 Refitting the cable harness

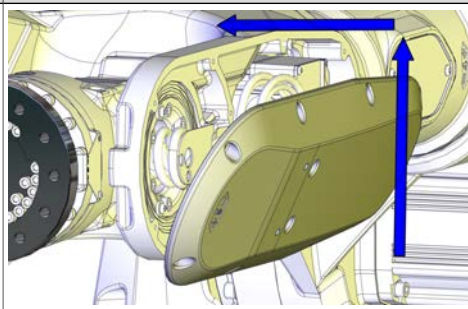
Continued

	Action	Note
3	<p>Refit the wrist cover. In order not to damage the cable harness when the wrist cover is refitted, use this method:</p> <ol style="list-style-type: none"> 1 Hold the cover slightly tilted below the wrist. 2 Put the cable harness inside the cover. 3 Lift the cover, still tilted. 4 Move the upper part of the cover into position. 5 Secure the cover with its attachment screws. 	 <p>xx1300000772</p> <p>Tightening torque: 10 Nm.</p>
4	<p><i>Foundry Plus:</i> Refit protection plugs.</p>	<p>See figure above!</p>
5	<p>If used, refit the DressPack cable package on the wrist.</p>	
6	<p>Re-calibrate the robot.</p>	<p>Pendulum Calibration is described in <i>Operating manual - Calibration Pendulum</i>, enclosed with the calibration tools.</p> <p>Axis Calibration is described in Calibrating with Axis Calibration method on page 781.</p> <p>General calibration information is included in section Calibration on page 767.</p>
7	<p> DANGER</p> <p>Make sure all safety requirements are met when performing the first test run.</p>	

4.4.3 Replacing the SMB

Location of SMB unit

The SMB (serial measurement board) unit is located inside the SMB/BU recess, as shown in the figure.

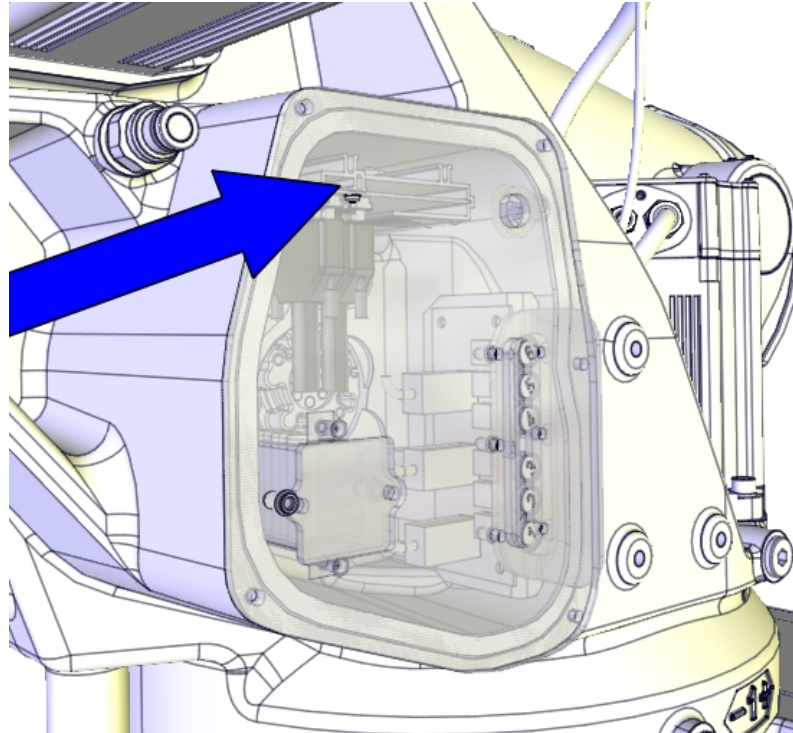

xx130000740

Spare part

Equipment, etc.	Article number	Note
SMB unit (DSQC633C)	See <i>Product manual, spare parts - IRB 6700/IRB 6700Inv.</i> <i>Product manual, spare parts - IRB 6790</i>	
Battery pack	See <i>Product manual, spare parts - IRB 6700/IRB 6700Inv.</i> <i>Product manual, spare parts - IRB 6790</i>	

Required tools and equipment

Equipment, etc.	Article number	Note
Standard toolkit	-	Content is defined in section Standard toolkit on page 814 .

Continues on next page

4 Repair





4.4.3 Replacing the SMB

Continued

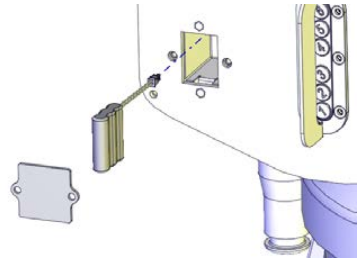

Removing the SMB unit

Use these procedures to disconnect and remove the SMB unit.

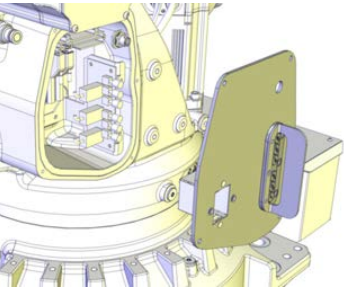
Preparations before disconnecting the SMB unit

	Action	Note
1	 DANGER Make sure that all supplies for electrical power, hydraulic pressure, and air pressure are turned off.	
2	 ELECTROSTATIC DISCHARGE (ESD) The unit is sensitive to ESD. Before handling the unit please read the safety information in the section The unit is sensitive to ESD on page 55	
3	Open the small cover on the SMB cover, disconnect the battery cable and remove the battery.	 xx1300000829
4	Remove the SMB cover.  CAUTION Clean cover from metal residues before opening. Metal residues can cause shortage on the boards which can result in hazardous failures.	 xx1300000669

Disconnecting and removing the SMB unit

	Action	Note
1	 DANGER Make sure that all supplies for electrical power, hydraulic pressure, and air pressure are turned off.	
2	 ELECTROSTATIC DISCHARGE (ESD) The unit is sensitive to ESD. Before handling the unit please read the safety information in the section The unit is sensitive to ESD on page 55	

Continues on next page

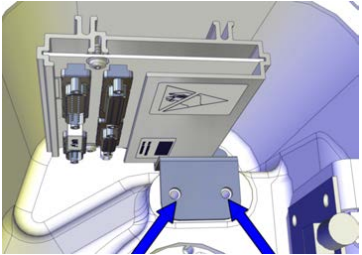
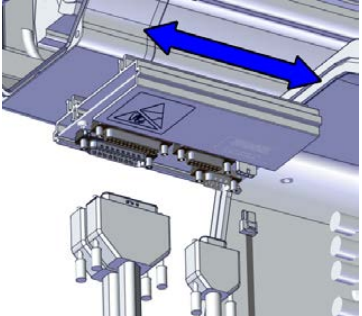
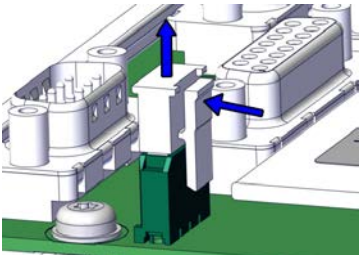
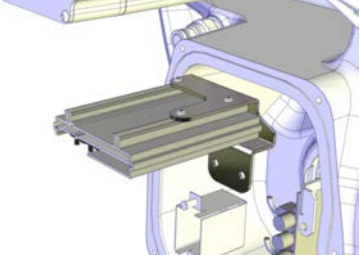
	Action	Note
3	Remove the screws and washers that secure the SMB unit bracket.	 <p>xx130000730</p>
4	Pull out the SMB unit a little and disconnect the connectors from the SMB board: <ul style="list-style-type: none"> • R1.SMB1-3, R1.SMB4-6 and R2.SMB • Battery cable connector R2.G. Disconnect the battery cable by pressing down the upper lip of the R2.G connector to release the lock while pulling the connector upwards.	 <p>xx130000728</p>  <p>xx1700000993</p>
5	Pull out the SMB unit and put it in an ESD bag.	 <p>xx130000731</p>

Refitting the SMB unit

Refitting the SMB unit

	Action	Note
1	 <p>DANGER</p> <p>Make sure that all supplies for electrical power, hydraulic pressure, and air pressure are turned off.</p>	

Continues on next page

4 Repair

4.4.3 Replacing the SMB

Continued

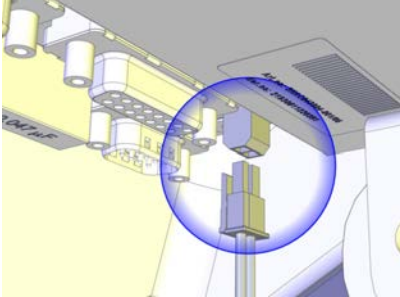
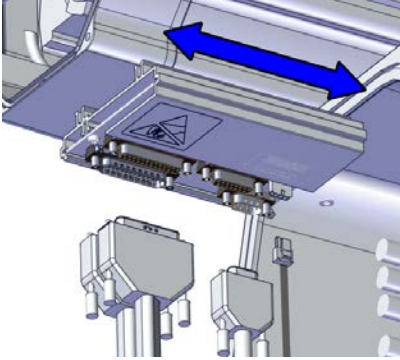
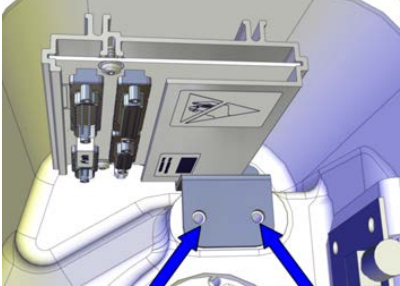
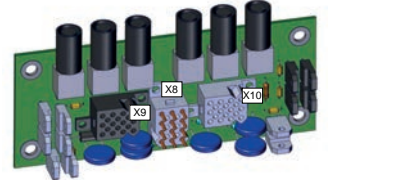
	Action	Note
2	 ELECTROSTATIC DISCHARGE (ESD) The unit is sensitive to ESD. Before handling the unit please read the safety information in the section The unit is sensitive to ESD on page 55	
3	Connect the battery cable to the SMB unit. Make sure the lock snaps into place during refitting.	 xx1300000729
4	Connect all connectors to the SMB board: <ul style="list-style-type: none"> • R1.SMB1-3, R1.SMB4-6 and R2.SMB 	 xx1300000728
5	Push the SMB unit carefully into position and fit the bracket that secures the SMB unit.	 xx1300000730
6	If disconnected, reconnect the connectors X8, X9 and X10 to the brake release board. Be careful not to damage the sockets or pins. Make sure the connector and its locking arms are snapped down properly.	 xx1700000978

Continues on next page

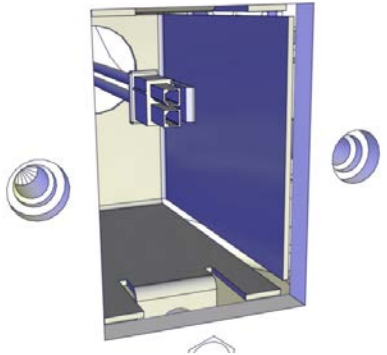
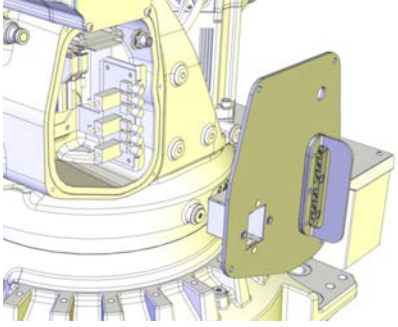
	Action	Note
7	Pull out the battery cable through the recess for the battery.	 <p data-bbox="1023 689 1134 707">xx130000834</p>
8	Secure the SMB cover with the attachment screws. If cabling is used for 7th axis (option), refit the connector R2.FB7 to the SMB cover and tighten with 6 Nm.	 <p data-bbox="1023 1070 1134 1088">xx130000669</p>

Refitting the SMB battery

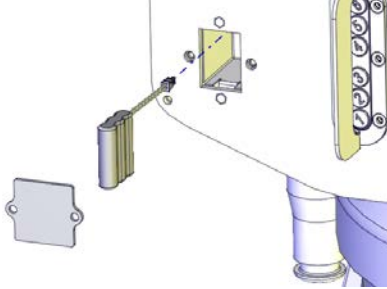
	Action	Note
1	 ELECTROSTATIC DISCHARGE (ESD) The unit is sensitive to ESD. Before handling the unit please read the safety information in the section The unit is sensitive to ESD on page 55	
2	Reconnect the battery cable.	
3	Place the battery in the recess.	 <p data-bbox="1023 1792 1134 1809">xx130000829</p>
4	Refit the battery cover with its attachment screws.	

Continues on next page

4 Repair

4.4.3 Replacing the SMB

Continued

Concluding procedures

	Action	Note
1	Update the revolution counters.	See Updating revolution counters on IRC5 robots on page 775 .
2	 DANGER Make sure all safety requirements are met when performing the first test run.	

4.4.4 Replacing the brake release unit

Location of brake release unit

The brake release unit (BU) is located inside SMB/BU recess, as shown in the figure.

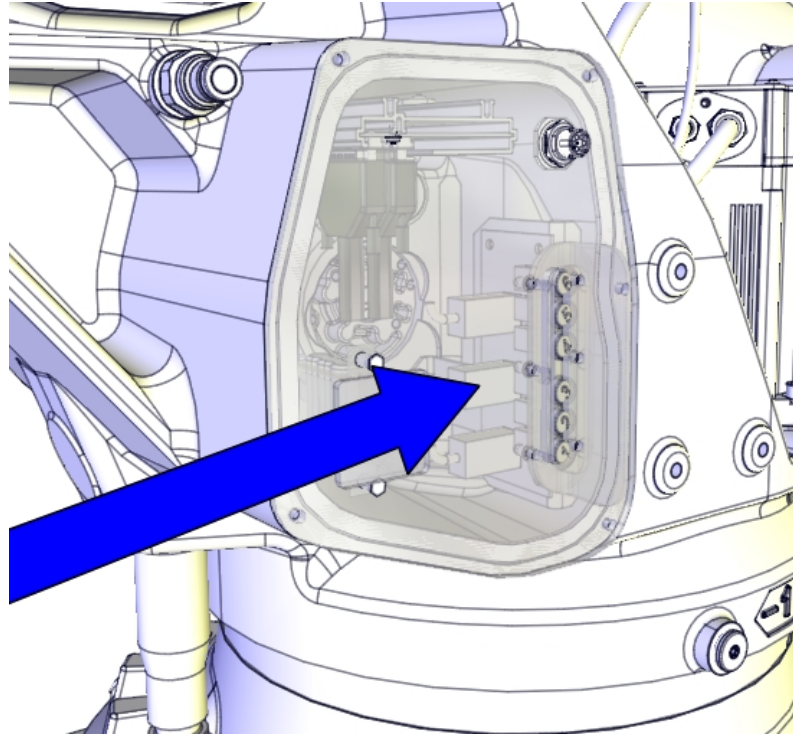

xx130000741

Spare part

Equipment, etc.	Article number	Note
Brake release unit	See <i>Product manual, spare parts - IRB 6700/IRB 6700Inv.</i> <i>Product manual, spare parts - IRB 6790</i>	
Battery pack	See <i>Product manual, spare parts - IRB 6700/IRB 6700Inv.</i> <i>Product manual, spare parts - IRB 6790</i>	

Required tools and equipment

Equipment, etc.	Article number	Note
Standard toolkit	-	Content is defined in section Standard toolkit on page 814 .

Continues on next page





4 Repair

4.4.4 Replacing the brake release unit

Continued

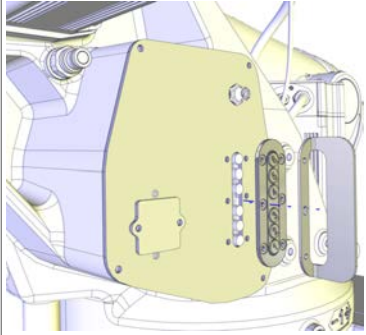
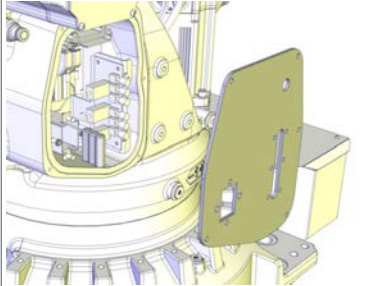

Removing the brake release unit

Preparations before removing the brake release unit

	Action	Note
1	 DANGER Turn off all: <ul style="list-style-type: none"> • electric power supply • hydraulic pressure supply • air pressure supply to the robot, before entering the safeguarded space.	
2	 ELECTROSTATIC DISCHARGE (ESD) The unit is sensitive to ESD. Before handling the unit please read the safety information in the section The unit is sensitive to ESD on page 55	
3	Remove the push button guard from the SMB cover. The push button guard must be removed to ensure a correct refitting of the brake release unit.	 xx130000743
4	Remove the SMB cover.	 xx130000742
5	The battery can stay connected, to avoid the need of synchronizing the robot.  CAUTION If the battery stays connected, put (or hold) the SMB cover in a safe position. The battery cable connectors can otherwise be damaged.	

Continues on next page

Disconnecting the brake release unit

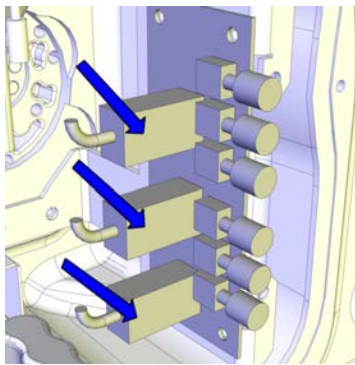
	Action	Note
1	 DANGER Make sure that all supplies for electrical power, hydraulic pressure, and air pressure are turned off.	
2	 ELECTROSTATIC DISCHARGE (ESD) The unit is sensitive to ESD. Before handling the unit please read the safety information in the section <i>The unit is sensitive to ESD on page 55</i>	
3	Take a picture or make notes of how the robot cabling is positioned in regard to the brake release board.	
4	Remove the connectors X8, X9 and X10 from the brake release board.	 xx130000670

Removing the brake release unit

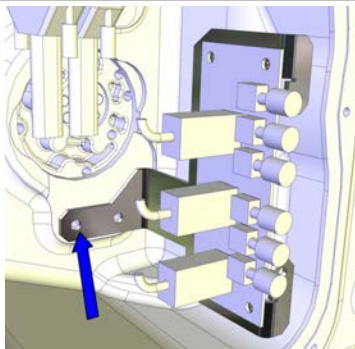
	Action	Note
1	Unscrew the attachment screws that secure the brake release unit bracket.	 xx130000744
2	Remove the bracket with the brake release unit fitted.	
3	Remove the brake release unit from the bracket.	

Continues on next page



4 Repair

4.4.4 Replacing the brake release unit

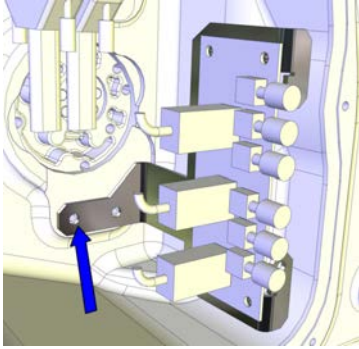
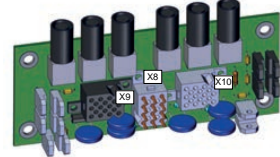

Continued

Refitting the brake release unit

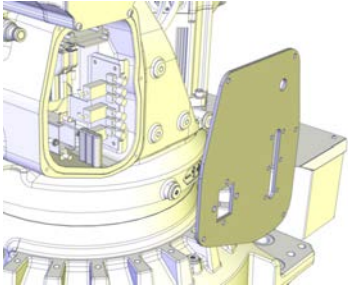
Use this procedure to refit the brake release unit.

	Action	Note
1	 ELECTROSTATIC DISCHARGE (ESD) The unit is sensitive to ESD. Before handling the unit please read the safety information in the section The unit is sensitive to ESD on page 55	
2	Fasten the brake release unit to the bracket.	Maximum tightening torque: 5 Nm.
3	Refit the bracket with the brake release unit fitted. Make sure the unit is placed as straight as possible on the bracket! The push buttons can otherwise get jammed when the SMB cover is refitted.	 xx1300000744
4	Reconnect the connectors X8, X9 and X10 to the brake release unit. Be careful not to damage the sockets or pins. Make sure the connector and its locking arms are snapped down properly.	 xx1700000978
5	Verify that the robot cabling is positioned correctly, according to previously taken picture/notes.  WARNING Screened cables must not get in contact with the brake release board after installation. Eliminate all risks of contact between screened cables and the brake release board.	
6	Refit the SMB cover with its attachment screws.  Note Do not refit the push button guard at this point!	 xx1300000742

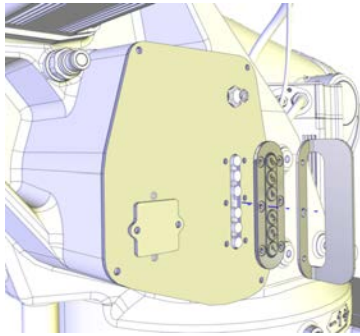
Continues on next page

	Action	Note
7	<p> WARNING</p> <p>Before continuing any service work, follow the safety procedure in section The brake release buttons may be jammed after service work on page 193!</p>	
8	<p>Refit the push button guard to the SMB cover.</p>	 <p>xx130000743</p>
9	<p>Press the push buttons 1 to 6, one at a time, to make sure that the buttons are moving freely and do not stay in any locked position.</p>	
10	<p>Reconnect the battery, if it has been disconnected.</p>	
11	<p>Update the revolution counters if the battery has been disconnected.</p>	<p>See Updating revolution counters on IRC5 robots on page 775.</p>
12	<p> DANGER</p> <p>Make sure all safety requirements are met when performing the first test run.</p>	

4 Repair

4.5.1 Replacing the upper arm

4.5 Upper and lower arms

4.5.1 Replacing the upper arm

Location of the upper arm

The upper arm is located as shown in the figure. These sections describe how to replace the complete upper arm, which includes the wrist unit.

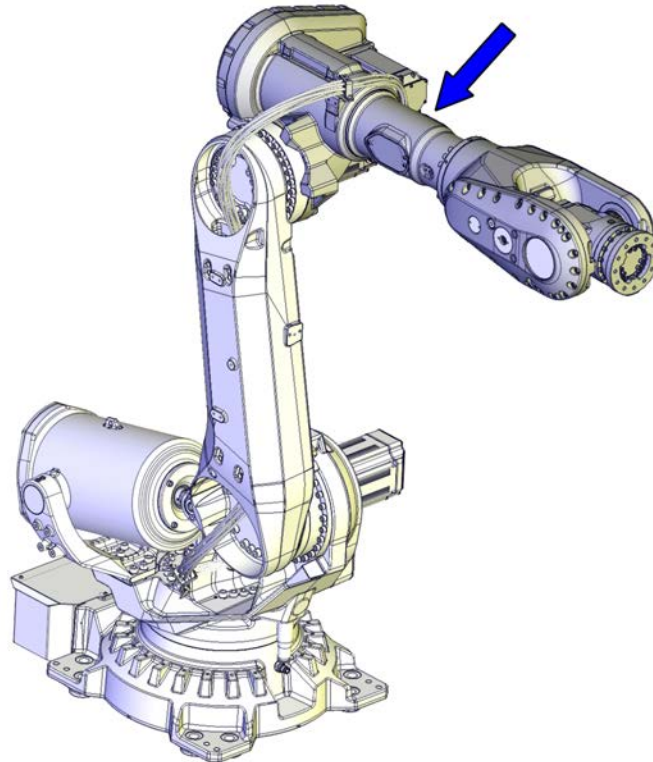

xx130000483

Spare part

Spare part	Spare part number	Note
Upper arm	See <i>Product manual, spare parts - IRB 6700/IRB 6700Inv.</i> <i>Product manual, spare parts - IRB 6790</i>	

Consumables

Parts needed to be replaced after removal.

Equipment, etc.	Article number	Note
Grease	3HAC042536-001	Shell Gadus S2 Used to lubricate o-rings.

Continues on next page

Equipment, etc.	Article number	Note
O-ring	3HAB3772-111 (circular profile) / 3HAC054692-002 (hexagon profile)	D=169.5x3 Used on axis-3 motor cover.
	3HAB3772-110 (circular profile) / 3HAC054692-001 (hexagon profile)	D=119x3 Used on axis-4 motor cover.
	3HAB3772-110 (circular profile) / 3HAC054692-001 (hexagon profile)	D=119x3 Used on axis-5 motor cover.
Gasket	3HAC033489-001/ 3HAC044252-001	Used on axis-6 motor cover.
Rust preventive	3HAC034903-001	Mercasol 3110 Waxcoat. Recommended drying time is 24h. Used on Foundry Plus.

Required tools and equipment

Equipment, etc.	Article number	Note
Lifting eye	3HAC16131-1	M12
Lifting eye	3HAC16131-1	M12
Fender washer	-	Outer diameter: minimum 26 mm, maximum 30 mm, hole diameter: 13 mm, thickness: 3 mm.
Lifting accessory (chain)	3HAC15556-1	Lifting instruction 3HAC15880-2 enclosed.
Pallet		Used for putting down removed parts from robot.
Guide pin, M12x150	3HAC13056-2	Always use guide pins in pairs.
Guide pin, M12x200	3HAC13056-3	Always use guide pins in pairs.
Guide pin, M16x150	3HAC13120-2	Always use guide pins in pairs.
Guide pin, M16x200	3HAC13120-3	Always use guide pins in pairs.
24 VDC power supply	-	Used to release the motor brakes.
Calibration Pendulum toolkit	3HAC15716-1	Required if Calibration Pendulum is the valid calibration method for the robot.
Calibration tool box, Axis Calibration	3HAC055412-001	Delivered as a set of calibration tools. Required if Axis Calibration is the valid calibration method for the robot.
Standard toolkit	-	Content is defined in section Standard toolkit on page 814 .

Continues on next page

4 Repair

4.5.1 Replacing the upper arm

Continued

Deciding calibration routine

Decide which calibration routine to be used, based on the information in the table. Depending on which routine is chosen, action might be required prior to beginning the repair work of the robot, see the table.

	Action	Note
1	Decide which calibration routine to use for calibrating the robot. <ul style="list-style-type: none">Reference calibration. External cable packages (DressPack) and tools can stay fitted on the robot.Fine calibration. All external cable packages (DressPack) and tools must be removed from the robot.	
	If the robot is to be calibrated with reference calibration: Find previous reference values for the axis or create new reference values. These values are to be used after the repair procedure is completed, for calibration of the robot. If no previous reference values exist, and no new reference values can be created, then reference calibration is not possible.	Follow the instructions given in the reference calibration routine on the FlexPendant to create reference values. Creating new values requires possibility to move the robot. Read more about reference calibration for Axis Calibration in Reference calibration routine on page 782 . Read more about reference calibration for Pendulum Calibration in <i>Operating manual - Calibration Pendulum</i> .
	If the robot is to be calibrated with fine calibration: Remove all external cable packages (DressPack) and tools from the robot.	

Removing the upper arm

Use these procedures to remove the upper arm.



Note

There is an alternative method to remove the upper arm if only the axis-3 gearbox shall be replaced. This alternative method describes how to remove the upper arm with the robot cable harness still partly fitted. See [Replacing the axis-3 gearbox on page 718](#).

Preparations before removing the upper arm

	Action	Note
1	Decide which calibration routine to use, and take actions accordingly prior to beginning the repair procedure.	
2	Jog the robot to a position where it is best to remove tools and other equipment fitted to wrist and upper arm.	

Continues on next page

	Action	Note
3	 DANGER Turn off all: <ul style="list-style-type: none"> • electric power supply • hydraulic pressure supply • air pressure supply to the robot, before entering the safe-guarded space.	
4	Remove tools and other equipment fitted to wrist and upper arm.	
5	Prepare an area where to put the upper arm, after removal. On pallets, as a suggestion.	

Position of the robot in the continued process

	Action	Note
1	Jog the robot into position: <ul style="list-style-type: none"> • Axis 1: No significance (as long as the robot is secured to the foundation) • Axis 2: -60° • Axis 3: +60° • Axis 4: +90° • Axis 5: +90° • Axis 6: No significance 	
2	 DANGER Turn off all: <ul style="list-style-type: none"> • electric power supply • hydraulic pressure supply • air pressure supply to the robot, before entering the safe-guarded space.	

Retrieving access to the wrist cabling

Use this procedure to remove the wrist cover to retrieve access to the axis-5 and axis-6 motor cables.

	Action	Note
1	 DANGER Make sure that all supplies for electrical power, hydraulic pressure, and air pressure are turned off.	

Continues on next page

4 Repair

4.5.1 Replacing the upper arm

Continued

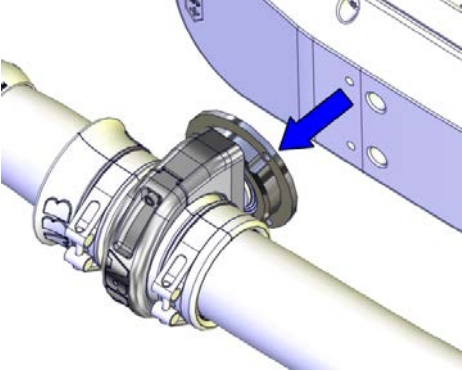
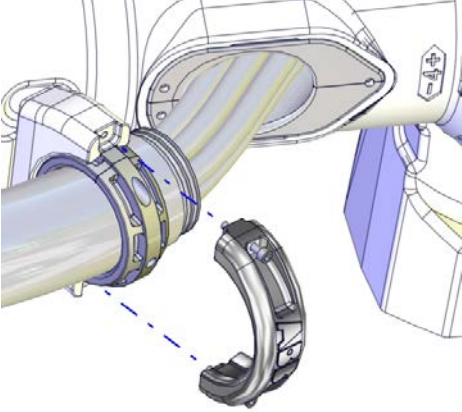
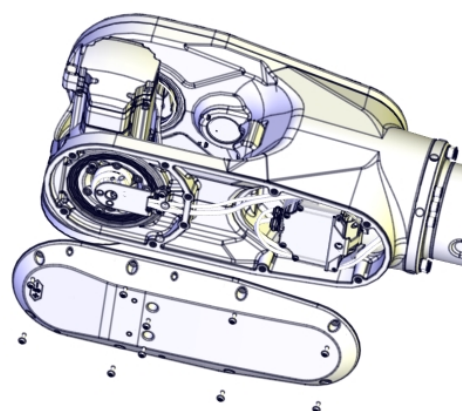
	Action	Note
2	<p>If DressPack is installed:</p> <ul style="list-style-type: none">Remove the bracket with the complete ball joint housing still fitted, as shown in the figure. <p>This is done to be able to reach the two hidden screws that secure the wrist cover.</p>	 <p>xx140000355</p>
3	<p>If used, open the ball joint housing on the arm tube and remove the DressPack cable package.</p>	 <p>xx140000206</p>
4	<p>Remove the wrist cover.</p>	 <p>xx1300002247</p>

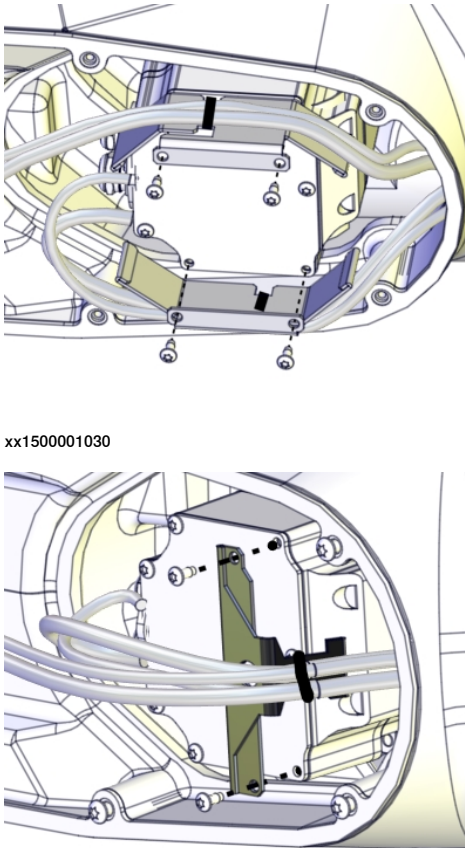

Continues on next page

	Action	Note
5	<p>Remove the heat protection plate/plates from the motor with the cabling still attached to the plate.</p> <p>Remove the heat protection plates from the motor with the cabling still attached to the plate.</p>	<p>There are two versions of the heat protection plates.</p> <p>Choose figure depending on which plate is installed on the robot.</p>  <p>xx1500001030</p> <p>xx1300000490</p>

4 Repair

4.5.1 Replacing the upper arm

Continued

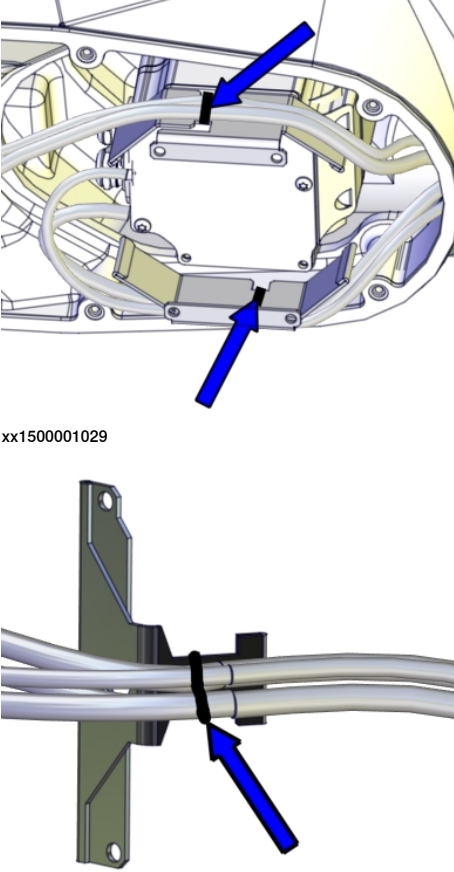
	Action	Note
6	<p>Cut the cable ties that hold the cable harness to the plate.</p> <p> Note</p> <p>Keep the heat protection plate until refitting.</p> <p> Tip</p> <p>If removing the plate only for replacing the motor, the cabling does not need to be loosened from the plate.</p>	<p>Choose figure depending on which plate is installed on the robot.</p>  <p>xx1500001029</p> <p>xx1300000489</p>

Removing the DressPack cable package

Remove the DressPack cable package from the upper arm, if used. How to remove the DressPack cable package is described in more detail in the product manual "IRB 6700 DressPack". For article number see [References on page 10](#).

Disconnecting the axis-5 motor cables

	Action	Note
1	<p> DANGER</p> <p>Make sure that all supplies for electrical power, hydraulic pressure, and air pressure are turned off.</p>	

Continues on next page

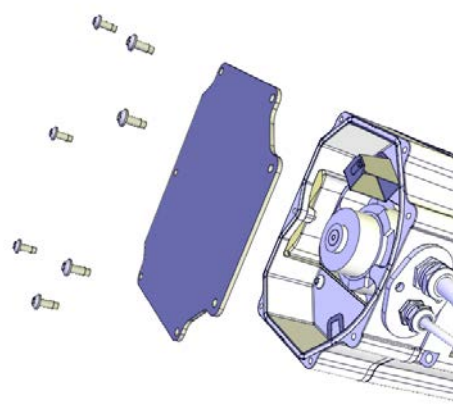
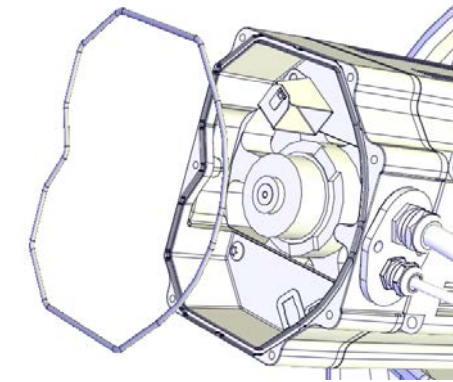
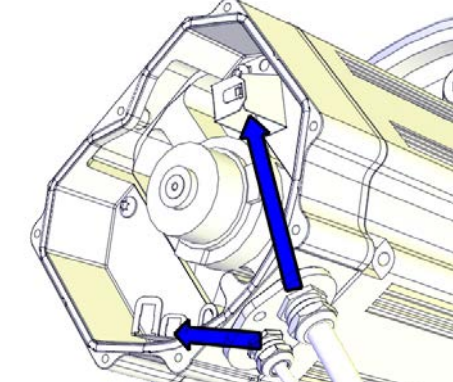
	Action	Note
2	Unscrew the attachment screws and washers and remove the motor cover.	 <p>xx1200001135</p>
3	Make sure the o-ring is present.	 <p>xx1200001070</p>
4	Disconnect the motor cables.	 <p>xx1200001066</p>

4 Repair

4.5.1 Replacing the upper arm

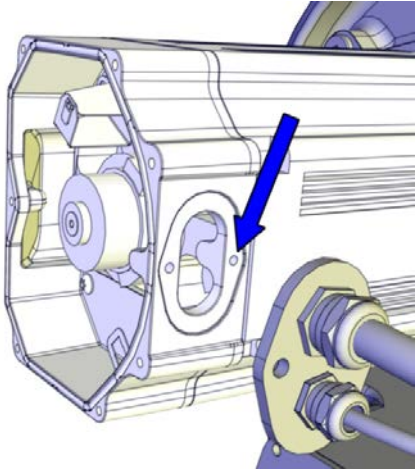

Continued

	Action	Note
5	<p>Remove the cable gland cover by performing the following steps:</p> <ol style="list-style-type: none"> 1 Open the inner screw a little (the one the arrow is pointing at). No need to remove this screw from the motor. 2 Remove the outer screw. 3 Slide the cable gland cover away from the inner screw. Make sure the gasket is not damaged. <p> Tip</p> <p>Make a note in which direction the cable exit hole is facing, if the motor will be removed too. The motor shall be refitted in the same position.</p>	 <p>xx1300000656</p>
6	Use caution and pull out the motor cables.	

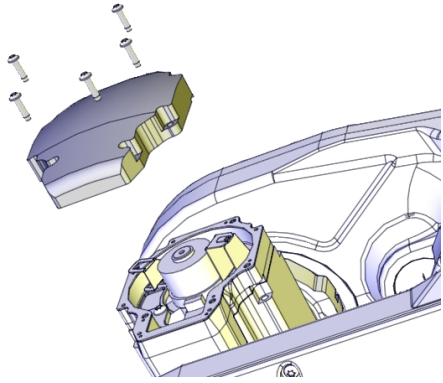
Disconnecting the axis-6 motor cables

	Action	Note
1	<p> DANGER</p> <p>Make sure that all supplies for electrical power, hydraulic pressure, and air pressure are turned off.</p>	
2	Unscrew the attachment screws and remove the motor cover.	 <p>xx1200001080</p>

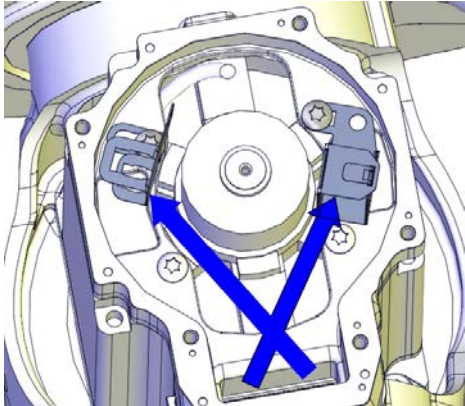
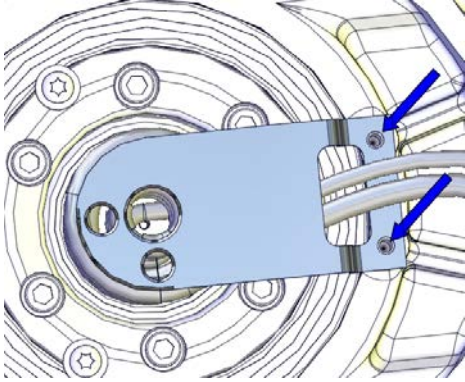
Continues on next page

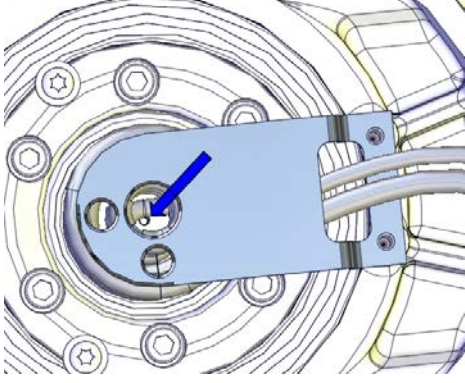
	Action	Note
3	Disconnect the motor cables.	 <p>xx130000488</p>
4	Unscrew the attachment screws that hold the cable bracket.	 <p>xx130000484</p>
5	Unscrew the M4 screw that holds the carrier.  Note The screw is located at the bottom of the carrier.	 <p>xx130000485</p>

Continues on next page

4 Repair

4.5.1 Replacing the upper arm

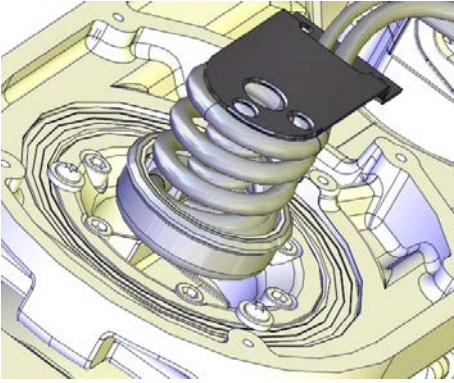
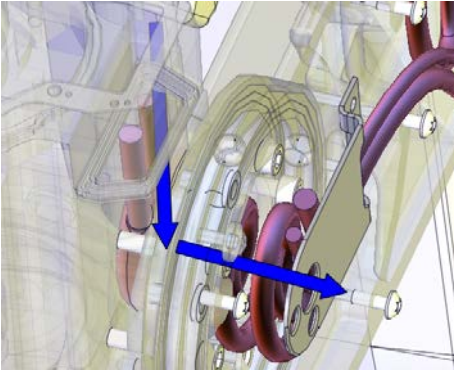

Continued

	Action	Note
6	Pull out the carrier from its position.	 <p>xx1300001113</p>
7	Pull out the axis-6 motor cables by holding the cables with one hand at the motor and the other at the carrier.	 <p>xx1300000666</p>

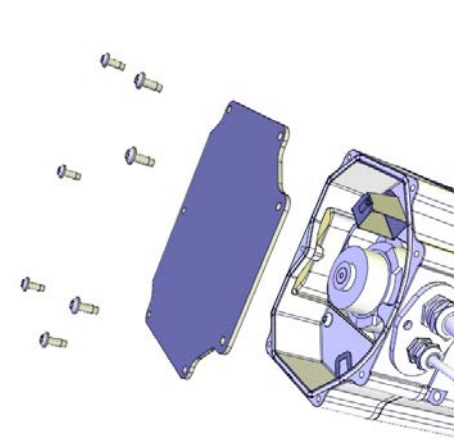
Disconnecting the axis-3 and axis-4 motor cables

	Action	Note
1	 DANGER Make sure that all supplies for electrical power, hydraulic pressure, and air pressure are turned off.	
2	Unscrew the attachment screws and washers and remove the motor cover.	 <p>xx1200001135</p>

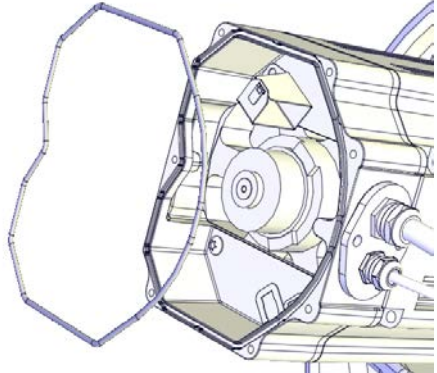
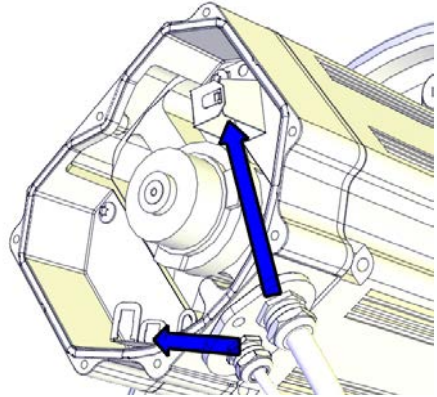
Continues on next page

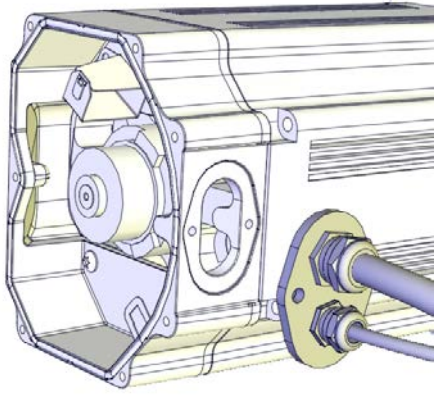
	Action	Note
3	Make sure the o-ring is present.	 <p>xx1200001070</p>
4	Disconnect the motor cables.	 <p>xx1200001066</p>
5	<p>Remove the cable gland cover. Make sure the gasket is not damaged.</p> <p> Tip</p> <p>Make a note in which direction the cable gland hole is facing, if the motor will be removed too. The motor shall be refitted in the same position.</p>	 <p>xx1200001067</p>
6	Use caution and pull out the motor cables.	

Continues on next page

4 Repair



4.5.1 Replacing the upper arm

Continued

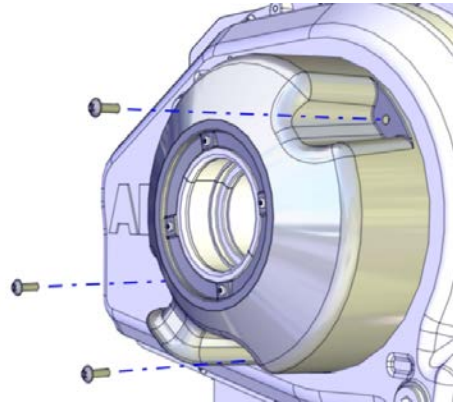
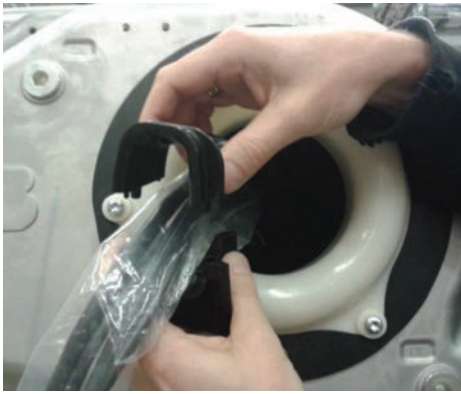
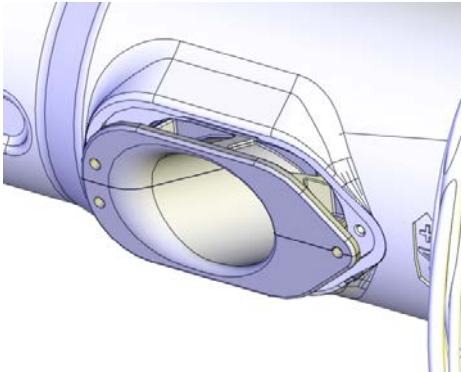
Removing the cable harness - wrist and upper arm

	Action	Note
1	<p>Remove the cover.</p> <p> Note</p> <p><i>Foundry Plus:</i> Use caution not to damage the gasket, not to loose the washers on the cover sealing or not to loose the inserts fitted on the cover.</p>	 <p>xx120000045</p>
2	<p>If the cabling is to be replaced by a new cable harness, remove the cover insert to use it on the new cabling.</p>	 <p>xx1700001803</p>
3	<p>If used, loosen the insert.</p>	 <p>xx1700000690</p>

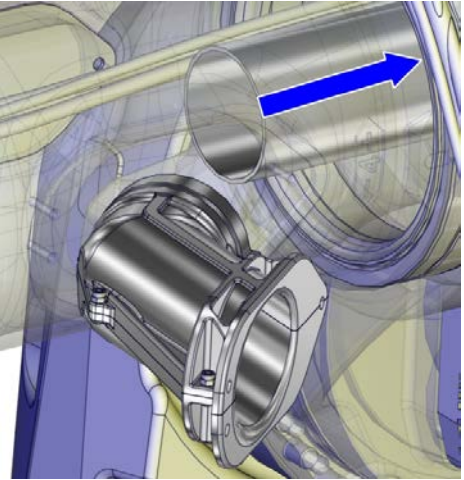
Continues on next page

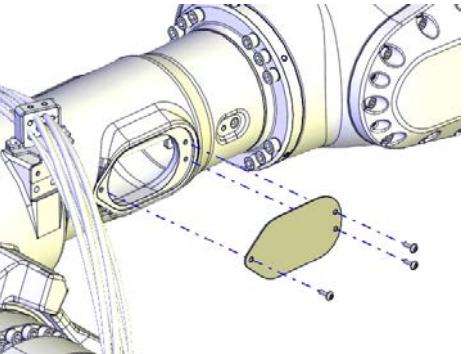
	Action	Note
4	If used, push the DressPack tube a little backwards.	 <p>xx140000720</p>
5	 Tip Use tape and tie the axis-5 and axis-6 connectors and carrier into a bundle (if not already done). This is done to facilitate the removal and to avoid damaging the parts. This will also make it easier to run the cable harness through the inside of the upper arm.	 <p>xx130000668</p>
6	Remove the side cover on the arm tube.	 <p>xx130000557</p>

Continues on next page

4 Repair

4.5.1 Replacing the upper arm

Continued

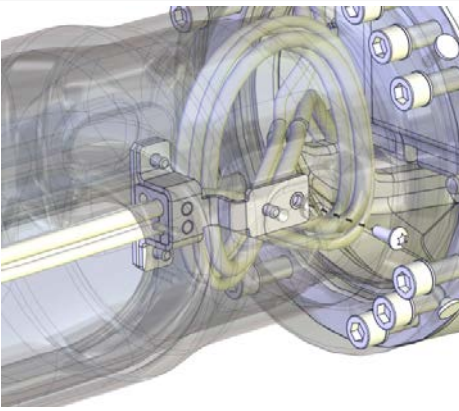
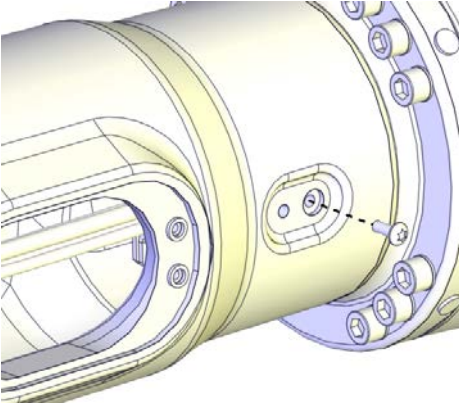
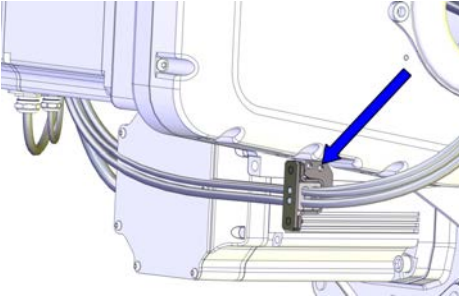
	Action	Note
7	<p>Unscrew the attachment screw that secures the axis-4 metal clamp inside the arm tube.</p> <p> Note</p> <p>The screw is reached from outside the upper arm.</p>	 <p>xx170000340</p>  <p>xx170000339</p>
8	Remove the arm house metal clamp.	 <p>xx130000543</p>

Continues on next page

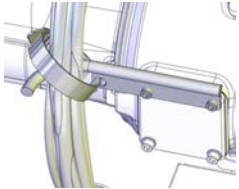
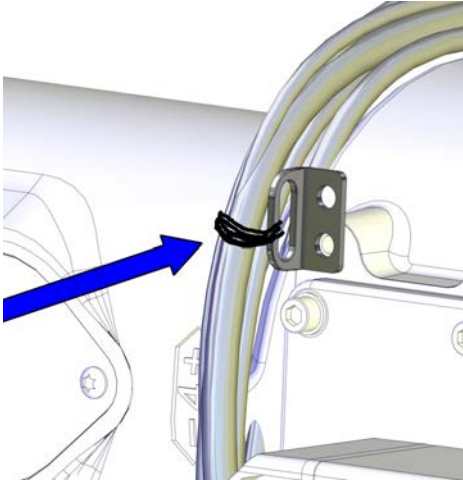
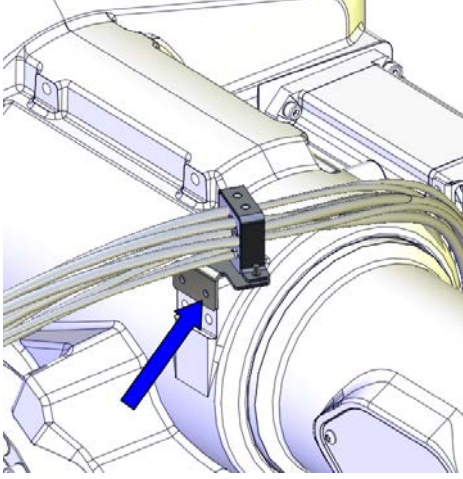

	Action	Note
9	<p>Cut the cable tie at the cable fixing bracket.</p> <p> Note</p> <p>If DressPack is fitted, the cable fixing bracket is replaced by the cable guide.</p>  <p>xx1300001973</p> <p>Cable guide.</p>	 <p>xx1300000544</p> <p>Cable fixing bracket.</p>
10	<p>Remove the metal clamp on top of the arm house.</p>	 <p>xx1300000541</p>

Continues on next page

4 Repair

4.5.1 Replacing the upper arm

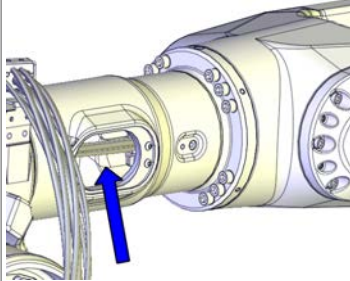
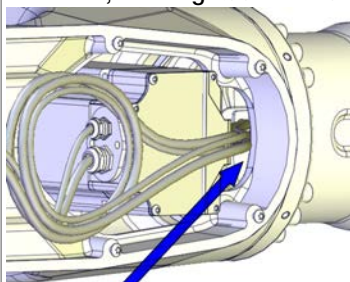

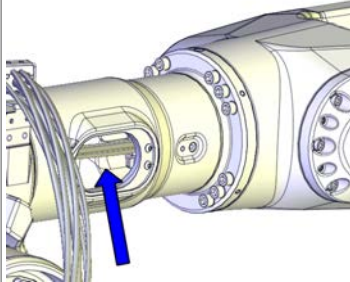
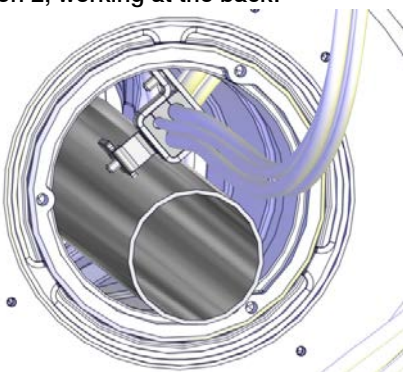
Continued

	Action	Note
11	<p>Remove the cable harness out from the wrist.</p> <p> Tip</p> <p>This step is best performed by two persons working together:</p> <ul style="list-style-type: none">• Person 1: Put one hand inside the side hole and take a hold of the cable harness.• Person 2: Take a hold on the cable harness inside the wrist.• Together: Move the cable harness past the axis-5 motor and into the arm tube.	<p>Person 1, working at the side hole:</p>  <p>xx130000745</p> <p>Person 2, working at the wrist:</p>  <p>xx130000746</p>
12	<p>Remove the cable harness out of the arm tube, at the back of the upper arm.</p> <p> Tip</p> <p>This step is best performed by two persons working together:</p> <ul style="list-style-type: none">• Person 1: Put one hand inside the side hole and take a hold of the cable harness.• Person 2: Take a hold on the cable harness at the back of the robot.• Together: Move the cable harness out of the arm tube. <p> Note</p> <p>To be able to remove the cable harness with the DressPack tube fitted, the tube needs to be pulled out a little, then be placed on the lower left side in the arm tube and the bracket of the cable harness then needs to be placed on the upper right hand side.</p> <p>(This is not needed on variants IRB 6700 - 300/2.70, -245/3.00)</p>	<p>Person 1, working at side hole:</p>  <p>xx130000745</p> <p>Person 2, working at the back:</p>  <p>xx1400002561</p>

Continues on next page

Attaching the lifting accessories

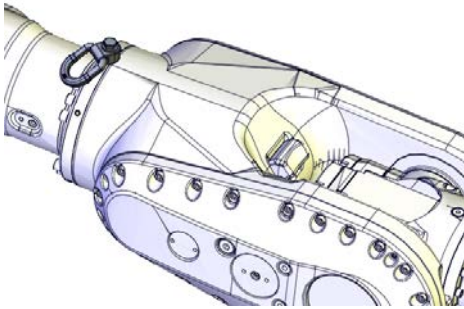
Use this procedure to attach the lifting accessories to the upper arm.

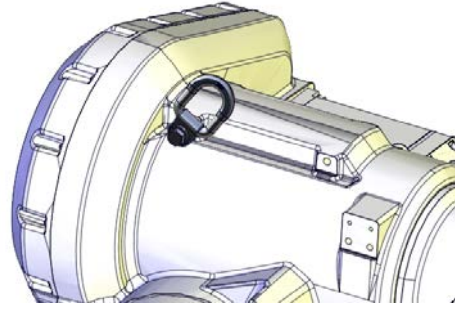
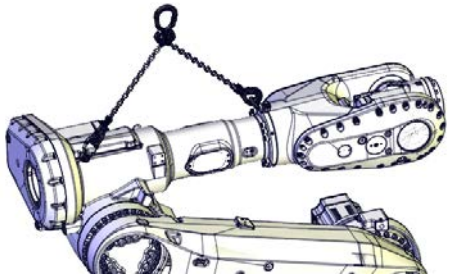
	Action	Note
1	<p> CAUTION</p> <p>The weight of the complete upper arm (including the wrist) is 360 kg (IRB 6700 -235/2.65, -205/2.80, -175/3.05, -150/3.20, -200/2.60, -155/2.85) 465 kg (IRB 6700 -300/2.70, -245/3.00) All lifting accessories used must be sized accordingly.</p>	
2	Fit a lifting eye to the wrist.	<p>Lifting eye: 3HAC16131-1</p>  <p>xx1200001133</p>
3	<p>Fit a lifting eye in the arm house, with a fender washer underneath.</p>  <p>xx1400002196</p>	<p>Lifting eye: 3HAC16131-1 Fender washer: Outer diameter: minimum 26 mm, maximum 30 mm, hole diameter: 13 mm, thickness: 3 mm.</p>  <p>xx1200001134</p>
4	Attach the upper arm lifting accessory (chain) to an overhead crane (or similar) and then to the lifting eye in the arm house and in the wrist.	<p>Lifting accessory (chain): 3HAC15556-1</p>  <p>xx1200001308</p>

Continues on next page



4 Repair

4.5.1 Replacing the upper arm

Continued

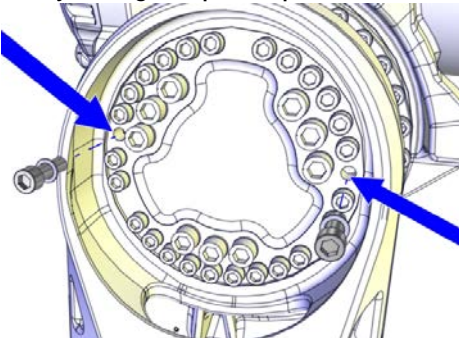
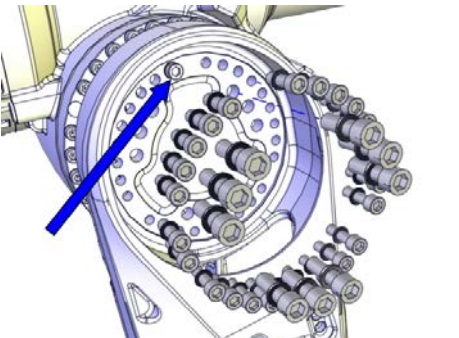

	Action	Note
5	Raise the lifting accessories to take the weight of the upper arm.	
6	In case of necessary adjustments, use the shortening loops on the lifting accessory (chain) to find the level position.	 <p data-bbox="943 730 1050 748">xx1400002197</p>

Preparations before removing the upper arm - IRB 6700 - 235/2.65, IRB 6700 - 205/2.80, IRB 6700 - 175/3.05, IRB 6700 - 150/3.20



	Action	Note
1	<p data-bbox="464 922 935 1016">Remove two attachment screws (M12) in opposite holes and replace them with guide pins.</p> <p data-bbox="464 1032 528 1093"> Note</p> <p data-bbox="464 1106 935 1189">Make sure that it is the screws that hold the lower arm to the axis-3 gearbox that are removed!</p> <p data-bbox="464 1205 528 1265"> Tip</p> <p data-bbox="464 1279 935 1346">Lubricate the guide pins with some grease to make the upper arm slide better.</p>	<p data-bbox="940 922 1404 1032">Guide pin, M12x150: 3HAC13056-2 Guide pin, M12x200: 3HAC13056-3 Always use guide pins in pairs.</p>  <p data-bbox="943 1379 1050 1397">xx130000659</p>
2	<p data-bbox="464 1426 935 1494">Leave one of the remaining attachment screws fitted, remove the other screws.</p>	 <p data-bbox="943 1774 1050 1792">xx130000747</p>

Continues on next page

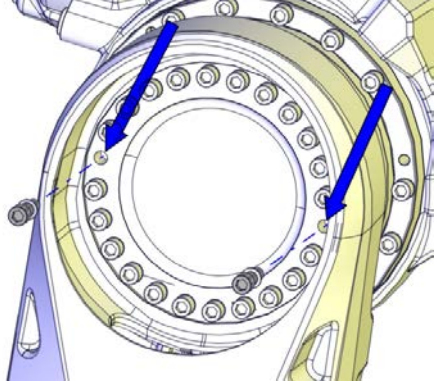
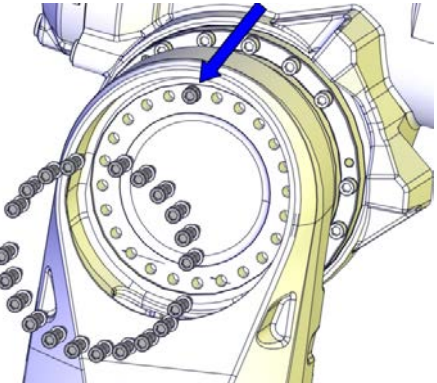
Preparations before removing the upper arm - IRB 6700 - 200/2.60, IRB 6700 - 155/2.85

	Action	Note
1	<p>Remove two attachment screws in opposite holes and replace them with guide pins.</p> <p> Note</p> <p>Make sure that it is the screws that hold the lower arm to the axis-3 gearbox that are removed!</p> <p> Tip</p> <p>Lubricate the guide pins with some grease to make the upper arm slide better.</p>	<p>Guide pin, M12x150: 3HAC13056-2 Guide pin, M12x200: 3HAC13056-3 Always use guide pins in pairs.</p>  <p>xx1300002245</p>
2	<p>Leave one of the remaining attachment screws fitted, remove the other screws.</p>	 <p>xx1300002246</p>

Preparations before removing the upper arm - IRB 6700 - 300/2.70, IRB 6700 - 245/3.00

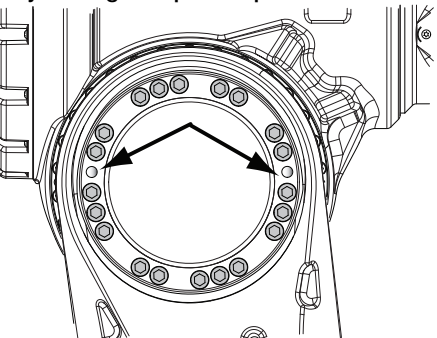
	Action	Note
1	<p>Remove two attachment screws in opposite holes and replace them with guide pins.</p> <p> Note</p> <p>Make sure that it is the screws that hold the lower arm to the axis-3 gearbox that are removed!</p> <p> Tip</p> <p>Lubricate the guide pins with some grease to make the upper arm slide better.</p>	<p>Guide pin, M16x150: 3HAC13120-2 Guide pin, M16x200: 3HAC13120-3 Always use guide pins in pairs.</p>  <p>xx1400002563</p>

Continues on next page



4 Repair

4.5.1 Replacing the upper arm

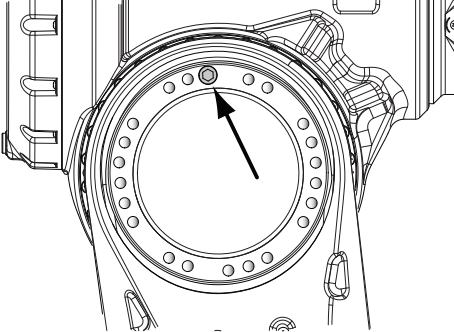

Continued

	Action	Note
2	Leave one of the remaining attachment screws fitted, remove the other screws.	 <p>xx1400002564</p>

Removing the upper arm

	Action	Note
1	 Note Make sure the lift is done completely leveled! In case of necessary adjustments, use the shortening loops on the lifting accessory (chain), and make sure to place the chain the right way through the loops.	 <p>xx1400002197</p>

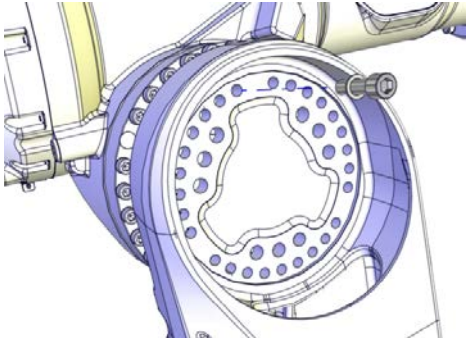
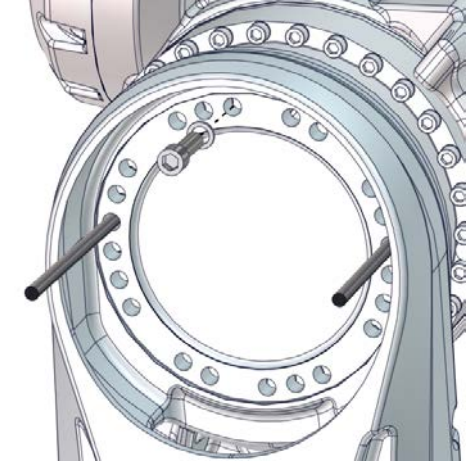
Continues on next page

	Action	Note
2	<p>Remove the remaining attachment screw and let the upper arm slide out from the lower arm with support from the guide pins.</p>	<p>IRB 6700 - 235/2.65, IRB 6700 - 205/2.80, IRB 6700 - 175/3.05, IRB 6700 - 150/3.20</p>  <p>xx1300001610</p> <p>IRB 6700 - 200/2.60, IRB 6700 - 155/2.85 TBD IRB 6700 - 300/2.70, IRB 6700 - 245/3.00</p>  <p>xx1700000059</p>
3	<p>Lift the upper arm and place it on the prepared area.</p> <p> CAUTION</p> <p><i>Only valid when the upper arm is removed due to replacement of the axis-3 gearbox:</i> If the cable harness is still fitted or partly fitted, use caution when lifting the upper arm over to the other side of the robot, in order not to cause any damage to the cable harness.</p>	

4 Repair

4.5.1 Replacing the upper arm

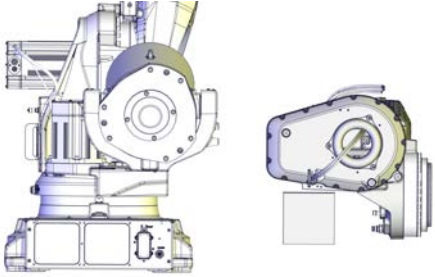

Continued

	Action	Note
4	<p><i>This step is only valid when the upper arm is removed due to replacement of the axis-3 gearbox:</i></p> <p>Place pieces of wood (or similar) under arm house and wrist. Lower the upper arm, and let the upper arm rest as shown in the figure.</p> <p>This is done in order to keep the axis-3 gearbox in a vertical position and to get the best position to replace the axis-3 gearbox, if applicable.</p>	 <p>xx1300000553</p>

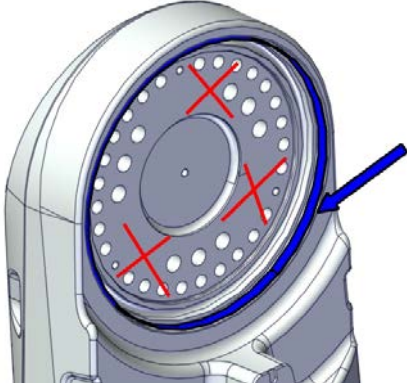

Refitting the upper arm

Use these procedures to refit the upper arm.

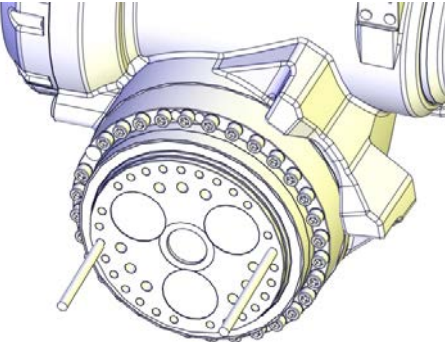
Preparations before refitting the upper arm

	Action	Note
1	Wipe clean all contact surfaces.	
2	<p><i>Foundry Plus:</i></p> <p>Apply Mercasol on the surface on the lower arm as shown in the figure.</p> <p> CAUTION</p> <p>Keep the sealing surfaces clean from Mercasol.</p>	<p>Rust preventive: 3HAC034903-001 (Mercasol 3110 Waxcoat. Recommended drying time is 24h.)</p>  <p>xx1700001880</p>
3	<p>IRB 6700 - 235/2.65, IRB 6700 - 205/2.80, IRB 6700 - 175/3.05, IRB 6700 - 150/3.20</p> <p>Fit two guide pins in opposite M12 holes in the axis-3 gearbox.</p> <p> Tip</p> <p>Lubricate the guide pins with some grease to make the upper arm slide better.</p>	<p>Guide pin, M12x150: 3HAC13056-2 Guide pin, M12x200: 3HAC13056-3</p> <p>Always use guide pins in pairs.</p>  <p>xx1700000058</p>

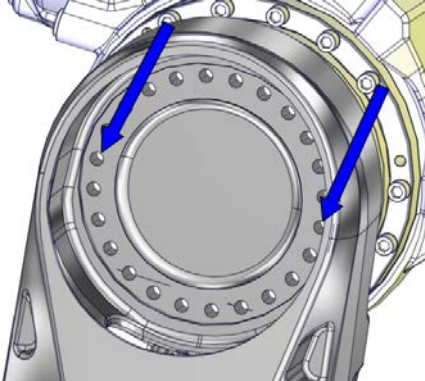
Continues on next page

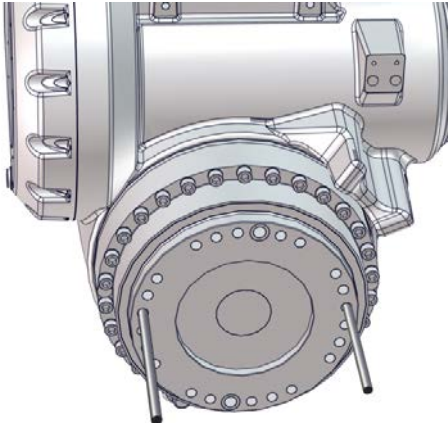
	Action	Note
4	<p>IRB 6700 - 200/2.60, IRB 6700 - 155/2.85 Fit two guide pins in opposite M12 holes in the axis-3 gearbox.</p> <p> Tip</p> <p>Lubricate the guide pins with some grease to make the upper arm slide better.</p>	<p>Guide pin, M12x150: 3HAC13056-2 Guide pin, M12x200: 3HAC13056-3 Always use guide pins in pairs.</p>  <p>xx1400000361</p>
5	<p>IRB 6700 - 300/2.70, IRB 6700 - 245/3.00 Fit two guide pins in opposite M16 holes in the axis-3 gearbox.</p> <p> Tip</p> <p>Lubricate the guide pins with some grease to make the upper arm slide better.</p>	<p>Guide pin, M16x150: 3HAC13120-2 Guide pin, M16x200: 3HAC13120-3 Always use guide pins in pairs.</p>  <p>xx1700000056</p>

Securing the upper arm - IRB 6700 - 235/2.65, IRB 6700 - 205/2.80, IRB 6700 - 175/3.05, IRB 6700 - 150/3.20

	Action	Note
1	<p> CAUTION</p> <p>The weight of the complete upper arm (including the wrist) is 360 kg (IRB 6700 -235/2.65, -205/2.80, -175/3.05, -150/3.20, -200/2.60, -155/2.85) 465 kg (IRB 6700 -300/2.70, -245/3.00) All lifting accessories used must be sized accordingly.</p>	
2	<p>Attach the lifting accessories, if not already fitted.</p>	<p>See Attaching lifting accessories to the upper arm on page 216.</p>

Continues on next page

4 Repair

4.5.1 Replacing the upper arm

Continued

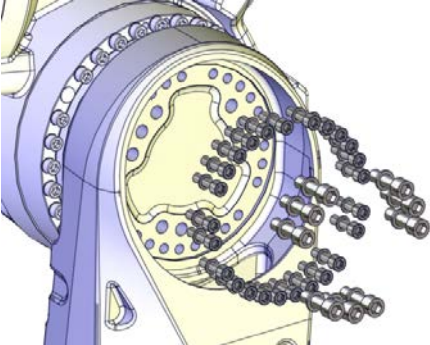
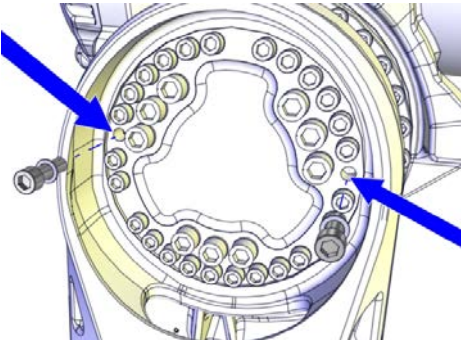
	Action	Note
3	Lift the upper arm and put it on the guide pins.	
4	If the axis-3 motor is installed to the upper arm: In order to release the brakes, connect the 24 VDC power supply. Connect to R2.MP3-connector: <ul style="list-style-type: none"> • + = pin 2 • - = pin 5 Use the rotation tool and rotate the axis-3 motor to find the correct position for the guide pins in the lower arm.	24 VDC power supply Rotation tool
5	If the axis-3 motor is not installed to the upper arm: Use the pinion to rotate the axis-3 gearbox to find the correct position for the guide pins in the lower arm.	Pinion: 3HAC067546-001 ⁱ 3HAC067547-001 ⁱⁱ 3HAC067545-001 ⁱⁱⁱ
6	Insert all nine M16 screws and 25 of the 27 M12 screws.	Screws: M16 (9 pcs) M12 (25 of 27 pcs)  xx1400000359
7	Remove the guide pins and fit the two remaining M12 screws.	 xx1300000659
8	Secure the upper arm by tightening the attachment screws.	Tightening torque depends on screw dimension. Tightening torque, M16: 300 Nm Tightening torque, M12: 120 Nm

ⁱ IRB 6700 - 235/2.65, IRB 6700 - 205/2.80, IRB 6700 - 175/3.05, IRB 6700 - 150/3.20

ⁱⁱ IRB 6700 - 200/2.60, IRB 6700 - 155/2.85

ⁱⁱⁱ IRB 6700 - 300/2.70, IRB 6700 - 245/3.00

Continues on next page

Securing the upper arm - IRB 6700 - 200/2.60, IRB 6700 - 155/2.85

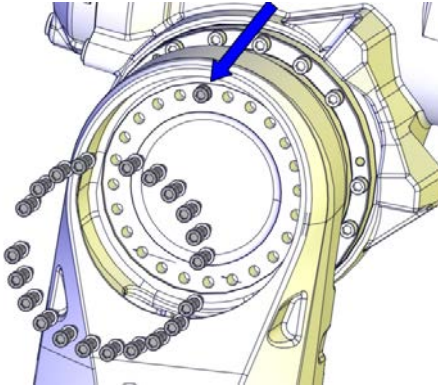
	Action	Note
1	<p> CAUTION</p> <p>The weight of the complete upper arm (including the wrist) is 360 kg (IRB 6700 -235/2.65, -205/2.80, -175/3.05, -150/3.20, -200/2.60, -155/2.85) 465 kg (IRB 6700 -300/2.70, -245/3.00) All lifting accessories used must be sized accordingly.</p>	
2	Attach the lifting accessories, if not already fitted.	See Attaching lifting accessories to the upper arm on page 216 .
3	Lift the upper arm and put it on the guide pins.	
4	<p>If the axis-3 motor is installed to the upper arm: In order to release the brakes, connect the 24 VDC power supply. Connect to R2.MP3-connector:</p> <ul style="list-style-type: none"> • + = pin 2 • - = pin 5 <p>Use the rotation tool and rotate the axis-3 motor to find the correct position for the guide pins in the lower arm.</p>	24 VDC power supply Rotation tool
5	<p>If the axis-3 motor is not installed to the upper arm: Use the pinion to rotate the axis-3 gearbox to find the correct position for the guide pins in the lower arm.</p>	Pinion: 3HAC067546-001 i 3HAC067547-001 ii 3HAC067545-001 iii
6	Insert 22 of the 24 M12 screws and washers.	 <p>xx1300002246</p>

Continues on next page

4 Repair

4.5.1 Replacing the upper arm

Continued

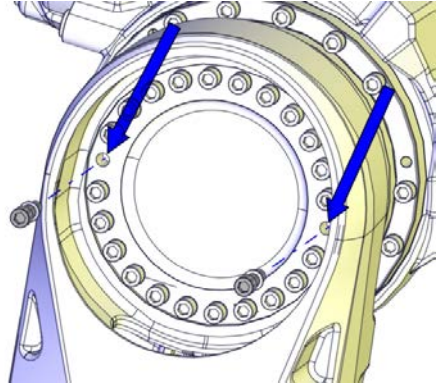
Action	Note
7 Remove the guide pins and fit the two remaining screws and washers.	 xx1300002245
8 Secure the upper arm by tightening the attachment screws.	M12, tightening torque: 120 Nm

i IRB 6700 - 235/2.65, IRB 6700 - 205/2.80, IRB 6700 - 175/3.05, IRB 6700 - 150/3.20

ii IRB 6700 - 200/2.60, IRB 6700 - 155/2.85

iii IRB 6700 - 300/2.70, IRB 6700 - 245/3.00

Securing the upper arm - IRB 6700 - 300/2.70, IRB 6700 - 245/3.00

Action	Note
<p>1  CAUTION</p> <p>The weight of the complete upper arm (including the wrist) is 360 kg (IRB 6700 -235/2.65, -205/2.80, -175/3.05, -150/3.20, -200/2.60, -155/2.85) 465 kg (IRB 6700 -300/2.70, -245/3.00) All lifting accessories used must be sized accordingly.</p>	
2 Attach the lifting accessories, if not already fitted.	See Attaching lifting accessories to the upper arm on page 216 .
3 Lift the upper arm and bring it towards the lower arm.	
4 If the axis-3 motor is installed to the upper arm: Connect the 24 VDC power supply, to release the brakes. Connect to R2.MP3-connector: <ul style="list-style-type: none"> • + = pin 2 • - = pin 5 Use the rotation tool and rotate the axis-3 motor to find the correct position for the guide pins in the lower arm. Disconnect and remove the 24 VDC power supply after finding the position.	24 VDC power supply Rotation tool
5 If the axis-3 motor is not installed to the upper arm: Use the pinion to rotate the axis-3 gearbox to find the correct position for the guide pins in the lower arm.	Pinion: 3HAC067546-001 ⁱ 3HAC067547-001 ⁱⁱ 3HAC067545-001 ⁱⁱⁱ

Continues on next page

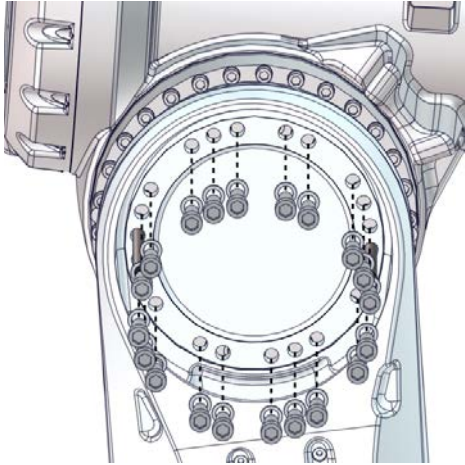
	Action	Note
6	Insert and tighten 20 of the 22 M16 screws.	 <p>xx170000057</p>
7	Remove the guide pins and fit the two remaining screws.	
8	Secure the upper arm by tightening the attachment screws.	M16, tightening torque: 300 Nm

- i IRB 6700 - 235/2.65, IRB 6700 - 205/2.80, IRB 6700 - 175/3.05, IRB 6700 - 150/3.20
- ii IRB 6700 - 200/2.60, IRB 6700 - 155/2.85
- iii IRB 6700 - 300/2.70, IRB 6700 - 245/3.00

Refitting the cable harness - upper arm

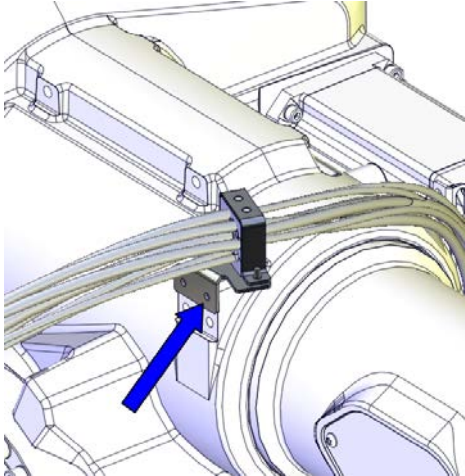

	Action	Note
1	Refit the metal clamp on top of the arm house.	 <p>xx1300000541</p>

Continues on next page

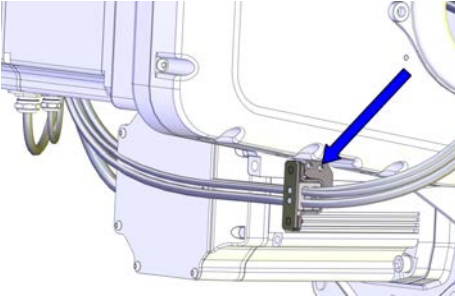

4 Repair

4.5.1 Replacing the upper arm

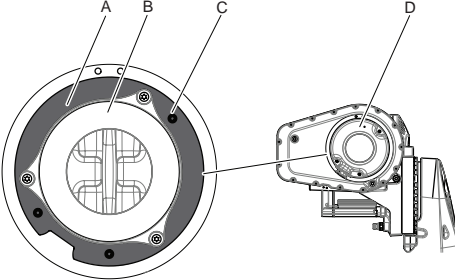
Continued

	Action	Note
2	Refit the arm house metal clamp.	 <p>xx130000543</p>
3	Arrange the cables between the cable clamps in the upper arm.	
4	 Tip Use tape and tie the axis-5 and axis-6 connectors and carrier into a bundle (if not already done). This is done to facilitate the procedure and to avoid damaging the parts during the procedure. This will also make it easier to run the cable harness through the inside of the robot.	 <p>xx130000668</p>
5	Foundry Plus: Make sure that the gasket underneath the cover is correctly fitted. Replace if damaged. The gasket is covered with adhesive on the side facing the upper arm cover. The three washers are pressed into the holes in the gasket. Make sure all three washers are fitted.	 <p>xx140000382</p> <p>A Gasket B Cable guide C Washer D Cover</p>

Continues on next page

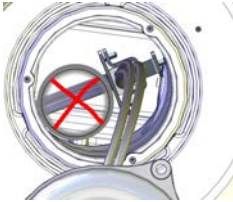
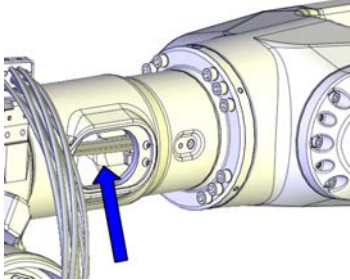
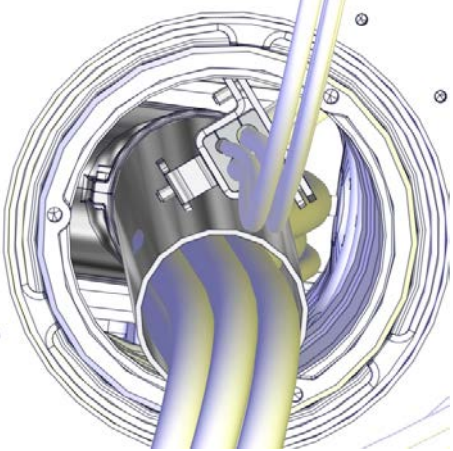

	Action	Note
6	<p>Run the cable harness through the cable guide and then into and through the upper arm tube.</p> <p> Tip</p> <p>This step is best performed by two persons working together:</p> <ul style="list-style-type: none"> • Person 1: Put one hand inside the side hole of the arm tube and take a hold of the cable harness. • Person 2: Take a hold on the cable harness at the back of the robot. • Together: Use caution and move the cable harness into the arm tube. <p> Note</p> <p>The cable harness is best placed at the upper right hand side of the DressPack tube, if used, through the arm tube.</p> <p>Do not run the cable harness into the DressPack tube!</p> <p> Note</p> <p>Do not run the cable harness into the DressPack tube, if one is fitted!</p> <p></p> <p>xx130000820</p>	<p>Person 1, working at the side hole:</p> <p></p> <p>xx130000745</p> <p>Person 2, working at the back:</p> <p></p> <p>xx140000356</p>

Continues on next page

4 Repair

4.5.1 Replacing the upper arm

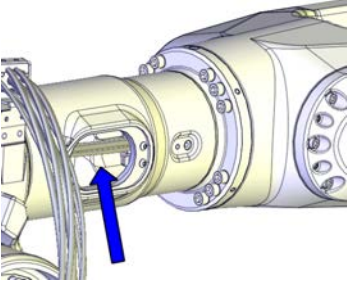
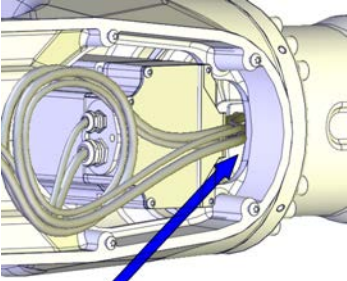
Continued

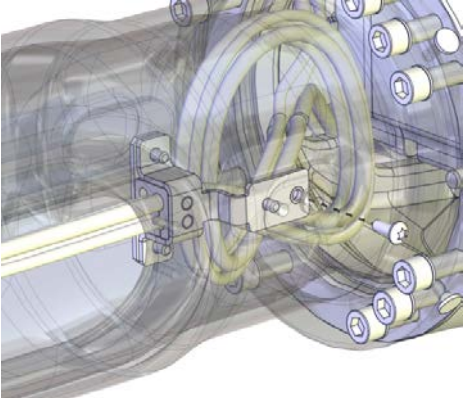
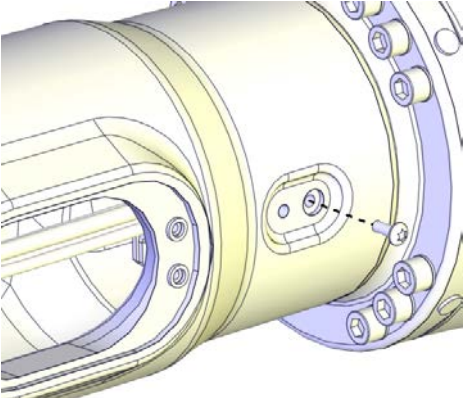
	Action	Note
7	<p>Use caution and push the cable harness into the wrist.</p> <p> Tip</p> <p>This step is best performed by two persons working together:</p> <ul style="list-style-type: none">• Person 1: Put one hand inside the side cover hole and take a hold of the cable harness.• Person 2: Take a hold of the cable harness from inside the wrist.• Together: Move the cable harness past the axis-5 motor and into the wrist.	<p>Person 1, working at the side hole:</p>  <p>xx130000745</p> <p>Person 2, working at the wrist:</p>  <p>xx130000746</p>
8	<p>Refit the metal clamp axis-4, inside the arm tube.</p> <p> Note</p> <p>The screws are reached from outside the upper arm.</p>	 <p>xx170000340</p>  <p>xx170000339</p>

Continues on next page

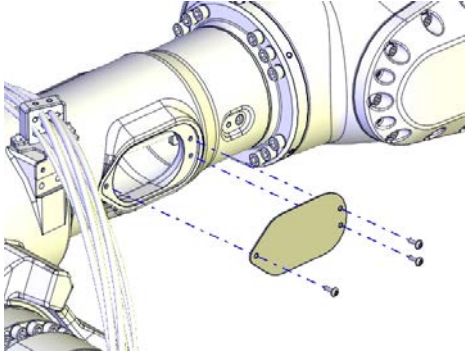
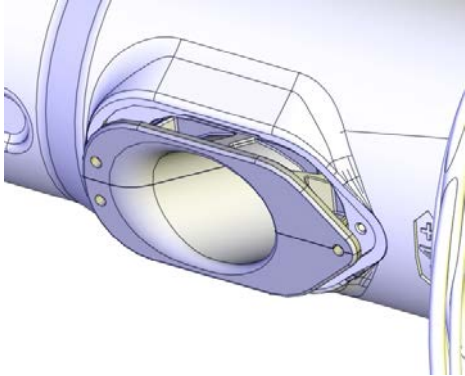
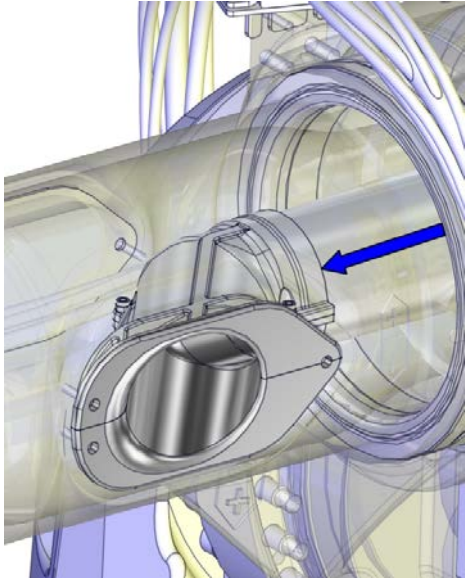

	Action	Note
9	<p>Refit the side cover.</p> <p> Note</p> <p><i>Foundry Plus:</i></p> <ul style="list-style-type: none"> • Make sure the gasket is fitted correctly on the side cover • Use attachment screws made of stainless steel to fit the side cover. 	 <p>xx130000557</p>
10	<p>If used, refit the insert that guides the DressPack cable package through the hole in the upper arm.</p>	 <p>xx170000690</p>
11	<p>If used, refit the tube containing the DressPack into the insert.</p>	 <p>xx140000092</p>

Continues on next page

4 Repair

4.5.1 Replacing the upper arm

Continued

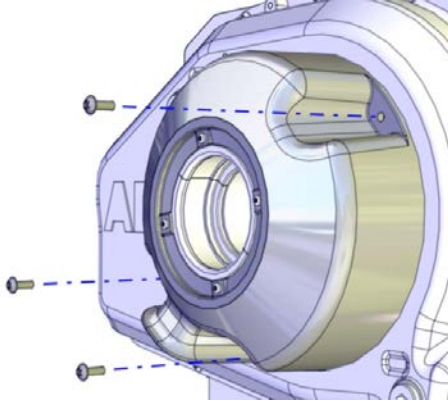
	Action	Note
12	Fit the cover insert around the new cabling and secure it with a weatherstrip.	<p>Cover insert: 3HAC048520-001.</p>  <p>xx1700001803</p> <p>Weatherstrip: 3HAC053986-001.</p>  <p>xx1700001804</p>
13	<p><i>DressPack or Foundry Plus:</i> Refit the cover with the tube guiding ring fitted.</p> <p> Note</p> <p><i>Foundry Plus:</i></p> <ul style="list-style-type: none">• Make sure the gasket is fitted correctly• Use attachment screws made of stainless steel to fit the cover.	 <p>xx120000045</p>

Continues on next page

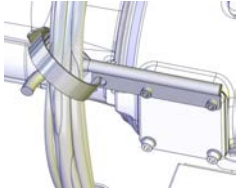
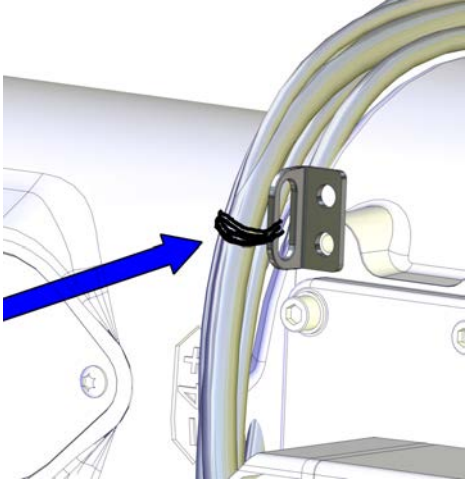
	Action	Note
14	<p>Secure the cable harness to the cable fixing bracket with a cable tie.</p> <p> Note</p> <p>If DressPack is fitted, the cable fixing bracket is replaced by the cable guide.</p>  <p>xx1300001973</p>	 <p>xx130000544</p>

Refitting the DressPack cable package

If used, refit the DressPack cable package. How to refit the DressPack cable package is described in more detail in the product manual "IRB 6700 DressPack". For article number see [References on page 10](#).

Connecting the axis-3 and axis-4 motor cables

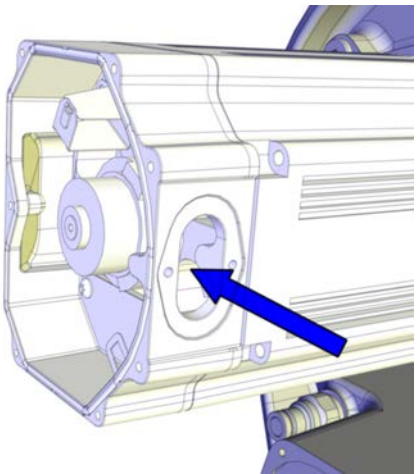

	Action	Note
1	<p>Push the motor cables through the cable gland opening.</p>	 <p>xx130000738</p>

Continues on next page



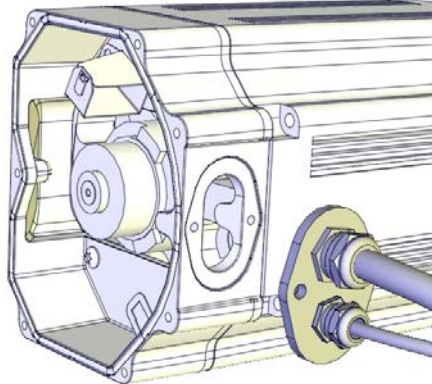
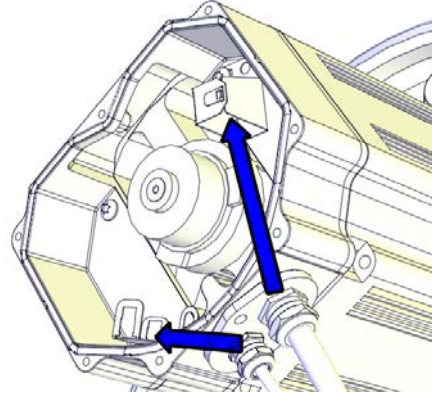

4 Repair

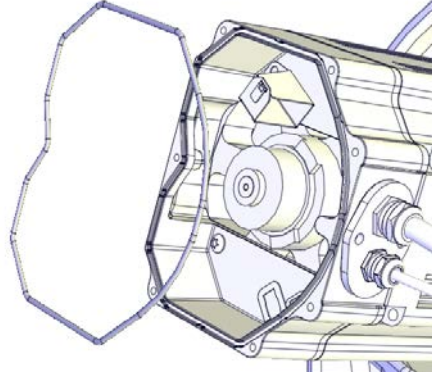
4.5.1 Replacing the upper arm

Continued

	Action	Note
2	Refit the cable gland cover.  Note Replace the gasket if damaged.	 xx1200001067
3	Connect the motor cables. Connect in accordance with the markings on the connectors.	 xx1200001066
4	Inspect the o-ring.  Note Replace if damaged.	O-ring, axis-1: 3HAB3772-111 (circular profile) / 3HAC054692-002 (hexagon profile) O-ring, axis-2: 3HAB3772-111 (circular profile) / 3HAC054692-002 (hexagon profile) O-ring, axis-3: 3HAB3772-111 (circular profile) / 3HAC054692-002 (hexagon profile) O-ring, axis-4: 3HAB3772-110 (circular profile) / 3HAC054692-001 (hexagon profile)  xx1200001070

Continues on next page

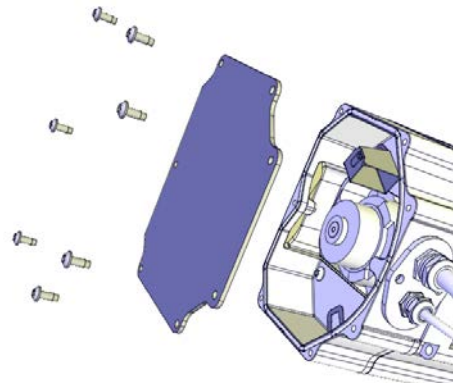
	Action	Note
5	Wipe clean o-ring and o-ring groove.	
6	Refit the o-ring.  Tip Lubricate the o-ring with some grease for a better fitting in the groove.	
7	 CAUTION When fitting the motor cover, make sure that none of the cables inside will be damaged.	
8	Refit the motor cover with it's attachment screws.  Note Do not reuse the self-threading attachment screws. Replace with standard attachment screws or the threads will be damaged.  Note Make sure the o-ring is undamaged and properly fitted.	Attachment screws: M5x12 8.8 (7 pcs)  xx1200001135
9	Make sure that the covers are tightly sealed.	

Connecting the axis-5 motor cables

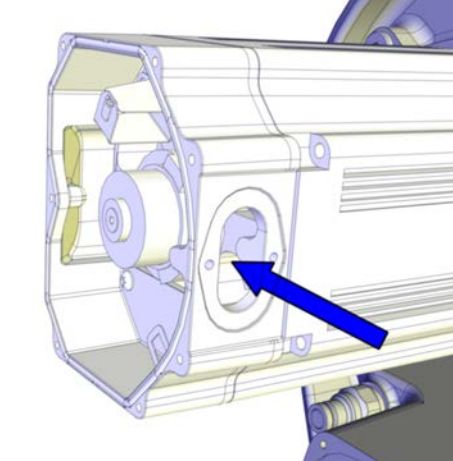

	Action	Note
1	Push the motor cables in through the cable gland opening.	 xx1300000738

Continues on next page



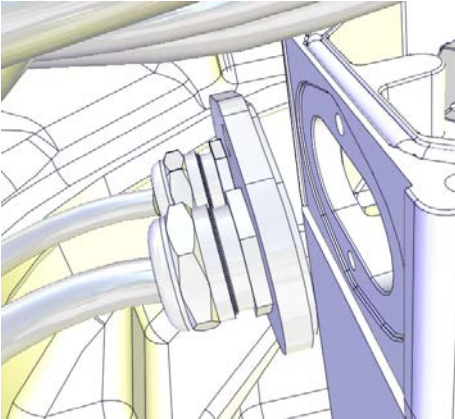
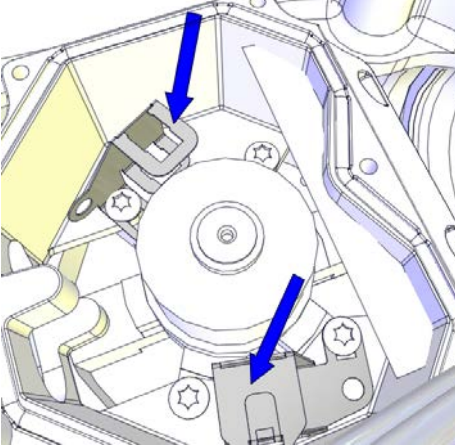
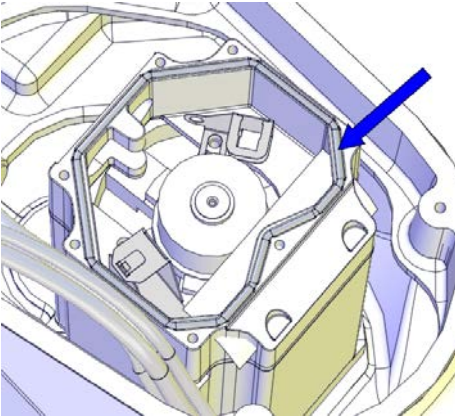

4 Repair

4.5.1 Replacing the upper arm

Continued

	Action	Note
2	<p>Refit the cable gland cover by performing the following steps:</p> <ul style="list-style-type: none"> • Slide the cable gland cover onto the inner screw. • Refit and tighten the outer screw. • Tighten the inner screw. Make sure that the gasket is not damaged. <p> Note</p> <p>Replace the gasket if damaged.</p>	 <p>xx1200001016</p>
3	<p>Connect the connectors. Connect in accordance with the markings on the connectors.</p>	 <p>xx1200001015</p>
4	<p>Make sure the o-ring on the motor is undamaged. Replace if damaged.</p>	<p>O-ring, axis 5: 3HAB3772-110 (circular profile) / 3HAC054692-001 (hexagon profile).</p>  <p>xx1200001021</p>
5	<p> CAUTION</p> <p>When fitting the motor cover, make sure that none of the cables inside will be damaged.</p>	

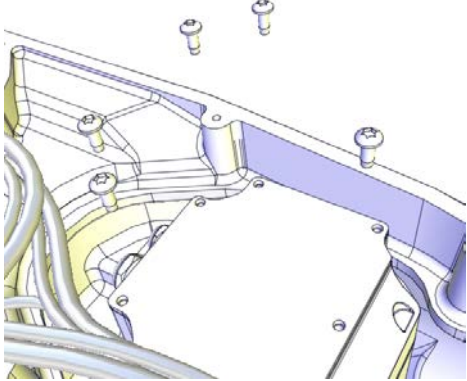
Continues on next page

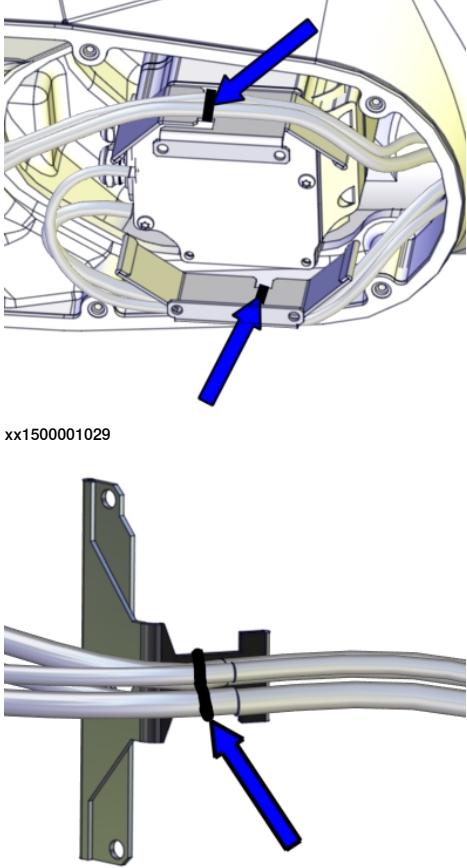
	Action	Note
6	<p>Refit the motor cover with its attachment screws.</p> <p> Note</p> <p>Do not refit the screws that will hold the heat protection plate at this point.</p> <p> Note</p> <p>Do not reuse the self-threading attachment screws, it will damage the threads. Replace with standard attachment screws.</p> <p> Note</p> <p>Make sure the o-ring is undamaged and properly fitted.</p>	<p>Screws: M5x12.</p>  <p>xx1200001013</p>
7	<p>Secure the cable harness with cable straps to the heat protection plate.</p> <p> Note</p> <p>If replacing a type A motor with a type B motor, the heat protection plate must be replaced with plates suited for the type B motor. See Type A vs type B motors on page 805.</p>	<p>There are two versions of the heat protection plates. Choose figure depending on which plate is installed on the robot.</p>  <p>xx1500001029</p> <p>xx1300000489</p>

Continues on next page

4 Repair

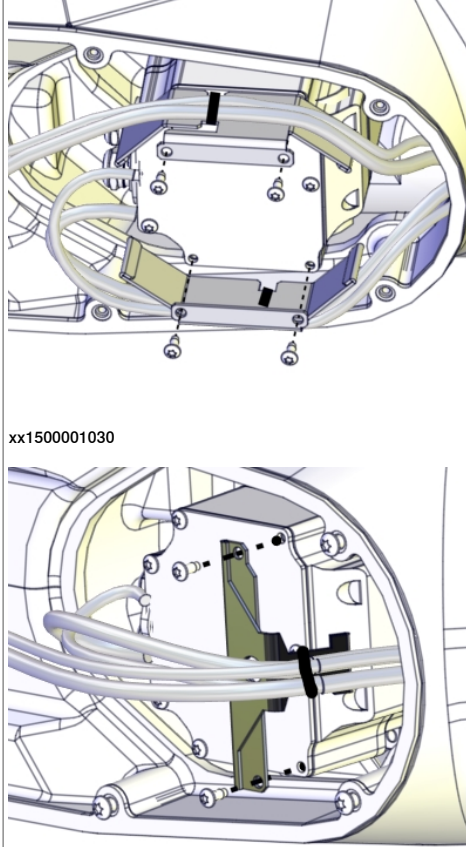

4.5.1 Replacing the upper arm

Continued

	Action	Note
8	Fit the heat protection plate with the screws.	<p>Choose figure depending on which plate is installed on the robot. Screws: M5x12.</p>  <p>xx1500001030</p> <p>xx1300000490</p>

Continues on next page

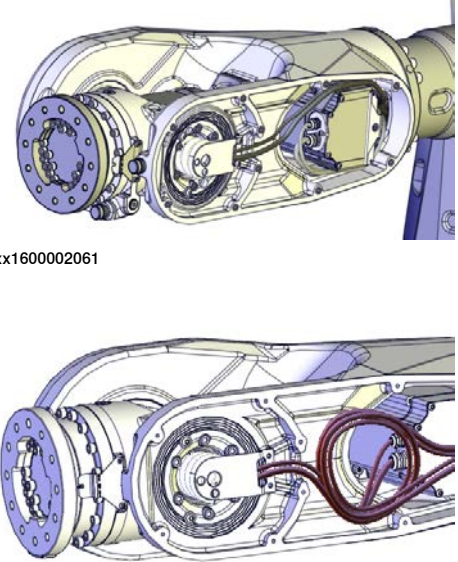
Connecting the axis-6 motor cables

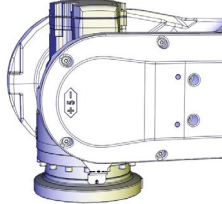
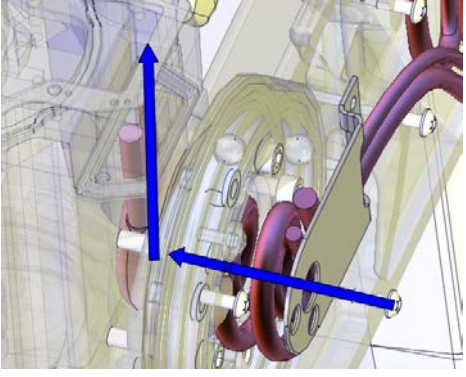

	Action	Note
1	<p>Make sure that the cable harness is placed in a way that it will not be damaged when the cover is fitted.</p>	 <p>xx1600002061</p> <p>xx130000596</p> <p>Cable layout in the wrist with Type A motors.</p>
2	<p> Note</p> <p>Axis 5 must be in position +90° (or as close as possible) for a correct installation of the cable harness in the wrist. If not, connect the 24 VDC power supply, release the brakes and move axis 5 manually to +90°.</p>	 <p>xx1200001081</p>
3	<p>Push the cable harness into the wrist recess and up into the axis-6 motor.</p>	 <p>xx130000667</p>

Continues on next page

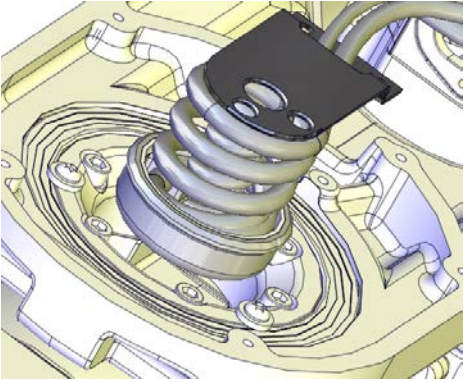

4 Repair

4.5.1 Replacing the upper arm

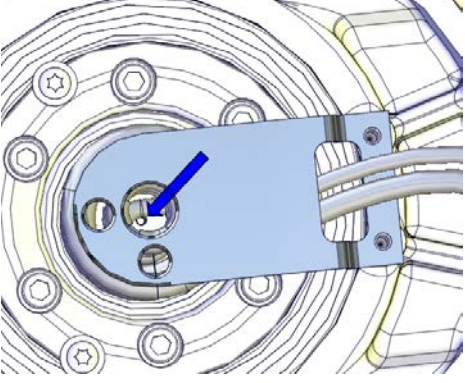
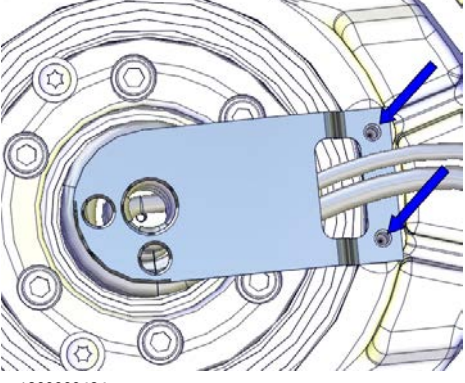
Continued

	Action	Note
4	Push the carrier carefully into position.	 xx1300001113
5	<p>Secure the carrier with the M4 screw.</p> <p> Note</p> <p>The screw is located at the bottom of the carrier.</p> <p> Tip</p> <p>The attachment screw securing the carrier may be difficult to fit. Make sure the carrier is level and completely pressed against the bottom.</p>	 xx1300000485
6	Secure the cable bracket with its attachment screws.	 xx1300000484

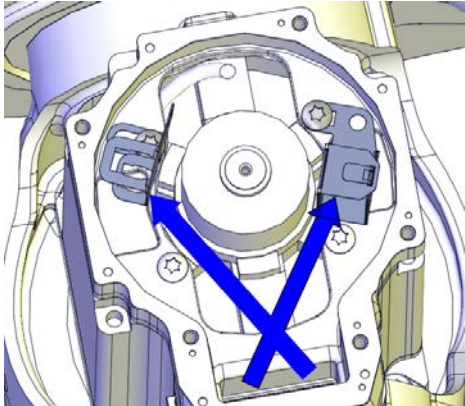
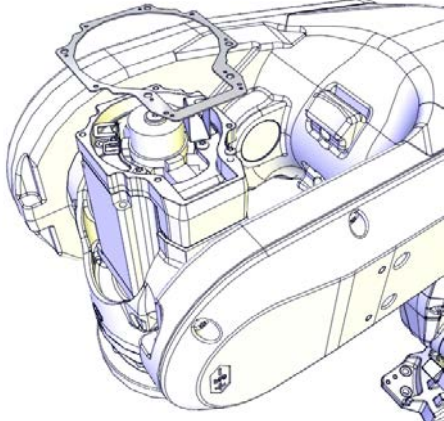
Continues on next page

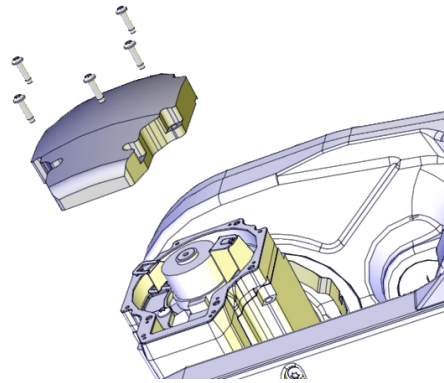
	Action	Note
7	<p>Reconnect the connectors to the axis-6 motor.</p> <p> Note</p> <p>Place the resolver cable under the motor cable.</p>	 <p>xx130000488</p>
8	<p>Make sure the gasket is undamaged. Replace if damaged.</p>	<p>Gasket, 3HAC033489-001/ 3HAC044252-001</p>  <p>xx1200001095</p>
9	<p> CAUTION</p> <p>When fitting the motor cover, make sure that none of the cables inside will be damaged.</p>	
10	<p>Refit the motor cover.</p>	 <p>xx1200001080</p>

Continues on next page

4 Repair

4.5.1 Replacing the upper arm

Continued

Refitting the wrist cover

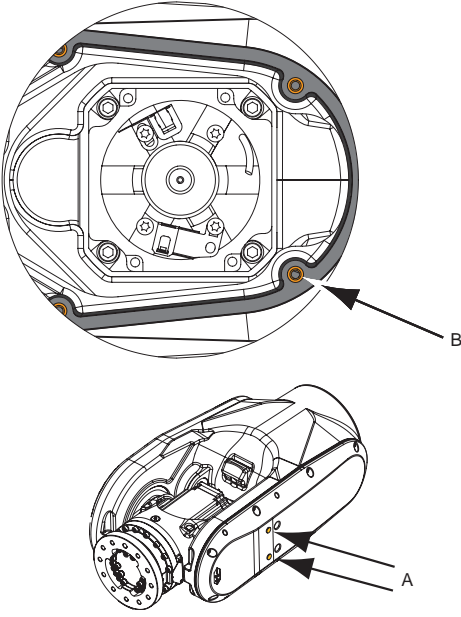
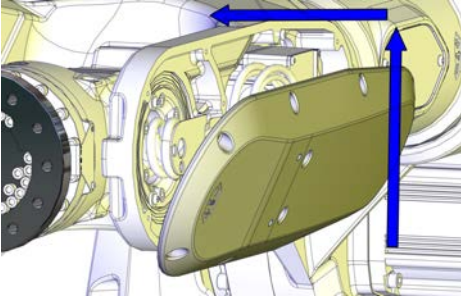
	Action	Note
1	<p>Foundry Plus: Inspect the gasket. Replace if damaged. Put washers in the holes of the gasket.</p>	 <p>xx140000383</p> <p>A Protection plugs (2 on wrist cover and 2 on cover axis-5 gearbox) B Washers (10 pcs) in gasket holes</p>
2	<p>Refit the wrist cover. In order not to damage the cable harness when the wrist cover is refitted, use this method:</p> <ol style="list-style-type: none"> 1 Hold the cover angled. See figure! 2 Catch any part of the cable harness hanging down. 3 Lift the cover, still held in an angle. 4 Move the upper part of the cover into position. 5 Secure the cover with its attachment screws. 	 <p>xx130000772</p> <p>Tightening torque: 10 Nm.</p>
3	Remove the lifting accessories.	

Concluding procedure

	Action	Note
1	Re-calibrate the robot.	<p>Pendulum Calibration is described in <i>Operating manual - Calibration Pendulum</i>, enclosed with the calibration tools.</p> <p>Axis Calibration is described in Calibrating with Axis Calibration method on page 781.</p> <p>General calibration information is included in section Calibration on page 767.</p>
2	 <p>DANGER</p> <p>Make sure all safety requirements are met when performing the first test run.</p>	

4.5.2 Replacing the wrist

Strictly forbidden to open the cover on the axis-5 gearbox



Note

Do not, under any circumstances, open the cover on the axis-5 gearbox! It is strictly forbidden to do any repair work on the axis-5 gearbox.

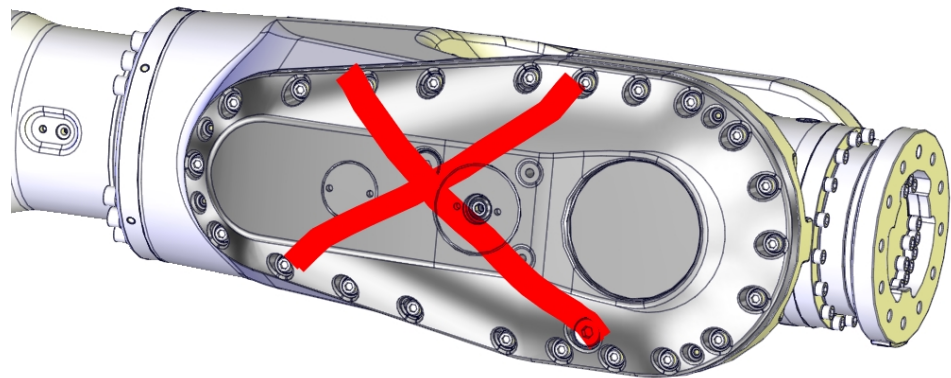

xx1300002248

Location of the wrist

The wrist is located as shown in the figure.

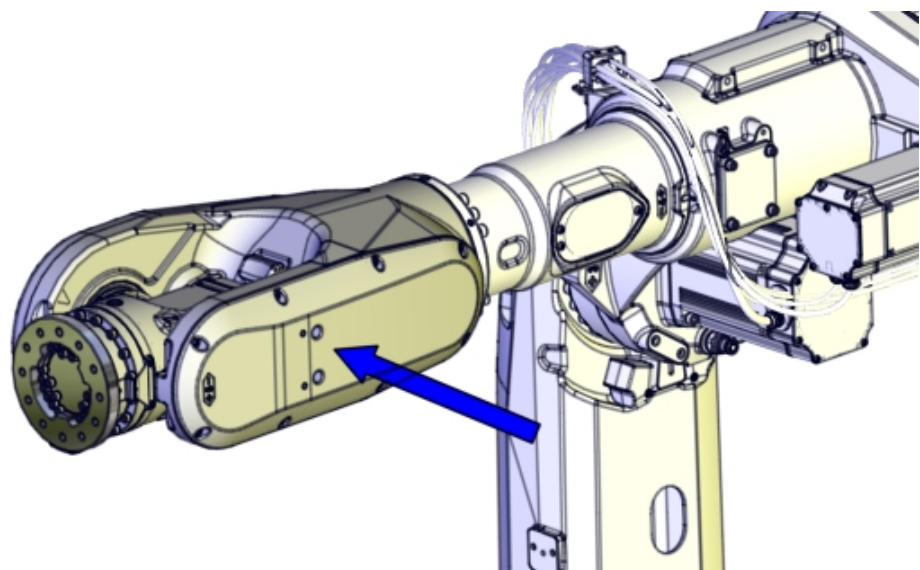

xx130000597

Continues on next page

4 Repair

4.5.2 Replacing the wrist

Continued

Spare part

Spare part	Spare part number	Note
Wrist	See <i>Product manual, spare parts - IRB 6700/IRB 6700Inv.</i> <i>Product manual, spare parts - IRB 6790</i>	

Consumables

Equipment, etc.	Article number	Note
Cable tie	-	
Grease	3HAC042536-001	Shell Gadus S2 Used to lubricate o-rings.
O-ring	3HAB3772-110 (circular profile) / 3HAC054692-001 (hexagon profile)	D=119x3 Used on axis-5 motor cover.
Gasket	3HAC033489-001/ 3HAC044252-001	Used on axis-6 motor cover.
Rust preventive	3HAC034903-001	Mercasol 3110 Waxcoat. Recommended drying time is 24h. Used on Foundry Plus.

Required tools and equipment

Equipment, etc.	Article number	Note
Roundsling, 1 m	-	Length: 1 m, lifting capacity: 1,000 kg.
Pallet		Used for putting down removed parts from robot.
Cardboard		Used for protection.
Guide pin, M12x150	3HAC13056-2	Always use guide pins in pairs.
24 VDC power supply	-	Used to release the motor brakes.
Calibration Pendulum toolkit	3HAC15716-1	Required if Calibration Pendulum is the valid calibration method for the robot.
Calibration tool box, Axis Calibration	3HAC055412-001	Delivered as a set of calibration tools. Required if Axis Calibration is the valid calibration method for the robot.
Standard toolkit	-	Content is defined in section Standard toolkit on page 814 .

Continues on next page

Deciding calibration routine

Decide which calibration routine to be used, based on the information in the table. Depending on which routine is chosen, action might be required prior to beginning the repair work of the robot, see the table.

	Action	Note
1	Decide which calibration routine to use for calibrating the robot. <ul style="list-style-type: none"> Reference calibration. External cable packages (DressPack) and tools can stay fitted on the robot. Fine calibration. All external cable packages (DressPack) and tools must be removed from the robot. 	
	If the robot is to be calibrated with reference calibration: Find previous reference values for the axis or create new reference values. These values are to be used after the repair procedure is completed, for calibration of the robot. If no previous reference values exist, and no new reference values can be created, then reference calibration is not possible.	Follow the instructions given in the reference calibration routine on the FlexPendant to create reference values. Creating new values requires possibility to move the robot. Read more about reference calibration for Axis Calibration in Reference calibration routine on page 782 . Read more about reference calibration for Pendulum Calibration in <i>Operating manual - Calibration Pendulum</i> .
	If the robot is to be calibrated with fine calibration: Remove all external cable packages (DressPack) and tools from the robot.	

Removing the wrist

These procedures describes how to remove the wrist.

Preparations before removing the wrist



	Action	Note
1	Decide which calibration routine to use, and take actions accordingly prior to beginning the repair procedure.	
2	Remove tools and other equipment fitted to the wrist.	

Continues on next page

4 Repair

4.5.2 Replacing the wrist

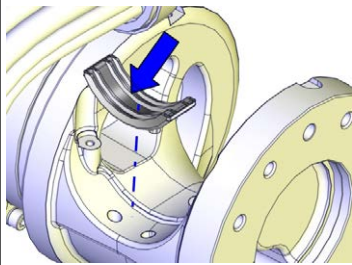
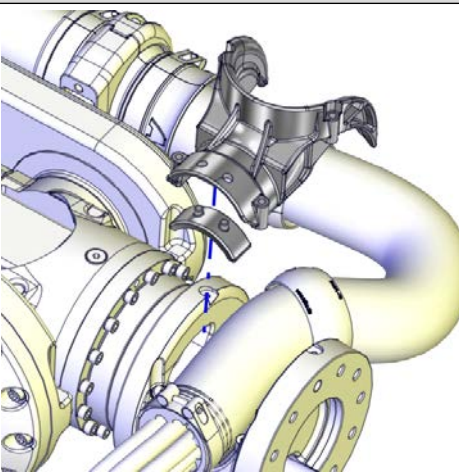
Continued

	Action	Note
3	<p>If used, open the DressPack axis-6 cable support and remove the DressPack cable package from the process turning disk.</p> <p> Note</p> <p>Use caution not to lose the two clamp jaws on either side of the DressPack cable package.</p>  <p>xx1400000223</p> <p>Clamp jaw</p>	 <p>xx1400000208</p>
4	<p>Jog the robot into position:</p> <ul style="list-style-type: none"> • Axis 1: no significance (as long as the robot is secured to the foundation) • Axis 2: -60° • Axis 3: +60° • Axis 4: +90° • Axis 5: +90° • Axis 6: no significance 	
5	<p> DANGER</p> <p>Turn off all:</p> <ul style="list-style-type: none"> • electric power supply • hydraulic pressure supply • air pressure supply <p>to the robot, before entering the safeguarded space.</p>	
6	<p>Prepare a pallet with cardboard in front of the robot or where it is possible, to be used for putting down the wrist unit on.</p>	

Retrieving access to the wrist cabling

Use this procedure to remove the wrist cover to retrieve access to the axis-5 and axis-6 motor cables.

	Action	Note
1	<p> DANGER</p> <p>Make sure that all supplies for electrical power, hydraulic pressure, and air pressure are turned off.</p>	

Continues on next page

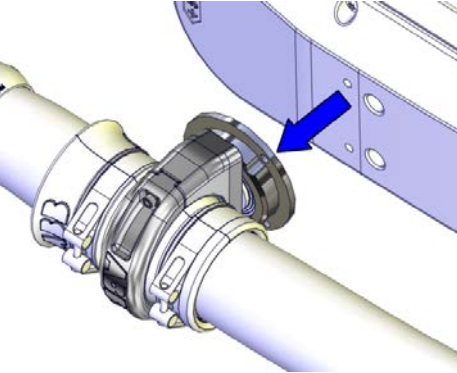
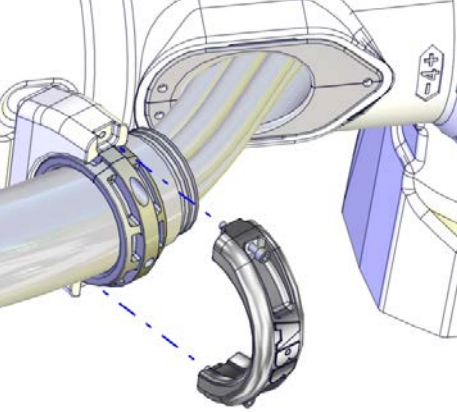
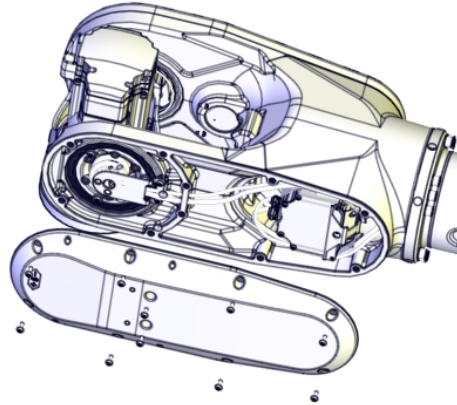
	Action	Note
2	<p>If DressPack is installed:</p> <ul style="list-style-type: none"> Remove the bracket with the complete ball joint housing still fitted, as shown in the figure. <p>This is done to be able to reach the two hidden screws that secure the wrist cover.</p>	 <p>xx140000355</p>
3	<p>If used, open the ball joint housing on the arm tube and remove the DressPack cable package.</p>	 <p>xx140000206</p>
4	<p>Remove the wrist cover.</p>	 <p>xx130000247</p>

Continues on next page



4 Repair

4.5.2 Replacing the wrist

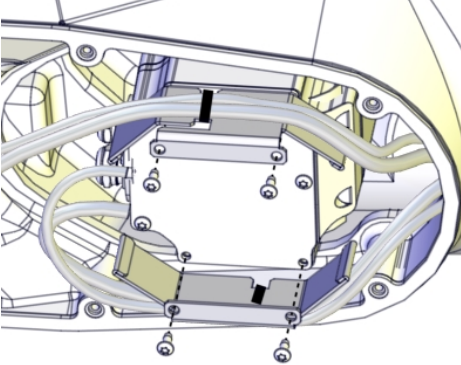
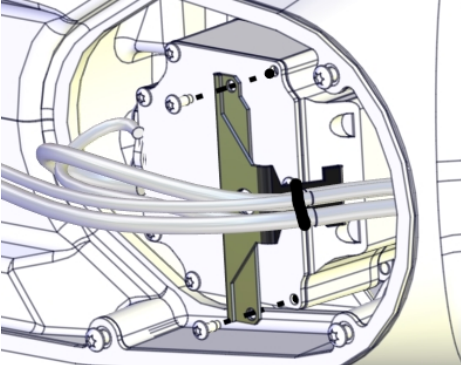
Continued

	Action	Note
5	<p>Remove the heat protection plate/plates from the motor with the cabling still attached to the plate.</p> <p>Remove the heat protection plates from the motor with the cabling still attached to the plate.</p>	<p>There are two versions of the heat protection plates.</p> <p>Choose figure depending on which plate is installed on the robot.</p>  <p>xx1500001030</p>  <p>xx1300000490</p>

Continues on next page

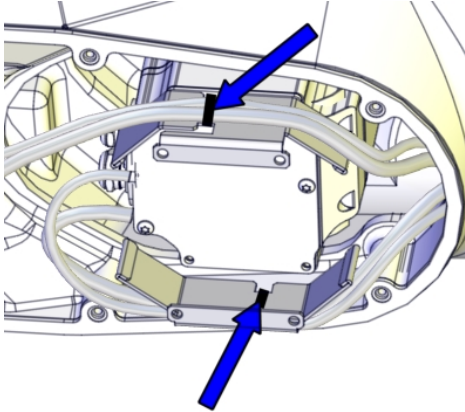
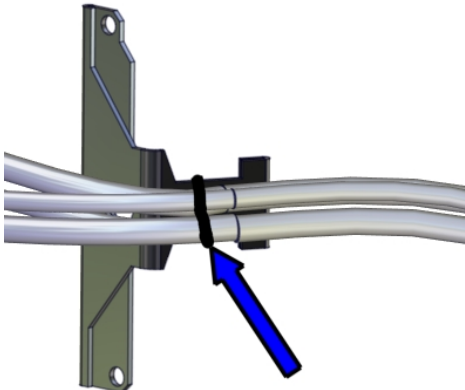
	Action	Note
6	<p>Cut the cable ties that hold the cable harness to the plate.</p> <p> Note</p> <p>Keep the heat protection plate until refitting.</p> <p> Tip</p> <p>If removing the plate only for replacing the motor, the cabling does not need to be loosened from the plate.</p>	<p>Choose figure depending on which plate is installed on the robot.</p>  <p>xx1500001029</p>  <p>xx1300000489</p>

Disconnecting the axis-6 motor cables

	Action	Note
1	<p> DANGER</p> <p>Make sure that all supplies for electrical power, hydraulic pressure, and air pressure are turned off.</p>	

Continues on next page

4 Repair

4.5.2 Replacing the wrist

Continued

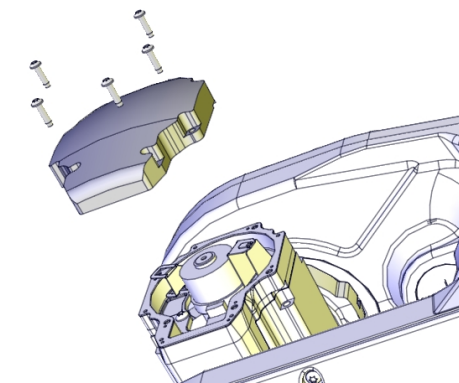
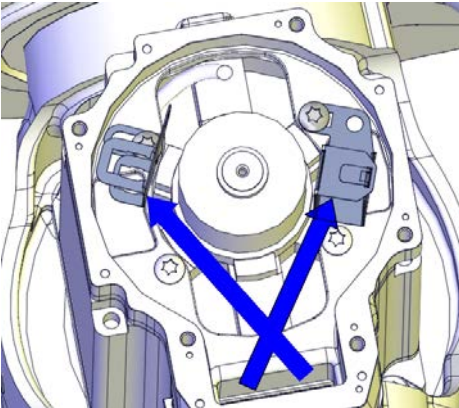
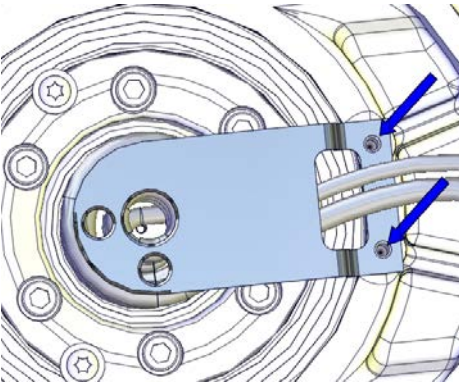
	Action	Note
2	Unscrew the attachment screws and remove the motor cover.	 xx1200001080
3	Disconnect the motor cables.	 xx1300000488
4	Unscrew the attachment screws that hold the cable bracket.	 xx1300000484

Continues on next page

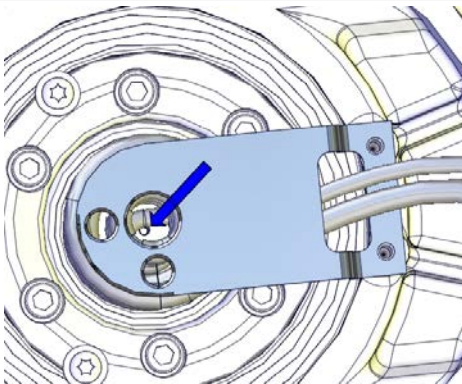
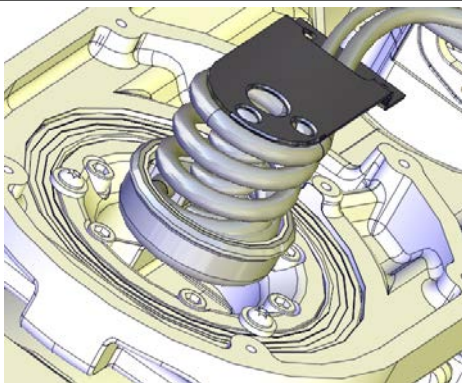
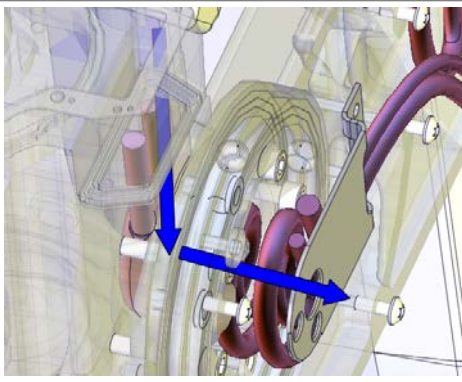
	Action	Note
5	<p>Unscrew the M4 screw that holds the carrier.</p> <p> Note</p> <p>The screw is located at the bottom of the carrier.</p>	 <p>xx130000485</p>
6	<p>Pull out the carrier from its position.</p>	 <p>xx1300001113</p>
7	<p>Pull out the axis-6 motor cables by holding the cables with one hand at the motor and the other at the carrier.</p>	 <p>xx130000666</p>

Disconnecting the axis-5 motor cables

	Action	Note
1	<p> DANGER</p> <p>Make sure that all supplies for electrical power, hydraulic pressure, and air pressure are turned off.</p>	

Continues on next page

4 Repair

4.5.2 Replacing the wrist



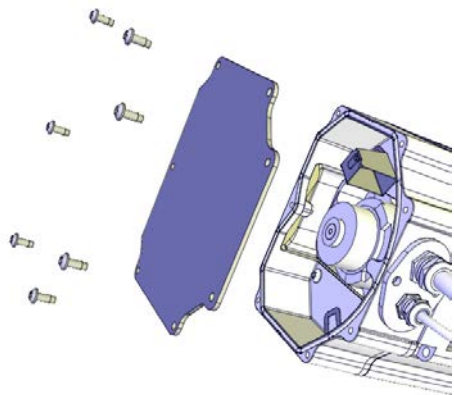
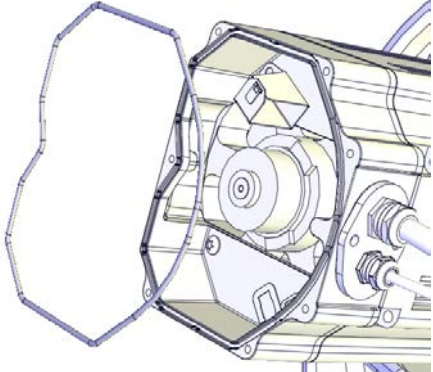
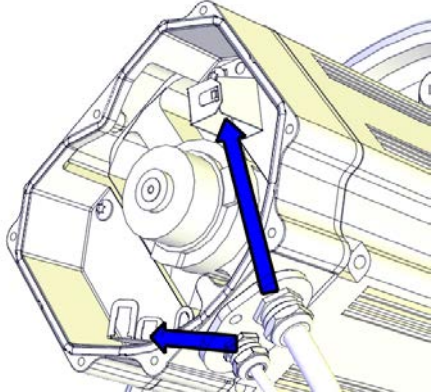

Continued

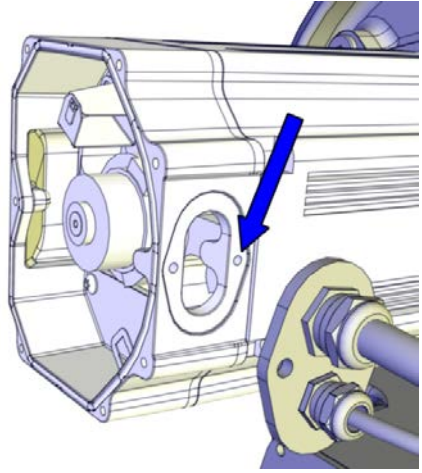
	Action	Note
2	Unscrew the attachment screws and washers and remove the motor cover.	 <p>xx1200001135</p>
3	Make sure the o-ring is present.	 <p>xx1200001070</p>
4	Disconnect the motor cables.	 <p>xx1200001066</p>

Continues on next page

	Action	Note
5	<p>Remove the cable gland cover by performing the following steps:</p> <ol style="list-style-type: none"> 1 Open the inner screw a little (the one the arrow is pointing at). No need to remove this screw from the motor. 2 Remove the outer screw. 3 Slide the cable gland cover away from the inner screw. Make sure the gasket is not damaged. <p> Tip</p> <p>Make a note in which direction the cable exit hole is facing, if the motor will be removed too. The motor shall be refitted in the same position.</p>	 <p>xx130000656</p>
6	Use caution and pull out the motor cables.	

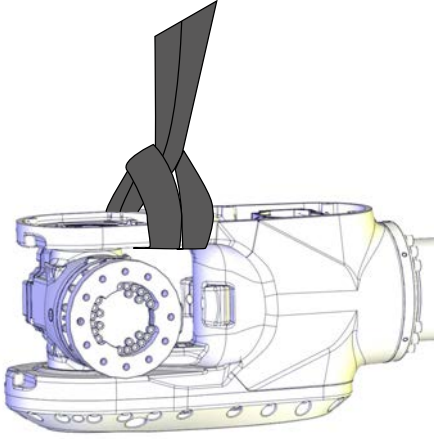
Attaching the lifting accessories to the wrist

	Action	Note
1	<p> CAUTION</p> <p>The weight of the complete wrist is 125 kg (IRB 6700 -235/2.65, -205/2.80, -175/3.05, -150/3.20, -200/2.60, -155/2.85) 140 kg (IRB 6700 -300/2.70, -245/3.00) All lifting accessories used must be sized accordingly.</p>	
2	<p>Attach a roundsling to the wrist as shown in the figure.</p> <p> CAUTION</p> <p>It is very important that the roundsling is placed as shown in the figure, to keep the wrist balanced when it is removed. Placed at a different position, there is a risk of sudden change in the balance, which can cause damage or injury.</p> <p>Do not attach the roundsling around the axis-5 gearbox!</p>	<p>Roundsling, 1 m: Length: 1 m, lifting capacity: 1,000 kg.</p>  <p>xx130000673</p>
3	<p> Note</p> <p>Make sure the roundsling is stretched, so it can carry the weight of the wrist.</p>	





Continues on next page

4 Repair

4.5.2 Replacing the wrist

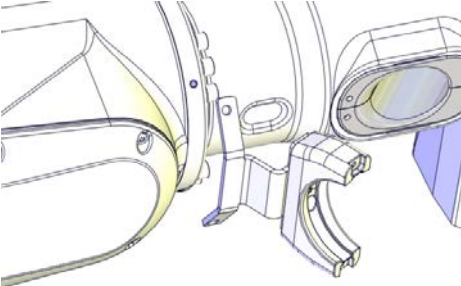
Continued

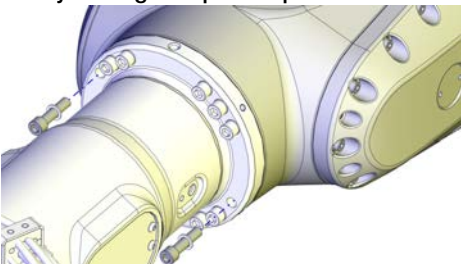
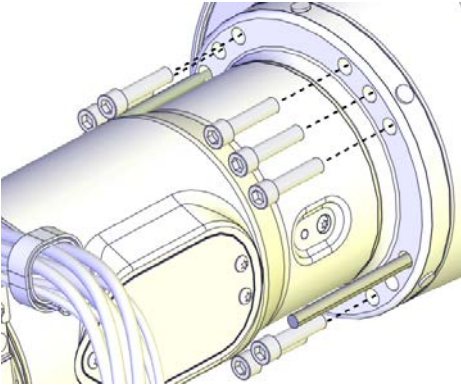
Removing the wrist

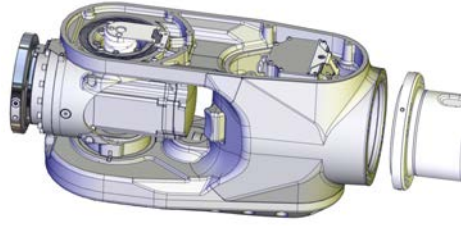
	Action	Note
1	If used, remove the bracket with the part of the ball joint housing still fitted.	 xx170000691
2	Remove two attachment screws in opposite holes and replace them with guide pins.  Tip Lubricate the guide pins with some grease to make the wrist slide better.	Guide pin, M12x150: 3HAC13056-2 Always use guide pins in pairs.  xx130000748
3	Remove the remaining attachment screws.	 xx130000749
4	Pull out the wrist a bit, onto the guide pins. This is done to be able to remove the cable harness from the wrist in a safe way.  CAUTION Make sure that the cabling does not get damaged.	 xx130000750

Continues on next page

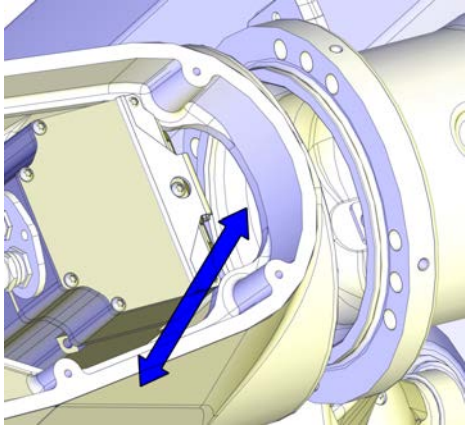
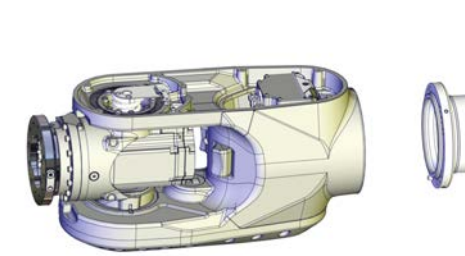
	Action	Note
5	Use caution and pull out the cabling from the wrist unit.	 <p>xx130000769</p>
6	Slide the wrist off the guide pins and put it on a pallet or similar.	 <p>xx130000770</p>

Refitting the wrist

These procedures describes how to refit the wrist.

Preparations before refitting the wrist



	Action	Note
1	 <p>DANGER</p> <p>Make sure that all supplies for electrical power, hydraulic pressure, and air pressure are turned off.</p>	
2	Wipe clean all contact surfaces.	

Continues on next page

4 Repair

4.5.2 Replacing the wrist

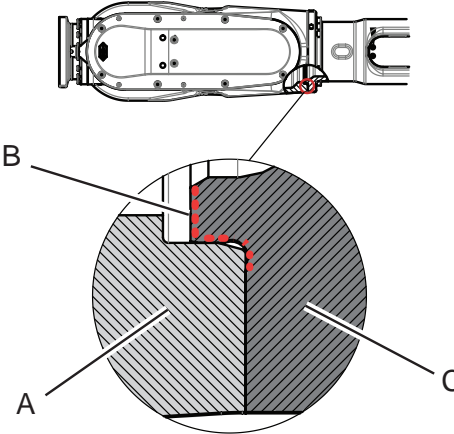

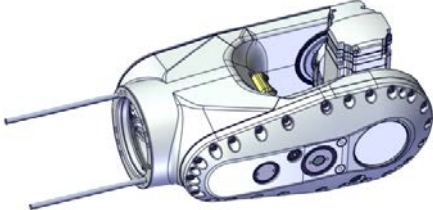
Continued

	Action	Note
3	<p>Foundry Plus: Apply Mercasol on the surfaces shown in the figure.</p>	 <p>xx1400000371</p>
4	<p>Fit two guide pins in opposite holes in the wrist.</p> <p> Tip Lubricate the guide pins with some grease to make the wrist slide better.</p>	<p>Guide pin, M12x150: 3HAC13056-2 Always use guide pins in pairs.</p>  <p>xx1700001595</p>
5	<p>If axis-5 is not already in position +90°, connect the 24 VDC power supply, release the brakes and move the axis manually into that position.</p> <p>Connect to R2.MP5-connector:</p> <ul style="list-style-type: none"> • + = pin 2 • - = pin 5 	<p>24 VDC power supply</p>

Attaching the lifting accessories to the wrist

	Action	Note
1	<p> CAUTION</p> <p>The weight of the complete wrist is 125 kg (IRB 6700 -235/2.65, -205/2.80, -175/3.05, -150/3.20, -200/2.60, -155/2.85) 140 kg (IRB 6700 -300/2.70, -245/3.00) All lifting accessories used must be sized accordingly.</p>	

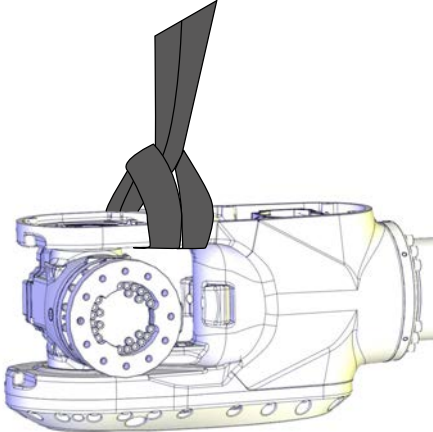
Continues on next page

	Action	Note
2	<p>Attach a roundsling to the wrist as shown in the figure.</p> <p> CAUTION</p> <p>It is very important that the roundsling is placed as shown in the figure, to keep the wrist balanced when it is removed. Placed at a different position, there is a risk of sudden change in the balance, which can cause damage or injury.</p> <p>Do not attach the roundsling around the axis-5 gearbox!</p>	<p>Roundsling, 1 m: Length: 1 m, lifting capacity: 1,000 kg.</p>  <p>xx130000673</p>
3	<p> Note</p> <p>Make sure the roundsling is stretched, so it can carry the weight of the wrist.</p>	

Refitting the wrist

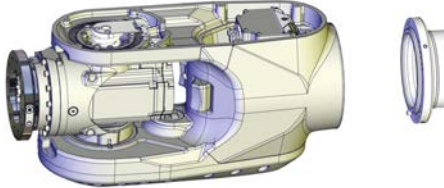
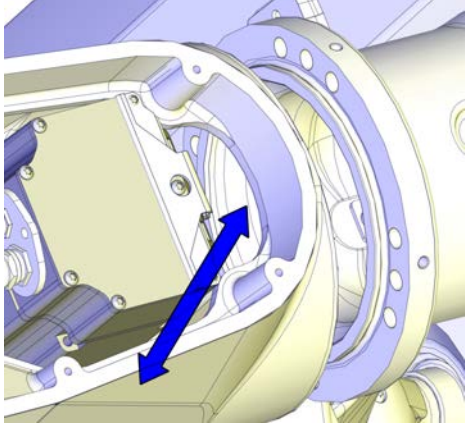
	Action	Note
1	<p>Lift the wrist and insert the guide pins into the holes of the arm tube.</p> <p> Tip</p> <p>Leave a small opening between wrist and arm tube. This will make it easier to run the cable harness back into the wrist.</p>	 <p>xx130000770</p>
2	<p>Run the cabling into the wrist unit. Be careful not to damage any part of the cable harness.</p>	 <p>xx130000769</p>

Continues on next page

4 Repair

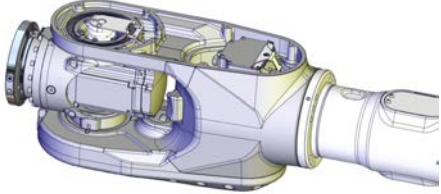
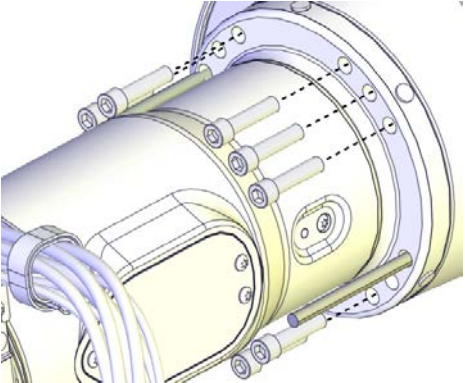
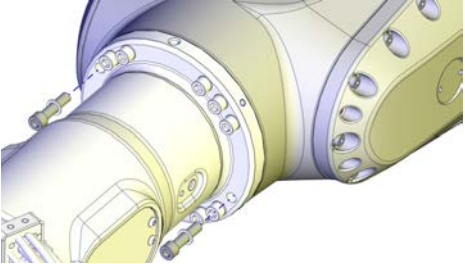

4.5.2 Replacing the wrist

Continued

	Action	Note
3	Mount the four sealing plate nuts on the tube shaft.	
4	Slide the wrist into fitting position.	 xx1300000771
5	Fit 10 of the 12 attachment screws and washers.	Screws: M12x50.  xx1300000749
6	Remove the guide pins and replace them with the remaining attachment screws and washers.	 xx1300000748
7	Tighten the attachment screws.	Tightening torque: 120 Nm.

Continues on next page

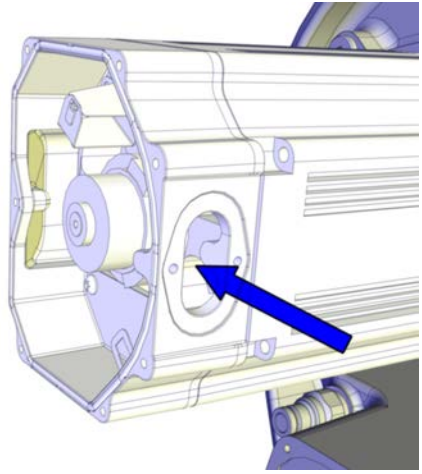
Connecting the axis-5 motor cables

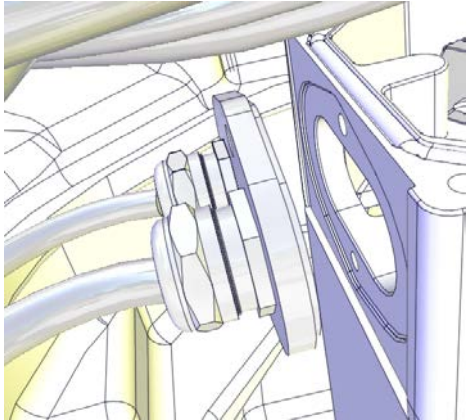
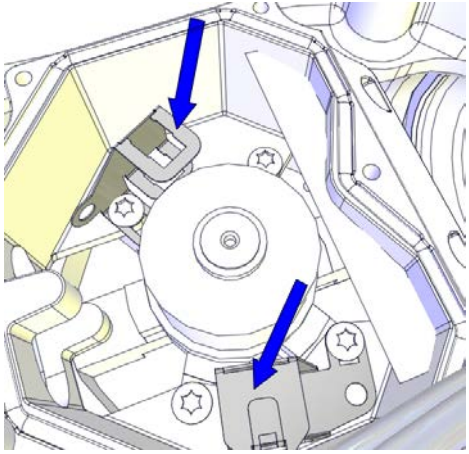



	Action	Note
1	<p>Push the motor cables in through the cable gland opening.</p>	 <p>xx130000738</p>
2	<p>Refit the cable gland cover by performing the following steps:</p> <ul style="list-style-type: none"> • Slide the cable gland cover onto the inner screw. • Refit and tighten the outer screw. • Tighten the inner screw. Make sure that the gasket is not damaged. <p> Note Replace the gasket if damaged.</p>	 <p>xx1200001016</p>
3	<p>Connect the connectors. Connect in accordance with the markings on the connectors.</p>	 <p>xx1200001015</p>

Continues on next page

4 Repair

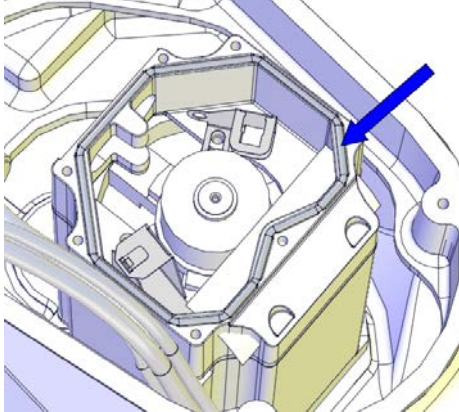
4.5.2 Replacing the wrist

Continued

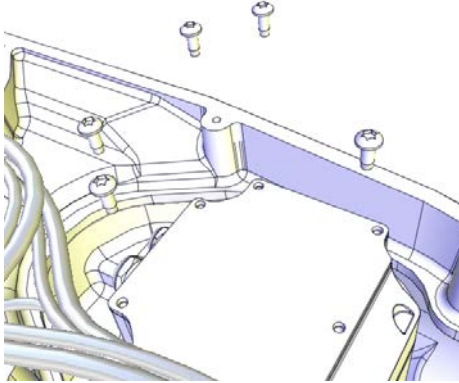
	Action	Note
4	<p>Make sure the o-ring on the motor is undamaged. Replace if damaged.</p>	<p>O-ring, axis 5: 3HAB3772-110 (circular profile) / 3HAC054692-001 (hexagon profile).</p>  <p>xx1200001021</p>
5	<p> CAUTION</p> <p>When fitting the motor cover, make sure that none of the cables inside will be damaged.</p>	
6	<p>Refit the motor cover with its attachment screws.</p> <p> Note</p> <p>Do not refit the screws that will hold the heat protection plate at this point.</p> <p> Note</p> <p>Do not reuse the self-threading attachment screws, it will damage the threads. Replace with standard attachment screws.</p> <p> Note</p> <p>Make sure the o-ring is undamaged and properly fitted.</p>	<p>Screws: M5x12.</p>  <p>xx1200001013</p>

Continues on next page

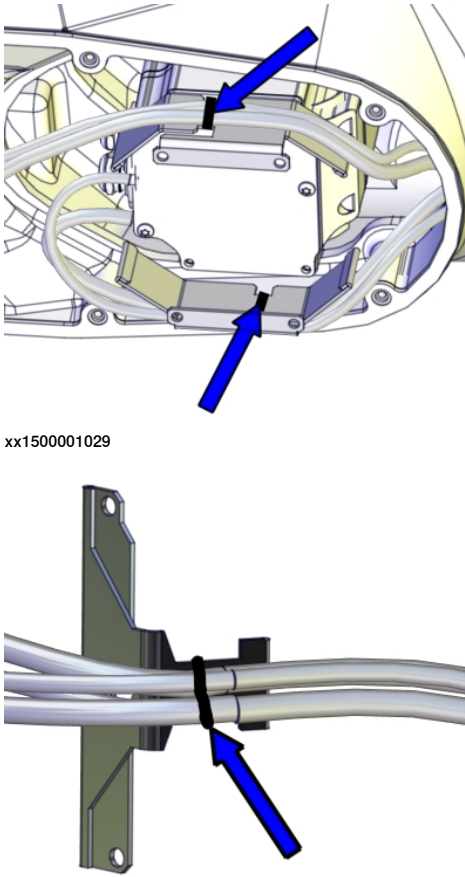
	Action	Note
7	<p>Secure the cable harness with cable straps to the heat protection plate.</p> <p> Note</p> <p>If replacing a type A motor with a type B motor, the heat protection plate must be replaced with plates suited for the type B motor. See Type A vs type B motors on page 805.</p>	<p>There are two versions of the heat protection plates.</p> <p>Choose figure depending on which plate is installed on the robot.</p>  <p>xx1500001029</p> <p>xx1300000489</p>

Continues on next page

4 Repair

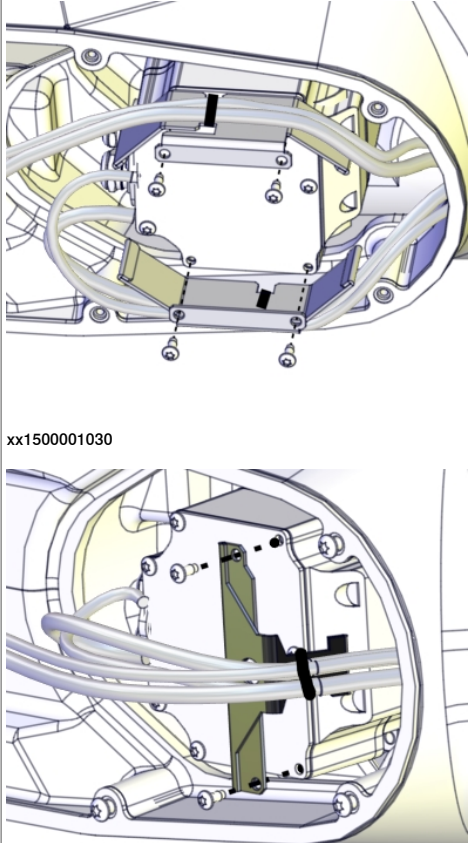

4.5.2 Replacing the wrist

Continued

	Action	Note
8	Fit the heat protection plate with the screws.	<p>Choose figure depending on which plate is installed on the robot. Screws: M5x12.</p>  <p>xx1500001030</p> <p>xx1300000490</p>

Continues on next page

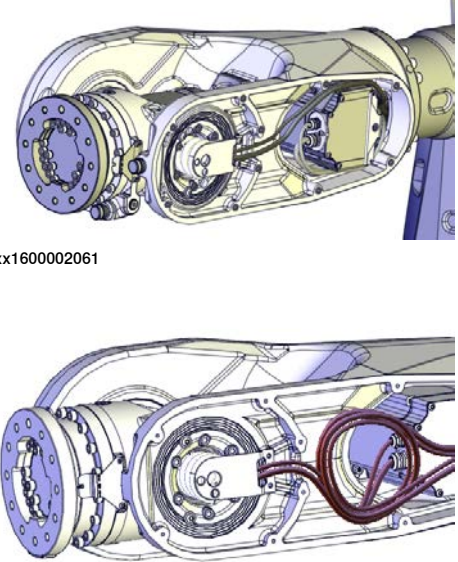
Connecting the axis-6 motor cables

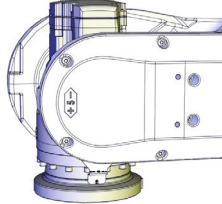
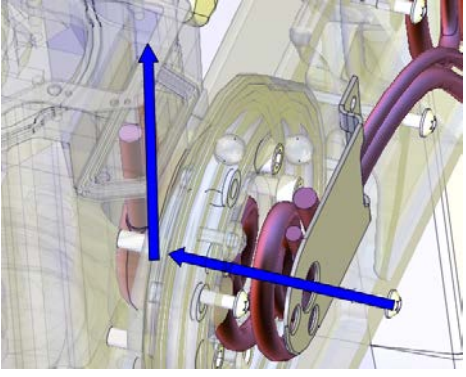

	Action	Note
1	<p>Make sure that the cable harness is placed in a way that it will not be damaged when the cover is fitted.</p>	 <p>xx1600002061</p> <p>xx130000596</p> <p>Cable layout in the wrist with Type A motors.</p>
2	<p> Note</p> <p>Axis 5 must be in position +90° (or as close as possible) for a correct installation of the cable harness in the wrist. If not, connect the 24 VDC power supply, release the brakes and move axis 5 manually to +90°.</p>	 <p>xx1200001081</p>
3	<p>Push the cable harness into the wrist recess and up into the axis-6 motor.</p>	 <p>xx130000667</p>

Continues on next page

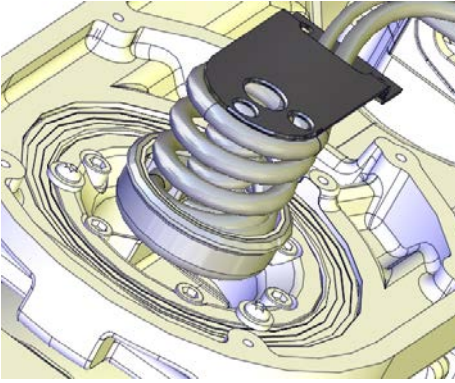

4 Repair

4.5.2 Replacing the wrist

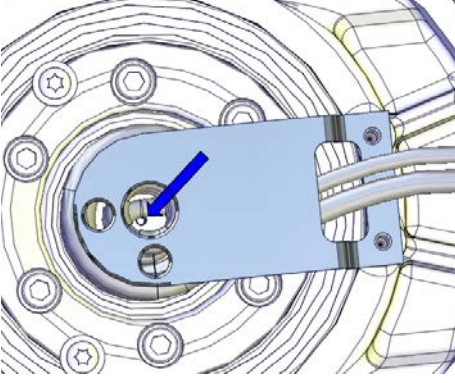
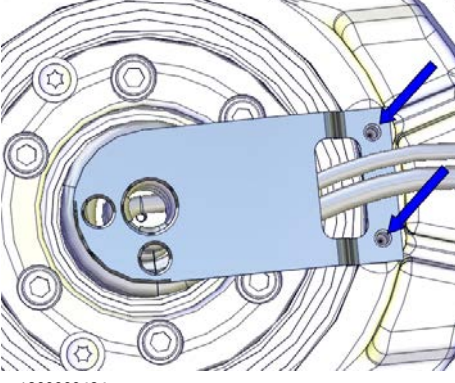
Continued

	Action	Note
4	Push the carrier carefully into position.	 xx1300001113
5	<p>Secure the carrier with the M4 screw.</p> <p> Note</p> <p>The screw is located at the bottom of the carrier.</p> <p> Tip</p> <p>The attachment screw securing the carrier may be difficult to fit. Make sure the carrier is level and completely pressed against the bottom.</p>	 xx1300000485
6	Secure the cable bracket with its attachment screws.	 xx1300000484

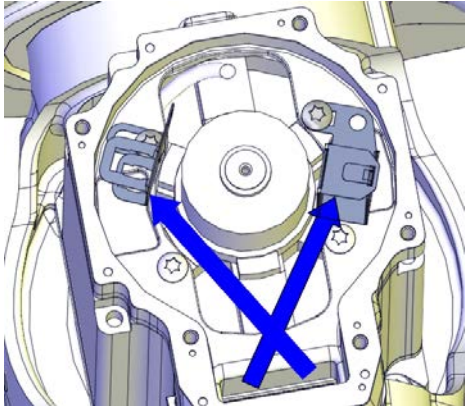
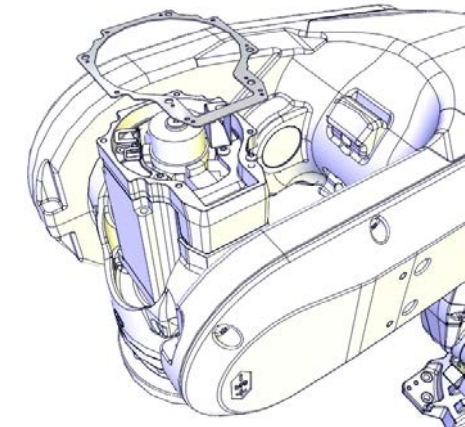
Continues on next page

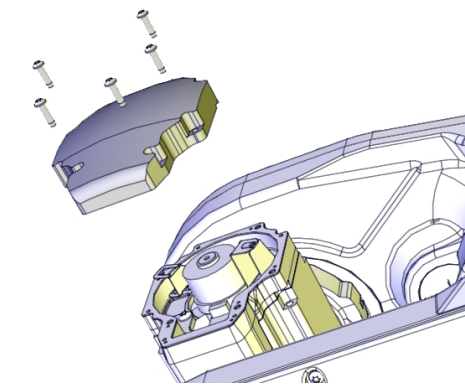
	Action	Note
7	<p>Reconnect the connectors to the axis-6 motor.</p> <p> Note</p> <p>Place the resolver cable under the motor cable.</p>	 <p>xx130000488</p>
8	<p>Make sure the gasket is undamaged. Replace if damaged.</p>	<p>Gasket, 3HAC033489-001/ 3HAC044252-001</p>  <p>xx1200001095</p>
9	<p> CAUTION</p> <p>When fitting the motor cover, make sure that none of the cables inside will be damaged.</p>	
10	<p>Refit the motor cover.</p>	 <p>xx1200001080</p>

Continues on next page

4 Repair



4.5.2 Replacing the wrist

Continued

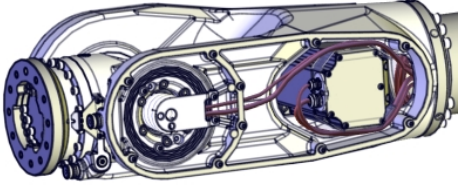
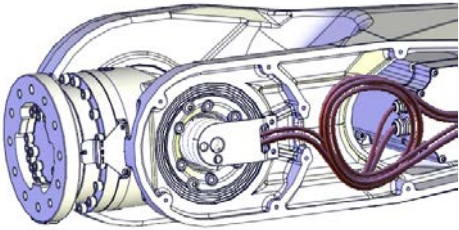
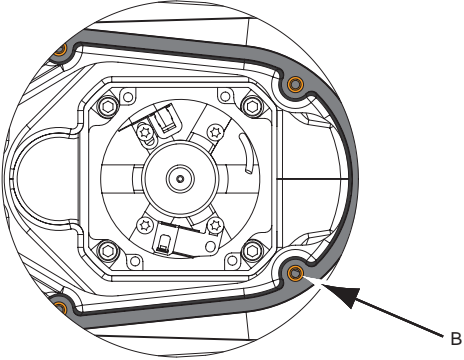
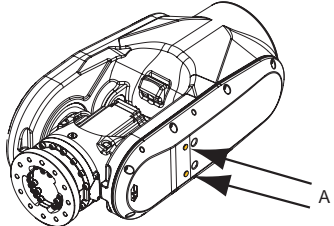
Concluding procedure

	Action	Note
1	<p>Make sure that the cable harness is placed in a way so it will not be damaged when the wrist cover is fitted.</p>	<p>There are two versions of the heat protection plates.</p> <p>Choose figure depending on which plate is installed on the robot.</p>  <p>xx1500001672</p>  <p>xx1300000596</p> <p>Cable layout in the wrist with Type A motors.</p>
2	<p>Foundry Plus: Inspect the gasket. Replace if damaged. Put washers in the holes of the gasket.</p>	  <p>xx1400000383</p> <p>A Protection plugs (2 on wrist cover and 2 on cover axis-5 gearbox) B Washers (10 pcs) in gasket holes</p>

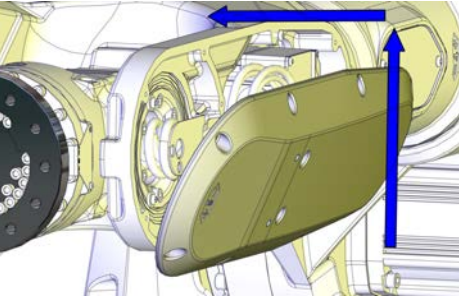
Continues on next page

	Action	Note
3	Refit the wrist cover. Use this method not to damage the cable harness: <ol style="list-style-type: none"> 1 Hold the cover tilted. See figure! 2 Catch any part of the cable harness hanging down. 3 Lift the cover, still held tilted. 4 Move the upper part of the cover into position. 5 Secure the cover with its attachment screws. 	 <p>xx1300000772</p> <p>Tightening torque: 10 Nm.</p>
4	<i>Foundry Plus:</i> Refit protection plugs.	
5	If used, refit the DressPack cable package on the wrist.	
6	Re-calibrate the robot.	Pendulum Calibration is described in <i>Operating manual - Calibration Pendulum</i> , enclosed with the calibration tools. Axis Calibration is described in Calibrating with Axis Calibration method on page 781 . General calibration information is included in section Calibration on page 767 .
7	 DANGER Make sure all safety requirements are met when performing the first test run.	

4 Repair

4.5.3 Replacing the turning disc

4.5.3 Replacing the turning disc

Location of the turning disc

The turning disc is located in the front of the wrist housing as shown in the figure.

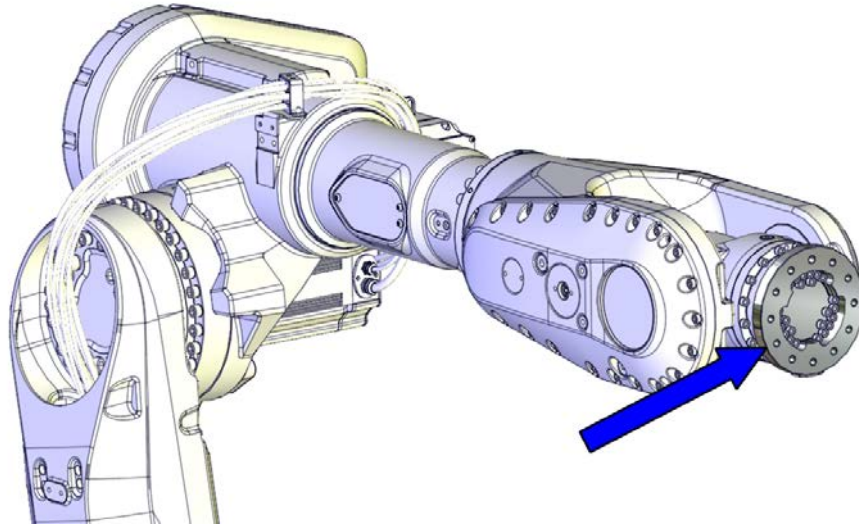

xx1300000491

Spare part

Spare part	Spare part number	Note
Turning disc	See <i>Product manual, spare parts - IRB 6700/IRB 6700Inv.</i> <i>Product manual, spare parts - IRB 6790</i>	

Consumables

Equipment, etc.	Article number	Note
Rust preventive	3HAC034903-001	Mercasol 3110 Waxcoat. Recommended drying time is 24h. Used on Foundry Plus.

Required tools and equipment

Equipment, etc.	Article number	Note
Standard toolkit	-	Content is defined in section Standard toolkit on page 814 .

Continues on next page

Removing the turning disc

Use these procedures to remove the turning disc.

Preparations before removing the turning disc

	Action	Note
1	Run the robot to a position most comfortable for the removal of the turning disc.	
2	 DANGER Turn off all: <ul style="list-style-type: none"> • electric power supply • hydraulic pressure supply • air pressure supply to the robot, before entering the safe-guarded space.	
3	Remove any equipment fitted to the turning disc.	

Removing the turning disc

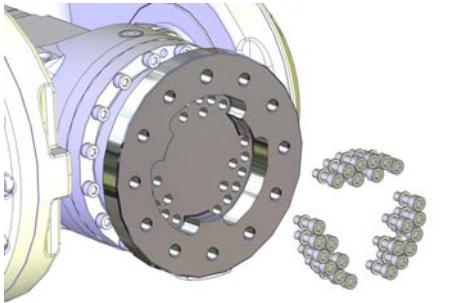
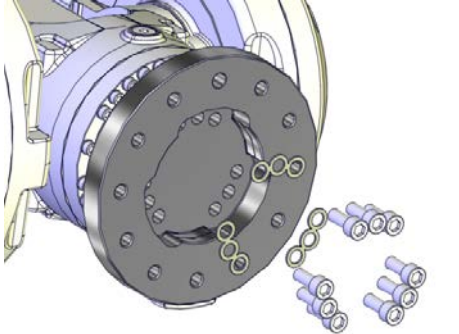
	Action	Note
1	- IRB 6700 - 235/2.65, IRB 6700 - 205/2.80, IRB 6700 - 175/3.05, IRB 6700 - 150/3.20 Remove the screws and washers, that secure the turning disc.	 <p data-bbox="970 1332 1082 1355">xx130000492</p>
2	- IRB 6700 - 200/2.60, IRB 6700 - 155/2.85 Remove the screws and washers, that secure the turning disc.	 <p data-bbox="970 1758 1082 1780">xx1300002302</p>

Continues on next page

4 Repair

4.5.3 Replacing the turning disc

Continued

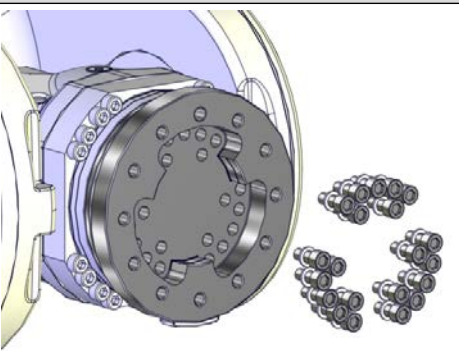
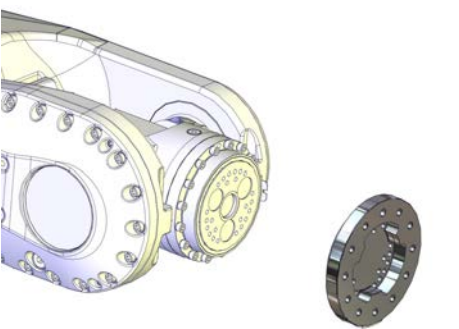
	Action	Note
3	- IRB 6700 - 300/2.70, IRB 6700 - 245/3.00 Remove the screws and washers, that secure the turning disc.	 <p>xx1400002195</p>
4	Remove the turning disc.	 <p>xx1300000493</p>

Continues on next page

Replacing the synchronization mark plate

The design of the turning disc spare part might require replacement of the axis-6 synchronization mark plate if the existing plate is not compatible with the new turning disc.

If ordering a new turning disc, the synchronization mark plate required is enclosed with the spare part. Check if the robot is already equipped with a compatible plate or if it needs to be replaced. The difference is shown in the figures.

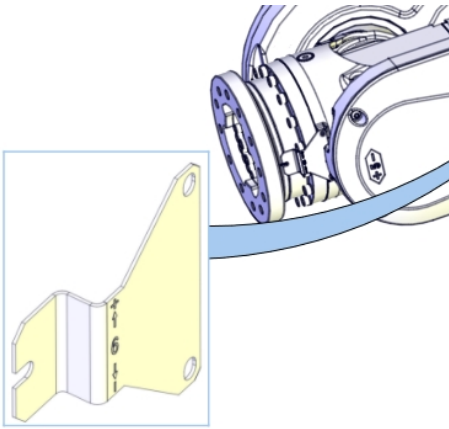
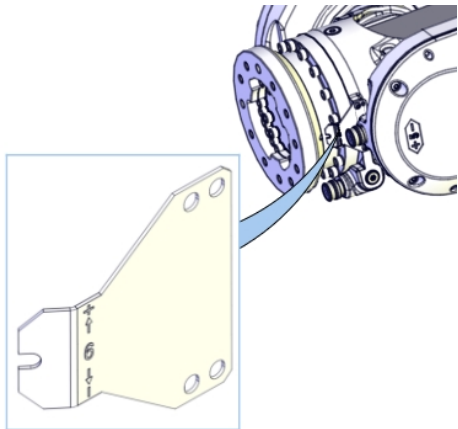
Incompatible axis-6 synchronization mark plate on robot	Compatible axis-6 synchronization mark plate on robot
	
<p>xx1500000873</p> <p>Incompatible synchronization mark plate is installed. Replace the plate.</p>	<p>xx1500000874</p> <p>Compatible synchronization mark plate is installed. No action required.</p>

Fitting the axis-6 synchronization mark plate

There are different attachment holes on the plate used for different robot variants. See table below.

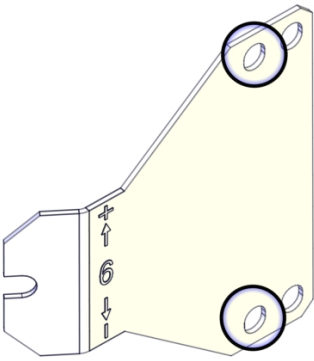
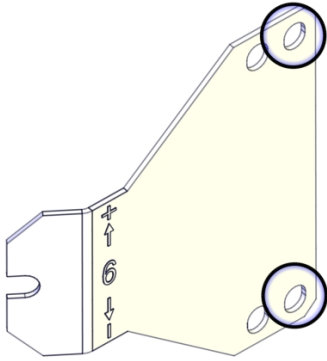
IRB 6700 - 235/2.65, IRB 6700 - 205/2.80, IRB 6700 - 175/3.05, IRB 6700 - 150/3.20, IRB 6700 - 200/2.60, IRB 6700 - 155/2.85	IRB 6700 - 300/2.70, IRB 6700 - 245/3.00
	
<p>xx1500000877</p> <p>Use the holes closest to the synchronization mark.</p>	<p>xx1500000878</p> <p>Use the holes at the back end of the synchronization plate.</p>

Continues on next page

4 Repair

4.5.3 Replacing the turning disc

Continued

Refitting the turning disc

Use this procedure to refit the turning disc.

Screw joint for refitting turning disc

Variant	Screw dimension	Number of screws	Number of washers	Tightening torque
IRB 6700 - 235/2.65	M8x25	24 pcs	24 pcs	35 Nm
IRB 6700 - 205/2.80	M8x25	24 pcs	24 pcs	35 Nm
IRB 6700 - 175/3.05	M8x25	24 pcs	24 pcs	35 Nm
IRB 6700 - 150/3.20	M8x25	24 pcs	24 pcs	35 Nm
IRB 6700 - 200/2.60	M10x25	9 pcs	3 pcs	70 Nm
IRB 6700 - 155/2.85	M10x25	9 pcs	3 pcs	70 Nm
IRB 6700 - 300/2.70	M10x25	21 pcs	21 pcs	70 Nm
IRB 6700 - 245/3.00	M10x25	21 pcs	21 pcs	70 Nm

Refitting the turning disc

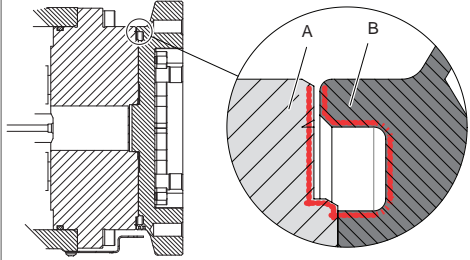
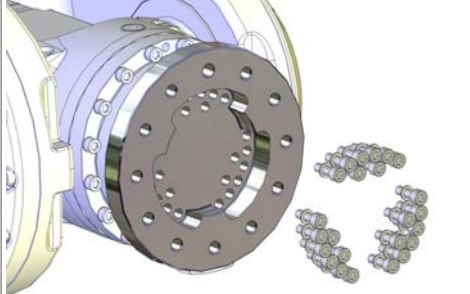
	Action	Note
1	If new turning disc spare part is installed: verify that the correct synchronization mark plate for axis-6 is installed on the wrist.	See Replacing the synchronization mark plate on page 355 .
2	Wipe clean the contact surfaces.	
3	Foundry Plus: Apply Mercasol on the surfaces on turning disc and axis-6 gearbox as shown in the figure.	 xx1400000385
4	IRB 6700 - 235/2.65, IRB 6700 - 205/2.80, IRB 6700 - 175/3.05, IRB 6700 - 150/3.20 Secure the turning disc with its attachment screws and washers.	Tightening torque: 35 Nm. Attachment screws: M8x25, Steel 12.9 Gleitmo 603 (24 pcs) Washers: Steel 8.4x13x1.5 (24 pcs)  xx1300000492

Continues on next page

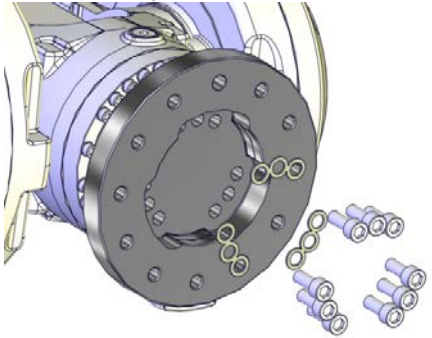
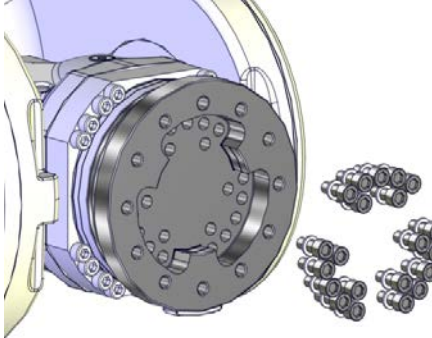
	Action	Note
5	IRB 6700 - 200/2.60, IRB 6700 - 155/2.85 Secure the turning disc with its attachment screws and washers.	Tightening torque: 70 Nm Attachment screws: M10x25, Steel 12.9 Gleitmo 603, (9 pcs) Washers: (3 pcs)  xx1300002302
6	IRB 6700 - 300/2.70, IRB 6700 - 245/3.00 Secure the turning disc with its attachment screws and washers.	Tightening torque: 70 Nm Attachment screws: M10x25, Steel 12.9 Gleitmo 603, (21 pcs) Washers: Steel 11x17x25 (21 pcs)  xx1400002195

Concluding procedure

	Action	Note
1	 DANGER Make sure all safety requirements are met when performing the first test run.	

4 Repair

4.5.4 Replacing the process turning disc

4.5.4 Replacing the process turning disc

Location of the process turning disc

The process turning disc is located in the front of the wrist housing as shown in the figure.

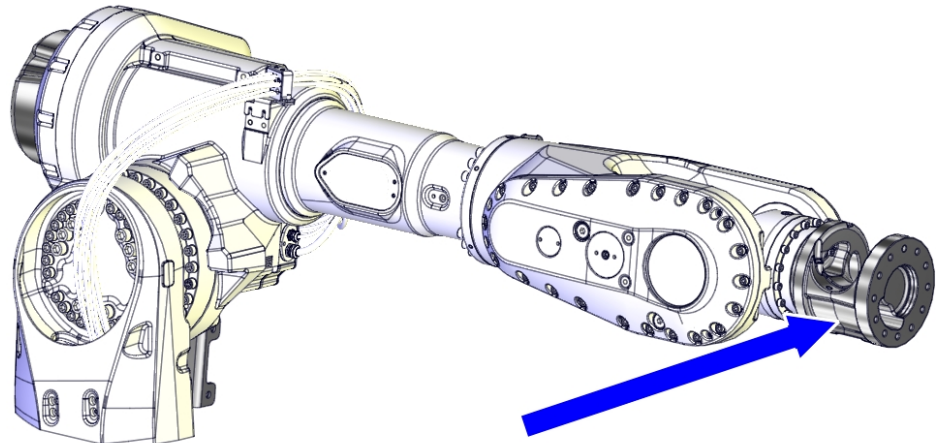

Required tools and equipment

Equipment, etc.	Article number	Note
Standard toolkit	-	Content is defined in section Standard toolkit on page 814 .

Consumables

Equipment, etc.	Article number	Note
Rust preventive	-	Mercasol, used on Foundry Plus

Removing the process turning disc

Use these procedures to remove the process turning disc.

Preparations before removing the process turning disc

	Action	Note
1	Run the robot to a position most comfortable for the removal of the process turning disc.	

Continues on next page

	Action	Note
2	 <p>DANGER</p> <p>Turn off all:</p> <ul style="list-style-type: none"> • electric power supply • hydraulic pressure supply • air pressure supply <p>to the robot, before entering the safe-guarded space.</p>	
3	Remove any equipment fitted to the process turning disc.	

Removing the process turning disc

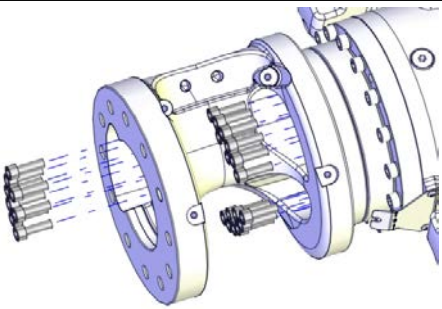
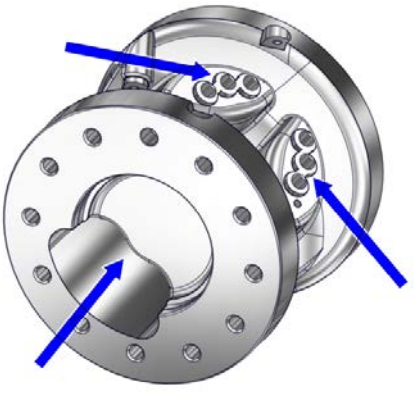
	Action	Note
1	<p><i>IRB 6700 - 235/2.65, - 205/2.80, - 175/3.05, - 150/3.20.</i></p> <p>Remove the 24 M8 screws and washers, that secure the process turning disc.</p>	
2	<p><i>IRB 6700 - 200/2.60, - 155/2.85.</i></p> <p>Remove the nine M10 screws and three washers, that secure the process turning disc.</p>	

Continues on next page

4 Repair

4.5.4 Replacing the process turning disc

Continued

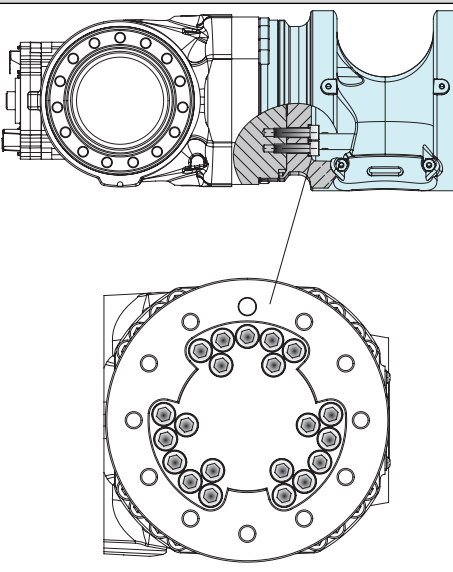
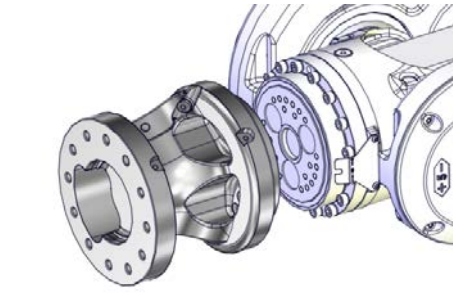
	Action	Note
3	<p><i>IRB 6700 -300/2.70, -245/3.00.</i></p> <p>Remove the 21 M10 screws and washers, that secure the process turning disc.</p>	
4	Remove the process turning disc.	

Replacing the synchronization mark plate

The images below shows a wrist with standard turning disc, but is also valid for the process turning disc.

The design of the turning disc spare part might require replacement of the axis-6 synchronization mark plate if the existing plate is not compatible with the new turning disc.

Continues on next page

4.5.4 Replacing the process turning disc
Continued

If ordering a new turning disc, the synchronization mark plate required is enclosed with the spare part. Check if the robot is already equipped with a compatible plate or if it needs to be replaced. The difference is shown in the figures.

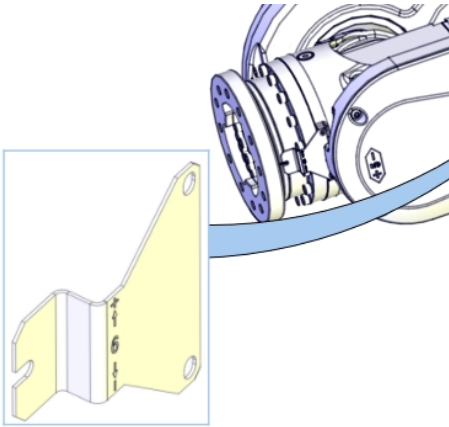
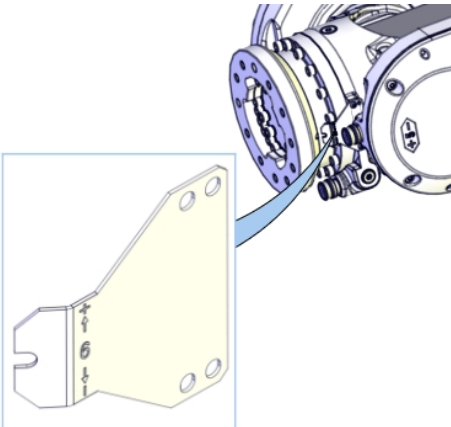
Incompatible axis-6 synchronization mark plate on robot	Compatible axis-6 synchronization mark plate on robot
 <p data-bbox="448 909 560 927">xx1500000873</p> <p data-bbox="448 947 938 1030">Incompatible synchronization mark plate is installed. Replace the plate.</p>	 <p data-bbox="949 909 1061 927">xx1500000874</p> <p data-bbox="949 947 1436 1030">Compatible synchronization mark plate is installed. No action required.</p>

Fitting the axis-6 synchronization mark plate

There are different attachment holes on the plate used for different robot variants. See table below.

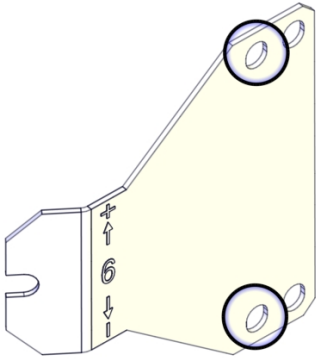
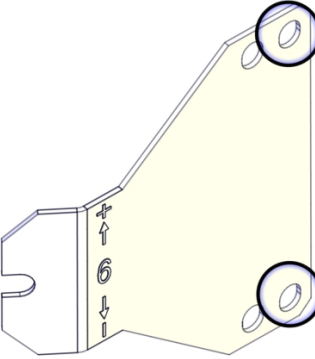
IRB 6700 - 235/2.65, IRB 6700 - 205/2.80, IRB 6700 - 175/3.05, IRB 6700 - 150/3.20, IRB 6700 - 200/2.60, IRB 6700 - 155/2.85	IRB 6700 - 300/2.70, IRB 6700 - 245/3.00
 <p data-bbox="448 1693 560 1711">xx1500000877</p>	 <p data-bbox="949 1693 1061 1711">xx1500000878</p>
<p data-bbox="448 1749 938 1805">Use the holes closest to the synchronization mark.</p>	<p data-bbox="949 1749 1436 1805">Use the holes at the back end of the synchronization plate.</p>

Continues on next page

4 Repair

4.5.4 Replacing the process turning disc

Continued

Refitting the process turning disc

Use this procedure to refit the process turning disc.

Screw joint for refitting process turning disc

Variant	Screw dimension	Number of screws	Number of washers	Tightening torque
IRB 6700 - 235/2.65	M8x25	24 pcs	24 pcs	35 Nm
IRB 6700 - 205/2.80	M8x25	24 pcs	24 pcs	35 Nm
IRB 6700 - 175/3.05	M8x25	24 pcs	24 pcs	35 Nm
IRB 6700 - 150/3.20	M8x25	24 pcs	24 pcs	35 Nm
IRB 6700 - 200/2.60	M10x25	9 pcs	3 pcs	70 Nm
IRB 6700 - 155/2.85	M10x25	9 pcs	3 pcs	70 Nm
IRB 6700 - 300/2.70	M10x25	21 pcs	21 pcs	70 Nm
IRB 6700 - 245/3.00	M10x25	21 pcs	21 pcs	70 Nm

Refitting the process turning disc

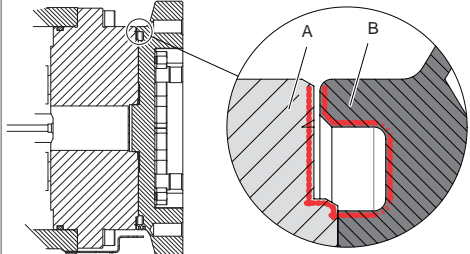
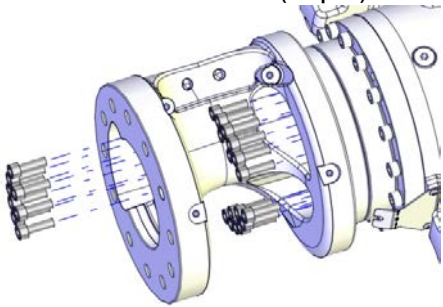
	Action	Note
1	If new turning disc spare part is installed: verify that the correct synchronization mark plate for axis-6 is installed on the wrist.	See Replacing the synchronization mark plate on page 360 .
2	Wipe clean the contacts surfaces.	
3	Foundry Plus: Apply Mercasol on the surfaces on the process turning disc and axis-6 gearbox as shown in the figure.	 <p>The figure show standard turning disc. Surfaces to apply Mercasol on are the same with process turning disc.</p>
4	IRB 6700 -235/2.65, -205/2.80, -175/3.05, -150/3.20. Secure the process turning disc with its attachment screws and washers.	<p>Tightening torque: 35 Nm. Attachment screws: M8x25, Steel 12.9 Gleitmo 603 (24 pcs) Washers: Steel 8.4x13x1.5 (24 pcs)</p> 

Continues on next page

4.5.4 Replacing the process turning disc

Continued

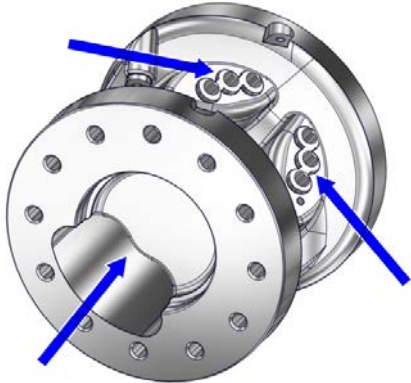
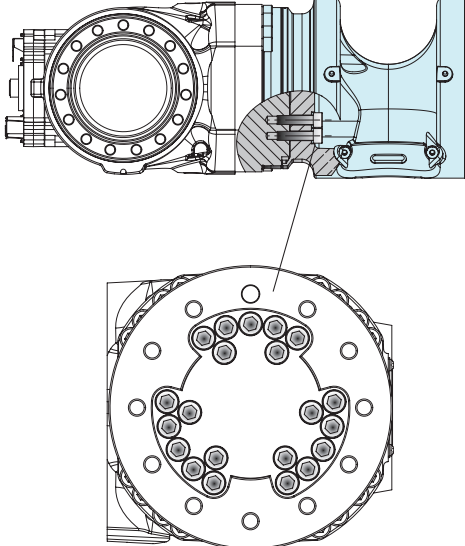
	Action	Note
5	<p><i>IRB 6700 -200/2.60, -155/2.85.</i> Secure the process turning disc with its attachment screws and washers.</p>	<p>Tightening torque: 70 Nm Attachment screws: M10x25, Steel 12.9 Gleitmo 603, (9 pcs) Washers: (3 pcs)</p> 
6	<p><i>IRB 6700 -300/2.70, -245/3.00.</i> Secure the process turning disc with its attachment screws and washers.</p>	<p>Tightening torque: 70 Nm Attachment screws: M10x25, Steel 12.9 Gleitmo 603, (21 pcs) Washers: Steel 11x17x25 (21 pcs)</p> 

Concluding procedure

	Action	Note
1	<p> DANGER Make sure all safety requirements are met when performing the first test run.</p>	

4 Repair

4.5.5 Replacing the lower arm

4.5.5 Replacing the lower arm

Location of the lower arm

The lower arm is located as shown in the figure.

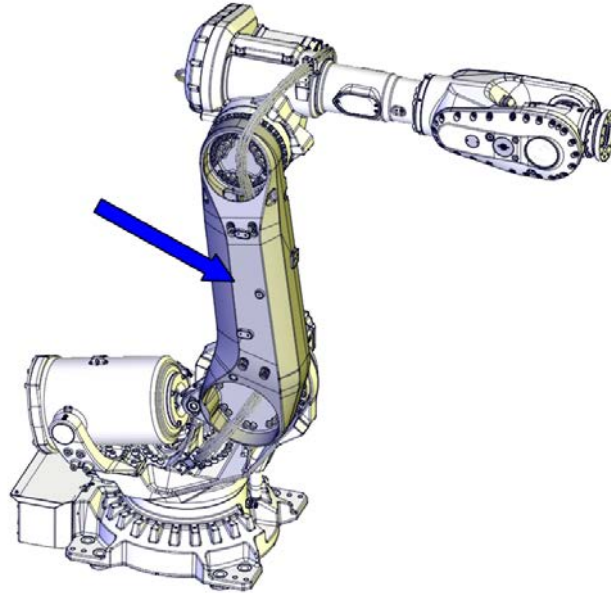

xx130000786

Summary of the replacement procedure

This is a brief summary of the replacement procedure, containing the major actions to be performed.

- 1 Unload the balancing device.
- 2 Remove the shaft in the balancing device front link ear
- 3 Remove the cabling from the upper and lower arm.
- 4 Remove the upper arm.
- 5 Replace the lower arm.

Spare part

Spare part	Spare part number	Note
Lower arm	See <i>Product manual, spare parts - IRB 6700/IRB 6700Inv.</i> <i>Product manual, spare parts - IRB 6790</i>	

Continues on next page

Consumables

Equipment	Article number	Note
Grease	3HAA1001-294	Tribol GR 100-0 PD, 50 ml For lubrication of the front bearing of the balancing device.
Grease	3HAC042536-001	Shell Gadus S2 Used to lubricate o-rings.
O-ring	3HAB3772-111 (circular profile) / 3HAC054692-002 (hexagon profile)	D=169.5x3 Used on axis-3 motor cover.
	3HAB3772-110 (circular profile) / 3HAC054692-001 (hexagon profile)	D=119x3 Used on axis-4 motor cover.
	3HAB3772-110 (circular profile) / 3HAC054692-001 (hexagon profile)	D=119x3 Used on axis-5 motor cover.
Gasket	3HAC033489-001/ 3HAC044252-001	Used on axis-6 motor cover.
Rust preventive	3HAC034903-001	Mercasol 3110 Waxcoat. Recommended drying time is 24h. Used on Foundry Plus.

Required tools and equipment

Equipment	Article number	Note
Distance tool	3HAC030662-001	Only used to keep the balancing device in a locked position, after the balancing device springs has been unloaded with the help of the robot itself.  DANGER <i>Never</i> use this tool to unload or restore a balancing device!
Lifting shackle	-	SA-10-8-NA1
Lifting accessory (chain)	3HAC15556-1	Lifting instruction 3HAC15880-2 enclosed.
Dismantle and mounting tool	3HAC028920-001	Used for removing and fitting shaft and bearings. User instructions are enclosed with the tool.
Hydraulic pump 80 MPa	3HAC13086-1	To be used with the press and puller tools. See technical specifications in the user instructions for the press equipment.
Hydraulic cylinder	3HAC11731-1	To be used with the press and puller tools. See technical specifications in the user instructions for the press equipment.

Continues on next page

4 Repair

4.5.5 Replacing the lower arm

Continued

Equipment	Article number	Note
Lifting eye	3HAC16131-1	M12
Lifting eye	3HAC16131-1	M12
Lifting accessory (chain)	3HAC15556-1	Lifting instruction 3HAC15880-2 enclosed.
Guide pin, M12x150	3HAC13056-2	Always use guide pins in pairs.
Guide pin, M12x200	3HAC13056-3	Always use guide pins in pairs.
Pallet		Used for putting down removed parts from robot.
Guide pin, M16x150	3HAC13120-2	Always use guide pins in pairs.
Rotation tool	3HAB7887-1	Used to rotate the motor pinion.
24 VDC power supply	-	Used to release the motor brakes.
Anvil	3HAC047273-001	Included in the tool kit Dismantle and mounting tool (3HAC028920-001).
Calibration Pendulum toolkit	3HAC15716-1	Required if Calibration Pendulum is the valid calibration method for the robot.
Calibration tool box, Axis Calibration	3HAC055412-001	Delivered as a set of calibration tools. Required if Axis Calibration is the valid calibration method for the robot.
Standard toolkit	-	Content is defined in section Standard toolkit on page 814 .

Deciding calibration routine

Decide which calibration routine to be used, based on the information in the table. Depending on which routine is chosen, action might be required prior to beginning the repair work of the robot, see the table.

	Action	Note
1	<p>Decide which calibration routine to use for calibrating the robot.</p> <ul style="list-style-type: none"> Reference calibration. External cable packages (DressPack) and tools can stay fitted on the robot. Fine calibration. All external cable packages (DressPack) and tools must be removed from the robot. 	
	<p>If the robot is to be calibrated with reference calibration:</p> <p>Find previous reference values for the axis or create new reference values. These values are to be used after the repair procedure is completed, for calibration of the robot.</p> <p>If no previous reference values exist, and no new reference values can be created, then reference calibration is not possible.</p>	<p>Follow the instructions given in the reference calibration routine on the FlexPendant to create reference values.</p> <p>Creating new values requires possibility to move the robot.</p> <p>Read more about reference calibration for Axis Calibration in Reference calibration routine on page 782.</p> <p>Read more about reference calibration for Pendulum Calibration in <i>Operating manual - Calibration Pendulum</i>.</p>

Continues on next page

Action	Note
<p>If the robot is to be calibrated with fine calibration: Remove all external cable packages (DressPack) and tools from the robot.</p>	

Removing the lower arm

Use these procedures to remove the lower arm.

Preparations before removing the lower arm

Action	Note
1 Decide which calibration routine to use, and take actions accordingly prior to beginning the repair procedure.	
<p> DANGER</p> <p>Turn off all:</p> <ul style="list-style-type: none"> • electric power supply • hydraulic pressure supply • air pressure supply <p>to the robot, before entering the safe-guarded space.</p>	
3 Remove all equipment fitted to upper and lower arms.	

Position of the robot in the continued process

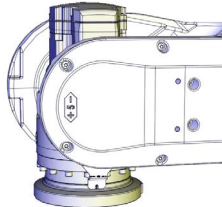
Action	Note
1 Jog the robot to: <ul style="list-style-type: none"> • Axis 1: 0° • Axis 2: 0° • Axis 3: 0° • Axis 4: 0° • Axis 5: +90° • Axis 6: 0° 	
2 Connect the 24 VDC power supply, release the brakes and move the axis 5 manually into +90°. <p>Connect to R2.MP5-connector:</p> <ul style="list-style-type: none"> • + = pin 2 • - = pin 5 	<p>24 VDC power supply</p>  <p>xx1200001081</p>

Continues on next page

4 Repair



4.5.5 Replacing the lower arm

Continued





	Action	Note
3	 DANGER Turn off all: <ul style="list-style-type: none">• electric power supply• hydraulic pressure supply• air pressure supply to the robot, before entering the safe-guarded space.	

Unloading the balancing device springs with the robot and locking position with the Distance tool

Use this procedure to unload the balancing device with the help of the robot, and lock the balancing device springs in a compressed position, using the Distance tool (3HAC030662-001).

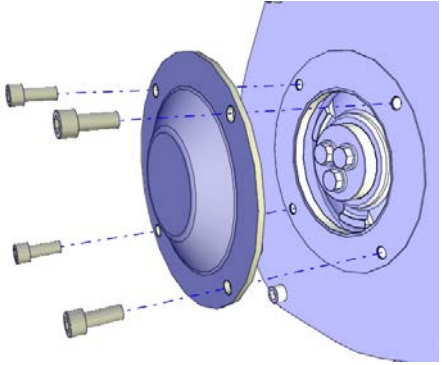
	Action	Note
1	 DANGER Do not use the Distance tool (3HAC030662-001) to unload or restore the pressure of the balancing device springs! This tool is only used to lock the spring unit in a compressed position, after axis-2 has been jogged to -30° or $+30^\circ$. Fitting and removal of the tool shall only be done with axis-2 in this position! To unload or restore a new balancing device or if the spring unit of the balancing device cannot be compressed by jogging the robot, only use the Hydraulic press equipment, balancing device (3HAC074411-001).	
2	Jog axis-2 to: <ul style="list-style-type: none">• -30° or $+30^\circ$	This is done in order to compress the balancing device springs inside the balancing device before fitting the Distance tool.
3	 DANGER Turn off all: <ul style="list-style-type: none">• electric power supply• hydraulic pressure supply• air pressure supply to the robot, before entering the robot working area.	

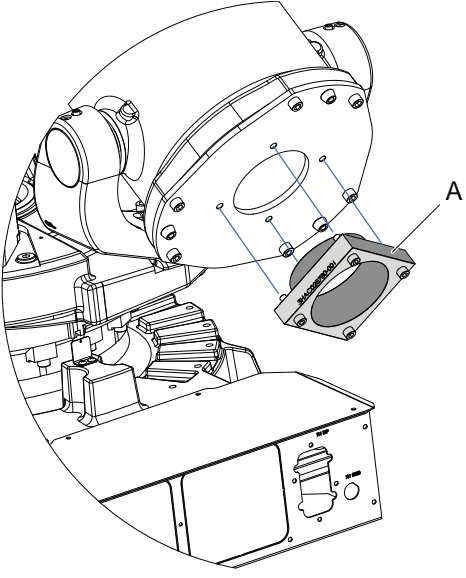
Continues on next page

	Action	Note
4	<p>Remove the cover plate on the back of the balancing device.</p> <p> DANGER</p> <p>DO NOT remove any other screws than the rear cover attachment screws.</p>	 <p>xx1300000554</p>
5	<p>Fit the Distance tool on the back of the balancing device using the four screws.</p> <p> DANGER</p> <p>Use caution when tightening the screws. The threads in the cover can be damaged if more tightening torque than 45 Nm is used, risking that the Distance tool is not properly fitted.</p>	<p>Tightening torque: 45 Nm Attachment screws: M10 quality 12.9 (4 pcs)</p>  <p>xx0800000480</p> <p>A Distance tool: 3HAC030662-001</p>
6	<p>Turn the power on temporary.</p>	
7	<p>Jog axis-2 to the calibration position. The balancing device is now unloaded.</p>	<p>This is done to compress the balancing device springs, making it possible to remove the front shaft of the balancing device.</p>
8	<p>Let the Distance tool stay fitted during the continued procedure.</p>	
9	<p> DANGER</p> <p>Turn off all:</p> <ul style="list-style-type: none"> • electric power supply • hydraulic pressure supply • air pressure supply <p>to the robot, before entering the robot working area.</p>	



Continues on next page

4 Repair

4.5.5 Replacing the lower arm

Continued

Preparations before removing the shaft in the link ear

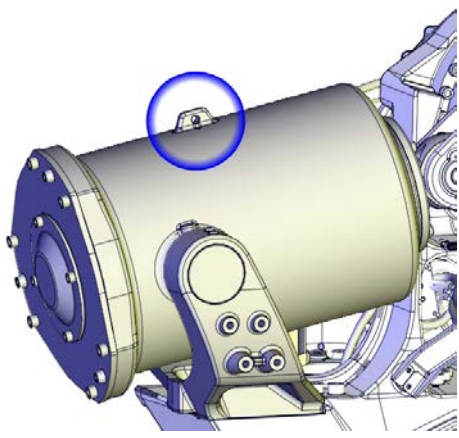
	Action	Note
1	Jog axis-2 to the calibration position (if not already in this position).	
2	 DANGER Turn off all: <ul style="list-style-type: none"> • electric power supply • hydraulic pressure supply • air pressure supply to the robot, before entering the safe-guarded space.	
3	Remove any equipment, if fitted, on or close to the balancing device.	
4	 CAUTION The weight of the balancing device (excluding cradle) is 140 kg (IRB 6700 -235/2.65, -205/2.80, -175/3.05, -150/3.20, -200/2.60, -155/2.85) 185 kg (IRB 6700 -300/2.70, -245/3.00) All lifting accessories used must be sized accordingly.	
5	Fit a lifting shackle to the balancing device.	Lifting shackle: SA-10-8-NA1  <small>xx1300000661</small>
6	Fit the lifting accessory (chain) to the shackle and raise to unload the weight.	Lifting accessory (chain): 3HAC15556-1

Continues on next page

Removing the shaft in the front (link ear)

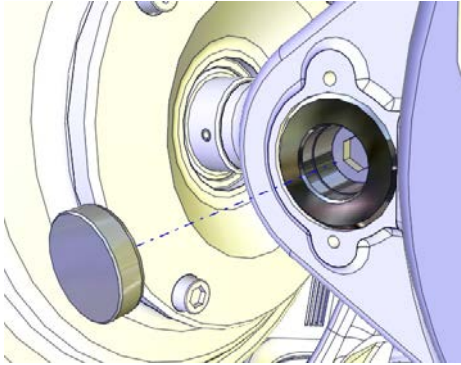
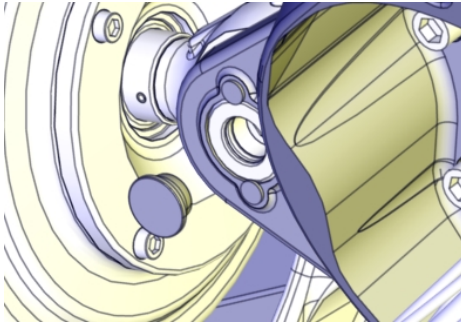
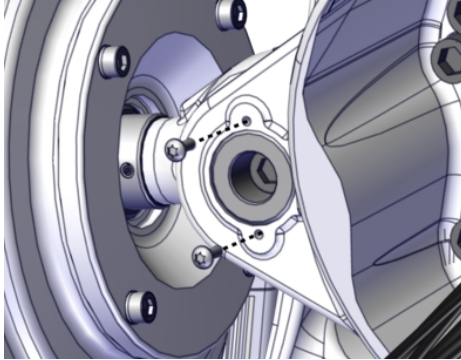

	Action	Note
1	Remove the protection plug or VK cover at the link ear (depends on shaft version).	<p>It is possible to drive a screwdriver (or similar) through the VK cover, as close as possible to the center of the VK cover and pull it out.</p>  <p>xx1200001278</p>  <p>xx1900002311</p>
2	Remove the two screws.	 <p>xx1900002146</p>

Continues on next page

4 Repair

4.5.5 Replacing the lower arm

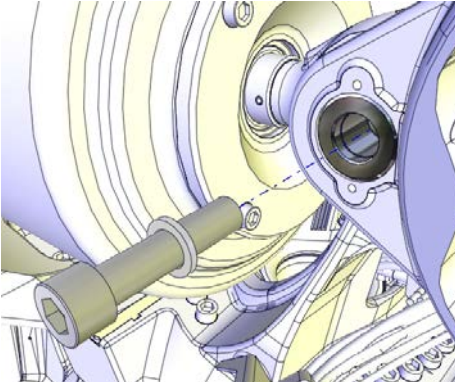
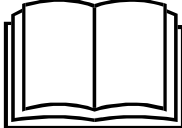
Continued

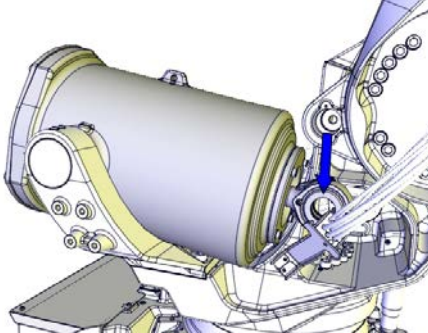
	Action	Note
3	Unscrew the attachment screw and washer.	 xx1200001279 <ul style="list-style-type: none">• M16x70 quality steel 8.8-A3F
4	Pull the shaft out using the dismantle and mounting tool, according to user instructions enclosed with the equipment.  xx0900000813 Go to the user instructions enclosed with the press tool.  DANGER Handling the tool incorrectly will cause serious injury. Read and follow enclosed user instructions for the tool.	Dismantle and mounting tool: 3HAC028920-001 User instructions are enclosed with the tool.
5	Put down the balancing device and let it rest on the frame.	 xx1200001281

Continues on next page

Retrieving access to the wrist cabling

Use this procedure to remove the wrist cover to retrieve access to the axis-5 and axis-6 motor cables.

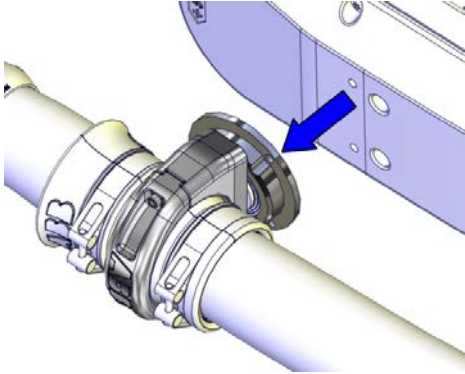
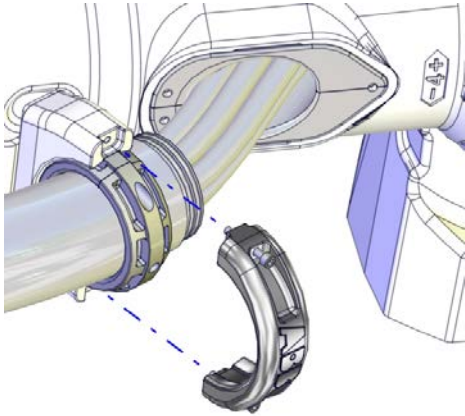
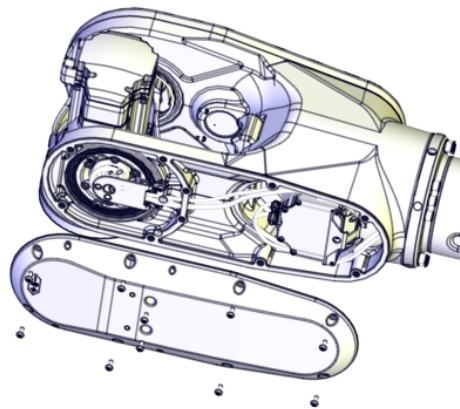
Action	Note
<p>1</p>  <p>DANGER</p> <p>Make sure that all supplies for electrical power, hydraulic pressure, and air pressure are turned off.</p>	
<p>2</p> <p>If DressPack is installed:</p> <ul style="list-style-type: none"> Remove the bracket with the complete ball joint housing still fitted, as shown in the figure. <p>This is done to be able to reach the two hidden screws that secure the wrist cover.</p>	 <p>xx140000355</p>
<p>3</p> <p>If used, open the ball joint housing on the arm tube and remove the DressPack cable package.</p>	 <p>xx140000206</p>
<p>4</p> <p>Remove the wrist cover.</p>	 <p>xx1300002247</p>

Continues on next page



4 Repair

4.5.5 Replacing the lower arm

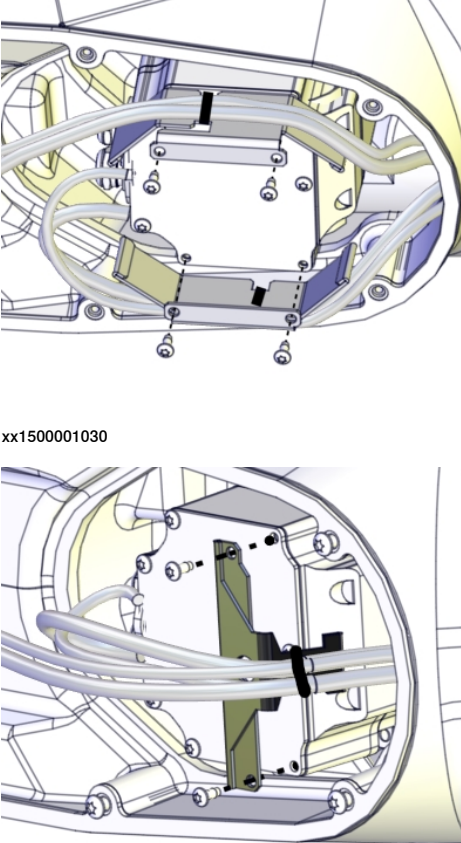
Continued

	Action	Note
5	<p>Remove the heat protection plate/plates from the motor with the cabling still attached to the plate.</p> <p>Remove the heat protection plates from the motor with the cabling still attached to the plate.</p>	<p>There are two versions of the heat protection plates.</p> <p>Choose figure depending on which plate is installed on the robot.</p> 

Continues on next page

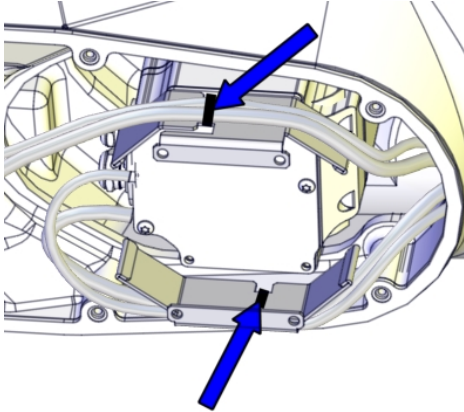
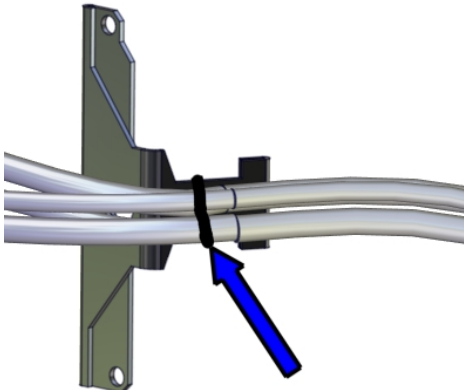
	Action	Note
6	<p>Cut the cable ties that hold the cable harness to the plate.</p> <p> Note</p> <p>Keep the heat protection plate until refitting.</p> <p> Tip</p> <p>If removing the plate only for replacing the motor, the cabling does not need to be loosened from the plate.</p>	<p>Choose figure depending on which plate is installed on the robot.</p>  <p>xx1500001029</p>  <p>xx1300000489</p>

Removing cable brackets

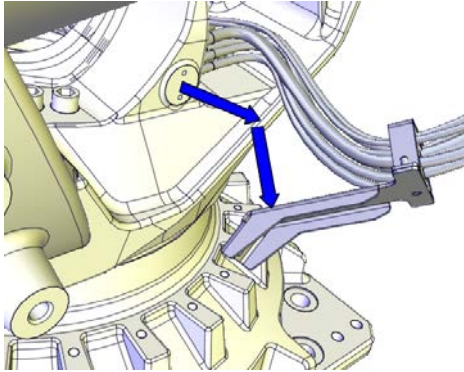
	Action	Note
1	<p>Unscrew the screws that hold the bracket and let it hang free.</p>	 <p>xx1200001184</p>

Continues on next page

4 Repair

4.5.5 Replacing the lower arm

Continued

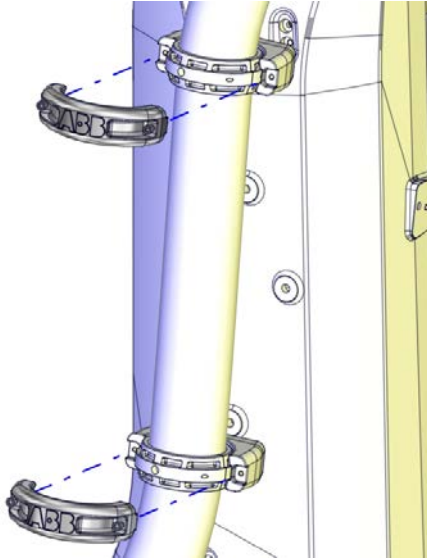
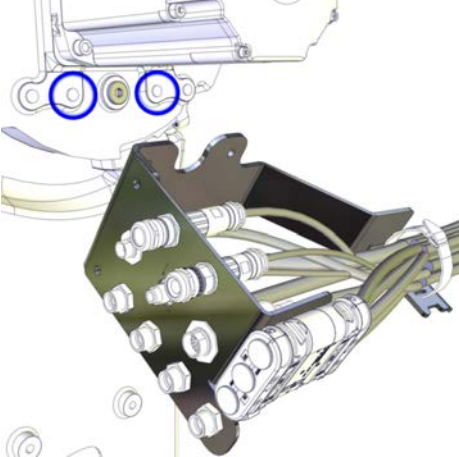
	Action	Note
2	If used, open the ball joint housings on the lower arm and remove the DressPack.	 <p>xx140000195</p>
3	If used, unscrew the screws that hold the connection plate and let the DressPack hang free.	 <p>xx1200001332</p>

Disconnecting the axis-3 and axis-4 motor cables

	Action	Note
1	 <p>DANGER</p> <p>Make sure that all supplies for electrical power, hydraulic pressure, and air pressure are turned off.</p>	

Continues on next page

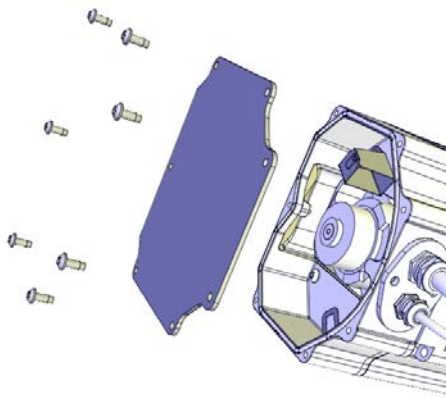
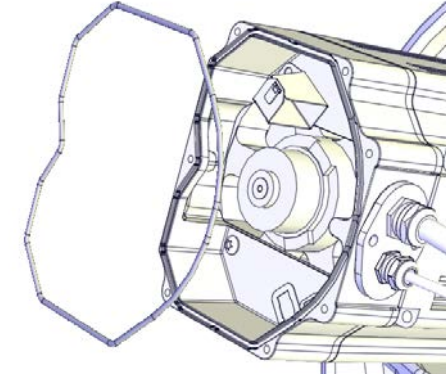
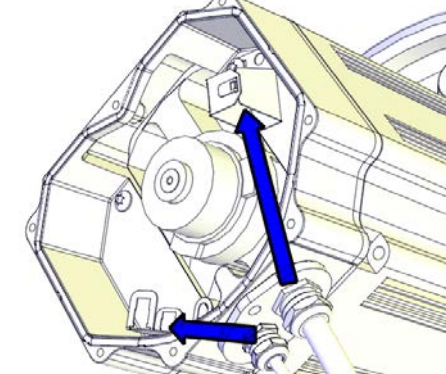
	Action	Note
2	Unscrew the attachment screws and washers and remove the motor cover.	 <p>xx1200001135</p>
3	Make sure the o-ring is present.	 <p>xx1200001070</p>
4	Disconnect the motor cables.	 <p>xx1200001066</p>

Continues on next page

4 Repair

4.5.5 Replacing the lower arm

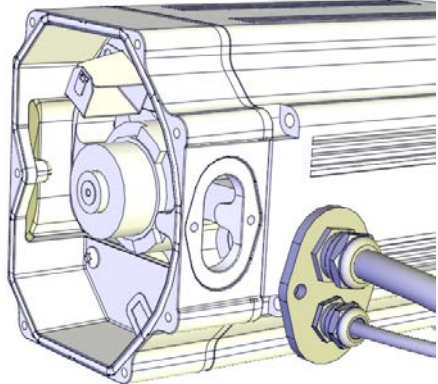

Continued

	Action	Note
5	<p>Remove the cable gland cover. Make sure the gasket is not damaged.</p> <p> Tip</p> <p>Make a note in which direction the cable gland hole is facing, if the motor will be removed too. The motor shall be refitted in the same position.</p>	 <p>xx1200001067</p>
6	Use caution and pull out the motor cables.	

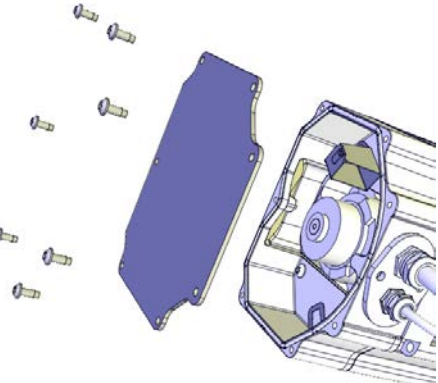
Disconnecting the axis-5 motor cables

	Action	Note
1	<p> DANGER</p> <p>Make sure that all supplies for electrical power, hydraulic pressure, and air pressure are turned off.</p>	
2	Unscrew the attachment screws and washers and remove the motor cover.	 <p>xx1200001135</p>

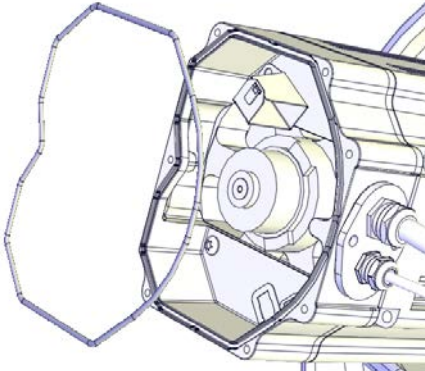
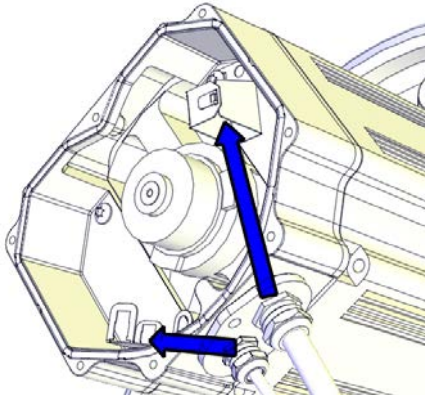
Continues on next page

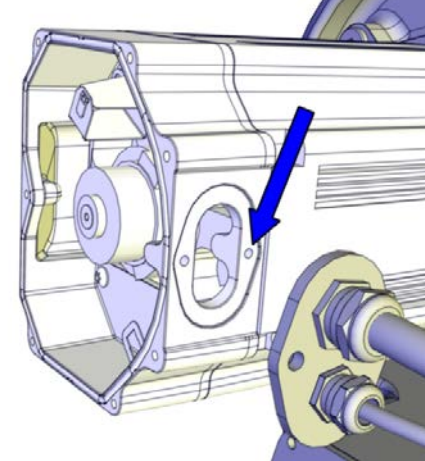
	Action	Note
3	Make sure the o-ring is present.	 <p>xx1200001070</p>
4	Disconnect the motor cables.	 <p>xx1200001066</p>
5	<p>Remove the cable gland cover by performing the following steps:</p> <ol style="list-style-type: none"> 1 Open the inner screw a little (the one the arrow is pointing at). No need to remove this screw from the motor. 2 Remove the outer screw. 3 Slide the cable gland cover away from the inner screw. Make sure the gasket is not damaged. <p> Tip</p> <p>Make a note in which direction the cable exit hole is facing, if the motor will be removed too. The motor shall be refitted in the same position.</p>	 <p>xx1300000656</p>
6	Use caution and pull out the motor cables.	

Continues on next page

4 Repair

4.5.5 Replacing the lower arm

Continued

Disconnecting the axis-6 motor cables

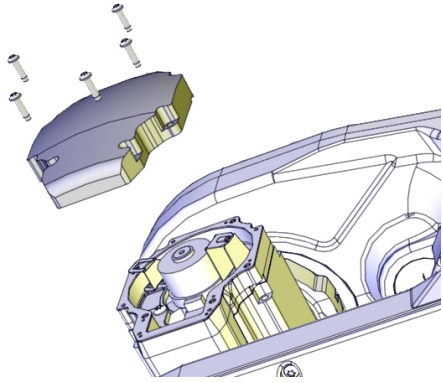
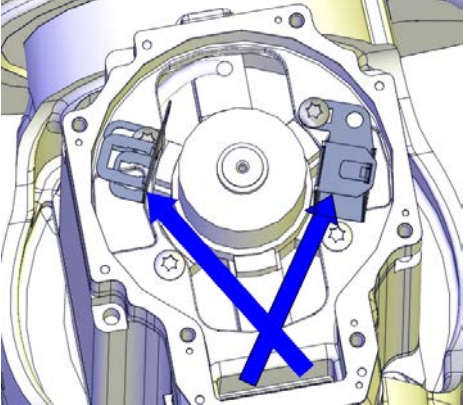
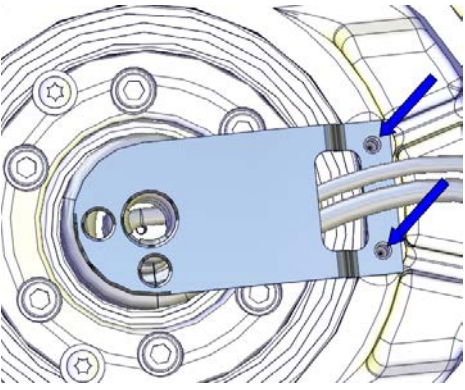
	Action	Note
1	 DANGER Make sure that all supplies for electrical power, hydraulic pressure, and air pressure are turned off.	
2	Unscrew the attachment screws and remove the motor cover.	 xx1200001080
3	Disconnect the motor cables.	 xx1300000488
4	Unscrew the attachment screws that hold the cable bracket.	 xx1300000484

Continues on next page

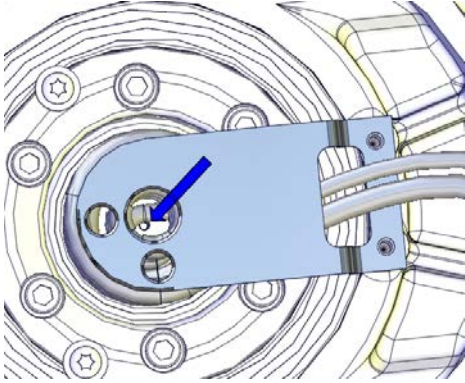
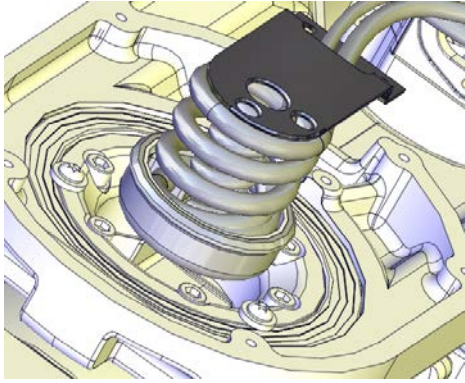
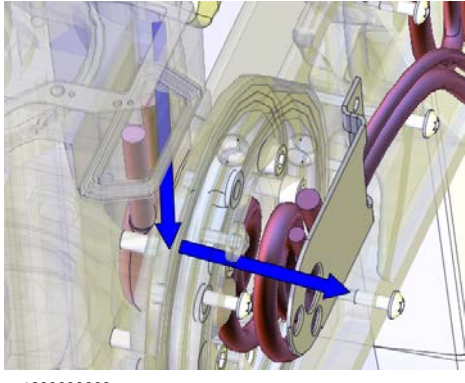
	Action	Note
5	<p>Unscrew the M4 screw that holds the carrier.</p> <p> Note</p> <p>The screw is located at the bottom of the carrier.</p>	 <p>xx130000485</p>
6	<p>Pull out the carrier from its position.</p>	 <p>xx1300001113</p>
7	<p>Pull out the axis-6 motor cables by holding the cables with one hand at the motor and the other at the carrier.</p>	 <p>xx130000666</p>

Continues on next page

4 Repair



4.5.5 Replacing the lower arm

Continued

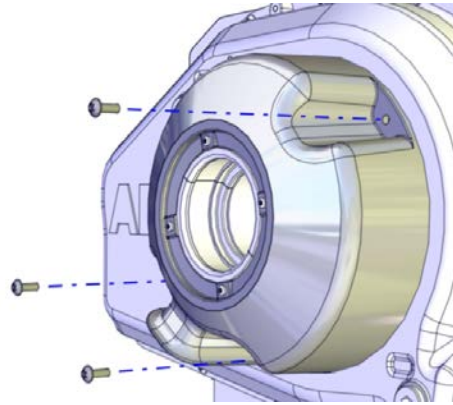
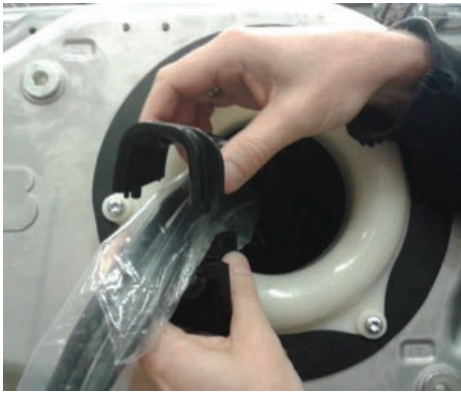
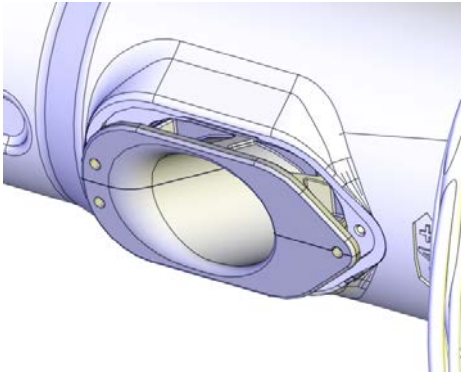
Removing the cable harness - wrist and upper arm

	Action	Note
1	<p>Remove the cover.</p> <p> Note</p> <p><i>Foundry Plus:</i> Use caution not to damage the gasket, not to loose the washers on the cover sealing or not to loose the inserts fitted on the cover.</p>	 <p>xx120000045</p>
2	<p>If the cabling is to be replaced by a new cable harness, remove the cover insert to use it on the new cabling.</p>	 <p>xx1700001803</p>
3	<p>If used, loosen the insert.</p>	 <p>xx1700000690</p>

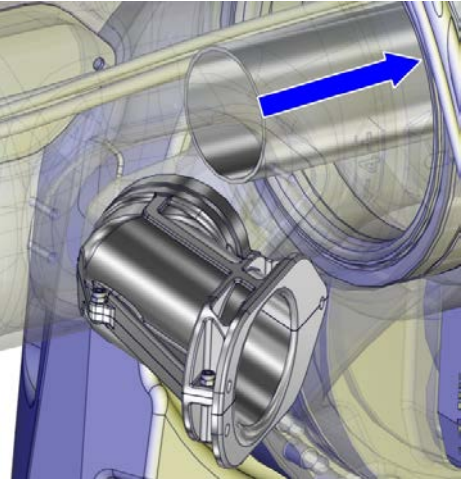
Continues on next page

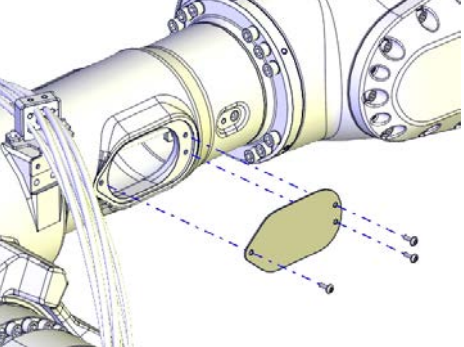
	Action	Note
4	<p>If used, push the DressPack tube a little backwards.</p>	 <p>xx140000720</p>
5	<p> Tip</p> <p>Use tape and tie the axis-5 and axis-6 connectors and carrier into a bundle (if not already done). This is done to facilitate the removal and to avoid damaging the parts. This will also make it easier to run the cable harness through the inside of the upper arm.</p>	 <p>xx130000668</p>
6	<p>Remove the side cover on the arm tube.</p>	 <p>xx130000557</p>

Continues on next page

4 Repair

4.5.5 Replacing the lower arm

Continued

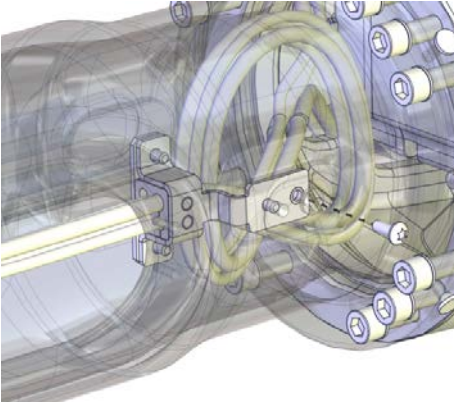
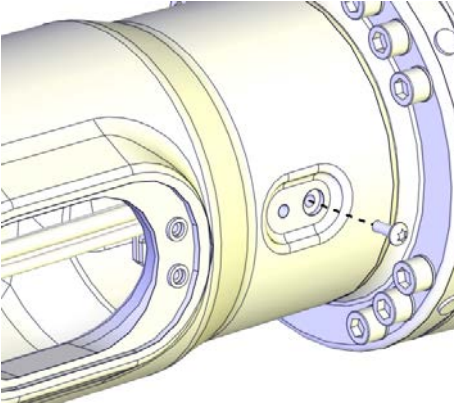
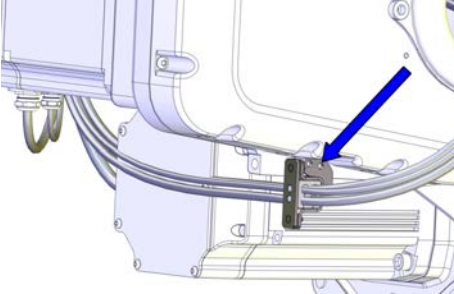
	Action	Note
7	<p>Unscrew the attachment screw that secures the axis-4 metal clamp inside the arm tube.</p> <p> Note</p> <p>The screw is reached from outside the upper arm.</p>	 <p>xx170000340</p>  <p>xx170000339</p>
8	Remove the arm house metal clamp.	 <p>xx130000543</p>

Continues on next page

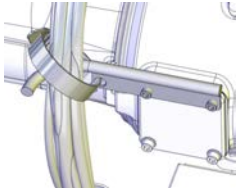
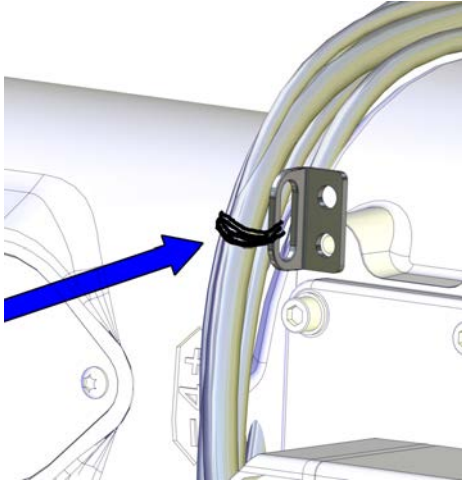
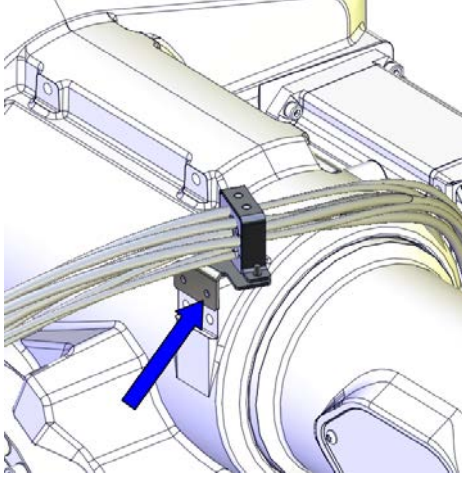

	Action	Note
9	<p>Cut the cable tie at the cable fixing bracket.</p> <p> Note</p> <p>If DressPack is fitted, the cable fixing bracket is replaced by the cable guide.</p>  <p>xx1300001973</p> <p>Cable guide.</p>	 <p>xx1300000544</p> <p>Cable fixing bracket.</p>
10	<p>Remove the metal clamp on top of the arm house.</p>	 <p>xx1300000541</p>

Continues on next page

4 Repair

4.5.5 Replacing the lower arm

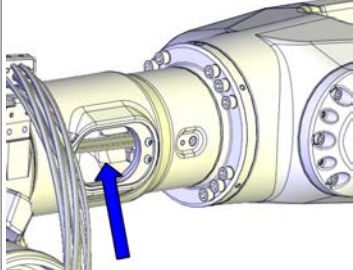
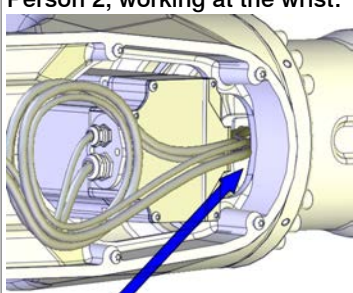

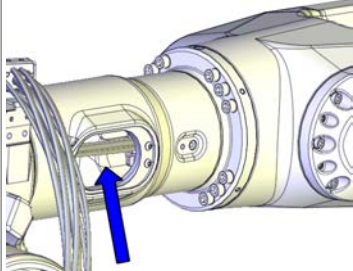
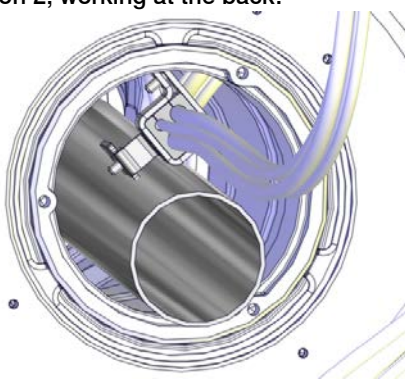
Continued

	Action	Note
11	<p>Remove the cable harness out from the wrist.</p> <p> Tip</p> <p>This step is best performed by two persons working together:</p> <ul style="list-style-type: none">• Person 1: Put one hand inside the side hole and take a hold of the cable harness.• Person 2: Take a hold on the cable harness inside the wrist.• Together: Move the cable harness past the axis-5 motor and into the arm tube.	<p>Person 1, working at the side hole:</p>  <p>xx130000745</p> <p>Person 2, working at the wrist:</p>  <p>xx130000746</p>
12	<p>Remove the cable harness out of the arm tube, at the back of the upper arm.</p> <p> Tip</p> <p>This step is best performed by two persons working together:</p> <ul style="list-style-type: none">• Person 1: Put one hand inside the side hole and take a hold of the cable harness.• Person 2: Take a hold on the cable harness at the back of the robot.• Together: Move the cable harness out of the arm tube. <p> Note</p> <p>To be able to remove the cable harness with the DressPack tube fitted, the tube needs to be pulled out a little, then be placed on the lower left side in the arm tube and the bracket of the cable harness then needs to be placed on the upper right hand side.</p> <p>(This is not needed on variants IRB 6700 - 300/2.70, -245/3.00)</p>	<p>Person 1, working at side hole:</p>  <p>xx130000745</p> <p>Person 2, working at the back:</p>  <p>xx1400002561</p>

Continues on next page

Attaching the lifting accessories to the upper arm

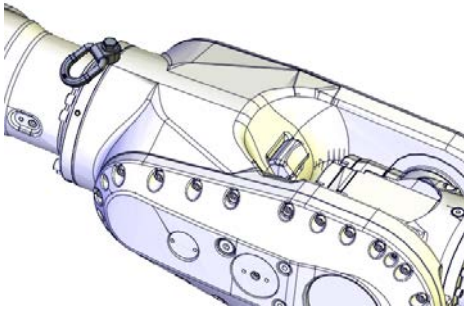
Use this procedure to attach the lifting accessories to the upper arm.

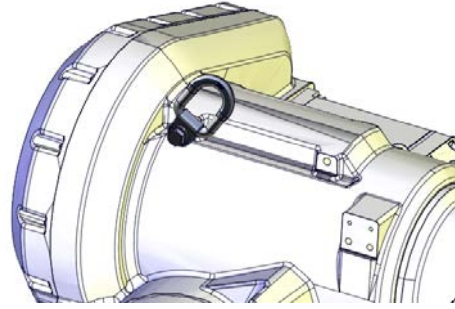
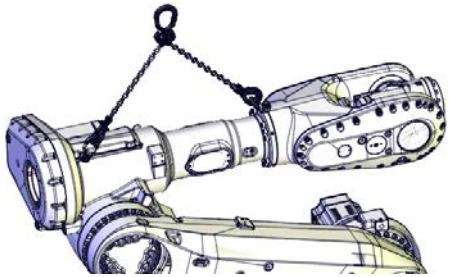
	Action	Note
1	<p> CAUTION</p> <p>The weight of the complete upper arm (including the wrist) is 360 kg (IRB 6700 -235/2.65, -205/2.80, -175/3.05, -150/3.20, -200/2.60, -155/2.85) 465 kg (IRB 6700 -300/2.70, -245/3.00) All lifting accessories used must be sized accordingly.</p>	
2	Fit a lifting eye to the wrist.	<p>Lifting eye: 3HAC16131-1</p>  <p>xx1200001133</p>
3	<p>Fit a lifting eye in the arm house, with a fender washer underneath.</p>  <p>xx1400002196</p>	<p>Lifting eye: 3HAC16131-1 Fender washer: Outer diameter: minimum 26 mm, maximum 30 mm, hole diameter: 13 mm, thickness: 3 mm.</p>  <p>xx1200001134</p>
4	Attach the upper arm lifting accessory (chain) to an overhead crane (or similar) and then to the lifting eye in the arm house and in the wrist.	<p>Lifting accessory (chain): 3HAC15556-1</p>  <p>xx1200001308</p>

Continues on next page



4 Repair

4.5.5 Replacing the lower arm

Continued

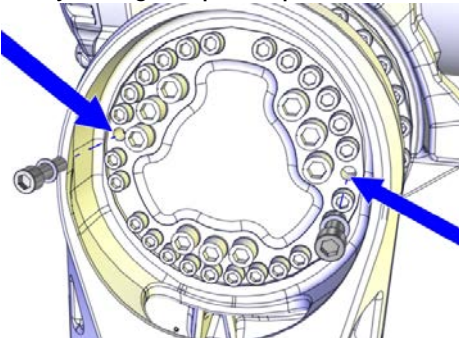
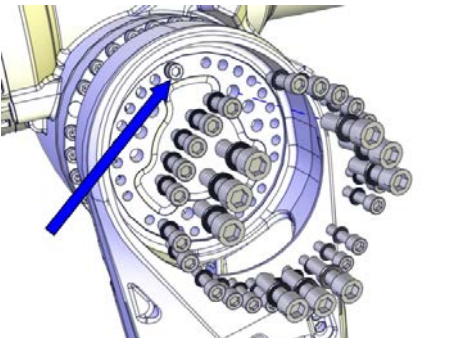

	Action	Note
5	Raise the lifting accessories to take the weight of the upper arm.	
6	In case of necessary adjustments, use the shortening loops on the lifting accessory (chain) to find the level position.	 <p data-bbox="943 730 1050 748">xx1400002197</p>

Preparations before removing the upper arm - IRB 6700 - 235/2.65, IRB 6700 - 205/2.80, IRB 6700 - 175/3.05, IRB 6700 - 150/3.20



	Action	Note
1	<p data-bbox="464 936 935 1016">Remove two attachment screws (M12) in opposite holes and replace them with guide pins.</p> <p data-bbox="464 1032 528 1093"> Note</p> <p data-bbox="464 1106 935 1187">Make sure that it is the screws that hold the lower arm to the axis-3 gearbox that are removed!</p> <p data-bbox="464 1202 528 1263"> Tip</p> <p data-bbox="464 1276 935 1357">Lubricate the guide pins with some grease to make the upper arm slide better.</p>	<p data-bbox="940 936 1404 1034">Guide pin, M12x150: 3HAC13056-2 Guide pin, M12x200: 3HAC13056-3 Always use guide pins in pairs.</p>  <p data-bbox="943 1379 1050 1397">xx130000659</p>
2	<p data-bbox="464 1435 935 1487">Leave one of the remaining attachment screws fitted, remove the other screws.</p>	 <p data-bbox="943 1774 1050 1792">xx130000747</p>

Continues on next page

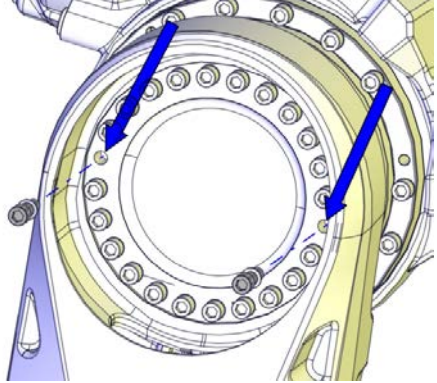
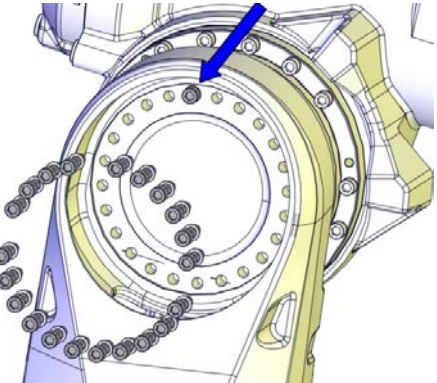
Preparations before removing the upper arm - IRB 6700 - 200/2.60, IRB 6700 - 155/2.85

	Action	Note
1	<p>Remove two attachment screws in opposite holes and replace them with guide pins.</p> <p> Note</p> <p>Make sure that it is the screws that hold the lower arm to the axis-3 gearbox that are removed!</p> <p> Tip</p> <p>Lubricate the guide pins with some grease to make the upper arm slide better.</p>	<p>Guide pin, M12x150: 3HAC13056-2 Guide pin, M12x200: 3HAC13056-3 Always use guide pins in pairs.</p>  <p>xx1300002245</p>
2	<p>Leave one of the remaining attachment screws fitted, remove the other screws.</p>	 <p>xx1300002246</p>

Preparations before removing the upper arm - IRB 6700 - 300/2.70, IRB 6700 - 245/3.00

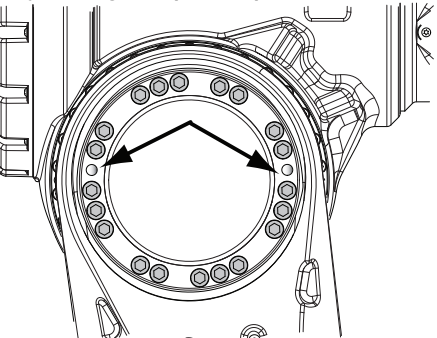
	Action	Note
1	<p>Remove two attachment screws in opposite holes and replace them with guide pins.</p> <p> Note</p> <p>Make sure that it is the screws that hold the lower arm to the axis-3 gearbox that are removed!</p> <p> Tip</p> <p>Lubricate the guide pins with some grease to make the upper arm slide better.</p>	<p>Guide pin, M16x150: 3HAC13120-2 Guide pin, M16x200: 3HAC13120-3 Always use guide pins in pairs.</p>  <p>xx1400002563</p>

Continues on next page



4 Repair

4.5.5 Replacing the lower arm

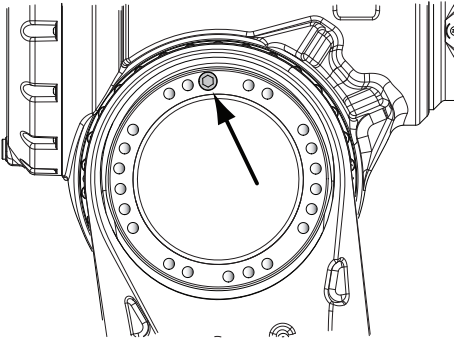

Continued

	Action	Note
2	Leave one of the remaining attachment screws fitted, remove the other screws.	 <p>xx1400002564</p>

Removing the upper arm

	Action	Note
1	 Note Make sure the lift is done completely leveled! In case of necessary adjustments, use the shortening loops on the lifting accessory (chain), and make sure to place the chain the right way through the loops.	 <p>xx1400002197</p>

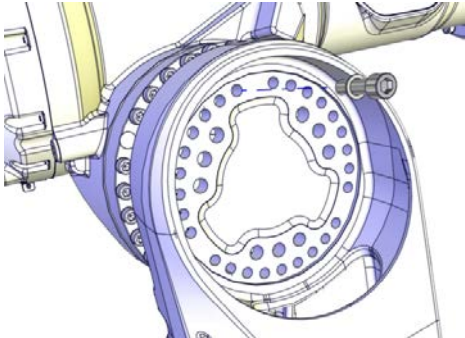
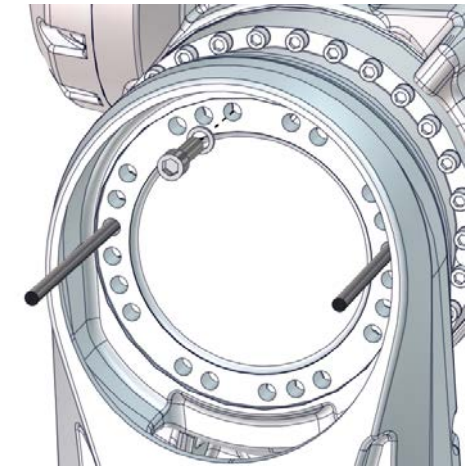
Continues on next page

	Action	Note
2	<p>Remove the remaining attachment screw and let the upper arm slide out from the lower arm with support from the guide pins.</p>	<p>IRB 6700 - 235/2.65, IRB 6700 - 205/2.80, IRB 6700 - 175/3.05, IRB 6700 - 150/3.20</p>  <p>xx1300001610</p> <p>IRB 6700 - 200/2.60, IRB 6700 - 155/2.85 TBD IRB 6700 - 300/2.70, IRB 6700 - 245/3.00</p>  <p>xx1700000059</p>
3	<p>Lift the upper arm and place it on the prepared area.</p> <p> CAUTION</p> <p><i>Only valid when the upper arm is removed due to replacement of the axis-3 gearbox:</i> If the cable harness is still fitted or partly fitted, use caution when lifting the upper arm over to the other side of the robot, in order not to cause any damage to the cable harness.</p>	

Continues on next page



4 Repair

4.5.5 Replacing the lower arm

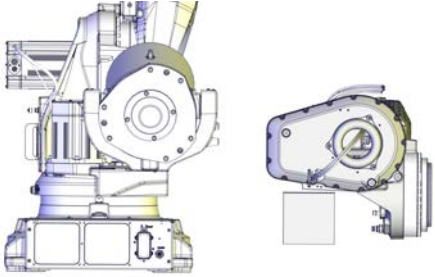

Continued

	Action	Note
4	<p><i>This step is only valid when the upper arm is removed due to replacement of the axis-3 gearbox:</i></p> <p>Place pieces of wood (or similar) under arm house and wrist. Lower the upper arm, and let the upper arm rest as shown in the figure.</p> <p>This is done in order to keep the axis-3 gearbox in a vertical position and to get the best position to replace the axis-3 gearbox, if applicable.</p>	 <p>xx1300000553</p>

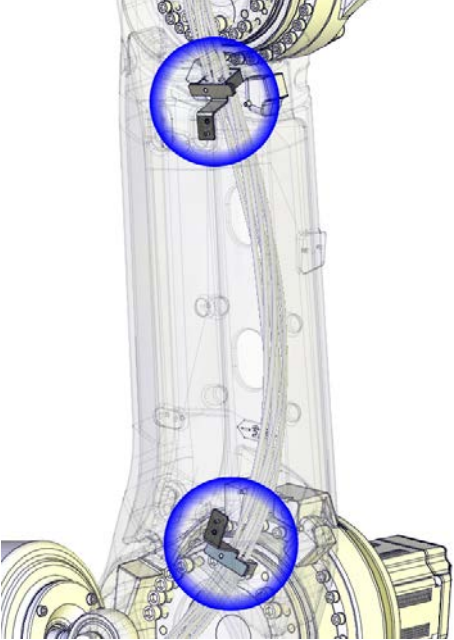

Preparations before removing the lower arm

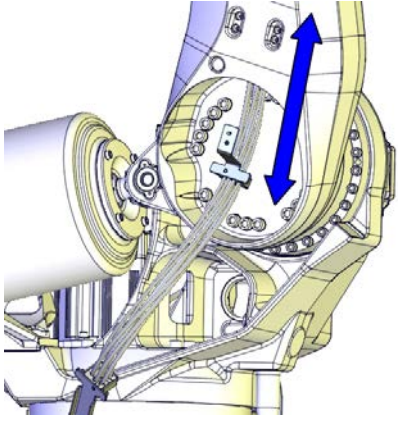
	Action	Note
1	 <p>DANGER</p> <p>Make sure that all supplies for electrical power, hydraulic pressure, and air pressure are turned off.</p>	
2	<p>Open the ball joint housings on the lower arm and remove the DressPack.</p>	
3	<p>Loosen the axis-2 lower arm metal clamp and the axis-3 lower arm metal clamp located on the inside of the lower arm by removing the attachment screws.</p>  <p>Note</p> <p>The screws are reached from outside the lower arm!</p>	 <p>xx1300000540</p>

Continues on next page

	Action	Note
4	Remove the cable harness from inside the lower arm.	 <p>xx130000733</p>
5	<p> CAUTION</p> <p>The lower arm weighs 145 kg (IRB 6700 - 235/2.65, - 205/2.80, - 175/3.05, - 150/3.20, - 200/2.60, - 155/2.85) 160 kg (IRB 6700 - 300/2.70, - 245/3.00) All lifting accessories used must be sized accordingly!</p>	
6	Apply the lifting accessory to the lower arm.	

Removing the lower arm - IRB 6700 - 235/2.65, IRB 6700 - 205/2.80, IRB 6700 - 175/3.05, IRB 6700 - 150/3.20, IRB 6700 - 200/2.60, IRB 6700 - 155/2.85

	Action	Note
1	Raise the lifting accessory to unload the lower arm.	
2	<p>Remove two attachment screws in opposite holes and replace them with guide pins.</p> <p> Tip</p> <p>Lubricate the guide pins with some grease to make the lower arm slide better.</p>	<p>Guide pin, M16x150: 3HAC13120-2 Guide pin, M16x200: 3HAC13120-3 Always use guide pins in pairs.</p>  <p>xx130000788</p>

Continues on next page

4 Repair

4.5.5 Replacing the lower arm

Continued

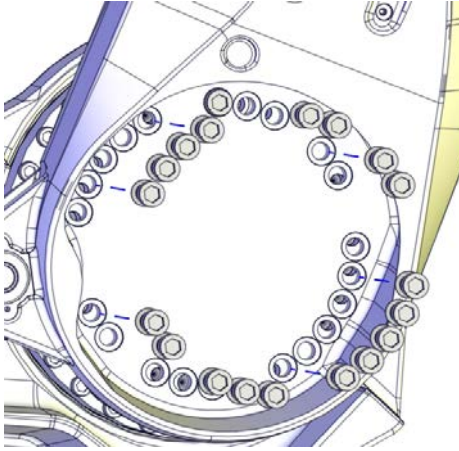
	Action	Note
3	Remove all but one of the remaining attachment screws and washers that secure the lower arm to the axis 2 gearbox.	 <p data-bbox="940 763 1050 779">xx130000789</p>
4	Make sure the lifting accessory is holding the weight of the arm system.	
5	Remove the remaining screw, slide the lower arm out on the guide pins and remove the lower arm.	

Removing the lower arm - IRB 6700 - 300/2.70, IRB 6700 - 245/3.00

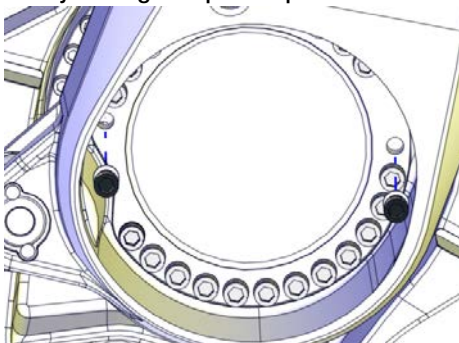
	Action	Note
1	Raise the lifting accessory to unload the lower arm.	
2	<p data-bbox="464 1167 932 1227">Remove two attachment screws in opposite holes and replace them with guide pins.</p> <p data-bbox="464 1234 598 1317">  Tip </p> <p data-bbox="464 1323 932 1384">Lubricate the guide pins with some grease to make the lower arm slide better.</p>	<p data-bbox="940 1167 1337 1200">Guide pin, M16x150: 3HAC13120-2</p> <p data-bbox="940 1200 1337 1234">Guide pin, M16x200: 3HAC13120-3</p> <p data-bbox="940 1234 1289 1267">Always use guide pins in pairs.</p>  <p data-bbox="940 1615 1050 1630">xx1400002181</p>

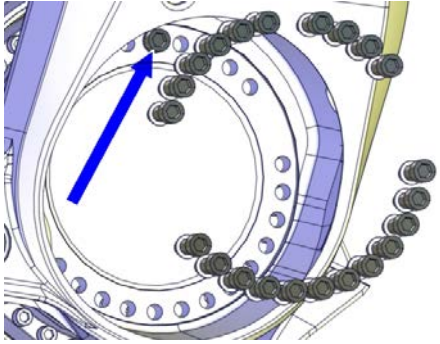

Continues on next page

	Action	Note
3	Remove all but one of the remaining attachment screws that secure the lower arm to the axis-2 gearbox.	 <p>xx1400002182</p>
4	Make sure the lifting accessory is holding the weight of the arm system.	
5	Remove the remaining screw, slide the lower arm out on the guide pins and remove the lower arm.	

Refitting the lower arm

Use these procedures to refit the lower arm.

Preparations before refitting the lower arm

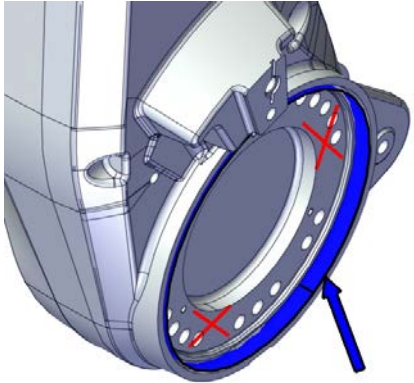



	Action	Note
1	 <p>DANGER</p> <p>Make sure that all supplies for electrical power, hydraulic pressure, and air pressure are turned off.</p>	
2	<p>Apply Mercasol on the surface on the lower arm as shown in the figure.</p>  <p>CAUTION</p> <p>Keep the sealing surfaces clean from Mercasol.</p>	<p>Rust preventive: 3HAC034903-001 (Mercasol 3110 Waxcoat. Recommended drying time is 24h.).</p>  <p>xx1700001879</p>

Continues on next page

4 Repair

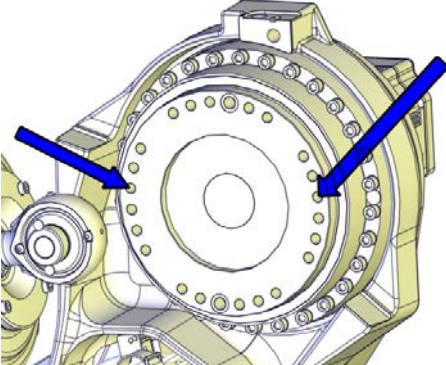

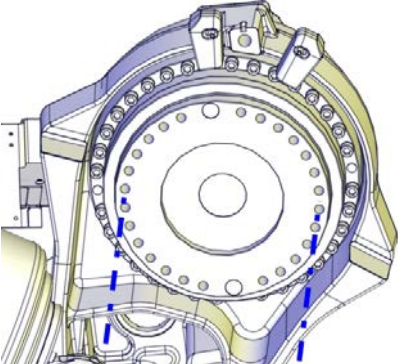
4.5.5 Replacing the lower arm

Continued

	Action	Note
3	<p>Valid for variants: IRB 6700 - 235/2.65, IRB 6700 - 205/2.80, IRB 6700 - 175/3.05, IRB 6700 - 150/3.20.</p> <p>Valid for variants: IRB 6700 - 200/2.60, IRB 6700 - 155/2.85.</p> <p>Fit two guide pins in opposite holes in the axis-2 gearbox.</p> <p> Tip</p> <p>Lubricate the guide pins with some grease to make the lower arm slide better.</p>	<p>Guide pin, M16x150: 3HAC13120-2</p> <p>Always use guide pins in pairs.</p>  <p>xx170000055</p>
4	<p>Valid for variants: IRB 6700 - 300/2.70, IRB 6700 - 245/3.00.</p> <p>Fit two guide pins in opposite holes in the axis-2 gearbox.</p> <p> Tip</p> <p>Lubricate the guide pins with some grease to make the lower arm slide better.</p>	<p>Guide pin, M16x150: 3HAC13120-2</p> <p>Always use guide pins in pairs.</p>  <p>xx1400002189</p>
5	<p> CAUTION</p> <p>The lower arm weighs .</p> <p>145 kg (IRB 6700 - 235/2.65, - 205/2.80, - 175/3.05, - 150/3.20, - 200/2.60, - 155/2.85)</p> <p>160 kg (IRB 6700 - 300/2.70, - 245/3.00)</p> <p>All lifting accessories used must be sized accordingly.</p>	
6	<p>Attach the lifting accessory to the lower arm.</p>	
7	<p>Wipe clean all contact surfaces.</p>	

Continues on next page

Securing the lower arm to the axis-2 gearbox - IRB 6700 - 235/2.65, IRB 6700 - 205/2.80, IRB 6700 - 175/3.05, IRB 6700 - 150/3.20, IRB 6700 - 200/2.60, IRB 6700 - 155/2.85

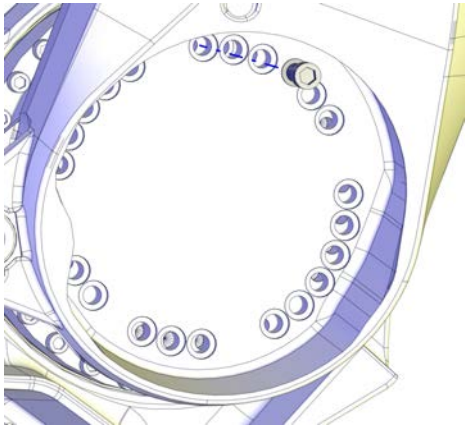

	Action	Note
1	<p> CAUTION</p> <p>The lower arm weighs . 145 kg (IRB 6700 - 235/2.65, - 205/2.80, - 175/3.05, - 150/3.20, - 200/2.60, - 155/2.85) 160 kg (IRB 6700 - 300/2.70, - 245/3.00) All lifting accessories used must be sized accordingly.</p>	
2	Lift the lower arm onto the guide pins and slide it into position.	
3	<p>In case the hole pattern of the lower arm and gearbox does not match:</p> <ul style="list-style-type: none"> • Remove the motor cover. • Apply the rotation tool on the motor shaft. • Connect the 24 VDC power supply. • Release the brakes. • Rotate pinion and gear with the rotational tool until the holes matches. <p>Connect 24 VDC the power supply to connector R2.MP2:</p> <ul style="list-style-type: none"> • + = pin 2 • - = pin 5 	<p>Rotation tool 24 VDC power supply</p>  <p>xx130000819</p>
4	Fit one attachment screw in one of the upper holes using it for security and lower the lifting accessory a little.	 <p>xx130000790</p>

Continues on next page

4 Repair

4.5.5 Replacing the lower arm

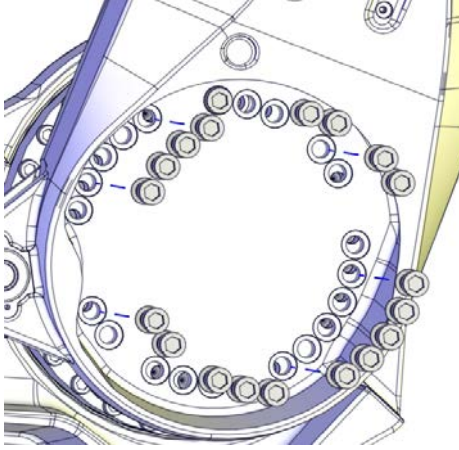
Continued

	Action	Note
5	Secure the lower arm with its attachment screws and washers.	Tightening torque M16: 300 Nm Attachment screws: M16x50 quality steel 12.9 Gleitmo (21 pcs) Washers: steel 17x25x3 (21 pcs)  xx1300000789
6	Disconnect the 24 VDC power supply (if used).	
7	Remove the guide pins and replace them with the remaining attachment screws.	 xx1300000788
8	Secure the remaining attachment screws.	Tightening torque M16: 300 Nm
9	Remove the lifting accessory from the lower arm.	

Securing the lower arm to the axis-2 gearbox - IRB 6700 - 300/2.70, IRB 6700 - 245/3.00

	Action	Note
1	Lift the lower arm onto the guide pins and slide it into position.	

Continues on next page

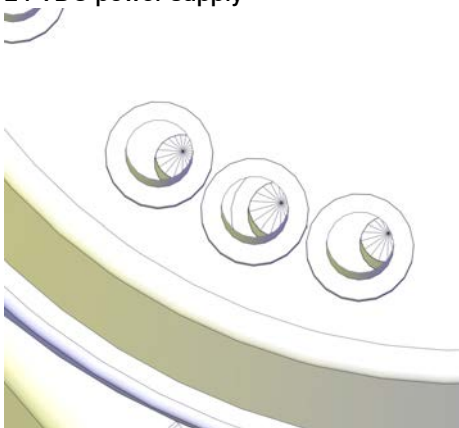
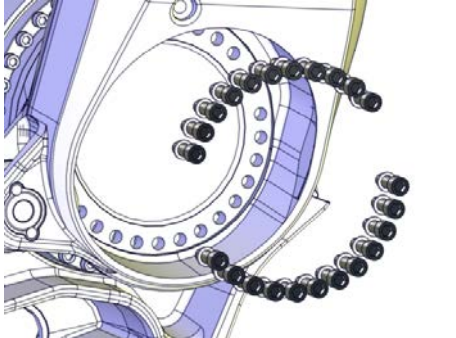
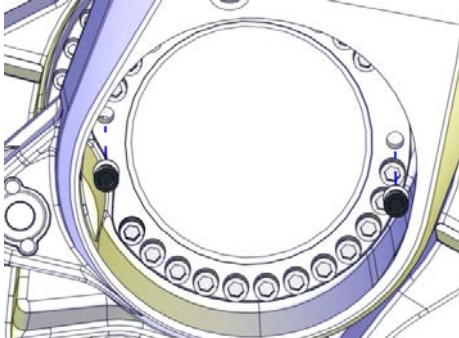
	Action	Note
2	<p>In case the hole pattern of the lower arm and gearbox does not match:</p> <ul style="list-style-type: none"> • Remove the motor cover. • Apply the rotation tool on the motor shaft. • Connect the 24 VDC power supply. • Release the brakes. • Rotate pinion and gear with the rotational tool until the holes matches. <p>Connect 24 VDC the power supply to connector R2.MP2:</p> <ul style="list-style-type: none"> • + = pin 2 • - = pin 5 	<p>Rotation tool 24 VDC power supply</p>  <p>xx1300000819</p>
3	<p>Fit one attachment screw in one of the upper holes using it for security and lower the lifting accessory a little.</p>	
4	<p>Secure the lower arm by fitting and tightening the accessible screws.</p>	<p>Tightening torque M16: 300 Nm Attachment screws: M16x50 quality steel 12.9 Gleitmo (21 pcs) Washers: steel 17x25x3 (21 pcs)</p>  <p>xx1400002190</p>
5	<p>Disconnect the 24 VDC power supply (if used).</p>	
6	<p>Remove the guide pins and replace them with the remaining attachment screws.</p>	 <p>xx1400002181</p>
7	<p>Secure the remaining attachment screws.</p>	<p>Tightening torque M16: 300 Nm</p>

Continues on next page



4 Repair

4.5.5 Replacing the lower arm

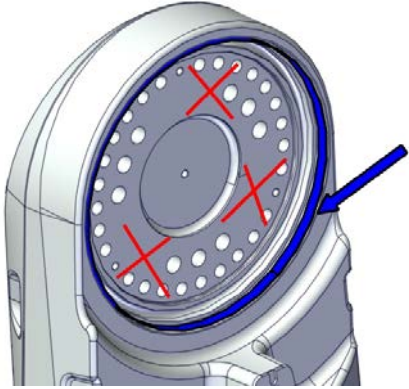

Continued

	Action	Note
8	Remove the lifting accessory from the lower arm.	

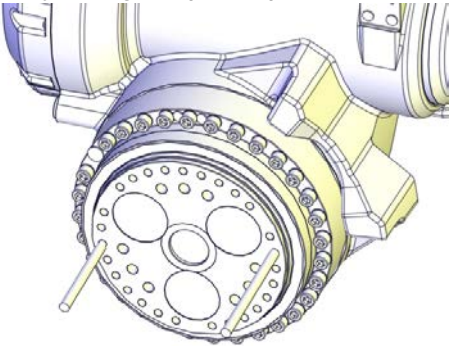
Preparations before refitting the upper arm

	Action	Note
1	Wipe clean all contact surfaces.	
2	<p><i>Foundry Plus:</i> Apply Mercasol on the surface on the lower arm as shown in the figure.</p> <p> CAUTION</p> <p>Keep the sealing surfaces clean from Mercasol.</p>	<p>Rust preventive: 3HAC034903-001 (Mercasol 3110 Waxcoat. Recommended drying time is 24h.)</p>  <p>xx1700001880</p>
3	<p>IRB 6700 - 235/2.65, IRB 6700 - 205/2.80, IRB 6700 - 175/3.05, IRB 6700 - 150/3.20</p> <p>Fit two guide pins in opposite M12 holes in the axis-3 gearbox.</p> <p> Tip</p> <p>Lubricate the guide pins with some grease to make the upper arm slide better.</p>	<p>Guide pin, M12x150: 3HAC13056-2 Guide pin, M12x200: 3HAC13056-3 Always use guide pins in pairs.</p>  <p>xx1700000058</p>

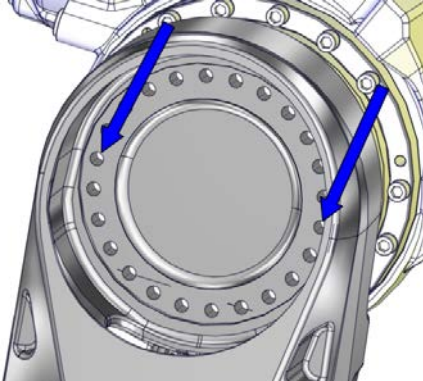
Continues on next page

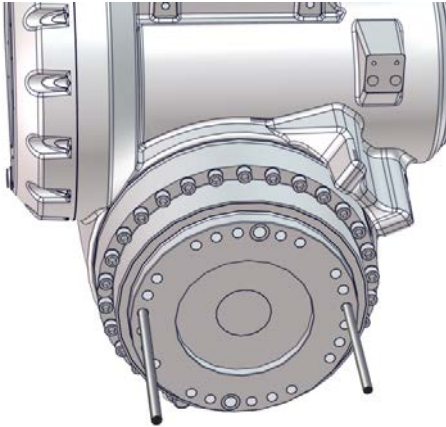
	Action	Note
4	<p>IRB 6700 - 200/2.60, IRB 6700 - 155/2.85 Fit two guide pins in opposite M12 holes in the axis-3 gearbox.</p> <p> Tip</p> <p>Lubricate the guide pins with some grease to make the upper arm slide better.</p>	<p>Guide pin, M12x150: 3HAC13056-2 Guide pin, M12x200: 3HAC13056-3 Always use guide pins in pairs.</p>  <p>xx1400000361</p>
5	<p>IRB 6700 - 300/2.70, IRB 6700 - 245/3.00 Fit two guide pins in opposite M16 holes in the axis-3 gearbox.</p> <p> Tip</p> <p>Lubricate the guide pins with some grease to make the upper arm slide better.</p>	<p>Guide pin, M16x150: 3HAC13120-2 Guide pin, M16x200: 3HAC13120-3 Always use guide pins in pairs.</p>  <p>xx1700000056</p>

Securing the upper arm - IRB 6700 - 235/2.65, IRB 6700 - 205/2.80, IRB 6700 - 175/3.05, IRB 6700 - 150/3.20

	Action	Note
1	<p> CAUTION</p> <p>The weight of the complete upper arm (including the wrist) is 360 kg (IRB 6700 -235/2.65, -205/2.80, -175/3.05, -150/3.20, -200/2.60, -155/2.85) 465 kg (IRB 6700 -300/2.70, -245/3.00) All lifting accessories used must be sized accordingly.</p>	
2	<p>Attach the lifting accessories, if not already fitted.</p>	<p>See Attaching lifting accessories to the upper arm on page 216.</p>

Continues on next page

4 Repair

4.5.5 Replacing the lower arm

Continued

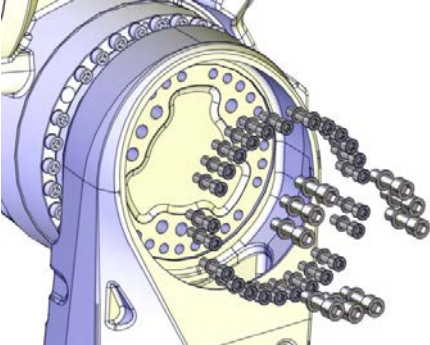
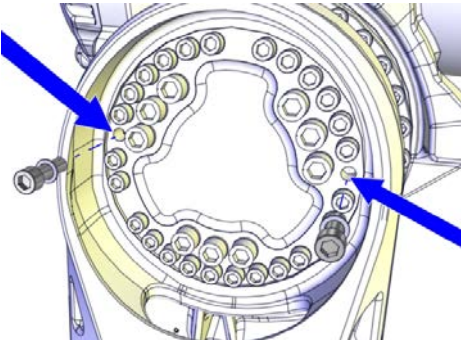
	Action	Note
3	Lift the upper arm and put it on the guide pins.	
4	<p>If the axis-3 motor is installed to the upper arm:</p> <p>In order to release the brakes, connect the 24 VDC power supply.</p> <p>Connect to R2.MP3-connector:</p> <ul style="list-style-type: none"> • + = pin 2 • - = pin 5 <p>Use the rotation tool and rotate the axis-3 motor to find the correct position for the guide pins in the lower arm.</p>	<p>24 VDC power supply</p> <p>Rotation tool</p>
5	<p>If the axis-3 motor is not installed to the upper arm:</p> <p>Use the pinion to rotate the axis-3 gearbox to find the correct position for the guide pins in the lower arm.</p>	<p>Pinion:</p> <p>3HAC067546-001 ⁱ</p> <p>3HAC067547-001 ⁱⁱ</p> <p>3HAC067545-001 ⁱⁱⁱ</p>
6	Insert all nine M16 screws and 25 of the 27 M12 screws.	<p>Screws:</p> <p>M16 (9 pcs)</p> <p>M12 (25 of 27 pcs)</p>  <p>xx1400000359</p>
7	Remove the guide pins and fit the two remaining M12 screws.	 <p>xx1300000659</p>
8	Secure the upper arm by tightening the attachment screws.	<p>Tightening torque depends on screw dimension.</p> <p>Tightening torque, M16: 300 Nm</p> <p>Tightening torque, M12: 120 Nm</p>

ⁱ IRB 6700 - 235/2.65, IRB 6700 - 205/2.80, IRB 6700 - 175/3.05, IRB 6700 - 150/3.20

ⁱⁱ IRB 6700 - 200/2.60, IRB 6700 - 155/2.85

ⁱⁱⁱ IRB 6700 - 300/2.70, IRB 6700 - 245/3.00

Continues on next page

Securing the upper arm - IRB 6700 - 200/2.60, IRB 6700 - 155/2.85

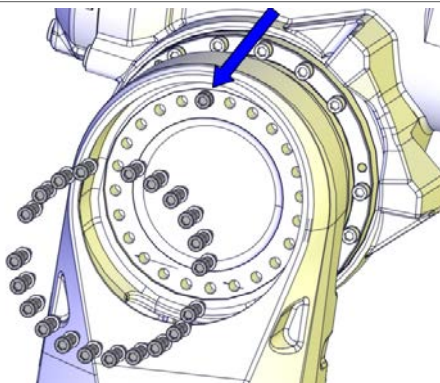
	Action	Note
1	<p> CAUTION</p> <p>The weight of the complete upper arm (including the wrist) is 360 kg (IRB 6700 -235/2.65, -205/2.80, -175/3.05, -150/3.20, -200/2.60, -155/2.85) 465 kg (IRB 6700 -300/2.70, -245/3.00) All lifting accessories used must be sized accordingly.</p>	
2	Attach the lifting accessories, if not already fitted.	See Attaching lifting accessories to the upper arm on page 216 .
3	Lift the upper arm and put it on the guide pins.	
4	<p>If the axis-3 motor is installed to the upper arm: In order to release the brakes, connect the 24 VDC power supply. Connect to R2.MP3-connector:</p> <ul style="list-style-type: none"> • + = pin 2 • - = pin 5 <p>Use the rotation tool and rotate the axis-3 motor to find the correct position for the guide pins in the lower arm.</p>	24 VDC power supply Rotation tool
5	<p>If the axis-3 motor is not installed to the upper arm: Use the pinion to rotate the axis-3 gearbox to find the correct position for the guide pins in the lower arm.</p>	Pinion: 3HAC067546-001 i 3HAC067547-001 ii 3HAC067545-001 iii
6	Insert 22 of the 24 M12 screws and washers.	 <p>xx1300002246</p>

Continues on next page

4 Repair

4.5.5 Replacing the lower arm

Continued

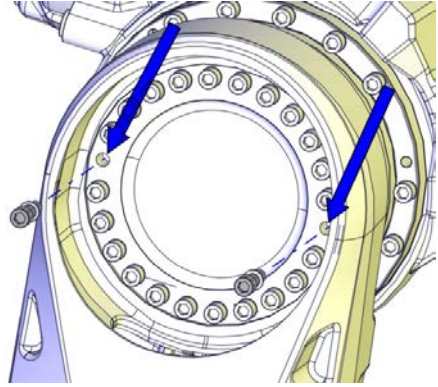
Action	Note
7 Remove the guide pins and fit the two remaining screws and washers.	 xx1300002245
8 Secure the upper arm by tightening the attachment screws.	M12, tightening torque: 120 Nm

i IRB 6700 - 235/2.65, IRB 6700 - 205/2.80, IRB 6700 - 175/3.05, IRB 6700 - 150/3.20

ii IRB 6700 - 200/2.60, IRB 6700 - 155/2.85

iii IRB 6700 - 300/2.70, IRB 6700 - 245/3.00

Securing the upper arm - IRB 6700 - 300/2.70, IRB 6700 - 245/3.00

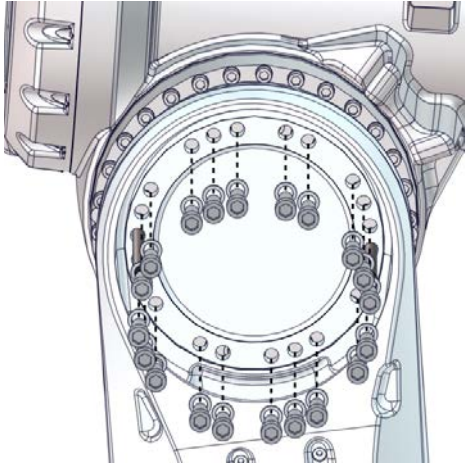

Action	Note
<p>1  CAUTION</p> <p>The weight of the complete upper arm (including the wrist) is 360 kg (IRB 6700 -235/2.65, -205/2.80, -175/3.05, -150/3.20, -200/2.60, -155/2.85) 465 kg (IRB 6700 -300/2.70, -245/3.00) All lifting accessories used must be sized accordingly.</p>	
2 Attach the lifting accessories, if not already fitted.	See Attaching lifting accessories to the upper arm on page 216 .
3 Lift the upper arm and bring it towards the lower arm.	
4 If the axis-3 motor is installed to the upper arm: Connect the 24 VDC power supply, to release the brakes. Connect to R2.MP3-connector: <ul style="list-style-type: none"> • + = pin 2 • - = pin 5 Use the rotation tool and rotate the axis-3 motor to find the correct position for the guide pins in the lower arm. Disconnect and remove the 24 VDC power supply after finding the position.	24 VDC power supply Rotation tool
5 If the axis-3 motor is not installed to the upper arm: Use the pinion to rotate the axis-3 gearbox to find the correct position for the guide pins in the lower arm.	Pinion: 3HAC067546-001 ⁱ 3HAC067547-001 ⁱⁱ 3HAC067545-001 ⁱⁱⁱ

Continues on next page

	Action	Note
6	Insert and tighten 20 of the 22 M16 screws.	 <p>xx170000057</p>
7	Remove the guide pins and fit the two remaining screws.	
8	Secure the upper arm by tightening the attachment screws.	M16, tightening torque: 300 Nm

- i IRB 6700 - 235/2.65, IRB 6700 - 205/2.80, IRB 6700 - 175/3.05, IRB 6700 - 150/3.20
- ii IRB 6700 - 200/2.60, IRB 6700 - 155/2.85
- iii IRB 6700 - 300/2.70, IRB 6700 - 245/3.00

Refitting the cable harness - lower arm

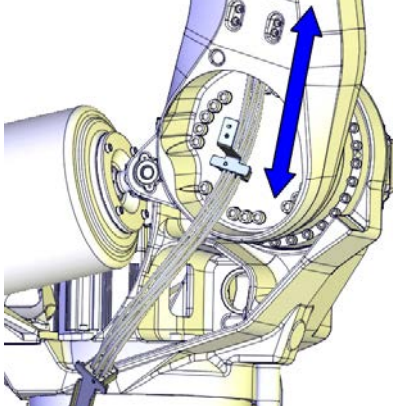



	Action	Note
1	 Tip Use tape and tie the axis-5 and axis-6 connectors and carrier into a bundle (if not already done). This is done to facilitate the procedure and to avoid damaging the parts during the procedure. This will also make it easier to run the cable harness through the inside of the robot.	 <p>xx130000668</p>
2	Run the upper end of the cable harness up through the lower arm.	 <p>xx130000733</p>

Continues on next page

4 Repair

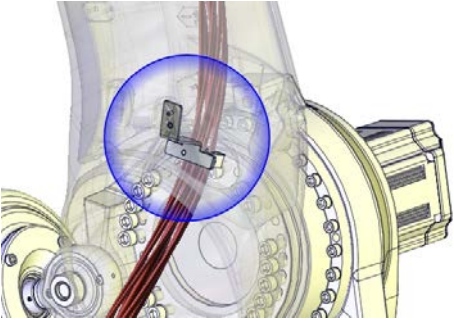

4.5.5 Replacing the lower arm

Continued

	Action	Note
3	<p>Refit the axis-2 lower arm metal clamp located on the inside of the lower arm.</p> <p> Note</p> <p>The screws are reached from the outside of the lower arm.</p>	 <p>xx130000734</p>
4	<p>Before fitting the remaining axis-3 lower arm cable bracket inside the lower arm, check that it will stay twisted a little between the metal clamps, after fitting, as shown in the figure. Do not change the position of the brackets!</p>	 <p>xx130000595</p>
5	<p>Refit the axis-3 lower arm metal clamp located on the inside of the lower arm.</p> <p> Note</p> <p>The screws are reached from the outside of the lower arm.</p>	 <p>xx130000558</p>

Continues on next page

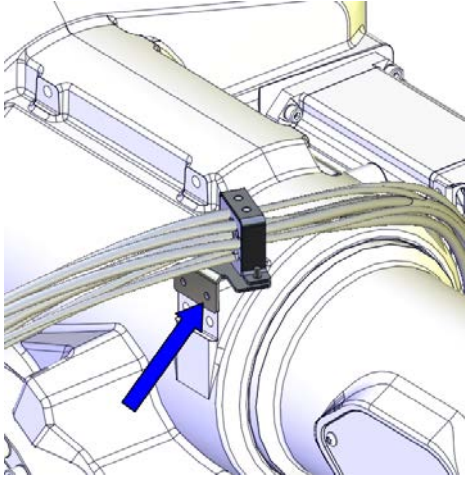
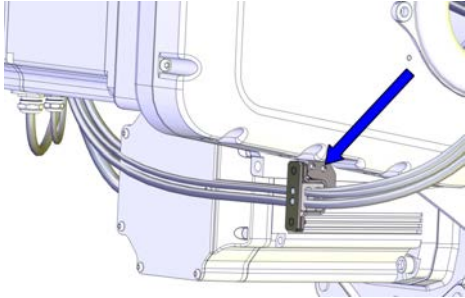
Refitting the cable harness - upper arm





	Action	Note
1	Refit the metal clamp on top of the arm house.	 <p>xx130000541</p>
2	Refit the arm house metal clamp.	 <p>xx130000543</p>
3	Arrange the cables between the cable clamps in the upper arm.	
4	 Tip Use tape and tie the axis-5 and axis-6 connectors and carrier into a bundle (if not already done). This is done to facilitate the procedure and to avoid damaging the parts during the procedure. This will also make it easier to run the cable harness through the inside of the robot.	 <p>xx130000668</p>

Continues on next page

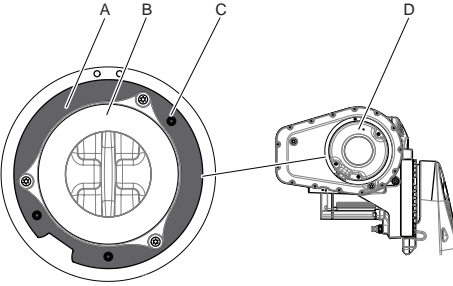

4 Repair

4.5.5 Replacing the lower arm

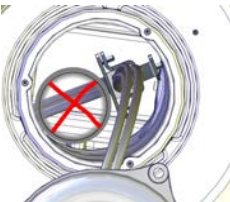
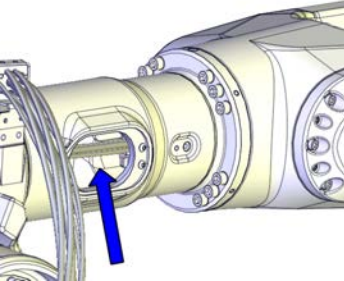
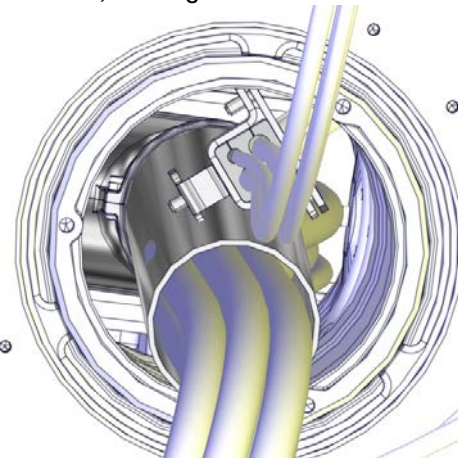
Continued

	Action	Note
5	<p>Foundry Plus: Make sure that the gasket underneath the cover is correctly fitted. Replace if damaged.</p> <p>The gasket is covered with adhesive on the side facing the upper arm cover. The three washers are pressed into the holes in the gasket. Make sure all three washers are fitted.</p>	 <p>xx140000382</p> <p>A Gasket B Cable guide C Washer D Cover</p>
6	<p>Run the cable harness through the cable guide and then into and through the upper arm tube.</p> <p> Tip</p> <p>This step is best performed by two persons working together:</p> <ul style="list-style-type: none"> • Person 1: Put one hand inside the side hole of the arm tube and take a hold of the cable harness. • Person 2: Take a hold on the cable harness at the back of the robot. • Together: Use caution and move the cable harness into the arm tube. <p> Note</p> <p>The cable harness is best placed at the upper right hand side of the DressPack tube, if used, through the arm tube.</p> <p>Do not run the cable harness into the DressPack tube!</p> <p> Note</p> <p>Do not run the cable harness into the DressPack tube, if one is fitted!</p>  <p>xx130000820</p>	<p>Person 1, working at the side hole:</p>  <p>xx130000745</p> <p>Person 2, working at the back:</p>  <p>xx140000356</p>

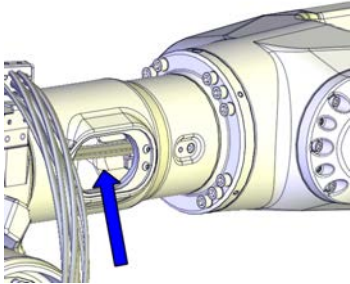
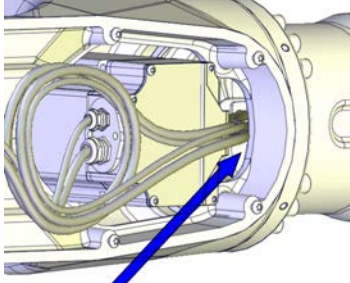
Continues on next page

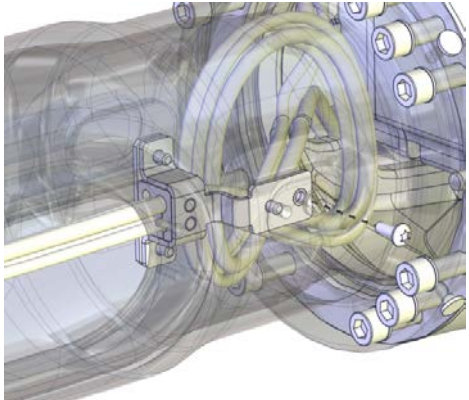
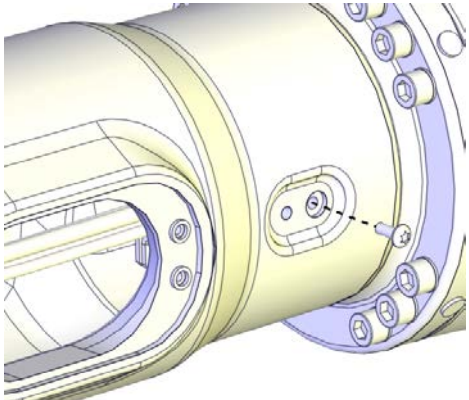
	Action	Note
7	<p>Use caution and push the cable harness into the wrist.</p> <p> Tip</p> <p>This step is best performed by two persons working together:</p> <ul style="list-style-type: none"> • Person 1: Put one hand inside the side cover hole and take a hold of the cable harness. • Person 2: Take a hold of the cable harness from inside the wrist. • Together: Move the cable harness past the axis-5 motor and into the wrist. 	<p>Person 1, working at the side hole:</p>  <p>xx130000745</p> <p>Person 2, working at the wrist:</p>  <p>xx130000746</p>
8	<p>Refit the metal clamp axis-4, inside the arm tube.</p> <p> Note</p> <p>The screws are reached from outside the upper arm.</p>	 <p>xx170000340</p>  <p>xx170000339</p>

Continues on next page



4 Repair

4.5.5 Replacing the lower arm

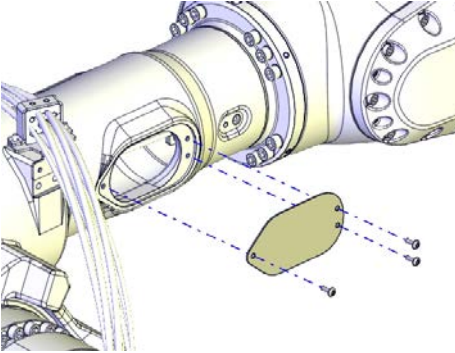
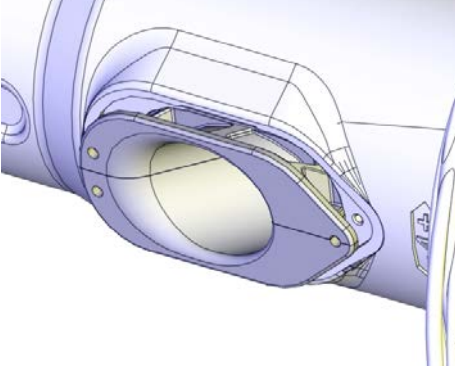
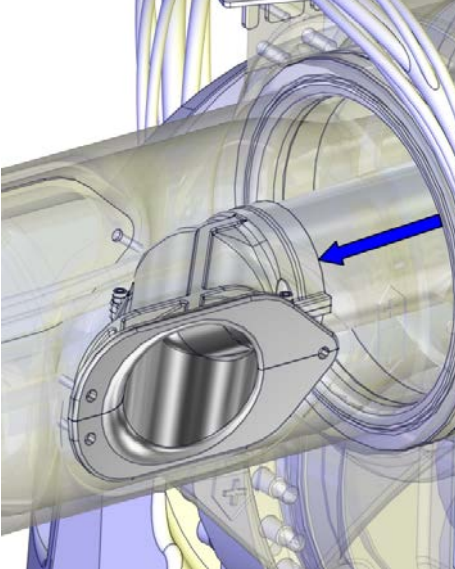
Continued

	Action	Note
9	<p>Refit the side cover.</p> <p> Note</p> <p><i>Foundry Plus:</i></p> <ul style="list-style-type: none">• Make sure the gasket is fitted correctly on the side cover• Use attachment screws made of stainless steel to fit the side cover.	 <p>xx130000557</p>
10	<p>If used, refit the insert that guides the DressPack cable package through the hole in the upper arm.</p>	 <p>xx170000690</p>
11	<p>If used, refit the tube containing the DressPack into the insert.</p>	 <p>xx140000092</p>

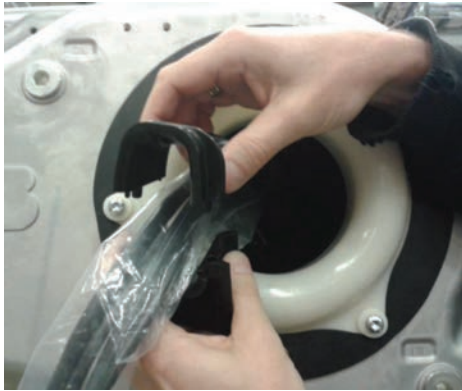
Continues on next page

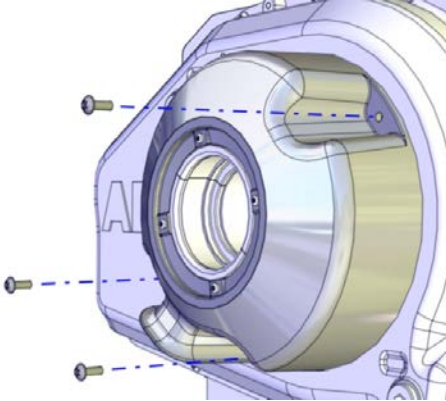
Action	Note
<p>12 Fit the cover insert around the new cabling and secure it with a weatherstrip.</p>	<p>Cover insert: 3HAC048520-001.</p>  <p>xx1700001803</p> <p>Weatherstrip: 3HAC053986-001.</p>  <p>xx1700001804</p>
<p>13 <i>DressPack</i> or <i>Foundry Plus</i>: Refit the cover with the tube guiding ring fitted.</p> <p> Note</p> <p><i>Foundry Plus</i>:</p> <ul style="list-style-type: none"> • Make sure the gasket is fitted correctly • Use attachment screws made of stainless steel to fit the cover. 	 <p>xx1200000045</p>

Continues on next page



4 Repair

4.5.5 Replacing the lower arm

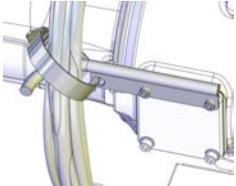
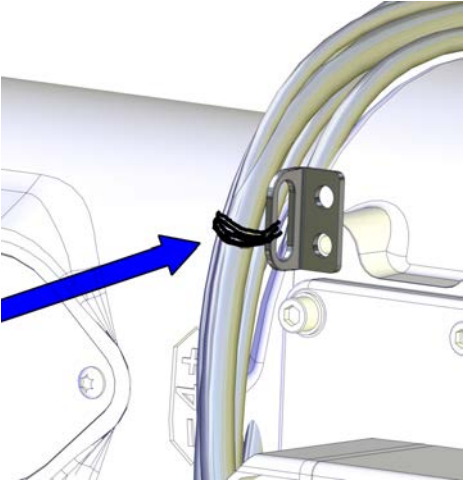

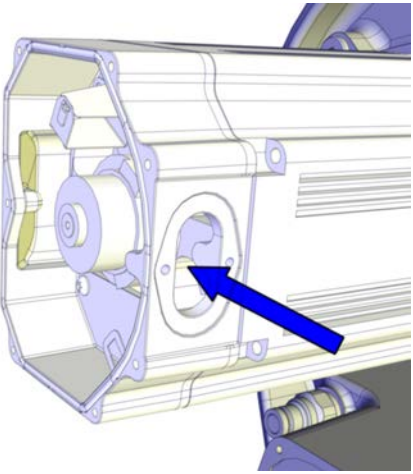

Continued

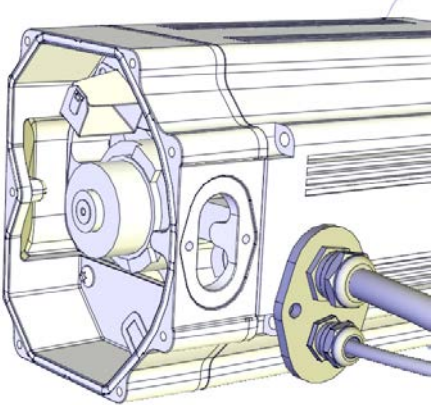
Action	Note
<p>14 Secure the cable harness to the cable fixing bracket with a cable tie.</p> <p> Note</p> <p>If DressPack is fitted, the cable fixing bracket is replaced by the cable guide.</p>  <p>xx1300001973</p>	 <p>xx130000544</p>

Connecting the axis-3 and axis-4 motor cables

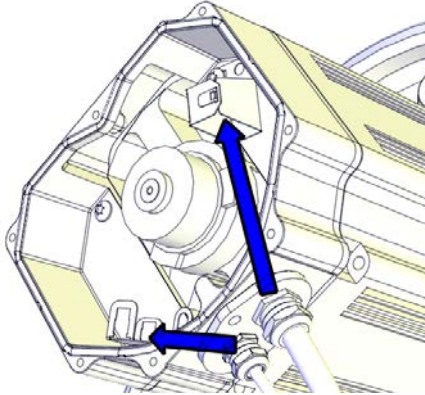
Action	Note
<p>1 Push the motor cables through the cable gland opening.</p>	 <p>xx130000738</p>
<p>2 Refit the cable gland cover.</p> <p> Note</p> <p>Replace the gasket if damaged.</p>	 <p>xx1200001067</p>

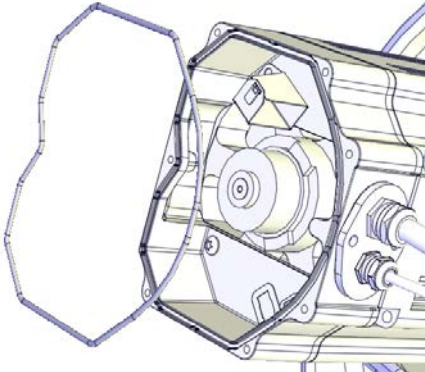
Continues on next page



	Action	Note
3	Connect the motor cables. Connect in accordance with the markings on the connectors.	 <small>xx1200001066</small>
4	Inspect the o-ring.  Note Replace if damaged.	O-ring, axis-1: 3HAB3772-111 (circular profile) / 3HAC054692-002 (hexagon profile) O-ring, axis-2: 3HAB3772-111 (circular profile) / 3HAC054692-002 (hexagon profile) O-ring, axis-3: 3HAB3772-111 (circular profile) / 3HAC054692-002 (hexagon profile) O-ring, axis-4: 3HAB3772-110 (circular profile) / 3HAC054692-001 (hexagon profile)  <small>xx1200001070</small>
5	Wipe clean o-ring and o-ring groove.	
6	Refit the o-ring.  Tip Lubricate the o-ring with some grease for a better fitting in the groove.	
7	 CAUTION When fitting the motor cover, make sure that none of the cables inside will be damaged.	

Continues on next page



4 Repair

4.5.5 Replacing the lower arm

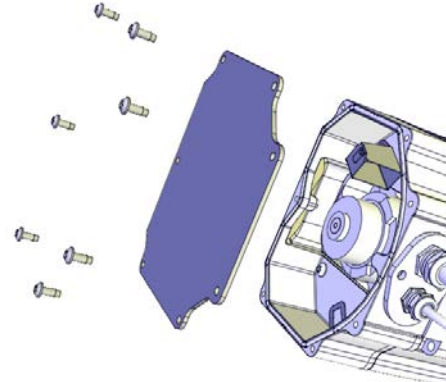

Continued

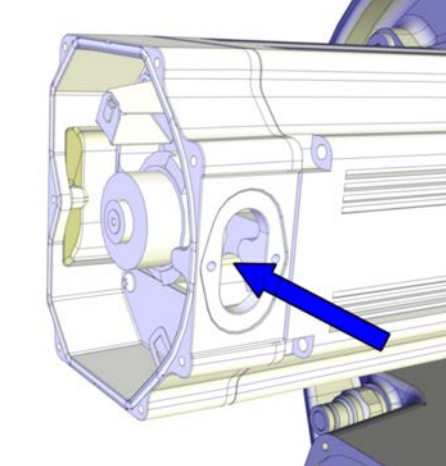
	Action	Note
8	<p>Refit the motor cover with its attachment screws.</p> <p> Note</p> <p>Do not reuse the self-threading attachment screws. Replace with standard attachment screws or the threads will be damaged.</p> <p> Note</p> <p>Make sure the o-ring is undamaged and properly fitted.</p>	<p>Attachment screws: M5x12 8.8 (7 pcs)</p>  <p>xx1200001135</p>
9	<p>Make sure that the covers are tightly sealed.</p>	

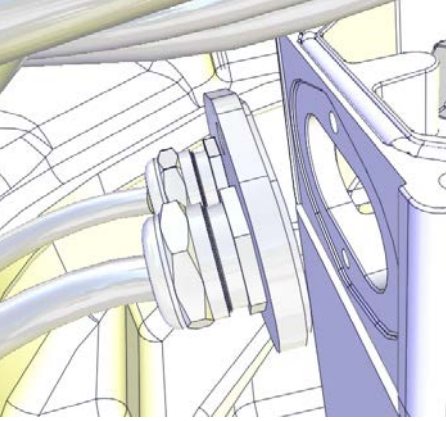
Connecting the axis-5 motor cables

	Action	Note
1	<p>Push the motor cables in through the cable gland opening.</p>	 <p>xx1300000738</p>
2	<p>Refit the cable gland cover by performing the following steps:</p> <ul style="list-style-type: none">• Slide the cable gland cover onto the inner screw.• Refit and tighten the outer screw.• Tighten the inner screw. Make sure that the gasket is not damaged. <p> Note</p> <p>Replace the gasket if damaged.</p>	 <p>xx1200001016</p>

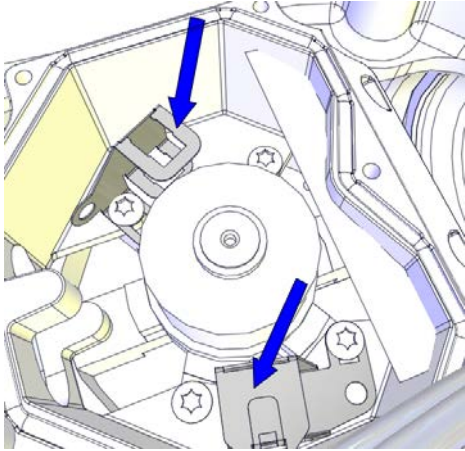
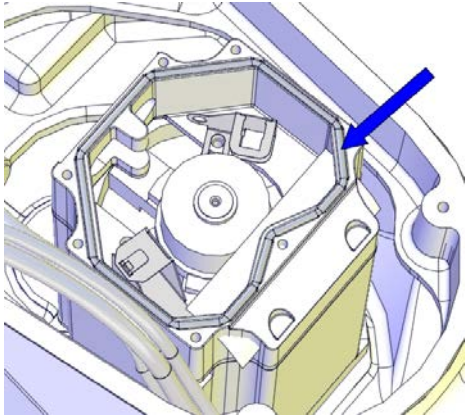



Continues on next page

	Action	Note
3	<p>Connect the connectors. Connect in accordance with the markings on the connectors.</p>	 <p>xx1200001015</p>
4	<p>Make sure the o-ring on the motor is undamaged. Replace if damaged.</p>	 <p>xx1200001021</p>
5	<p> CAUTION When fitting the motor cover, make sure that none of the cables inside will be damaged.</p>	

4 Repair

4.5.5 Replacing the lower arm

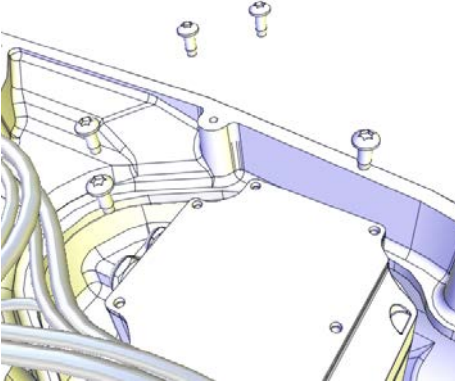
Continued

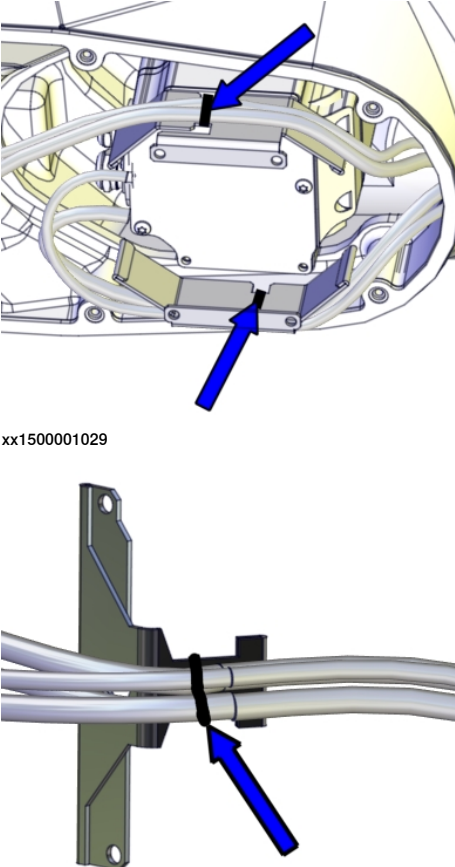
	Action	Note
6	<p>Refit the motor cover with its attachment screws.</p> <p> Note</p> <p>Do not refit the screws that will hold the heat protection plate at this point.</p> <p> Note</p> <p>Do not reuse the self-threading attachment screws, it will damage the threads. Replace with standard attachment screws.</p> <p> Note</p> <p>Make sure the o-ring is undamaged and properly fitted.</p>	<p>Screws: M5x12.</p>  <p>xx1200001013</p>
7	<p>Secure the cable harness with cable straps to the heat protection plate.</p> <p> Note</p> <p>If replacing a type A motor with a type B motor, the heat protection plate must be replaced with plates suited for the type B motor. See Type A vs type B motors on page 805.</p>	<p>There are two versions of the heat protection plates. Choose figure depending on which plate is installed on the robot.</p>  <p>xx1500001029</p> <p>xx1300000489</p>

Continues on next page

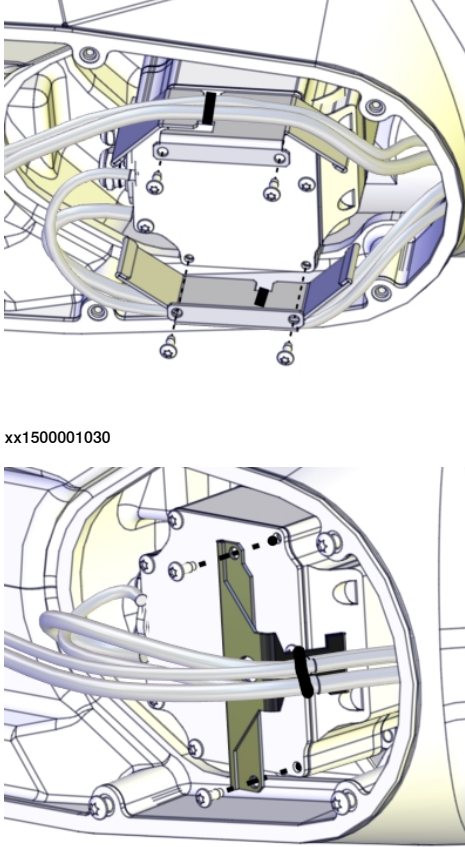
	Action	Note
8	Fit the heat protection plate with the screws.	<p>Choose figure depending on which plate is installed on the robot. Screws: M5x12.</p>  <p>xx1500001030</p> <p>xx1300000490</p>



Continues on next page

4 Repair

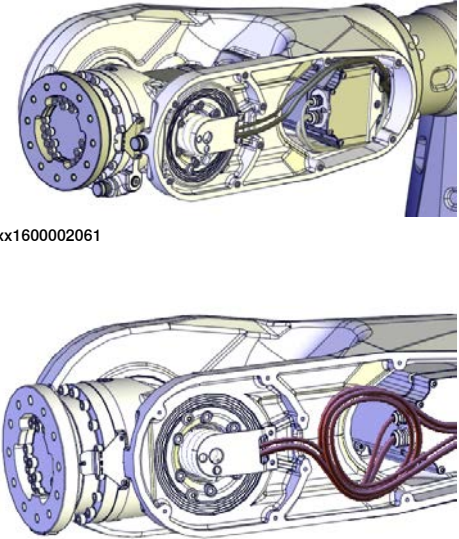

4.5.5 Replacing the lower arm

Continued

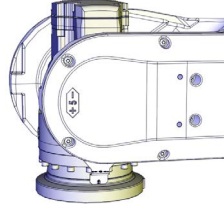
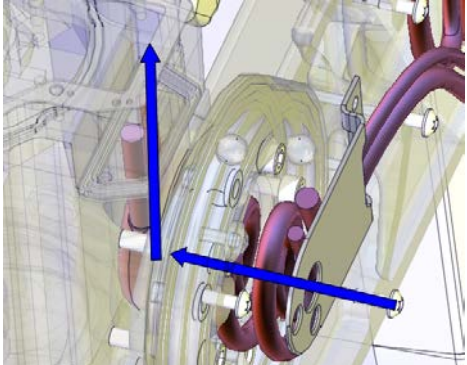
Connecting the axis-6 motor cables

	Action	Note
1	<p>Make sure that the cable harness is placed in a way that it will not be damaged when the cover is fitted.</p>	 <p>xx1600002061</p> <p>xx1300000596</p> <p>Cable layout in the wrist with Type A motors.</p>
2	<p> Note</p> <p>Axis 5 must be in position $+90^\circ$ (or as close as possible) for a correct installation of the cable harness in the wrist. If not, connect the 24 VDC power supply, release the brakes and move axis 5 manually to $+90^\circ$.</p>	 <p>xx1200001081</p>
3	<p>Push the cable harness into the wrist recess and up into the axis-6 motor.</p>	 <p>xx1300000667</p>

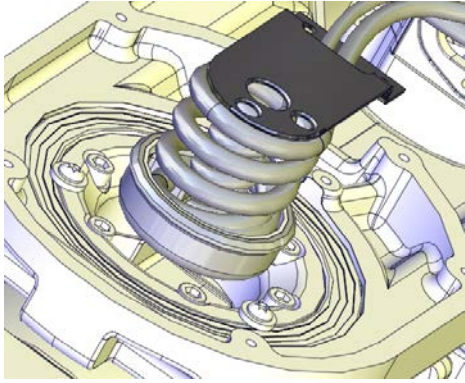
Continues on next page

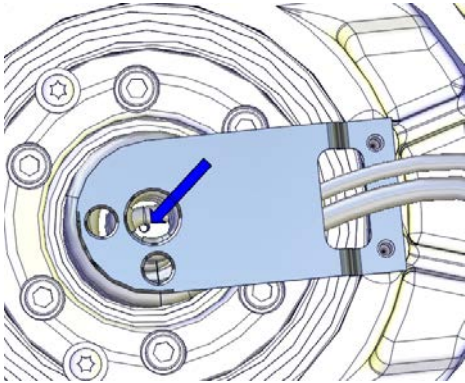
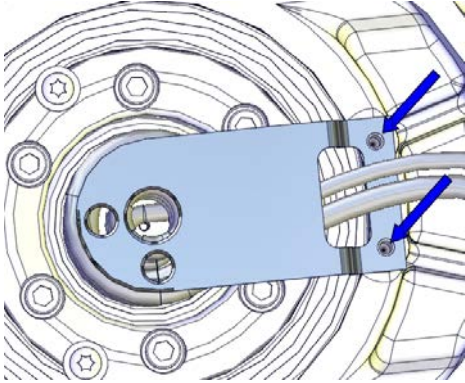

	Action	Note
4	Push the carrier carefully into position.	 <p data-bbox="970 696 1082 719">xx1300001113</p>
5	Secure the carrier with the M4 screw.  Note The screw is located at the bottom of the carrier.  Tip The attachment screw securing the carrier may be difficult to fit. Make sure the carrier is level and completely pressed against the bottom.	 <p data-bbox="970 1131 1082 1153">xx1300000485</p>
6	Secure the cable bracket with its attachment screws.	 <p data-bbox="970 1570 1082 1592">xx1300000484</p>

Continues on next page

4 Repair

4.5.5 Replacing the lower arm

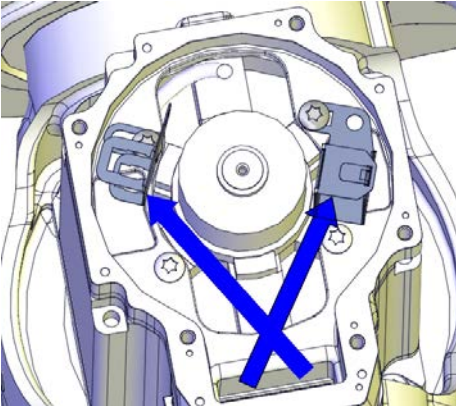
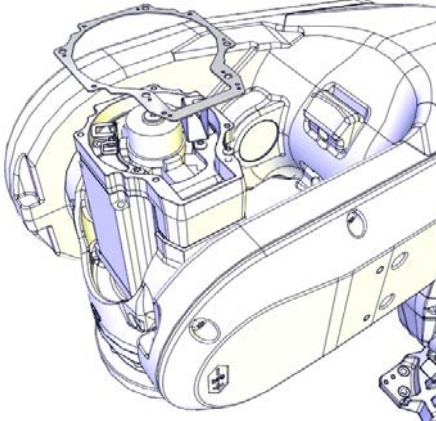
Continued

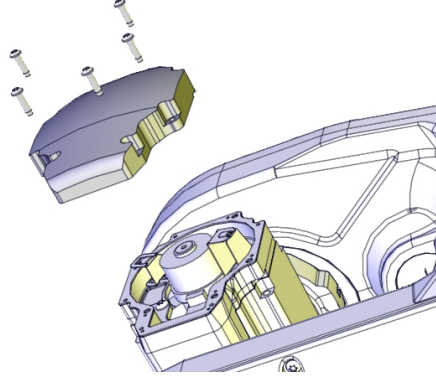
	Action	Note
7	<p>Reconnect the connectors to the axis-6 motor.</p> <p> Note</p> <p>Place the resolver cable under the motor cable.</p>	 <p>xx130000488</p>
8	<p>Make sure the gasket is undamaged. Replace if damaged.</p>	<p>Gasket, 3HAC033489-001/ 3HAC044252-001</p>  <p>xx1200001095</p>
9	<p> CAUTION</p> <p>When fitting the motor cover, make sure that none of the cables inside will be damaged.</p>	
10	<p>Refit the motor cover.</p>	 <p>xx1200001080</p>

Continues on next page

Concluded refitting of the cable harness

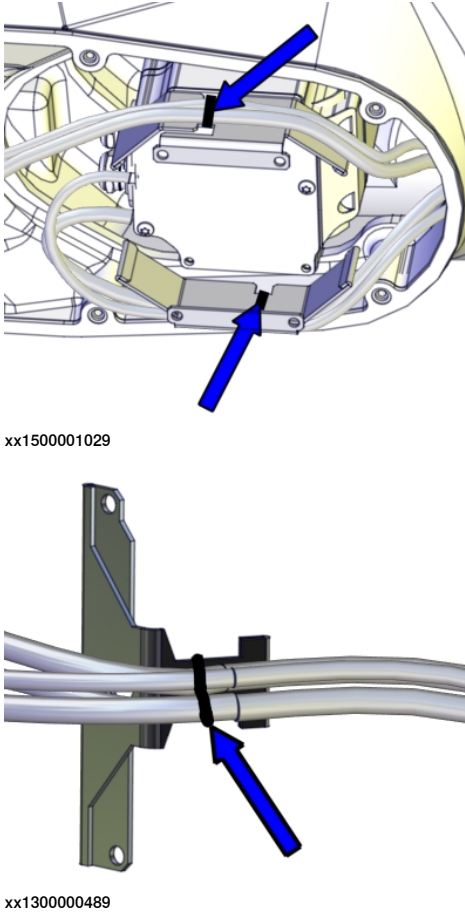
	Action	Note
1	Secure the cable harness with cable straps to the heat protection plate.	<p>There are two versions of the heat protection plates. Choose figure depending on which plate is installed on the robot.</p>  <p>xx1500001029</p> <p>xx130000489</p>

Continues on next page

4 Repair

4.5.5 Replacing the lower arm

Continued

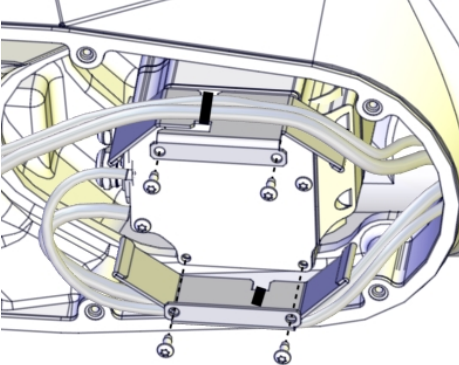
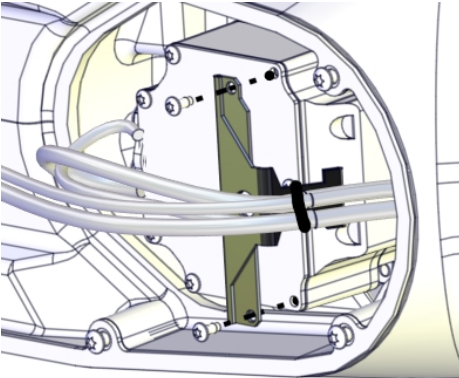
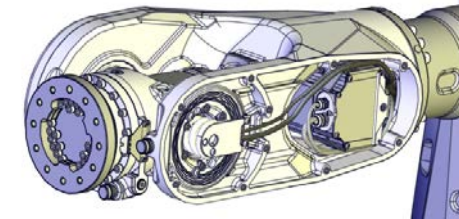
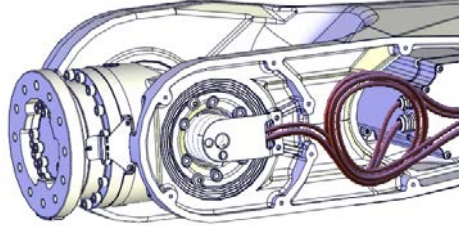
	Action	Note
2	Fit the heat protection plate with the screws.	<p data-bbox="943 315 1398 367">Choose figure depending on which plate is installed on the robot.</p>  <p data-bbox="943 797 1050 815">xx1500001030</p>  <p data-bbox="943 1238 1050 1256">xx1300000490</p>
3	Make sure that the cable harness is placed so it will not be damaged when the wrist cover is fitted.	 <p data-bbox="943 1547 1050 1565">xx1600002061</p>  <p data-bbox="943 1912 1050 1930">xx1300000596</p> <p data-bbox="943 1951 1398 2002">Cable layout in the wrist with Type A motors.</p>

Continues on next page

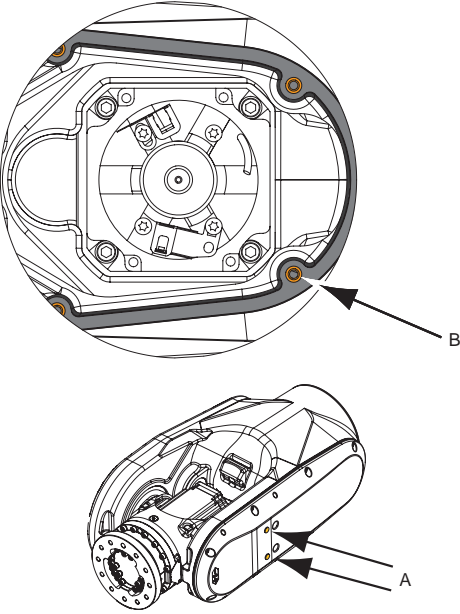
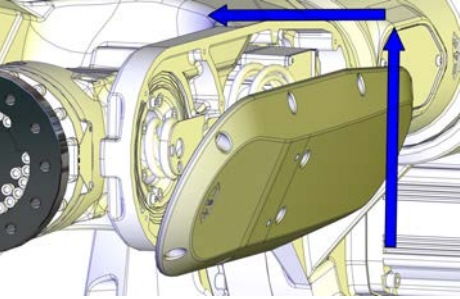
	Action	Note
4	<p>Foundry Plus: Inspect the gasket. Replace if damaged. Put washers in the holes of the gasket.</p>	 <p>xx140000383</p> <p>A Protection plugs (2 on wrist cover and 2 on cover axis-5 gearbox) B Washers (10 pcs) in gasket holes</p>
5	<p>Use caution in order not to damage the cable harness when the wrist cover is refitted, by following this method:</p> <ol style="list-style-type: none"> 1 Hold the cover tilted. See figure! 2 Put the cable harness on the cover. 3 Lift the cover, still tilted. 4 Move the upper part of the cover into position. 5 Secure the cover with its attachment screws. 	 <p>xx130000772</p> <p>Tightening torque: 10 Nm.</p>
6	<p>If the robot is equipped with DressPack cable package:</p> <ul style="list-style-type: none"> • Refit the distance to the wrist cover. • Refit the ball joint housing to the distance. • Refit the bracket with the ball joint housing to the upper arm tube. • Refit the process turning disk. 	<p>How to refit the DressPack cable package is described in the product manual "IRB 6700 DressPack". For article number see References on page 10.</p>

4 Repair

4.5.5 Replacing the lower arm

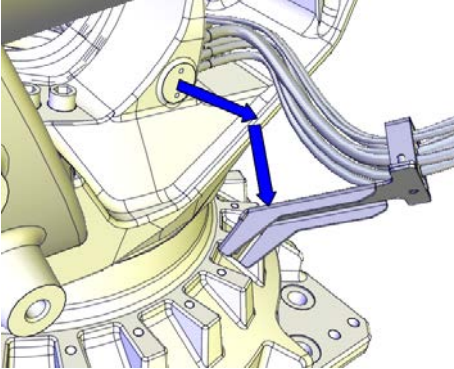
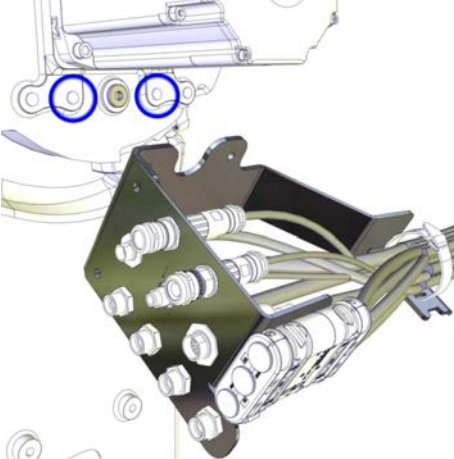
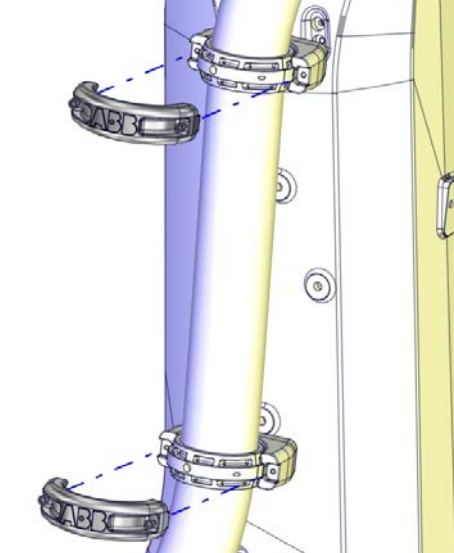

Continued

	Action	Note
7	Refit the bracket to the frame.	 <p>xx1200001184</p>
8	Refit the connection plate.	 <p>xx1200001332</p>
9	If used, refit the DressPack in the ball joint housings on the lower arm.	 <p>xx1400000195</p>

Refitting the front shaft of the balancing device

	Action	Note
1	Turn the power to the robot on temporarily.	

Continues on next page

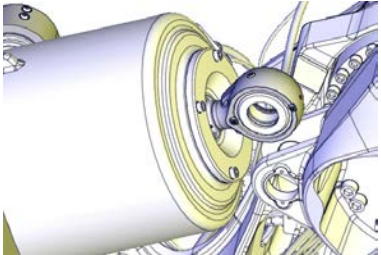
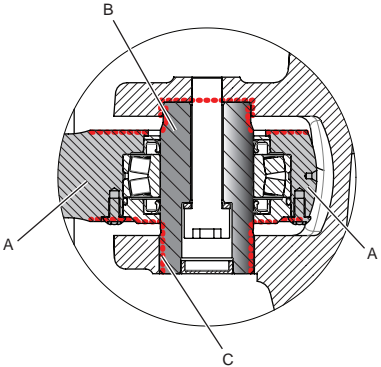

	Action	Note
2	Use caution and jog the robot to the calibration position (if not already done).	
3	 DANGER Turn off all: <ul style="list-style-type: none"> • electric power supply • hydraulic pressure supply • air pressure supply to the robot, before entering the robot working area.	
4	Apply the lifting accessory to the balancing device (if not already done).	Lifting shackle: SA-10-8-NA1 Lifting accessory (chain): 3HAC15556-1
5	Remove all residue of Loctite in the screw hole of the shaft.	
6	Wipe all contact surfaces inside the recess clean from contamination.	
7	Align the balancing device link ear with the hole in the lower arm.  Note Verify that the link ear is correctly turned.	 xx1300000784
8	<i>Foundry Plus:</i> Apply Mercasol on the surfaces on the shaft and front ear.	 xx1400000368 A Front link ear B Shaft C Mercasol (red dotted lines)

Continues on next page

4 Repair

4.5.5 Replacing the lower arm

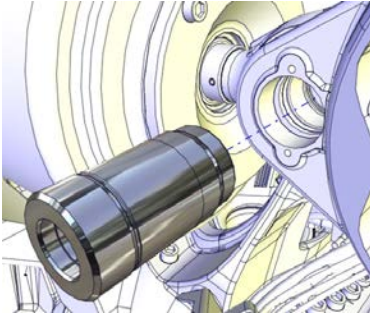
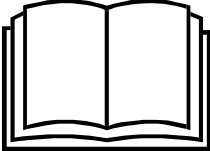
Continued

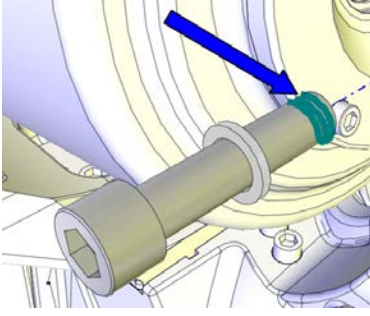
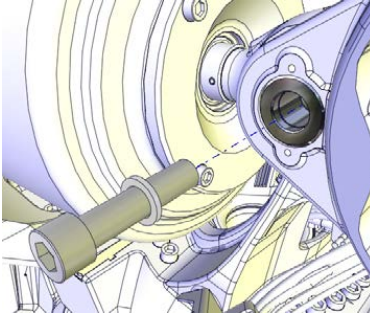
	Action	Note
9	Lubricate the shaft and place it to the front ear.  Note <i>Foundry Plus:</i> Do not lubricate surfaces where Mercasol is applied.	 xx1200001280
10	Press in the shaft using the dismantle and mounting tool, according to user instructions enclosed with the equipment.  xx0900000813 Go to the user instructions enclosed with the press tool.  DANGER Handling the tool incorrectly will cause serious injury. Read and follow enclosed user instructions for the tool.	Dismantle and mounting tool: 3HAC028920-001 User instructions are enclosed with the tool.
11	Apply locking liquid (Loctite 2701) on the threads of the screw, first entering the threads in the frame.	 xx1300000782
12	Secure the shaft with screw and washer.	Tightening torque: 180 Nm  xx1200001279

Continues on next page

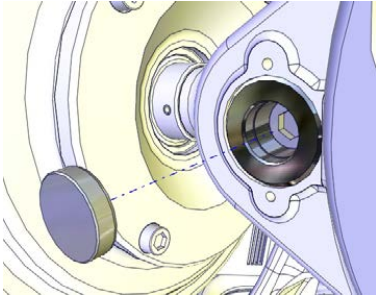
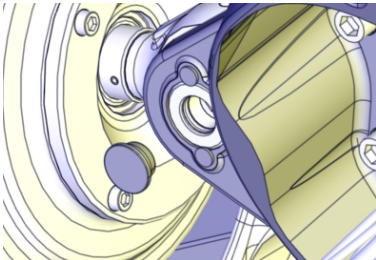
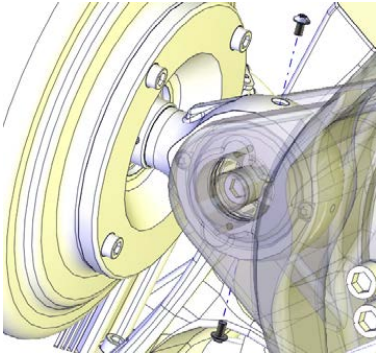
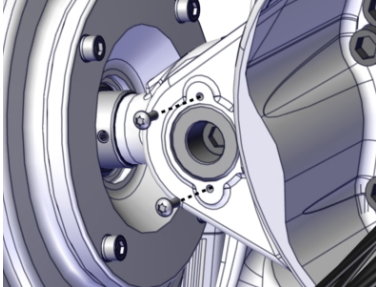
	Action	Note
13	Fit the protection plug or a new VK-cover (depends on shaft version).	 <p>xx1200001278</p>  <p>xx1900002311</p>
14	Unscrew both screws in link ear and fill the bearing with grease from the upper hole until the grease appears in the lower hole.	<p>Grease: 3HAA1001-294</p>  <p>xx1300000783</p>
15	Refit the two screws and wipe clean from residual grease.	<p>Tightening torque: 180 Nm</p>  <p>xx1900002146</p>

Concluded refitting of the front shaft



	Action	Note
1	Remove the lifting accessory from the balancing device.	

Continues on next page

4 Repair

4.5.5 Replacing the lower arm

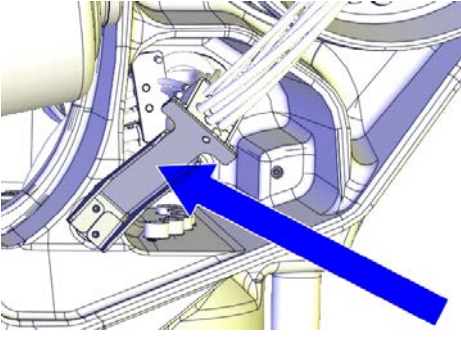
Continued

	Action	Note
2	Refit the cable bracket (if not already refitted).	 xx1200001283
3	 DANGER Do not use the Distance tool: 3HAC030662-001 to unload or restore the pressure of the balancing device spring unit! This tool is only used to lock the spring unit in a compressed position, after axis-2 has been jogged to -20° or $+20^\circ$. Fitting and removal of the tool shall only be done with axis-2 in this position! To unload or restore a new balancing device or if the spring unit of the balancing device cannot be compressed by jogging the robot, only use the hydraulic press tool Dismantle and mounting tool 3HAC028920-001.	
4	Jog axis-2 to: <ul style="list-style-type: none">• -30° or $+30^\circ$.	This is done in order to compress the spring unit inside the balancing device before refitting or removal of the distance tool.
5	 DANGER Turn off all: <ul style="list-style-type: none">• electric power supply• hydraulic pressure supply• air pressure supply to the robot, before entering the robot working area.	

Continues on next page

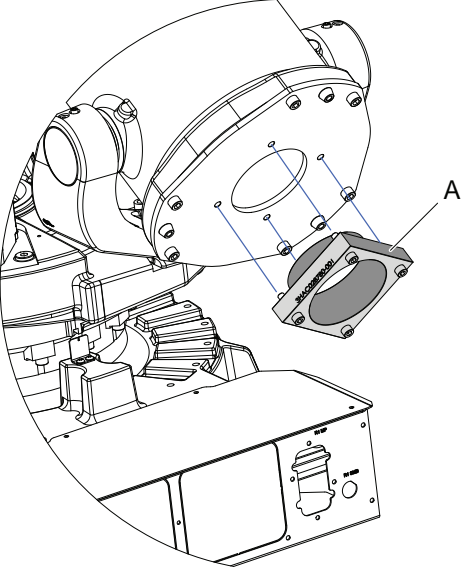
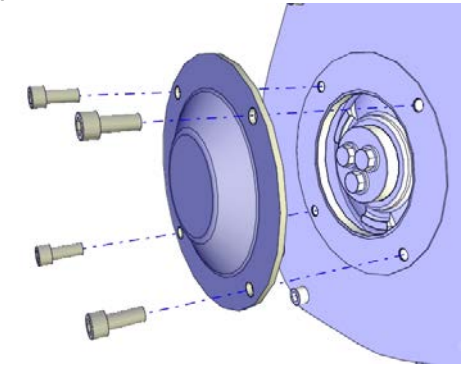
	Action	Note
6	Remove the distance tool.	 <p>xx080000480</p> <p>A Distance tool: 3HAC030662-001</p>
7	Refit the cover plate.	<p>Attachment screws: M10 quality 12.9 (4 pcs)</p>  <p>xx1300000554</p>

Concluding procedure

	Action	Note
1	Remove the lifting accessory.	
2	Re-calibrate the robot.	<p>Pendulum Calibration is described in <i>Operating manual - Calibration Pendulum</i>, enclosed with the calibration tools.</p> <p>Axis Calibration is described in Calibrating with Axis Calibration method on page 781.</p> <p>General calibration information is included in section Calibration on page 767.</p>
3	 <p>DANGER</p> <p>Make sure all safety requirements are met when performing the first test run.</p>	

4 Repair

4.6.1 Replacing spherical roller bearing, link ear

4.6 Frame and base

4.6.1 Replacing spherical roller bearing, link ear

Location of spherical roller bearing

The spherical roller bearing is located in the link ear of the balancing device.

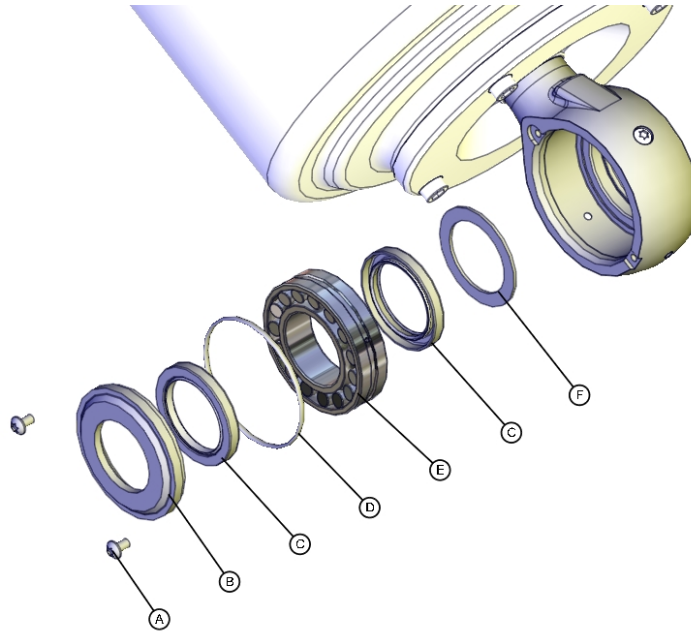

xx1300000773

A	Attachment screws M6x10 quality 8.8-A2F (2 pcs)
B	End cover
C	Radial sealing with dust lip, 50x68x8 (2 pcs)
D	O-ring 85x3
E	Spherical roller bearing
F	Washer

Summary of the replacement procedure

This is a brief summary of the replacement procedure, containing the major actions to be performed.

- 1 Unload the balancing device.
- 2 Replace the spherical roller bearing.
- 3 Restore the balancing device.

Continues on next page

4.6.1 Replacing spherical roller bearing, link ear
Continued

Spare part

Equipment	Article number	Note
Spherical roller bearing kit	3HAC045815-001	The maintenance kit contains: <ul style="list-style-type: none"> • End cover • Radial sealing with dust lip, 50x68x8 (2 pcs) • O-ring 85x3 • Spherical roller bearing • Washer

Consumables

Equipment, etc.	Article number	Note
Protection plug Only compatible with shaft 3HAC072597-001. See Shaft link ear versions on page 449 .	3HAC4836-26	Located at the front link ear of the balancing device.
VK cover, 28x7 Only compatible with shaft 3HAC044036-001. See Shaft link ear versions on page 449 .	3HAA2166-12	Located at the front link ear of the balancing device.
Grease	3HAA1001-294	Tribol GR 100-0 PD, 50 ml
Locking liquid	3HAB7116-1	Loctite 243

Required tools and equipment

Equipment, etc.	Article number	Note
Distance tool	3HAC030662-001	Only used to keep the balancing device in a locked position, after the balancing device springs has been unloaded with the help of the robot itself.  DANGER <i>Never</i> use this tool to unload or restore a balancing device!
Hydraulic press equipment, balancing device	3HAC074411-001	Used to unload or restore a balancing device.
Dismantle and mounting tool	3HAC028920-001	Used for removing and fitting shaft and bearings. User instructions are enclosed with the tool.
Hydraulic cylinder	3HAC11731-1	To be used with the press and puller tools. See technical specifications in the user instructions for the press equipment.
Hydraulic pump 80 MPa	3HAC13086-1	To be used with the press and puller tools. See technical specifications in the user instructions for the press equipment.

Continues on next page

4 Repair

4.6.1 Replacing spherical roller bearing, link ear

Continued

Equipment, etc.	Article number	Note
Lock screw, M16x120	-	Used to secure lower arm.
Lifting shackle	-	SA-10-8-NA1
Lifting accessory (chain)	3HAC15556-1	Lifting instruction 3HAC15880-2 enclosed.
Standard toolkit	-	Content is defined in section Standard toolkit on page 814 .

Unloading the balancing device

Use the correct tool for locking the balancing device springs in compressed position

Locking of the compressed balancing device springs in an unloaded position, can be done in two different ways using two different tools:



- Distance tool (compression of the balancing device springs is done with help of the robot itself)
- Hydraulic press equipment, balancing device (compression of the balancing device springs is done with the tool)

The situations when to use which tool are very different, see [When to use which tool on page 432](#).

The method described in this procedure, describes how to use the Distance tool (3HAC030662-001). The Distance tool can not be used to unload or restore the pressure of the balancing device spring unit! The Distance tool is only used to keep the balancing device springs in a locked position, after they have been unloaded with the help of the robot itself (as described in this procedure) and with the balancing device still being fitted on the robot.

When to use which tool

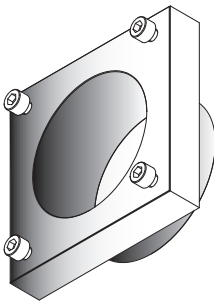
To unload or restore a balancing device which cannot be done with the help of the robot itself, the Hydraulic press equipment, balancing device (3HAC074411-001) must be used. See user instructions enclosed with the tool.

Illustration	Art. no.	Note
 <p>xx1400000726</p>	<p>3HAC030662-001 Distance tool</p>	<p>This tool is only used to keep the balancing device in a locked, already unloaded position. The balancing device springs has been unloaded with the help of the robot itself.</p> <p>Use this tool:</p> <ul style="list-style-type: none"> • to lock the balancing device springs in a compressed position (compressed by the robot) <p>See Unloading the balancing device springs with the robot and locking position with the Distance tool on page 434.</p> <p> DANGER</p> <p>Never use this tool to unload or restore a balancing device! This means that this tool can never be removed from a balancing device while the balancing device is removed from the robot.</p>

Continues on next page

4.6.1 Replacing spherical roller bearing, link ear
Continued

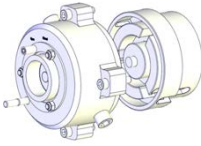
Illustration	Art. no.	Note
 <p>xx130000672</p>	<p>3HAC074411-001 Hydraulic press equipment, balancing device</p>	<p>This tool is used to unload or restore a balancing device. The balancing device can either be installed on a robot or not. This tool also locks the balancing device in an unloaded position after unloading.</p> <p>Use this tool:</p> <ul style="list-style-type: none"> to unload a balancing device without the help of the robot itself to unload a balancing device that needs to be restored after it has been removed from the robot to unload a balancing device not fitted on the robot, such as a spare part. <p>See Unloading the balancing device springs and locking position with the Hydraulic press equipment, balancing device on page 433</p>





DANGER

Never remove or fit the Distance tool on a balancing device which can not be unloaded by the robot. There is a severe risk of personal injury.

Unloading the balancing device springs and locking position with the Hydraulic press equipment, balancing device

Use this procedure to unload and lock the balancing device in unloaded position with the Hydraulic press equipment, balancing device (3HAC074411-001).

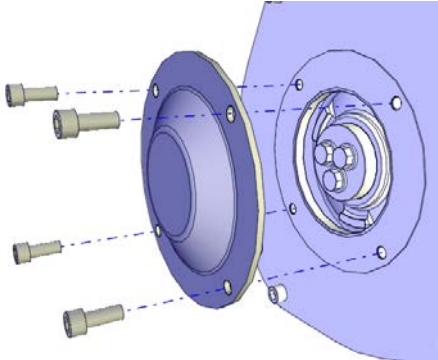

	Action	Note
1	Jog axis-2 to the calibration position.	
2	 <p>DANGER</p> <p>Turn off all:</p> <ul style="list-style-type: none"> electric power supply hydraulic pressure supply air pressure supply <p>to the robot, before entering the robot working area.</p>	
3	<p>Remove the cover plate on the back of the balancing device.</p>  <p>DANGER</p> <p>DO NOT remove any other screws than the rear cover attachment screws.</p>	 <p>xx130000554</p>

Continues on next page

4 Repair

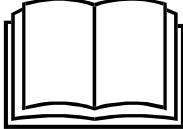

4.6.1 Replacing spherical roller bearing, link ear

Continued

	Action	Note
4	<p>Unload the balancing device with the <i>press equipment</i> in order to make the piston rod and front ear adjustable when pulling the shaft out.</p>  <p>xx0900000813</p> <p>Go to the user instructions enclosed with the press tool.</p> <p> DANGER</p> <p>Handling the tool incorrectly will cause serious injury.</p> <p>Read and follow enclosed user instructions for the tool.</p>	<p>Hydraulic press equipment, balancing device: 3HAC074411-001</p> <p>User instructions are enclosed with the tool.</p>





Unloading the balancing device springs with the robot and locking position with the Distance tool

Use this procedure to unload the balancing device with the help of the robot, and lock the balancing device springs in a compressed position, using the Distance tool (3HAC030662-001).

	Action	Note
1	<p> DANGER</p> <p>Do not use the Distance tool (3HAC030662-001) to unload or restore the pressure of the balancing device springs! This tool is only used to lock the spring unit in a compressed position, after axis-2 has been jogged to -30° or $+30^\circ$. Fitting and removal of the tool shall only be done with axis-2 in this position!</p> <p>To unload or restore a new balancing device or if the spring unit of the balancing device cannot be compressed by jogging the robot, only use the Hydraulic press equipment, balancing device (3HAC074411-001).</p>	
2	<p>Jog axis-2 to:</p> <ul style="list-style-type: none"> • -30° or $+30^\circ$ 	<p>This is done in order to compress the balancing device springs inside the balancing device before fitting the Distance tool.</p>
3	<p> DANGER</p> <p>Turn off all:</p> <ul style="list-style-type: none"> • electric power supply • hydraulic pressure supply • air pressure supply <p>to the robot, before entering the robot working area.</p>	

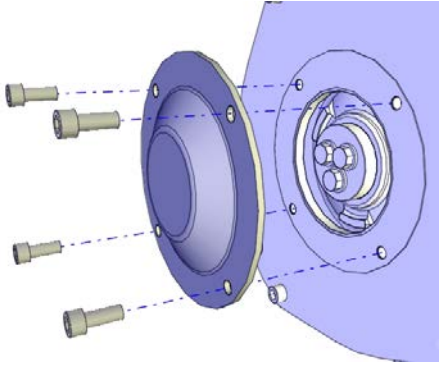
Continues on next page

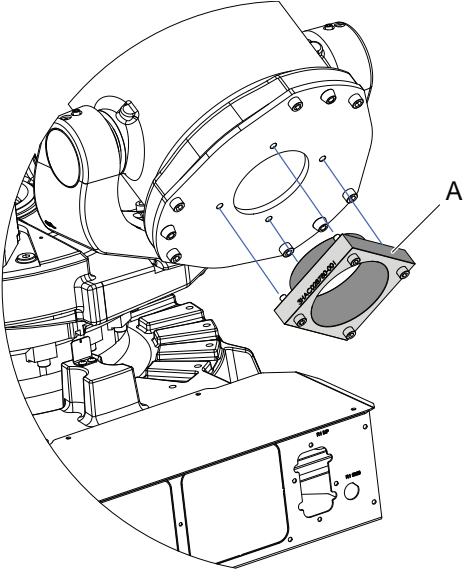
4.6.1 Replacing spherical roller bearing, link ear
Continued

	Action	Note
4	<p>Remove the cover plate on the back of the balancing device.</p> <p> DANGER</p> <p>DO NOT remove any other screws than the rear cover attachment screws.</p>	 <p>xx1300000554</p>
5	<p>Fit the Distance tool on the back of the balancing device using the four screws.</p> <p> DANGER</p> <p>Use caution when tightening the screws. The threads in the cover can be damaged if more tightening torque than 45 Nm is used, risking that the Distance tool is not properly fitted.</p>	<p>Tightening torque: 45 Nm Attachment screws: M10 quality 12.9 (4 pcs)</p>  <p>xx0800000480</p> <p>A Distance tool: 3HAC030662-001</p>
6	<p>Turn the power on temporary.</p>	
7	<p>Jog axis-2 to the calibration position. The balancing device is now unloaded.</p>	<p>This is done to compress the balancing device springs, making it possible to remove the front shaft of the balancing device.</p>
8	<p>Let the Distance tool stay fitted during the continued procedure.</p>	
9	<p> DANGER</p> <p>Turn off all:</p> <ul style="list-style-type: none"> • electric power supply • hydraulic pressure supply • air pressure supply <p>to the robot, before entering the robot working area.</p>	

Continues on next page

4 Repair



4.6.1 Replacing spherical roller bearing, link ear

Continued

Removing the spherical roller bearing

Use these procedures to remove the spherical roller bearing in the link ear.

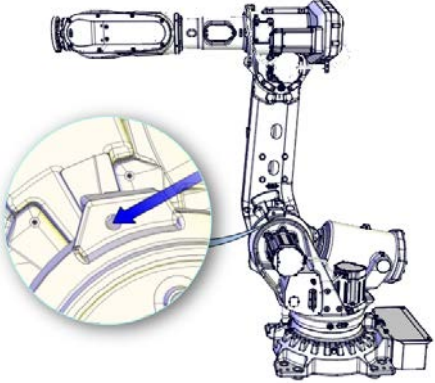
Preparations before removing the spherical roller bearing

	Action	Note
1	Verify that the balancing device is unloaded.	See Unloading the balancing device on page 432 .
2	Jog axis-2 to the calibration position (if not already in this position).	
3	Fit a lock screw through the hole for the lock screw in the frame and into the lower arm (or using a lifting accessory or similar). The lock screw is used to secure the weight of the lower arm, to avoid accidents or damage.	<p>Lock screw, M16x120</p>  <p>xx1200001116</p>
4	<p> DANGER</p> <p>Turn off all:</p> <ul style="list-style-type: none"> • electric power supply • hydraulic pressure supply • air pressure supply <p>to the robot, before entering the robot working area.</p>	
5	Remove any equipment, if fitted, on or close to the balancing device.	
6	<p> CAUTION</p> <p>The weight of the balancing device (excluding cradle) is</p> <p>140 kg (IRB 6700 -235/2.65, -205/2.80, -175/3.05, -150/3.20, -200/2.60, -155/2.85)</p> <p>185 kg (IRB 6700 -300/2.70, -245/3.00)</p> <p>All lifting accessories used must be sized accordingly.</p>	

Continues on next page

4.6.1 Replacing spherical roller bearing, link ear
Continued

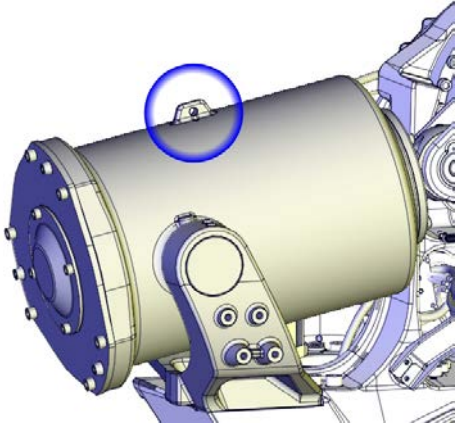
	Action	Note
7	Fit a lifting shackle to the balancing device.	Lifting shackle: SA-10-8-NA1  xx130000661
8	Fit the lifting accessory to the shackle and raise to unload the weight.	Lifting accessory (chain): 3HAC15556-1

Removing the shaft in the front (link ear)

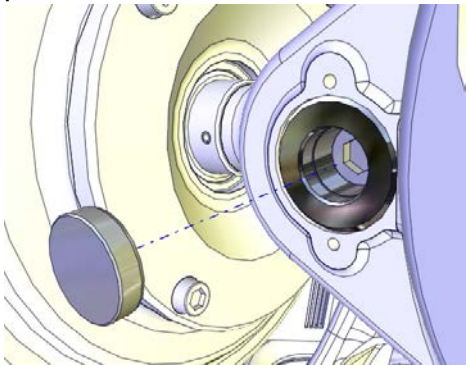
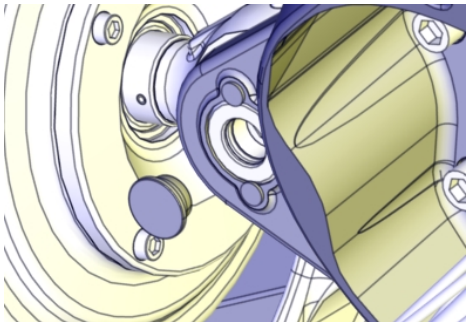

	Action	Note
1	Remove the protection plug or VK cover at the link ear (depends on shaft version).	It is possible to drive a screwdriver (or similar) through the VK cover, as close as possible to the center of the VK cover and pull it out.  xx1200001278  xx1900002311

Continues on next page

4 Repair

4.6.1 Replacing spherical roller bearing, link ear

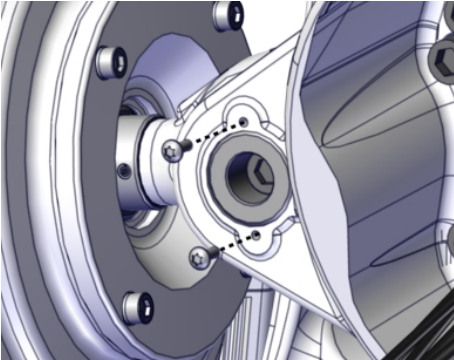
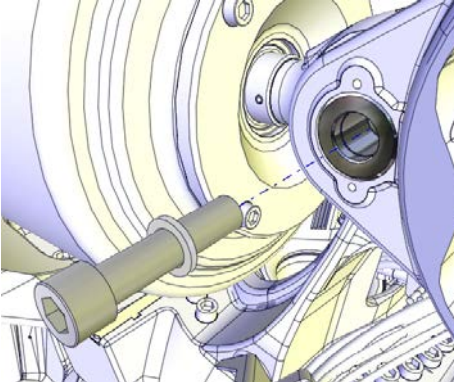
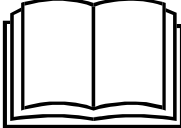
Continued

	Action	Note
2	Remove the two screws.	 <p>xx1900002146</p>
3	Unscrew the attachment screw and washer.	 <p>xx1200001279</p> <ul style="list-style-type: none"> • M16x70 quality steel 8.8-A3F
4	<p>Pull the shaft out using the dismantle and mounting tool, according to user instructions enclosed with the equipment.</p>  <p>xx0900000813</p> <p>Go to the user instructions enclosed with the press tool.</p> <p> DANGER</p> <p>Handling the tool incorrectly will cause serious injury.</p> <p>Read and follow enclosed user instructions for the tool.</p>	<p>Dismantle and mounting tool: 3HAC028920-001</p> <p>User instructions are enclosed with the tool.</p>

Continues on next page

4.6.1 Replacing spherical roller bearing, link ear
Continued

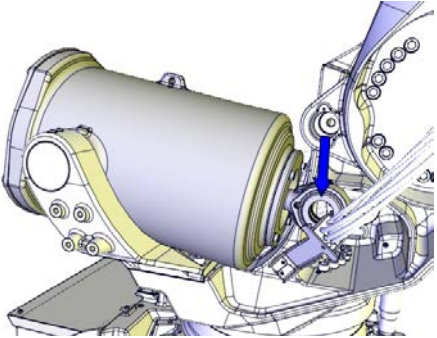
	Action	Note
5	Put down the balancing device and let it rest on the frame.	 <p>xx1200001281</p>

Removing the spherical roller bearing, link ear

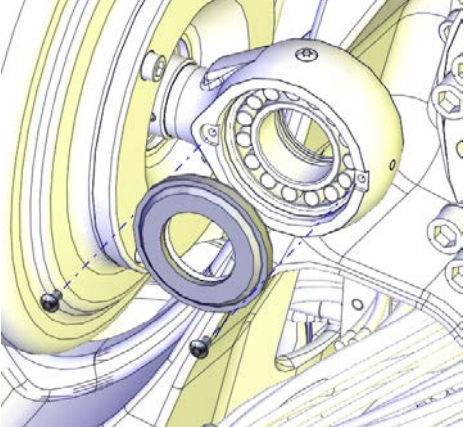
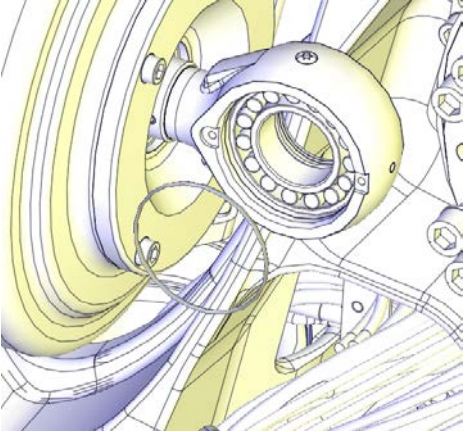

	Action	Note
1	Check that the link ear is in a position where it is possible to apply the dismantle and mounting tool. If not, adjust with the lifting accessory.	
2	Unscrew the attachment screws securing the end cover, remove end cover and radial sealing with a screwdriver.	 <p>xx1300000774</p>
3	Remove the o-ring.	 <p>xx1300000775</p>

Continues on next page

4 Repair

4.6.1 Replacing spherical roller bearing, link ear

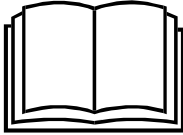
Continued

	Action	Note
4	<p>Pull the spherical roller bearing out together with the radial sealing and washer using the dismantle and mounting tool, according to user instructions enclosed with the equipment.</p>  <p>xx0900000813</p> <p>Go to the user instructions enclosed with the press tool.</p> <p> DANGER</p> <p>Handling the tool incorrectly will cause serious injury.</p> <p>Read and follow enclosed user instructions for the tool.</p>	<p>Dismantle and mounting tool: 3HAC028920-001</p> <p>User instructions are enclosed with the tool.</p>

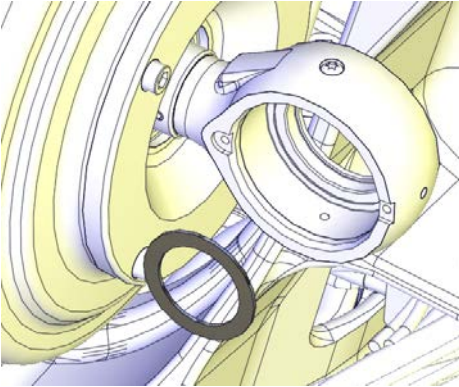

Refitting the spherical roller bearing

Refitting the spherical roller bearing, link ear

	Action	Note
1	Wipe clean all contact surfaces from residual grease.	
2	Refit the washer.	 <p>xx1300000778</p>

Continues on next page

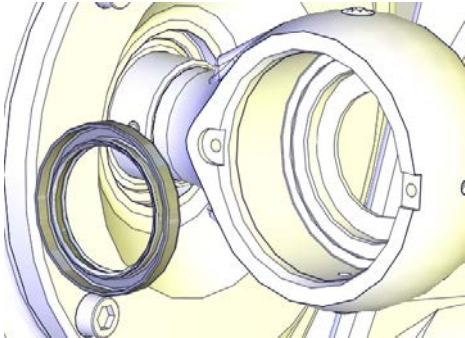
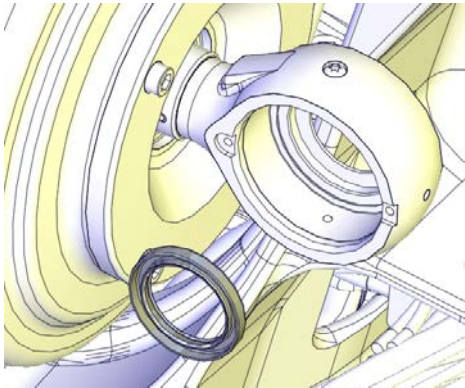
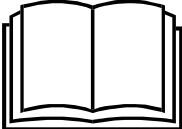
4.6.1 Replacing spherical roller bearing, link ear
Continued

	Action	Note
3	<p>Put the radial sealing on the Press tool J.</p> <p> Note</p> <p>Make sure that the sealing is turned according to the figure.</p>	<p>Press tool J included in tool set Dismantle and mounting tool</p>  <p>xx130000839</p>
4	<p>Use a plastic mallet or similar on the Press tool J and refit the radial sealing.</p>	 <p>xx130000777</p>
5	<p>Apply some grease on the surface for the bearing.</p>	
6	<p>Press in the spherical roller bearing using the dismantle and mounting tool, according to user instructions enclosed with the equipment.</p>  <p>xx0900000813</p> <p>Go to the user instructions enclosed with the press tool.</p> <p> DANGER</p> <p>Handling the tool incorrectly will cause serious injury.</p> <p>Read and follow enclosed user instructions for the tool.</p>	<p>Dismantle and mounting tool: 3HAC028920-001</p> <p>User instructions are enclosed with the tool.</p>

Continues on next page

4 Repair

4.6.1 Replacing spherical roller bearing, link ear

Continued

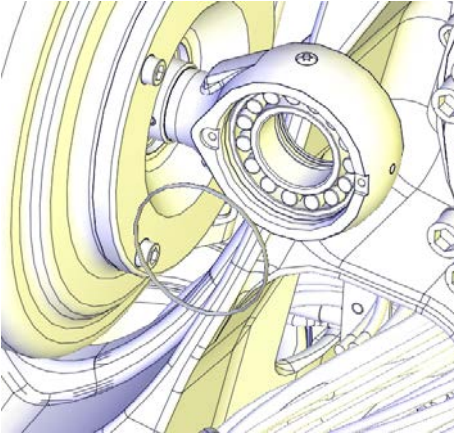
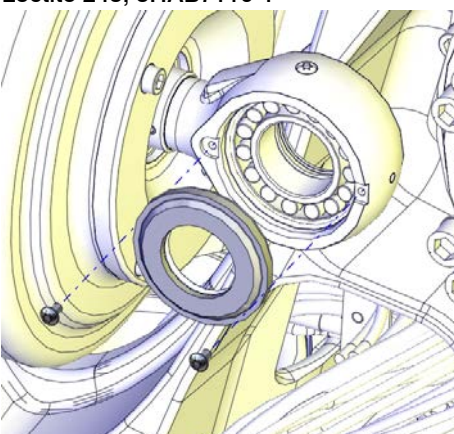

	Action	Note
7	Refit the o-ring.	 <p>xx130000775</p>
8	Apply Locking liquid on the screws and secure the end cover with the radial sealing ring.	<p>Loctite 243, 3HAB7116-1</p>  <p>xx130000774</p>

Refitting the front shaft of the balancing device

	Action	Note
1	Turn the power to the robot on temporarily.	
2	Use caution and jog the robot to the calibration position (if not already done).	
3	 <p>DANGER</p> <p>Turn off all:</p> <ul style="list-style-type: none"> • electric power supply • hydraulic pressure supply • air pressure supply <p>to the robot, before entering the robot working area.</p>	
4	Apply the lifting accessory to the balancing device (if not already done).	<p>Lifting shackle: SA-10-8-NA1</p> <p>Lifting accessory (chain): 3HAC15556-1</p>
5	Remove all residue of Loctite in the screw hole of the shaft.	

Continues on next page

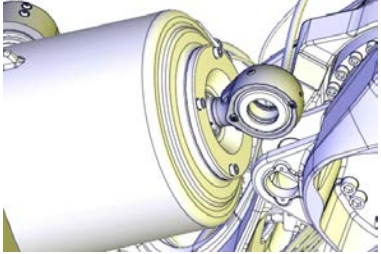
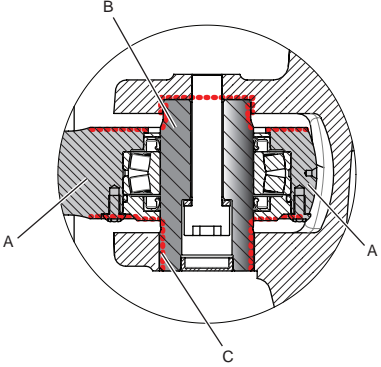
4.6.1 Replacing spherical roller bearing, link ear
Continued

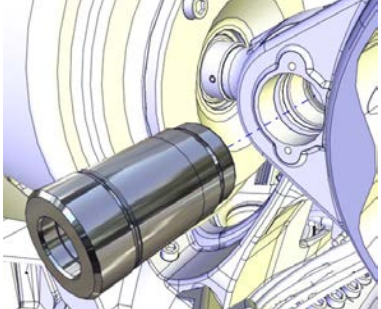

	Action	Note
6	Wipe all contact surfaces inside the recess clean from contamination.	
7	Align the balancing device link ear with the hole in the lower arm.  Note Verify that the link ear is correctly turned.	 xx1300000784
8	<i>Foundry Plus:</i> Apply Mercasol on the surfaces on the shaft and front ear.	 xx1400000368 A Front link ear B Shaft C Mercasol (red dotted lines)
9	Lubricate the shaft and place it to the front ear.  Note <i>Foundry Plus:</i> Do not lubricate surfaces where Mercasol is applied.	 xx1200001280

Continues on next page

4 Repair

4.6.1 Replacing spherical roller bearing, link ear

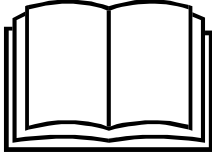
Continued

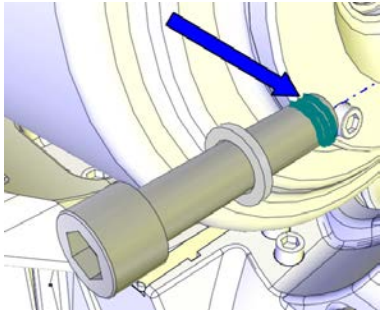
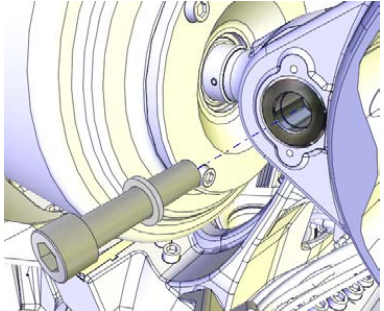
	Action	Note
10	<p>Press in the shaft using the dismantle and mounting tool, according to user instructions enclosed with the equipment.</p>  <p>xx0900000813</p> <p>Go to the user instructions enclosed with the press tool.</p> <p> DANGER</p> <p>Handling the tool incorrectly will cause serious injury. Read and follow enclosed user instructions for the tool.</p>	<p>Dismantle and mounting tool: 3HAC028920-001</p> <p>User instructions are enclosed with the tool.</p>
11	<p>Apply locking liquid (Loctite 2701) on the threads of the screw, first entering the threads in the frame.</p>	 <p>xx1300000782</p>
12	<p>Secure the shaft with screw and washer.</p>	<p>Tightening torque: 180 Nm</p>  <p>xx1200001279</p>

Continues on next page

4.6.1 Replacing spherical roller bearing, link ear
Continued

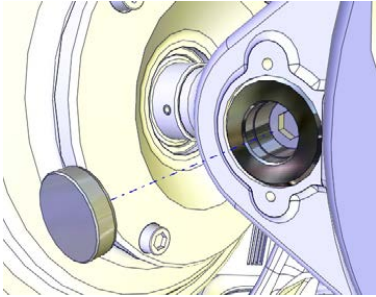
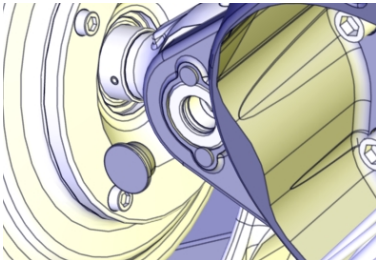
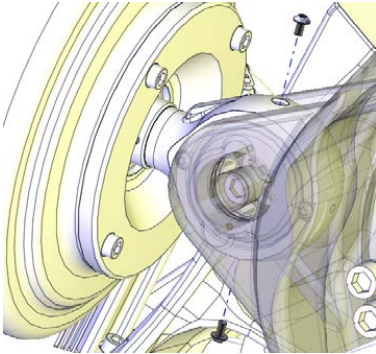
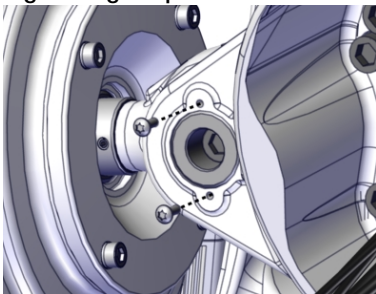
	Action	Note
13	Fit the protection plug or a new VK-cover (depends on shaft version).	 <p>xx1200001278</p>  <p>xx1900002311</p>
14	Unscrew both screws in link ear and fill the bearing with grease from the upper hole until the grease appears in the lower hole.	<p>Grease: 3HAA1001-294</p>  <p>xx1300000783</p>
15	Refit the two screws and wipe clean from residual grease.	<p>Tightening torque: 180 Nm</p>  <p>xx1900002146</p>

Concluded refitting of the front shaft

	Action	Note
1	Remove the lifting accessory from the balancing device.	

Continues on next page



4 Repair

4.6.1 Replacing spherical roller bearing, link ear

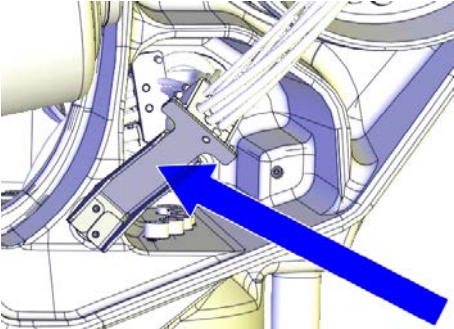
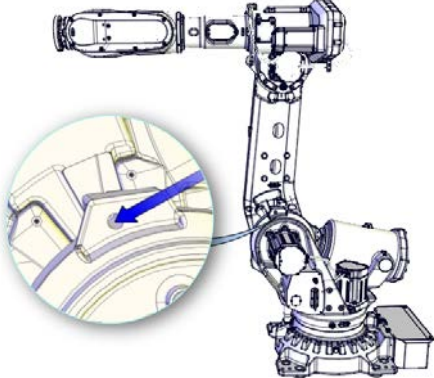
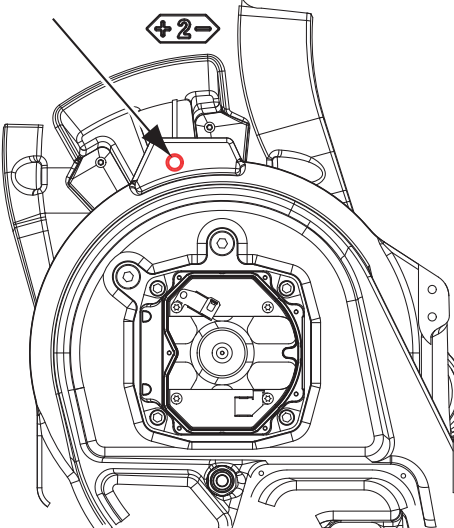
Continued

	Action	Note
2	Refit the cable bracket (if not already refitted).	 <p>xx1200001283</p>
3	Remove the locking screw (M16x120).	 <p>xx1200001116</p>
4	Foundry Plus: Apply Mercasol in the hole for the locking screw.	 <p>xx1400000372</p>

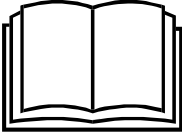
Continues on next page

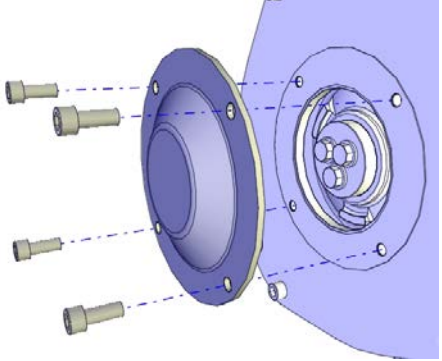
	Action	Note
5	<p>If the balancing device springs have been locked in unloaded position with the Distance tool:</p> <p>Jog axis-2 to:</p> <ul style="list-style-type: none"> • -30° or +30°. <p> DANGER</p> <p>Turn off all:</p> <ul style="list-style-type: none"> • electric power supply • hydraulic pressure supply • air pressure supply <p>to the robot, before entering the robot working area.</p> <p>Remove the Distance tool.</p>	
6	<p>If the balancing device springs have been unloaded and locked in unloaded position with the Hydraulic press equipment, balancing device:</p> <p>Restore the balancing device according to instructions for the <i>press equipment</i>.</p> <p></p> <p>xx0900000813</p> <p>Go to the user instructions enclosed with the press tool.</p> <p> DANGER</p> <p>Handling the tool incorrectly will cause serious injury.</p> <p>Read and follow enclosed user instructions for the tool.</p>	<p>User instructions are enclosed with the tool.</p>
7	<p>Apply flange sealant and refit the cover plate on the back of the balancing device.</p>	<p>Screws: M10 quality 12.9. Tightening torque: 50 Nm. Flange sealant for conical fittings: Loctite 577.</p> <p></p> <p>xx1300000554</p>

4 Repair

4.6.2 Replacing the balancing device

4.6.2 Replacing the balancing device

Location of the balancing device

The balancing device is located as shown in the figure.

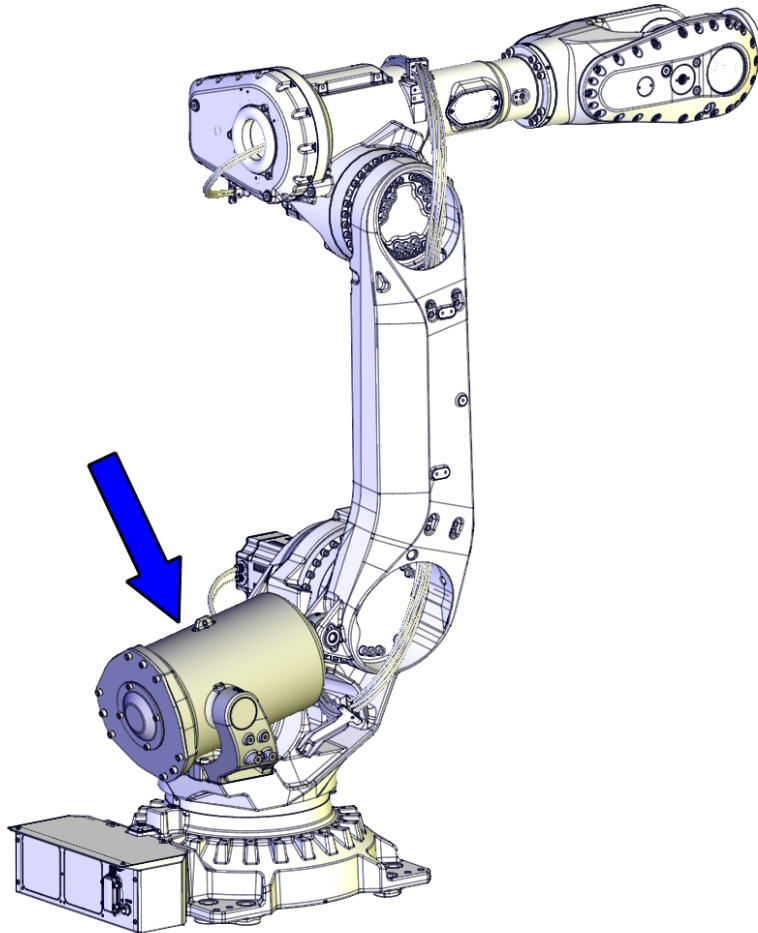

xx130000660

Summary of the replacement procedure

This is a brief summary of the replacement procedure, containing the major actions to be performed.

- 1 Unload the balancing device.
- 2 Replace the balancing device.

Spare part

Spare parts	Spare part number	Note
Balancing device	See <i>Product manual, spare parts - IRB 6700/IRB 6700Inv.</i> <i>Product manual, spare parts - IRB 6790</i>	

Continues on next page

Consumables

Equipment, etc.	Article number	Note
Grease	3HAA1001-294	Tribol GR 100-0 PD
Protection plug Only compatible with shaft 3HAC072597-001. See Shaft link ear versions on page 449 .	3HAC4836-26	Located at the front link ear of the balancing device.
VK cover, 28x7 Only compatible with shaft 3HAC044036-001. See Shaft link ear versions on page 449 .	3HAA2166-12	Located at the front link ear of the balancing device.
VK cover, 90x12	3HAA2166-28	Located at the cradle of the balancing device. 2 pcs required.
Locking liquid	3HAB7116-1	Loctite 243
Rust preventive	3HAC034903-001	Mercasol 3110 Waxcoat. Recommended drying time is 24h.
Flange sealant for conical fittings	-	Loctite 577

Shaft link ear versions



Required tools and equipment

Equipment, etc.	Article number	Note
Lock screw, M16x120	-	Used to secure lower arm.
Threaded bar, M16x340	-	
Anvil	3HAC047273-001	Included in the tool kit Dismantle and mounting tool (3HAC028920-001).
Hydraulic press equipment, balancing device	3HAC074411-001	Used to unload or restore a balancing device.
Dismantle and mounting tool	3HAC028920-001	Used for removing and fitting shaft and bearings. User instructions are enclosed with the tool.

Continues on next page

4 Repair

4.6.2 Replacing the balancing device



Continued

Equipment, etc.	Article number	Note
Hydraulic pump 80 MPa	3HAC13086-1	To be used with the press and puller tools. See technical specifications in the user instructions for the press equipment.
Hydraulic cylinder	3HAC11731-1	To be used with the press and puller tools. See technical specifications in the user instructions for the press equipment.
Lifting accessory (chain)	3HAC15556-1	Lifting instruction 3HAC15880-2 enclosed.
Lifting shackle	-	SA-10-8-NA1
Standard toolkit	-	Content is defined in section Standard toolkit on page 814 .



Unloading the balancing device

Unloading the balancing device springs and locking position with the Hydraulic press equipment, balancing device

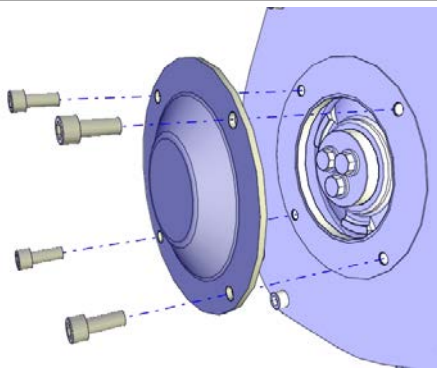
Use this procedure to unload and lock the balancing device in unloaded position with the Hydraulic press equipment, balancing device (3HAC074411-001).

	Action	Note
1	Jog axis-2 to the calibration position.	
2	 DANGER Turn off all: <ul style="list-style-type: none"> • electric power supply • hydraulic pressure supply • air pressure supply to the robot, before entering the robot working area.	
3	Remove the cover plate on the back of the balancing device.  DANGER DO NOT remove any other screws than the rear cover attachment screws.	 <small>xx1300000554</small>

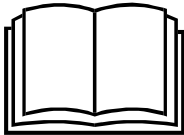

Continues on next page

	Action	Note
4	<p>Unload the balancing device with the <i>press equipment</i> in order to make the piston rod and front ear adjustable when pulling the shaft out.</p>  <p>xx0900000813</p> <p>Go to the user instructions enclosed with the press tool.</p> <p> DANGER</p> <p>Handling the tool incorrectly will cause serious injury.</p> <p>Read and follow enclosed user instructions for the tool.</p>	<p>Hydraulic press equipment, balancing device: 3HAC074411-001</p> <p>User instructions are enclosed with the tool.</p>

Removing the balancing device

Use these procedures to remove the balancing device.

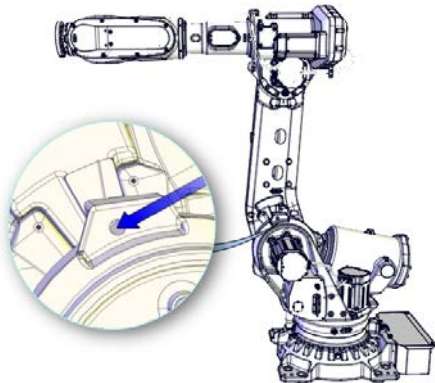
Preparations before removing the balancing device

	Action	Note
1	<p>Verify that the balancing device is unloaded.</p>	<p>See Unloading the balancing device on page 450.</p>
2	<p>Jog axis-2 to the calibration position (if not already in this position).</p>	
3	<p>Fit a locking screw M16x120 through the hole for the lock screw in the frame and into the lower arm (or using a lifting accessory or similar).</p> <p>The lock screw is used to secure the weight of the lower arm, in order to avoid accidents or damage.</p>	 <p>xx1200001116</p>
4	<p> DANGER</p> <p>Turn off all:</p> <ul style="list-style-type: none"> • electric power supply • hydraulic pressure supply • air pressure supply <p>to the robot, before entering the robot working area.</p>	

Continues on next page

4 Repair

4.6.2 Replacing the balancing device

Continued

	Action	Note
5	Remove any equipment, if fitted, on or close to the balancing device.	

Attaching lifting accessory to the balancing device

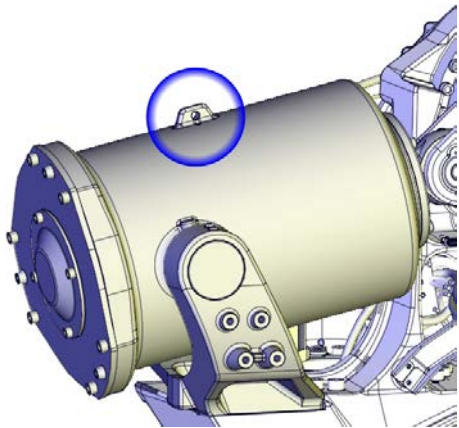
	Action	Note
1	 CAUTION The weight of the balancing device (excluding cradle) is 140 kg (IRB 6700 -235/2.65, -205/2.80, -175/3.05, -150/3.20, -200/2.60, -155/2.85) 185 kg (IRB 6700 -300/2.70, -245/3.00) All lifting accessories used must be sized accordingly.	
2	Fit a lifting shackle to the balancing device.	Lifting shackle: SA-10-8-NA1  xx130000661
3	Fit the lifting accessory to the shackle and raise to unload the weight.	Lifting accessory (chain): 3HAC15556-1

Continues on next page

Removing the rear shafts

Perform this procedure on both sides.

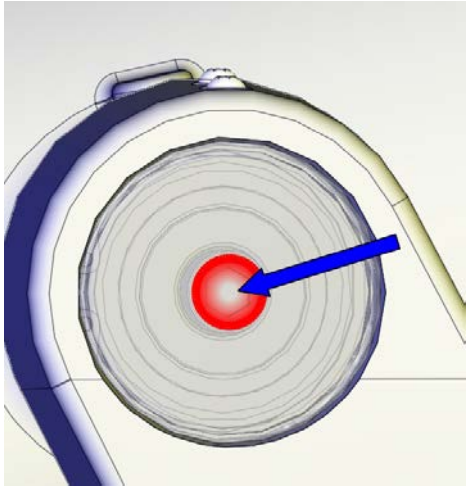
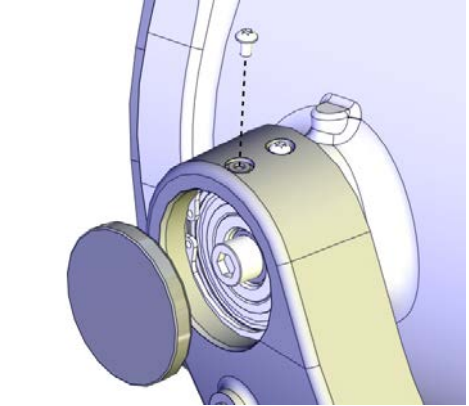

	Action	Note
1	<p>Remove the both VK covers using one of the recommended methods:</p> <ul style="list-style-type: none"> • Drive a screwdriver (or similar) through the VK cover, as close as possible to the center of the VK cover, and bend out the cover. If not making a hole in the center of the VK cover, there is a risk of damaging the bearing inside. The damaged VK cover must be replaced with a new. • Remove the protection screw from the vent hole and use air pressure through the hole to blow out the cover. The cover can be reused if not damaged. 	<p>VK cover, 90x12: 3HAA2166-28 Position for screwdriver:</p>  <p>xx130000662</p> <p>Vent hole for air pressure:</p>  <p>xx1700002189</p>
2	<p>Wipe off any residual grease inside the recess.</p>	

Continues on next page

4 Repair

4.6.2 Replacing the balancing device

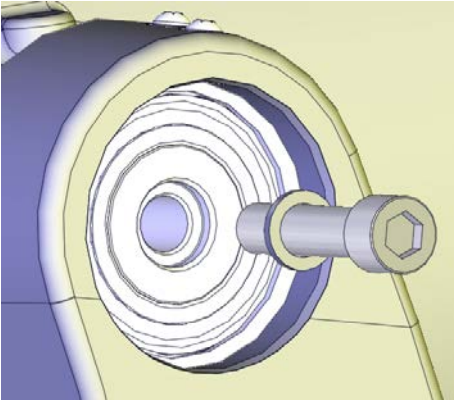
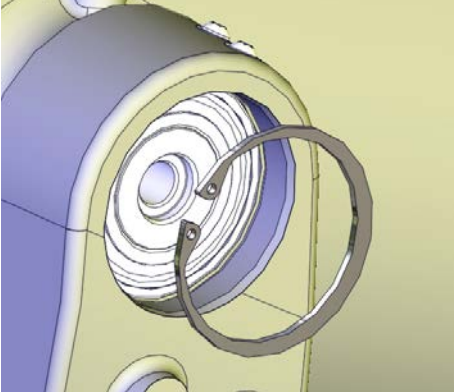
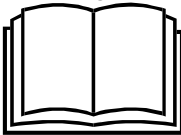
Continued

	Action	Note
3	Unscrew the attachment screws on each shaft.	 <p>xx1300000663</p> <p>M16x70 quality steel 12.9 Gleitmo 603</p>
4	Remove retaining ring, bore on one side.	 <p>xx1300000664</p>
5	Use the removal tool and pull the shaft out a few millimeters, just long enough for the balancing device to go free.  <p>xx0900000813</p> <p>Go to the user instructions enclosed with the press tool.</p> <p> DANGER</p> <p>Handling the tool incorrectly will cause serious injury.</p> <p>Read and follow enclosed user instructions for the tool.</p>	<p>Dismantle and mounting tool: 3HAC028920-001</p> <p>User instructions are enclosed with the tool.</p>

Continues on next page

Removing the shaft in the front (link ear)

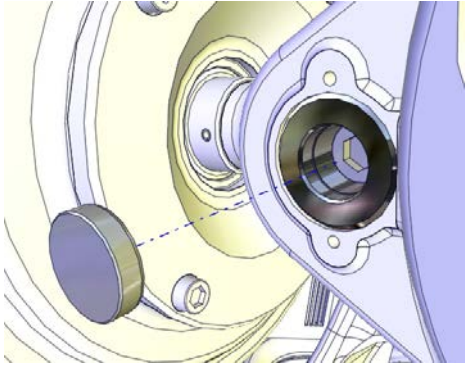
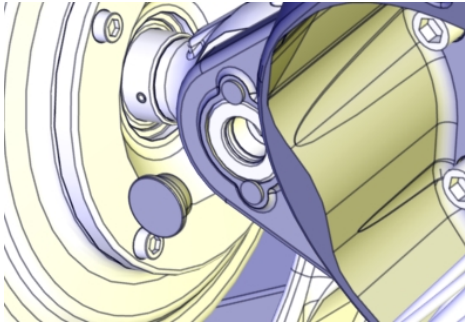
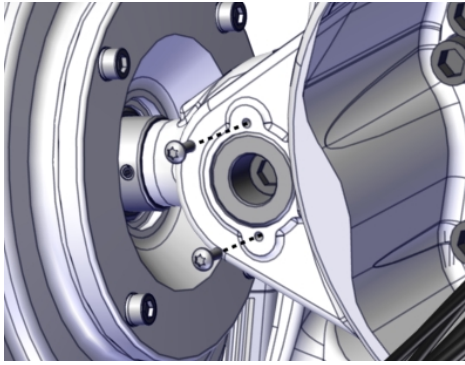

	Action	Note
1	Remove the protection plug or VK cover at the link ear (depends on shaft version).	<p>It is possible to drive a screwdriver (or similar) through the VK cover, as close as possible to the center of the VK cover and pull it out.</p>  <p>xx1200001278</p>  <p>xx1900002311</p>
2	Remove the two screws.	 <p>xx1900002146</p>

Continues on next page

4 Repair

4.6.2 Replacing the balancing device

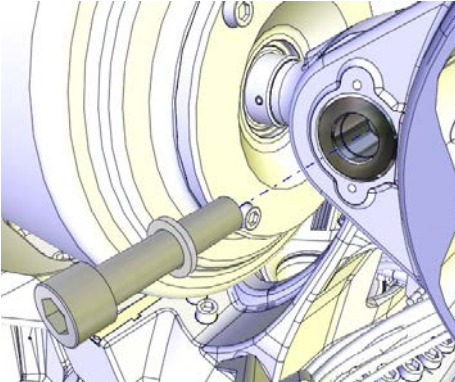
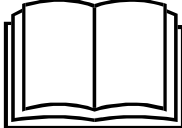
Continued

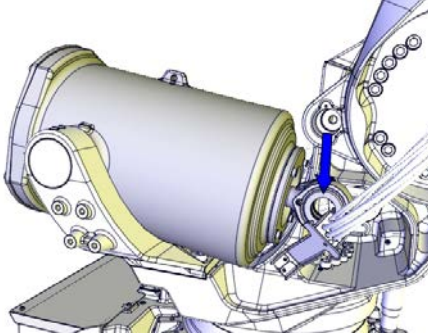
	Action	Note
3	Unscrew the attachment screw and washer.	 <p>xx1200001279</p> <ul style="list-style-type: none"> • M16x70 quality steel 8.8-A3F
4	Pull the shaft out using the dismantle and mounting tool, according to user instructions enclosed with the equipment.  <p>xx0900000813</p> <p>Go to the user instructions enclosed with the press tool.</p> <p> DANGER</p> <p>Handling the tool incorrectly will cause serious injury. Read and follow enclosed user instructions for the tool.</p>	Dismantle and mounting tool: 3HAC028920-001 User instructions are enclosed with the tool.
5	Put down the balancing device and let it rest on the frame.	 <p>xx1200001281</p>

Concluding procedure

	Action	Note
1	Remove the balancing device.	

Continues on next page

	Action	Note
2	<p>If the same balancing device shall be refitted, the Distance tool 3HAC030662-001 must stay fitted during the time the balancing device is removed from the robot.</p> <p> DANGER</p> <p>The distance tool shall, under no circumstance, be fitted on or be removed from a balancing device that not is fitted to the robot!</p> <p>Fitting and removing this tool can only be done in a safe way with axis-2 in -30° or +30° position and with the balancing device fitted to the robot.</p>	

Refitting the balancing device

Use this procedure to refit the balancing device.

Attaching lifting accessory to the balancing device

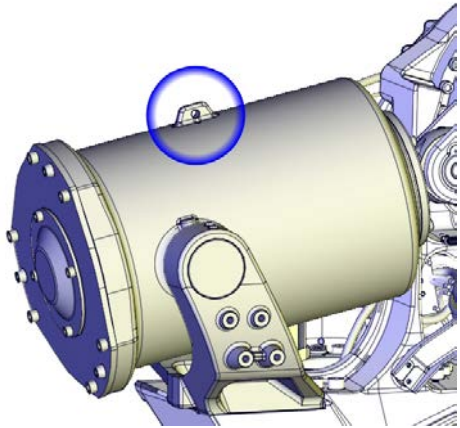
	Action	Note
1	<p> CAUTION</p> <p>The weight of the balancing device (excluding cradle) is</p> <p>140 kg (IRB 6700 -235/2.65, -205/2.80, -175/3.05, -150/3.20, -200/2.60, -155/2.85)</p> <p>185 kg (IRB 6700 -300/2.70, -245/3.00)</p> <p>All lifting accessories used must be sized accordingly.</p>	
2	Fit a lifting shackle to the balancing device.	<p>Lifting shackle: SA-10-8-NA1</p>  <p>xx130000661</p>
3	Fit the lifting accessory to the shackle and raise to unload the weight.	Lifting accessory (chain): 3HAC15556-1

Continues on next page



4 Repair

4.6.2 Replacing the balancing device

Continued

Unloading a new spare part, balancing device

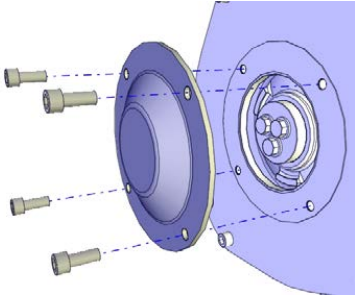
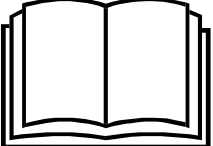
Before a new spare part balancing device is fitted, the springs must be unloaded using the Hydraulic press equipment, balancing device (3HAC074411-001).



	Action	Note
1	<p>Remove the cover plate on the back of the balancing device.</p> <p> DANGER</p> <p>DO NOT remove any other screws than the rear cover attachment screws.</p>	 <p>xx1300000554</p>
2	<p>Unload the balancing device with the <i>press equipment</i> in order to make the piston rod and front ear adjustable when pulling the shaft out.</p>  <p>xx0900000813</p> <p>Go to the user instructions enclosed with the press tool.</p> <p> DANGER</p> <p>Handling the tool incorrectly will cause serious injury.</p> <p>Read and follow enclosed user instructions for the tool.</p>	<p>Hydraulic press equipment, balancing device: 3HAC074411-001</p> <p>User instructions are enclosed with the tool.</p>

Refitting the rear shafts

Perform this procedure on both sides.

	Action	Note
1	<p> DANGER</p> <p>Turn off all:</p> <ul style="list-style-type: none"> • electric power supply • hydraulic pressure supply • air pressure supply <p>to the robot, before entering the robot working area.</p>	
2	<p>Lift the balancing device into position in the cradle.</p>	

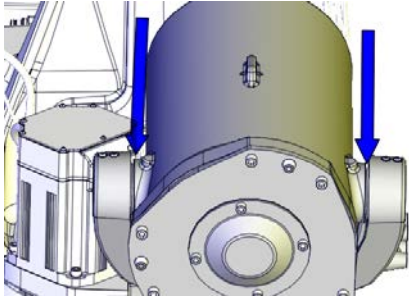
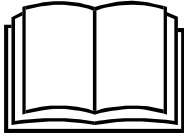
Continues on next page

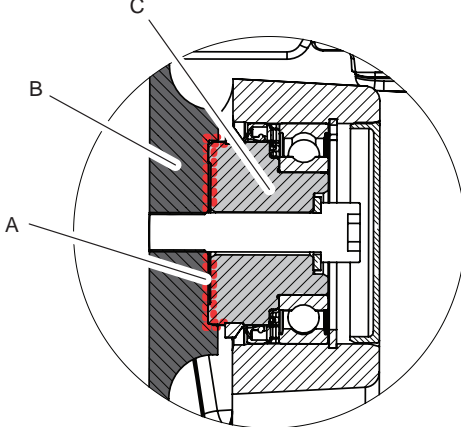
	Action	Note
3	<p>Apply a big screwdriver between the cradle and the balancing device, as shown in the figure when the shafts are refitted.</p>	 <p>xx130000838</p>
4	<p>Apply the refitting tool and press the shafts into position one at a time.</p>  <p>xx090000813</p> <p>Go to the user instructions enclosed with the press tool.</p> <p> DANGER</p> <p>Handling the tool incorrectly will cause serious injury.</p> <p>Read and follow enclosed user instructions for the tool.</p>	<p>Dismantle and mounting tool: 3HAC028920-001</p> <p>User instructions are enclosed with the tool.</p>
5	<p><i>Foundry Plus:</i></p> <p>Apply Mercasol on matching surfaces on the axis and balancing device. See the figure!</p>	 <p>xx140000367</p> <p>A Mercasol (red dotted lines) B Balancing device C Shaft</p>

Continues on next page



4 Repair

4.6.2 Replacing the balancing device

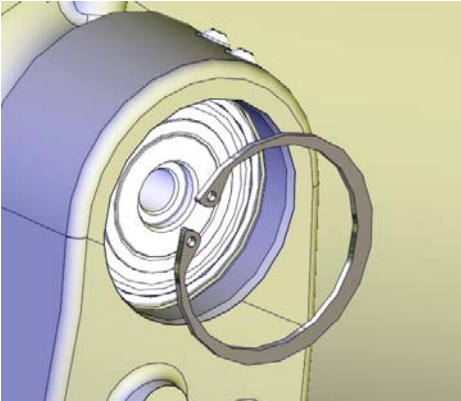
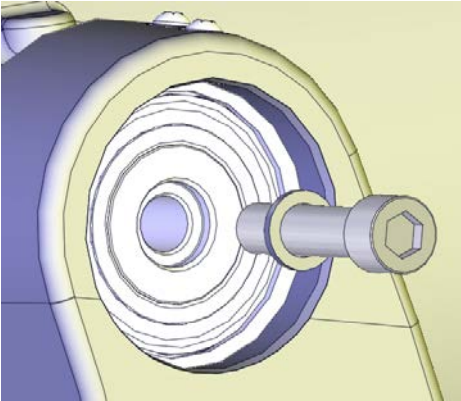
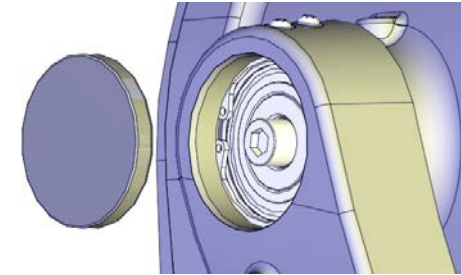
Continued

	Action	Note
6	Fit the retaining ring.	 <p>xx130000664</p>
7	Apply Loctite 243 on the screws and secure the shafts on both sides.	<p>M16x70 quality steel 12.9 Gleitmo 603 Tightening torque: 280 Nm</p>  <p>xx130000663</p>
8	Refit new VK covers.	<p>VK cover, 90x12, 3HAA2166-28</p>  <p>xx130000837</p>

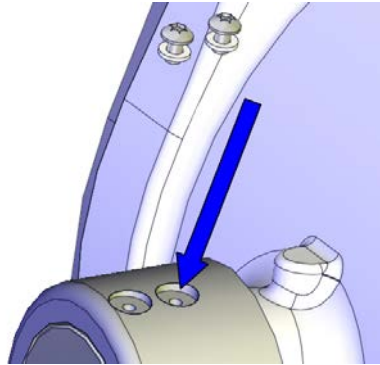
Continues on next page

	Action	Note
9	Unscrew both screws in the cradle and fill the bearing with grease from the inner hole (see figure) until grease appears in the outer hole.	Grease: 3HAA1001-294  <small>xx1300000832</small>
10	Refit the screws.	
11	Wipe clean from residual grease.	
12	 DANGER Make sure all safety requirements are met when performing the first test run.	

Refitting the front shaft of the balancing device



	Action	Note
1	Turn the power to the robot on temporarily.	
2	Use caution and jog the robot to the calibration position (if not already done).	
3	 DANGER Turn off all: <ul style="list-style-type: none"> • electric power supply • hydraulic pressure supply • air pressure supply to the robot, before entering the robot working area.	
4	Apply the lifting accessory to the balancing device (if not already done).	Lifting shackle: SA-10-8-NA1 Lifting accessory (chain): 3HAC15556-1
5	Remove all residue of Loctite in the screw hole of the shaft.	
6	Wipe all contact surfaces inside the recess clean from contamination.	

Continues on next page

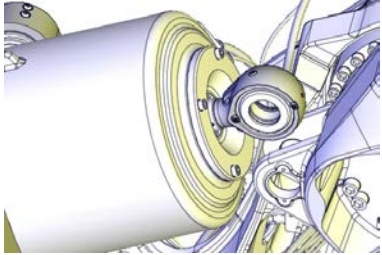
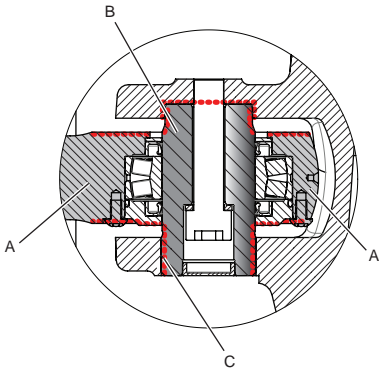

4 Repair

4.6.2 Replacing the balancing device

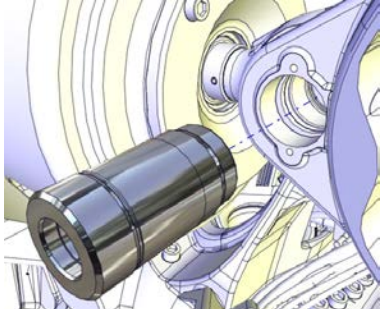
Continued

	Action	Note
7	<p>Align the balancing device link ear with the hole in the lower arm.</p> <p> Note</p> <p>Verify that the link ear is correctly turned.</p>	 <p>xx1300000784</p>
8	<p><i>Foundry Plus:</i></p> <p>Apply Mercasol on the surfaces on the shaft and front ear.</p>	 <p>xx1400000368</p> <p>A Front link ear B Shaft C Mercasol (red dotted lines)</p>
9	<p>Lubricate the shaft and place it to the front ear.</p> <p> Note</p> <p><i>Foundry Plus:</i></p> <p>Do not lubricate surfaces where Mercasol is applied.</p>	 <p>xx1200001280</p>

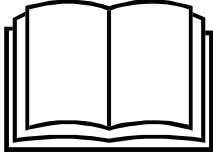
Continues on next page

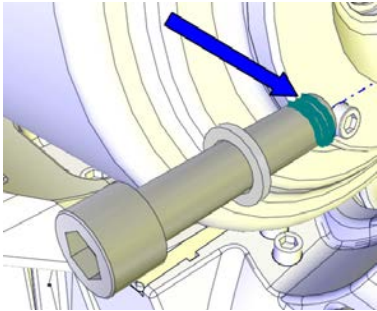
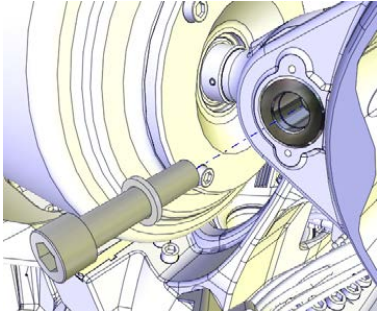
	Action	Note
10	<p>Press in the shaft using the dismantle and mounting tool, according to user instructions enclosed with the equipment.</p>  <p>xx0900000813</p> <p>Go to the user instructions enclosed with the press tool.</p> <p> DANGER</p> <p>Handling the tool incorrectly will cause serious injury.</p> <p>Read and follow enclosed user instructions for the tool.</p>	<p>Dismantle and mounting tool: 3HAC028920-001</p> <p>User instructions are enclosed with the tool.</p>
11	<p>Apply locking liquid (Loctite 2701) on the threads of the screw, first entering the threads in the frame.</p>	 <p>xx1300000782</p>
12	<p>Secure the shaft with screw and washer.</p>	<p>Tightening torque: 180 Nm</p>  <p>xx1200001279</p>

Continues on next page

4 Repair

4.6.2 Replacing the balancing device

Continued

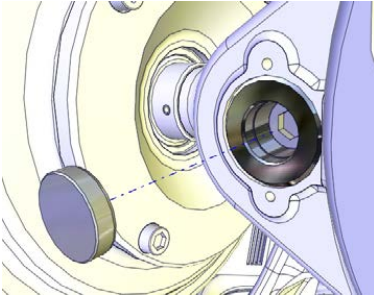
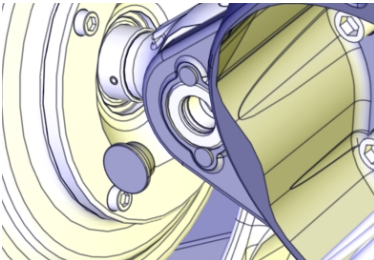
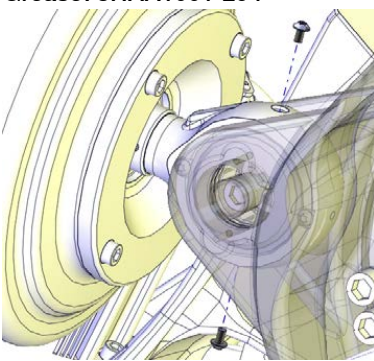
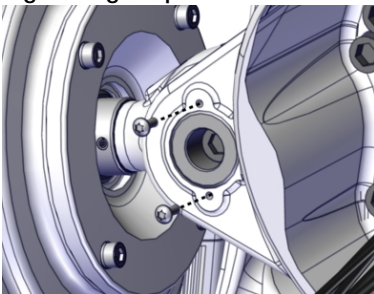
	Action	Note
13	Fit the protection plug or a new VK-cover (depends on shaft version).	 <p>xx1200001278</p>  <p>xx1900002311</p>
14	Unscrew both screws in link ear and fill the bearing with grease from the upper hole until the grease appears in the lower hole.	<p>Grease: 3HAA1001-294</p>  <p>xx1300000783</p>
15	Refit the two screws and wipe clean from residual grease.	<p>Tightening torque: 180 Nm</p>  <p>xx1900002146</p>

Concluded refitting of the front shaft

	Action	Note
1	Remove the lifting accessory from the balancing device.	

Continues on next page

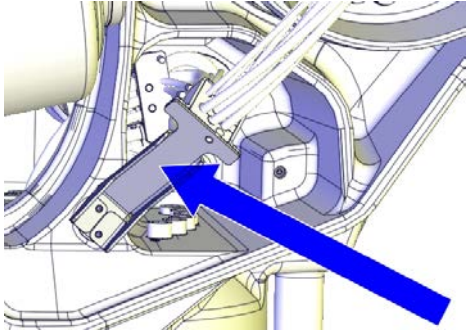
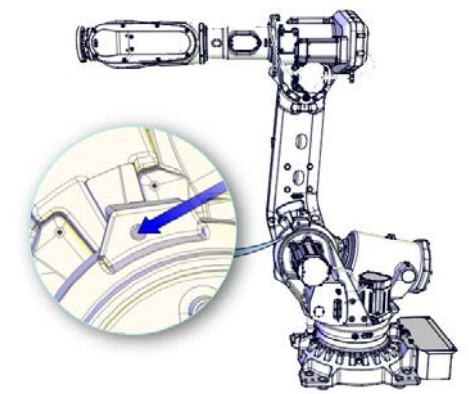
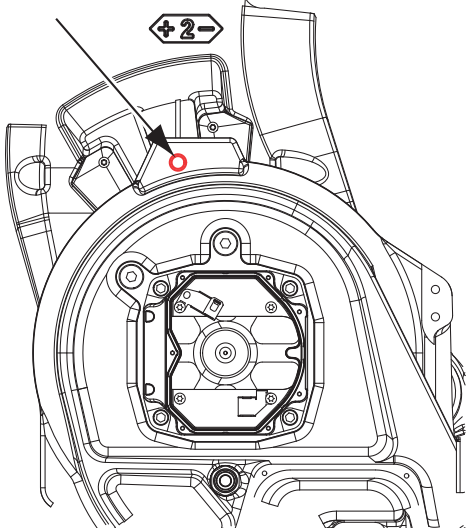

	Action	Note
2	Refit the cable bracket (if not already refitted).	 <p>xx1200001283</p>
3	Remove the locking screw (M16x120).	 <p>xx1200001116</p>
4	<p><i>Foundry Plus:</i> Apply Mercasol in the hole for the locking screw.</p>	 <p>xx1400000372</p>

Continues on next page

4 Repair

4.6.2 Replacing the balancing device

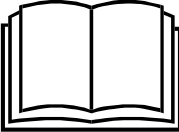
Continued

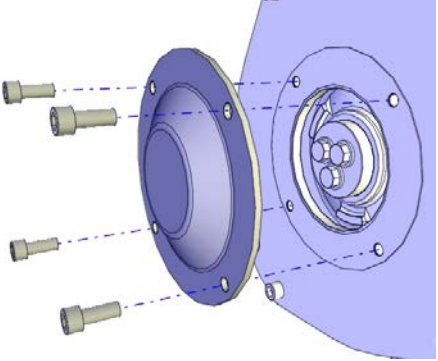
	Action	Note
5	<p>If the balancing device springs have been locked in unloaded position with the Distance tool:</p> <p>Jog axis-2 to:</p> <ul style="list-style-type: none"> • -30° or +30°. <p> DANGER</p> <p>Turn off all:</p> <ul style="list-style-type: none"> • electric power supply • hydraulic pressure supply • air pressure supply <p>to the robot, before entering the robot working area.</p> <p>Remove the Distance tool.</p>	
6	<p>If the balancing device springs have been unloaded and locked in unloaded position with the Hydraulic press equipment, balancing device:</p> <p>Restore the balancing device according to instructions for the <i>press equipment</i>.</p> <p></p> <p>xx0900000813</p> <p>Go to the user instructions enclosed with the press tool.</p> <p> DANGER</p> <p>Handling the tool incorrectly will cause serious injury.</p> <p>Read and follow enclosed user instructions for the tool.</p>	<p>User instructions are enclosed with the tool.</p>
7	<p>Apply flange sealant and refit the cover plate on the back of the balancing device.</p>	<p>Screws: M10 quality 12.9. Tightening torque: 50 Nm. Flange sealant for conical fittings: Loctite 577.</p> <p></p> <p>xx1300000554</p>

4.6.3 Replacing the rear bearings on the balancing device

Location of rear bearings, balancing device

The rear bearings of the balancing device are located in the cradle, one on each side.

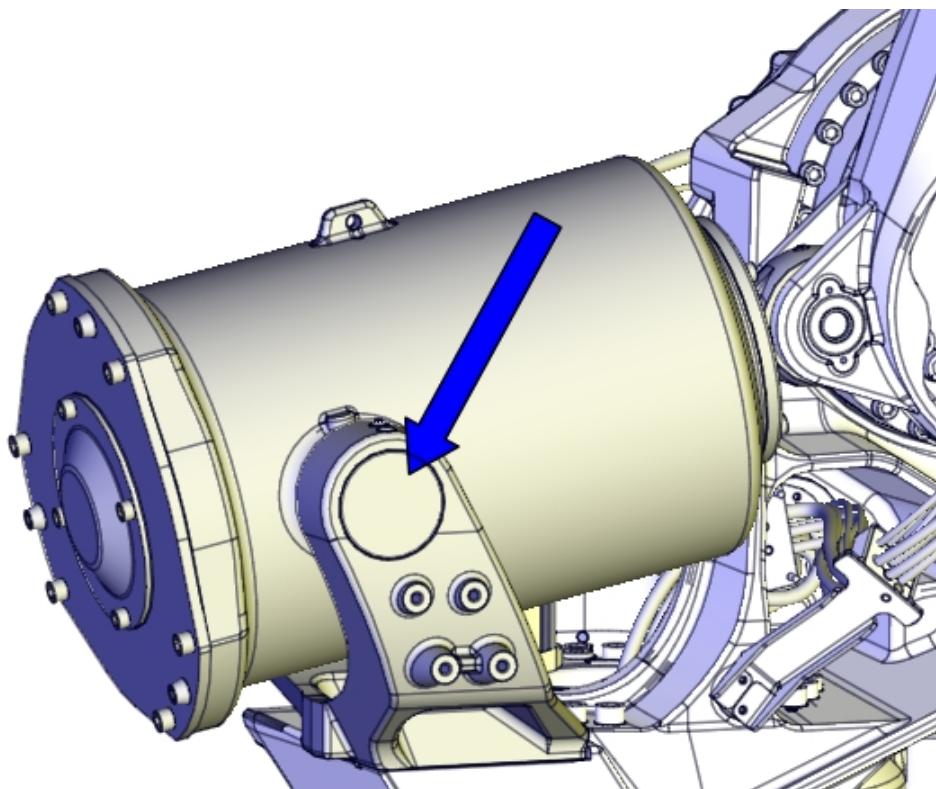

xx130000785

Spare parts

Equipment	Article number	Note
Maintenance set cradle	3HAC045822-001	The maintenance kit contains all necessary parts to replace the bearing, including VK covers. VK covers can be ordered separately, 3HAA2166-28 (2 pcs).

Consumables

Equipment	Article number	Note
VK cover, 90x12	3HAA2166-28	Located at the cradle of the balancing device. 2 pcs required.
Locking liquid	3HAB7116-1	Loctite 243
Grease	3HAC042536-001	Shell Gadus S2

Continues on next page

4 Repair

4.6.3 Replacing the rear bearings on the balancing device

Continued

Required tools and equipment

Equipment	Article number	Note
Distance tool	3HAC030662-001	Only used to keep the balancing device in a locked position, after the balancing device springs has been unloaded with the help of the robot itself.  DANGER <i>Never</i> use this tool to unload or restore a balancing device!
Lock screw, M16x120	-	Used to secure lower arm.
Lifting shackle	-	SA-10-8-NA1
Lifting accessory (chain)	3HAC15556-1	Lifting instruction 3HAC15880-2 enclosed.
Threaded bar, M16x340	-	
Dismantle and mounting tool	3HAC028920-001	Used for removing and fitting shaft and bearings. User instructions are enclosed with the tool.
Standard toolkit	-	Content is defined in section Standard toolkit on page 814 .

Unloading the balancing device

Unloading the balancing device springs with the robot and locking position with the Distance tool





Use this procedure to unload the balancing device with the help of the robot, and lock the balancing device springs in a compressed position, using the Distance tool (3HAC030662-001).

Action	Note
1  DANGER Do not use the Distance tool (3HAC030662-001) to unload or restore the pressure of the balancing device springs! This tool is only used to lock the spring unit in a compressed position, after axis-2 has been jogged to -30° or $+30^\circ$. Fitting and removal of the tool shall only be done with axis-2 in this position! To unload or restore a new balancing device or if the spring unit of the balancing device cannot be compressed by jogging the robot, only use the Hydraulic press equipment, balancing device (3HAC074411-001).	
2 Jog axis-2 to: • -30° or $+30^\circ$	This is done in order to compress the balancing device springs inside the balancing device before fitting the Distance tool.

Continues on next page

4.6.3 Replacing the rear bearings on the balancing device

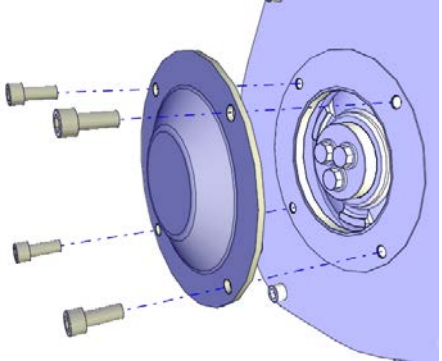
Continued

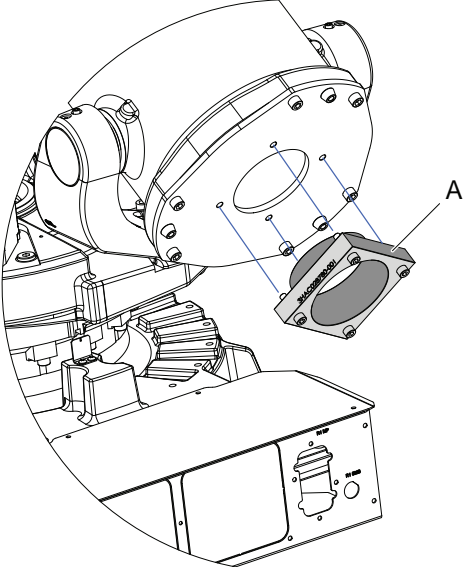
	Action	Note
3	<p> DANGER</p> <p>Turn off all:</p> <ul style="list-style-type: none"> • electric power supply • hydraulic pressure supply • air pressure supply <p>to the robot, before entering the robot working area.</p>	
4	<p>Remove the cover plate on the back of the balancing device.</p> <p> DANGER</p> <p>DO NOT remove any other screws than the rear cover attachment screws.</p>	 <p>xx130000554</p>
5	<p>Fit the Distance tool on the back of the balancing device using the four screws.</p> <p> DANGER</p> <p>Use caution when tightening the screws. The threads in the cover can be damaged if more tightening torque than 45 Nm is used, risking that the Distance tool is not properly fitted.</p>	<p>Tightening torque: 45 Nm Attachment screws: M10 quality 12.9 (4 pcs)</p>  <p>xx080000480</p> <p>A Distance tool: 3HAC030662-001</p>
6	Turn the power on temporary.	
7	Jog axis-2 to the calibration position. The balancing device is now unloaded.	This is done to compress the balancing device springs, making it possible to remove the front shaft of the balancing device.
8	Let the Distance tool stay fitted during the continued procedure.	

Continues on next page

4 Repair

4.6.3 Replacing the rear bearings on the balancing device



Continued

	Action	Note
9	 DANGER Turn off all: <ul style="list-style-type: none"> • electric power supply • hydraulic pressure supply • air pressure supply to the robot, before entering the robot working area.	

Removing the bearing, cradle

Use these procedures to remove the bearing in the cradle.

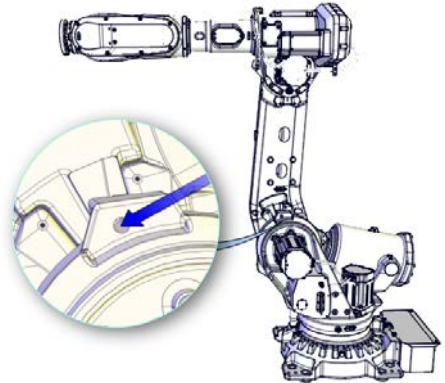
Preparations before removing the rear bearings

	Action	Note
1	Jog axis-2 to the calibration position (if not already in this position).	
2	Fit a locking screw through the hole for the lock screw in the frame and into the lower arm (or using a lifting accessory or similar). The lock screw is used to secure the weight of the lower arm, in order to avoid accidents or damage.	Lock screw, M16x120  xx1200001116
3	 DANGER Turn off all: <ul style="list-style-type: none"> • electric power supply • hydraulic pressure supply • air pressure supply to the robot, before entering the robot working area.	
4	Remove any equipment, if fitted, on or close to the balancing device.	

Continues on next page

4.6.3 Replacing the rear bearings on the balancing device

Continued

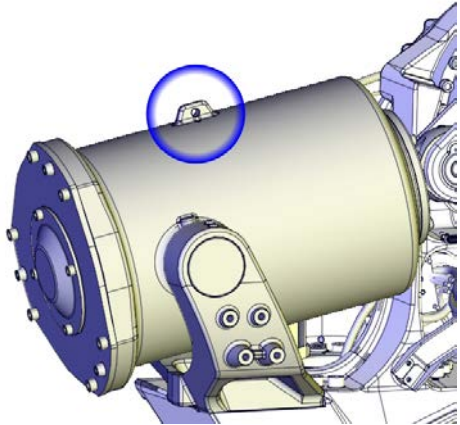
	Action	Note
5	<p> CAUTION</p> <p>The weight of the balancing device (excluding cradle) is 140 kg (IRB 6700 -235/2.65, -205/2.80, -175/3.05, -150/3.20, -200/2.60, -155/2.85) 185 kg (IRB 6700 -300/2.70, -245/3.00) All lifting accessories used must be sized accordingly.</p>	
6	Fit a lifting shackle to the balancing device.	<p>Lifting shackle: SA-10-8-NA1</p>  <p>xx130000661</p>
7	Fit the lifting accessory to the shackle and raise to unload the weight.	Lifting accessory (chain): 3HAC15556-1

Removing the shaft end, cradle

The procedure of removing the shaft end in the cradle is the same on both sides.



Note

Remove one shaft end at a time!

Continues on next page

4 Repair

4.6.3 Replacing the rear bearings on the balancing device

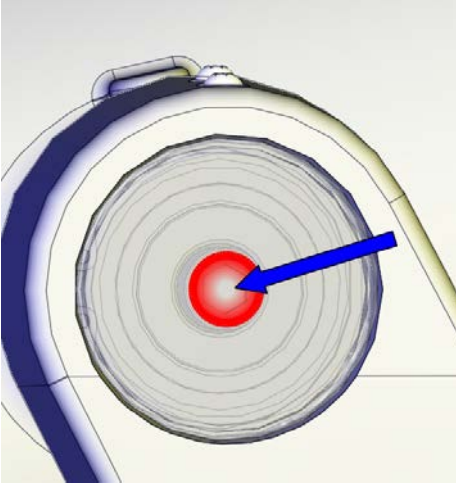
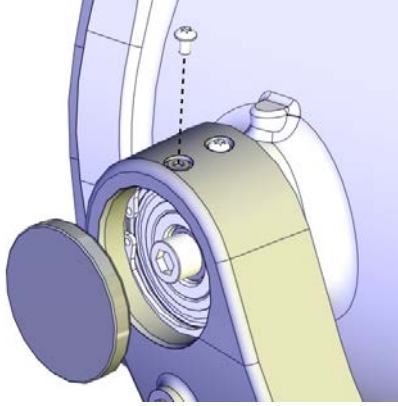
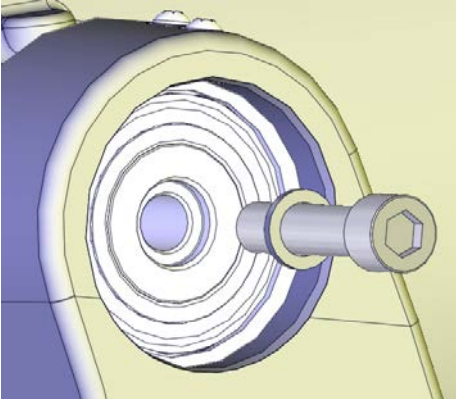

Continued

	Action	Note
1	<p>Remove the VK cover using one of the recommended methods:</p> <ul style="list-style-type: none">• Drive a screwdriver (or similar) through the VK cover, as close as possible to the center of the VK cover, and bend out the cover. If not making a hole in the center of the VK cover, there is a risk of damaging the bearing inside. The damaged VK cover must be replaced with a new.• Remove the protection screw from the vent hole and use air pressure through the hole to blow out the cover. The cover can be reused if not damaged.	<p>VK cover, 90x12: 3HAA2166-28 Position for screwdriver:</p>  <p>xx130000662</p> <p>Vent hole for air pressure:</p>  <p>xx1700002189</p>
2	Wipe off all residual grease inside the recess.	
3	Unscrew the attachment screw securing the shaft.	 <p>xx130000663</p>

Continues on next page

4.6.3 Replacing the rear bearings on the balancing device

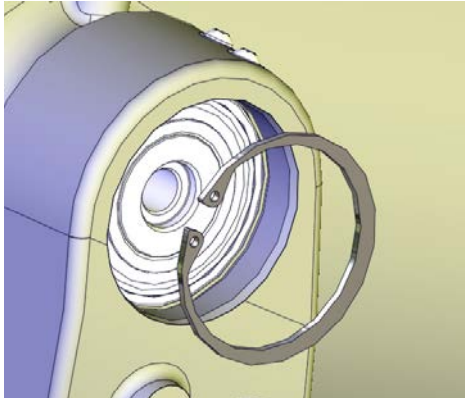
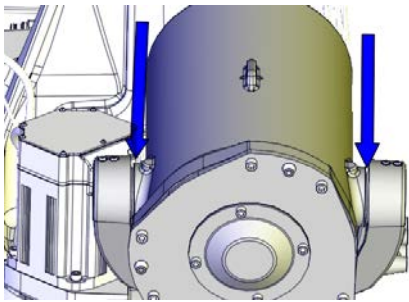
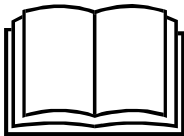
Continued



	Action	Note
4	Remove the retaining ring bore.	 <p>xx130000664</p>
5	Before pulling out the shaft end, put a big screw driver between the cradle and balancing device and use it as a distance tool.	 <p>xx130000838</p>
6	<p>IRB 6700 -235/2.65, -205/2.80, -175/3.05, -150/3.20, -200/2.60, -155/2.85.</p> <p>Pull out the shaft end with bearing, sealing and distance using the dismantle and mounting tool, according to user instructions enclosed with the equipment.</p>  <p>xx090000813</p> <p>Go to the user instructions enclosed with the press tool.</p> <p> DANGER</p> <p>Handling the tool incorrectly will cause serious injury.</p> <p>Read and follow enclosed user instructions for the tool.</p>	<p>Dismantle and mounting tool: 3HAC028920-001</p> <p>User instructions are enclosed with the tool.</p>

Continues on next page

4 Repair

4.6.3 Replacing the rear bearings on the balancing device

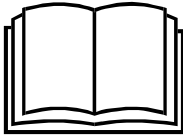
Continued

	Action	Note
7	<p>IRB 6700 -300/2.70, -245/3.00.</p> <p>Pull out the shaft end with the groove ball bearing using the dismantle and mounting tool, according to user instructions enclosed with the equipment.</p>  <p>xx0900000813</p> <p>Go to the user instructions enclosed with the press tool.</p> <p> DANGER</p> <p>Handling the tool incorrectly will cause serious injury.</p> <p>Read and follow enclosed user instructions for the tool.</p>	<p>Dismantle and mounting tool: 3HAC028920-001</p> <p>User instructions are enclosed with the tool.</p>

Refitting the bearing, cradle

Use these procedures to refit the bearing in the cradle.

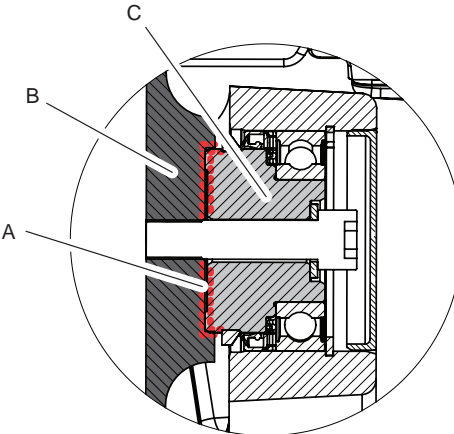

Refitting the shaft end and rear bearings

	Action	Note
1	<p>Wipe clean all contact surfaces from residual grease and other contamination inside the recess.</p>	
2	<p><i>Foundry Plus:</i></p> <p>Apply Mercasol on matching surfaces on the axis and balancing device. See the figure.</p>	 <p>xx1400000367</p> <p>A Mercasol (red dotted lines) B Balancing device C Shaft</p>

Continues on next page

4.6.3 Replacing the rear bearings on the balancing device

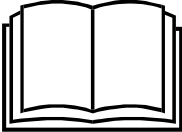
Continued

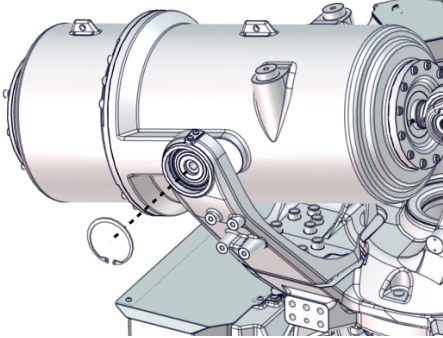
	Action	Note
3	<p>Apply some grease in the hole for the bearing in the cradle.</p> <p> Note</p> <p>Do not apply grease on surfaces with Mercasol.</p>	
4	<p>Apply a threaded bar into the hole in the balancing device using the dismantle and mounting tool, according to user instructions enclosed with the equipment.</p> <p></p> <p>xx0900000813</p> <p>Go to the user instructions enclosed with the press tool.</p> <p> DANGER</p> <p>Handling the tool incorrectly will cause serious injury.</p> <p>Read and follow enclosed user instructions for the tool.</p>	<p>Dismantle and mounting tool: 3HAC028920-001</p> <p>User instructions are enclosed with the tool.</p>
5	<p>Fit the retaining ring bore.</p>	 <p>xx1700000343</p>
6	<p>Apply locking liquid on the attachment screw.</p>	<p>Loctite 243, 3HAB7116-1</p>

Continues on next page

4 Repair

4.6.3 Replacing the rear bearings on the balancing device

Continued

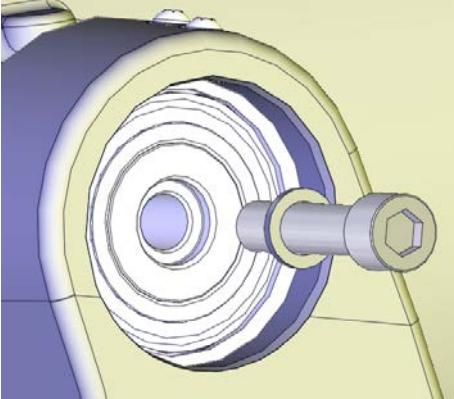
	Action	Note
7	<p>While using the screw driver between the cradle and balancing device as a distance tool, tighten the attachment screw completely.</p> <p>Secure the balancing device.</p>	<p>Tightening torque: 280 Nm.</p>  <p>xx130000663</p>
8	Fit a VK cover to protect the bearing.	

Remove the lifting accessories

	Action	Note
1	Remove the lifting accessories.	

Concluding procedure

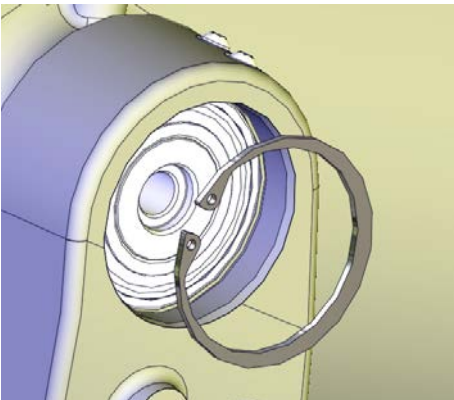
	Action	Note
1	Refit the retaining ring bore.	 <p>xx130000664</p>

Continues on next page

4.6.3 Replacing the rear bearings on the balancing device

Continued

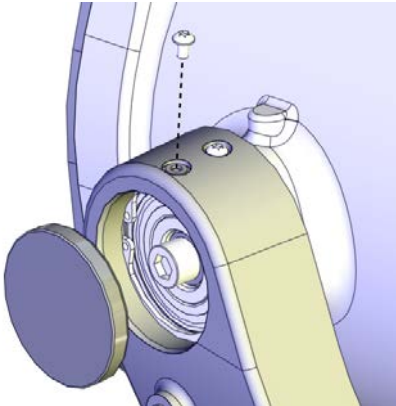
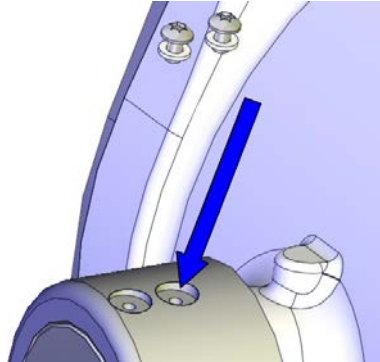
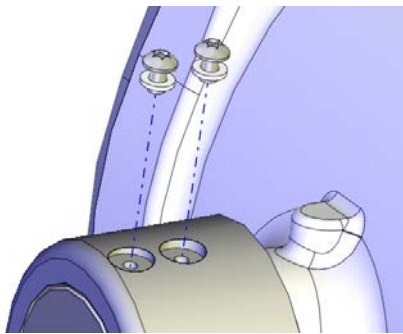

	Action	Note
2	Refit the VK-cover.  Note Temporarily remove the screw on the cradle to let go of overpressure if the VK covers are hard to fit.	VK cover, 90x12, 3HAA2166-28  xx1700002189
3	Unscrew both screws and refill grease from the inner hole (See figure).	Grease: 3HAA1001-294  xx1300000832
4	Refit the screws.	 xx1300000833
5	Wipe clean from residual grease.	
6	Remove the Distance tool.	

Continues on next page

4 Repair

4.6.3 Replacing the rear bearings on the balancing device

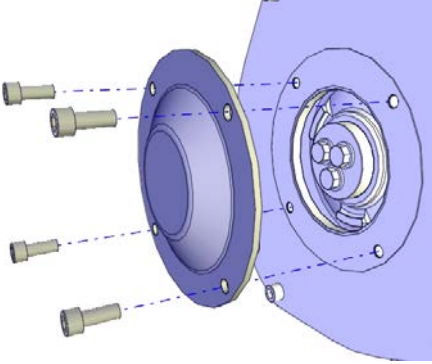
Continued

	Action	Note
7	Apply flange sealant and refit the cover plate on the back of the balancing device.	<p>Screws: M10 quality 12.9. Tightening torque: 50 Nm. Flange sealant for conical fittings: Loctite 577.</p>  <p>xx130000554</p>
8	 DANGER Make sure all safety requirements are met when performing the first test run.	

4.6.4 Replacing the stop pin

Location of the stop pin

The stop pin is located as shown in the figure.

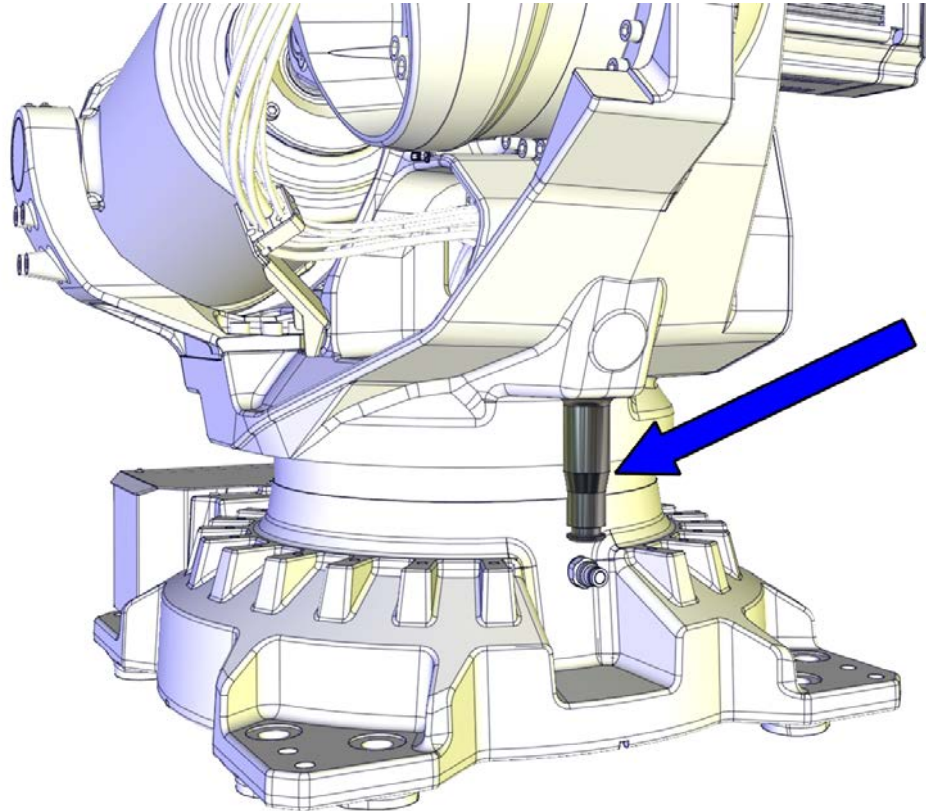

xx130000475

Spare part

Equipment	Article number	Note
Stop pin	See <i>Product manual, spare parts - IRB 6700/IRB 6700Inv.</i> <i>Product manual, spare parts - IRB 6790</i>	

Required tools and equipment

Equipment, etc.	Article number	Note
Standard toolkit	-	Content is defined in section Standard toolkit on page 814 .

Required consumables

Consumable	Article number	Note
Locking liquid	3HAB7116-1	Loctite 243
<i>Foundry plus:</i> Rust preventive	3HAC034903-001	Mercasol 3110 Waxcoat. Recommended drying time is 24h.





Continues on next page

4 Repair

4.6.4 Replacing the stop pin

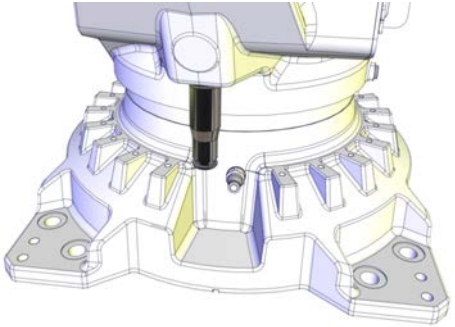
Continued

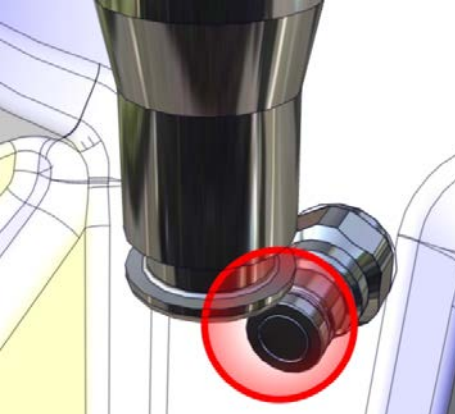
Removing the stop pin

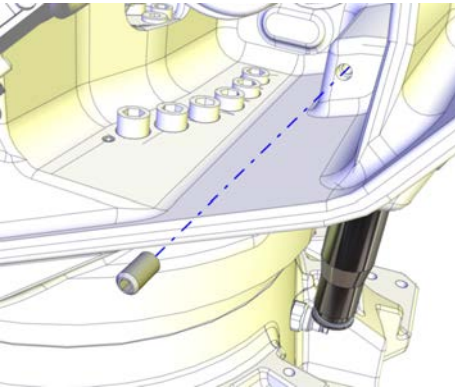
	Action	Note
1	IRB 6700 - 235/2.65, IRB 6700 - 205/2.80, IRB 6700 - 175/3.05, IRB 6700 - 150/3.20 IRB 6700 - 200/2.60, IRB 6700 - 155/2.85 Jog the robot to this position: <ul style="list-style-type: none"> axis 1 = -5° 	 <p>xx1300000479</p>
2	IRB 6700 - 235/2.65, IRB 6700 - 205/2.80, IRB 6700 - 175/3.05, IRB 6700 - 150/3.20 IRB 6700 - 200/2.60, IRB 6700 - 155/2.85  Note If the axis-1 is not in this position the stop pin will not be able to go free from the axis-1 oil plug draining, when removed.	 <p>xx1300000478</p>
3	 DANGER Turn off all: <ul style="list-style-type: none"> electric power supply hydraulic pressure supply air pressure supply to the robot, before entering the robot working area.	
4	Hold the mechanical stop pin in a firm grip, use caution and remove it by unscrewing the set screw, cup point.  CAUTION The mechanical stop weighs 5 kg and may unexpectedly fall down when the set screw is removed.	 <p>xx1300000476</p>

Continues on next page

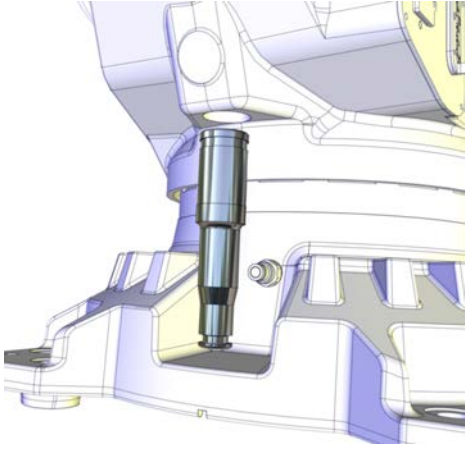
	Action	Note
5	Remove the stop pin.	 <p>xx1300000477</p>

Refitting the stop pin

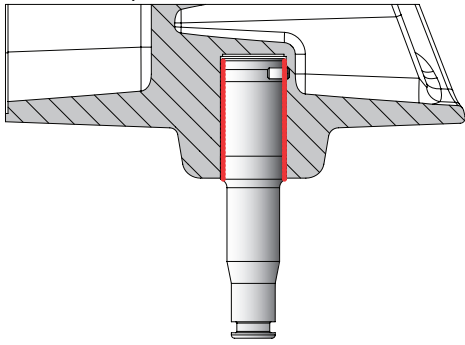
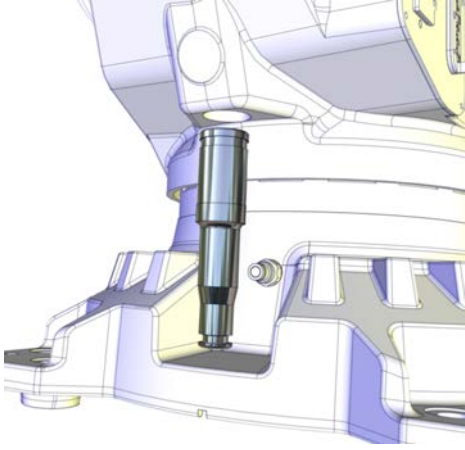
	Action	Note
1	<p><i>Foundry Plus:</i> Apply Mercasol on the surfaces shown in the figure, on stop pin and in the hole as shown in the figure.</p>	<p>Rust preventive: 3HAC034903-001 (Mercasol 3110 Waxcoat. Recommended drying time is 24h.).</p>  <p>xx1400000378</p>
2	Fit the stop pin.	 <p>xx1300000477</p>

Continues on next page

4 Repair

4.6.4 Replacing the stop pin

Continued

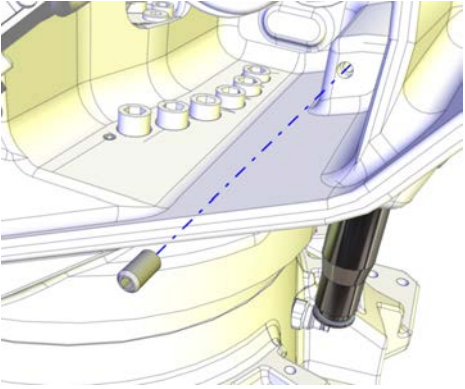
	Action	Note
3	Apply locking liquid on the set screw, and secure the stop pin.	<p>Loctite 243 Set screw: M10x20</p>  <p>xx1300000476</p>

4.7 Motors

4.7.1 Replacing the axis-1 motor

Location of the axis-1 motor

The motor is located as shown in the figure.

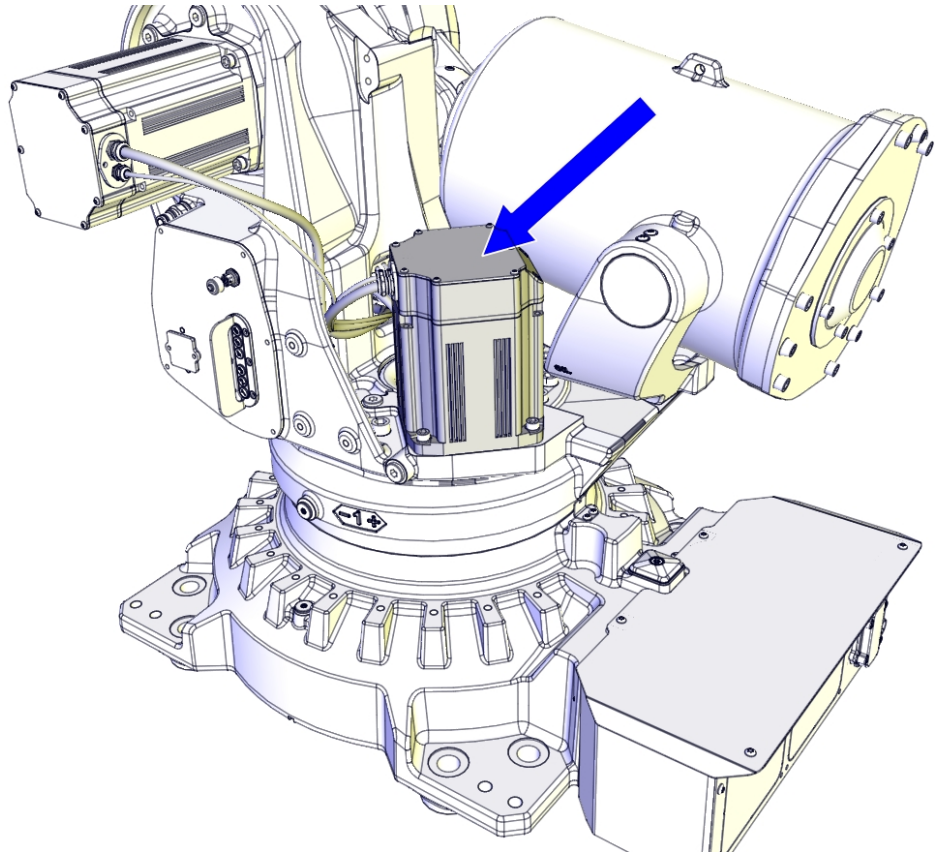

xx1200001064

Summary of the replacement procedure

This list is a brief summary of the replacement procedure, containing the major actions to be performed.

- 1 Attach the lifting tools
- 2 Replace the motor
- 3 Remove the lifting tools.

Spare parts

Spare part	Spare part number	Note
Axis-1 motor	See <i>Product manual, spare parts - IRB 6700/IRB 6700Inv.</i> <i>Product manual, spare parts - IRB 6790</i>	

Continues on next page

4 Repair

4.7.1 Replacing the axis-1 motor

Continued

Consumables

Equipment, etc.	Article number	Note
Grease	3HAC042536-001	Used to lubricate o-rings, Shell Gadus S2.
O-ring ⁱ	3HAB3772-111 (circular profile) / 3HAC054692-002 (hexagon profile)	D=169.5x3 Used on motor cover.
O-ring	3HAB3772-107	D=102x3 Used on motor flange.

ⁱ The cross-section profile is either circular or hexagon. If only ordering the o-ring, order the same profile that is currently installed in the connection box.

Required tools and equipment

Equipment, etc.	Article number	Note
Lifting accessory, motor	3HAC14459-1	
Roundsling, 1 m	-	Length: 1 m, lifting capacity: 1,000 kg.
Removal tool kit M12 and M14	3HAC057339-002	Required dimension of removal tool depends on motor type A or B, see Identifying the motor by article number on page 805 Used to push out the motor, if necessary. Always use removal tools in pairs.
Guide pin, M10x150	3HAC15521-2	Always use guide pins in pairs.
Bits extender	3HAC12342-1	300 mm, bits 1/2"
Rotation tool	3HAB7887-1	Used to rotate the motor pinion.
24 VDC power supply	-	Used to release the motor brakes.
Leak-down tester	-	
Calibration Pendulum toolkit	3HAC15716-1	Required if Calibration Pendulum is the valid calibration method for the robot.
Calibration tool box, Axis Calibration	3HAC055412-001	Delivered as a set of calibration tools. Required if Axis Calibration is the valid calibration method for the robot.
Standard toolkit	-	Content is defined in section Standard toolkit on page 814 .

Continues on next page

Deciding calibration routine

Decide which calibration routine to be used, based on the information in the table. Depending on which routine is chosen, action might be required prior to beginning the repair work of the robot, see the table.

	Action	Note
1	Decide which calibration routine to use for calibrating the robot. <ul style="list-style-type: none"> Reference calibration. External cable packages (DressPack) and tools can stay fitted on the robot. Fine calibration. All external cable packages (DressPack) and tools must be removed from the robot. 	
	If the robot is to be calibrated with reference calibration: Find previous reference values for the axis or create new reference values. These values are to be used after the repair procedure is completed, for calibration of the robot. If no previous reference values exist, and no new reference values can be created, then reference calibration is not possible.	Follow the instructions given in the reference calibration routine on the FlexPendant to create reference values. Creating new values requires possibility to move the robot. Read more about reference calibration for Axis Calibration in Reference calibration routine on page 782 . Read more about reference calibration for Pendulum Calibration in <i>Operating manual - Calibration Pendulum</i> .
	If the robot is to be calibrated with fine calibration: Remove all external cable packages (DressPack) and tools from the robot.	

Removing the axis-1 motor

These procedures describe how to remove the motor.

Preparations before removing the axis-1 motor

	Action	Note
1	Decide which calibration routine to use, and take actions accordingly prior to beginning the repair procedure.	
2	Jog the robot to the synchronization position.	
3	 DANGER Turn off all: <ul style="list-style-type: none"> electric power supply hydraulic pressure supply air pressure supply to the robot, before entering the safeguarded space.	

Continues on next page

4 Repair

4.7.1 Replacing the axis-1 motor

Continued

Removing the axis-1 motor protection plates

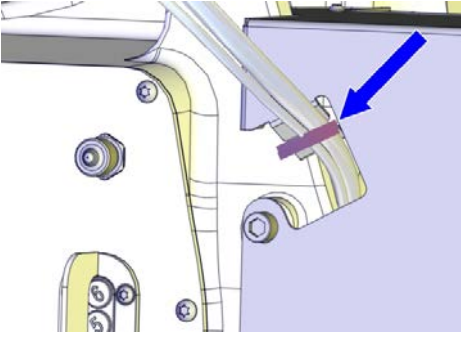
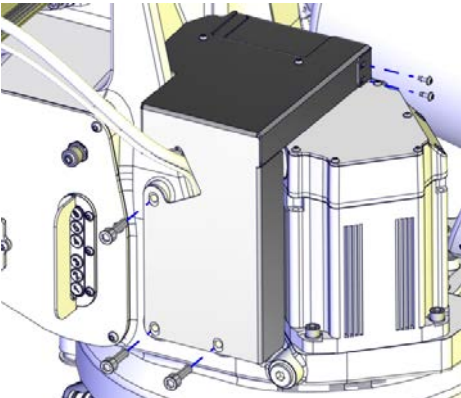
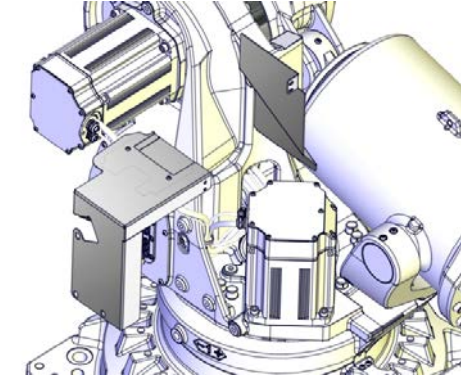
	Action	Note
1	<p><i>Foundry Plus.</i> Cut the cable tie that hold the axis-1 and axis-2 motor cables on the protection plates.</p>	 <p>xx140000722</p>
2	<p><i>Foundry Plus.</i> Disassemble the protection plates by removing five of the attachment screws (three M10x30 and two of the M5x12 screws).</p>	 <p>xx140000723</p>
3	<p><i>Foundry Plus.</i> Remove the two protection plates.</p>	 <p>xx140000724</p>

Disconnecting the motor cables

	Action	Note
1	<p> DANGER Make sure that all supplies for electrical power, hydraulic pressure, and air pressure are turned off.</p>	

Continues on next page

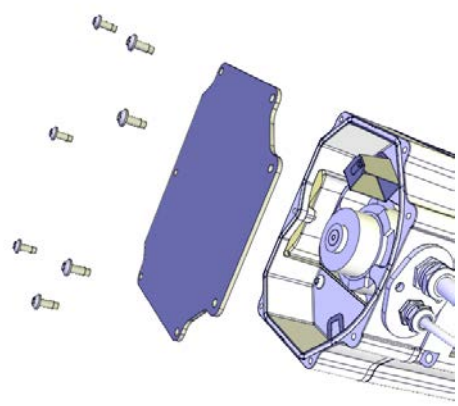
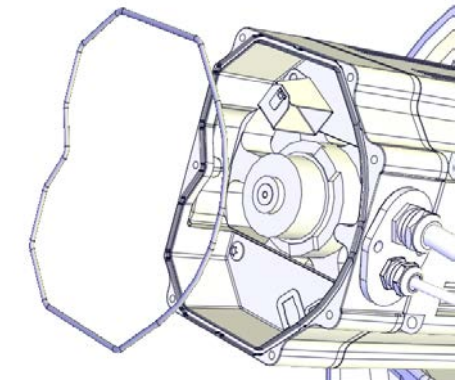
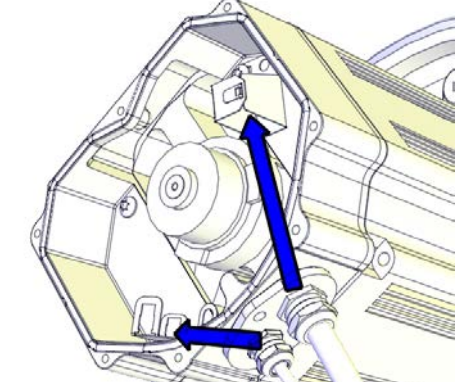
	Action	Note
2	Unscrew the attachment screws and washers and remove the motor cover.	 <p>xx1200001135</p>
3	Make sure the o-ring is present.	 <p>xx1200001070</p>
4	Disconnect the motor cables.	 <p>xx1200001066</p>

Continues on next page



4 Repair

4.7.1 Replacing the axis-1 motor

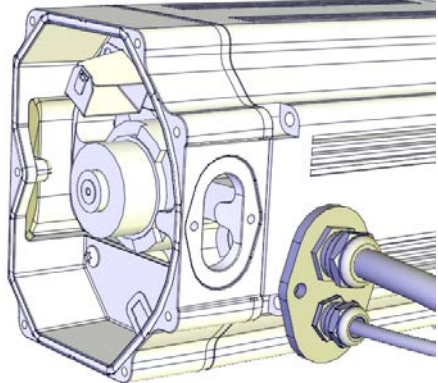

Continued

	Action	Note
5	<p>Remove the cable gland cover. Make sure the gasket is not damaged.</p> <p> Tip</p> <p>Make a note in which direction the cable gland hole is facing, if the motor will be removed too. The motor shall be refitted in the same position.</p>	 <p>xx1200001067</p>
6	Use caution and pull out the motor cables.	

Removing the axis-1 motor

	Action	Note
1	<p> DANGER</p> <p>Make sure that all supplies for electrical power, hydraulic pressure, and air pressure are turned off.</p>	
2	Attach the lifting accessories.	<p>Lifting accessory (chain): 3HAC15556-1 Lifting accessory, motor: 3HAC14459-1.</p>
3	<p>To release the brakes, connect the 24 VDC power supply. Connect to R2.MP1-connector:</p> <ul style="list-style-type: none"> • + = pin 2 • - = pin 5 	24 VDC power supply
4	<p> CAUTION</p> <p>The weight of the motor is 25 kg All lifting accessories used must be sized accordingly.</p>	

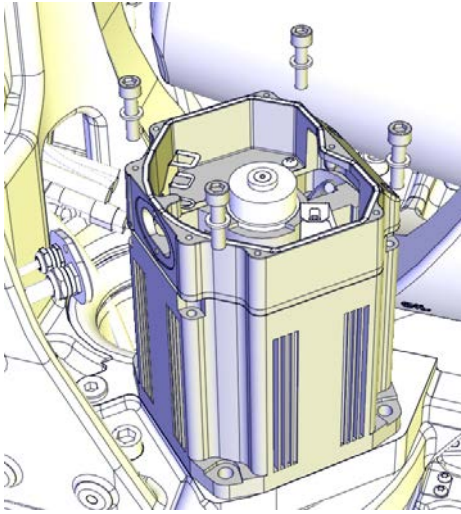
Continues on next page

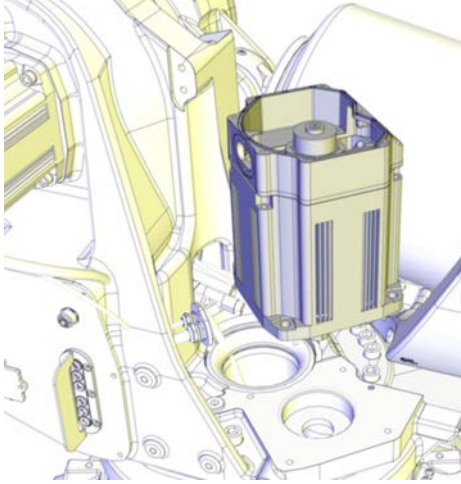
	Action	Note
5	<p>Unscrew the attachment screws and washers. Use a bits extender to reach the screws.</p>	<p>Bits extender: 3HAC12342-1</p>  <p>xx1200001071</p>
6	<p>Fit guide pins in opposite holes.</p>	<p>Guide pin, M10x150: 3HAC15521-2 Always use guide pins in pairs.</p>
7	<p> CAUTION Whenever parting/mating motor and gear-box, the gears may be damaged if excessive force is used.</p>	
8	<p>If needed, use removal tools to help remove the motor.</p>	<p>Removal tool kit M12 and M14: 3HAC057339-002 Required dimension of removal tool depends on motor type A or B, see Identifying the motor by article number on page 805 Used to push out the motor, if necessary. Always use removal tools in pairs.</p>
9	<p>Use caution and lift the motor straight up to get the pinion parted from the gear.</p>	<p>Lifting accessory (chain): 3HAC15556-1 Lifting accessory, motor: 3HAC14459-1.</p>  <p>xx1200001072</p>

Continues on next page

4 Repair

4.7.1 Replacing the axis-1 motor



Continued

	Action	Note
10	Disconnect the 24 VDC power supply.	

Refitting the axis-1 motor

These procedures describes how to refit the motor.

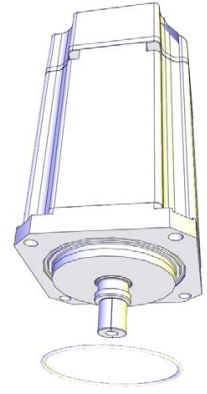

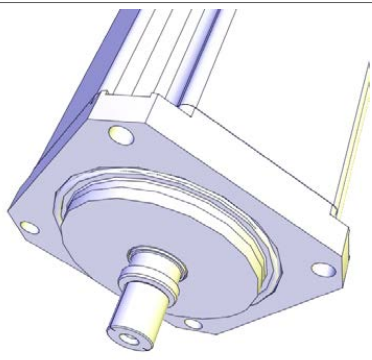
Preparations prior to refitting motor

	Action	Note
1	 DANGER Make sure that all supplies for electrical power, hydraulic pressure, and air pressure are turned off.	
2	Remove any old paint residues or other contamination from the contact surfaces on both the motor and the mating parts. Wipe clean the contact surfaces and the o-ring groove.	
3	Fit a new o-ring.	 xx1200001019
4	Make sure the o-ring is seated in the groove.  Tip Lubricate the o-ring with some grease for a better fitting in the groove.	 xx1200001020

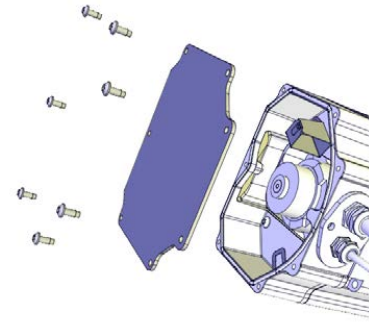
Continues on next page

	Action	Note
5	If the motor is a new spare part, remove the cover.	 <p>xx1200001135</p>

Securing the axis-1 motor

	Action	Note
1	Fit guide pins in opposite holes.	Guide pin, M10x150: 3HAC15521-2 Always use guide pins in pairs.
2	 CAUTION The motor weighs 25 kg. All lifting accessories used must be sized accordingly.	
3	Apply the lifting accessory.	Lifting accessory, motor: 3HAC14459-1.
4	Fit the rotation tool.	Rotation tool: 3HAB7887-1
5	Connect the 24 VDC power supply to release the brakes. To release the brakes, connect the 24 VDC power supply as described in the list. Connect to R2.MP1-connector: <ul style="list-style-type: none"> • + = pin 2 • - = pin 5 	
6	 CAUTION Whenever parting/mating motor and gearbox, the gears may be damaged if excessive force is used.	

Continues on next page

4 Repair

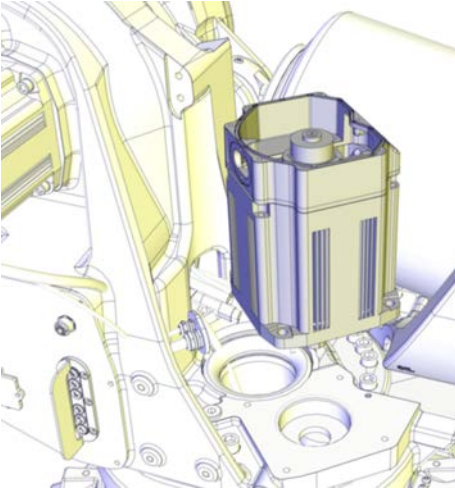
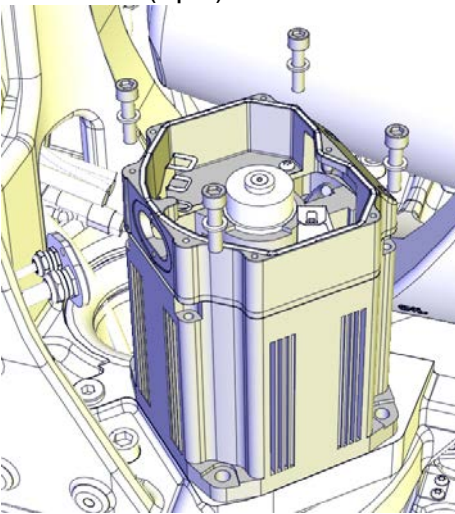

4.7.1 Replacing the axis-1 motor

Continued

	Action	Note
7	<p>Lower the motor into position.</p> <ul style="list-style-type: none">• Make sure that the motor pinion is properly mated to the gear in the gearbox.• Make sure that the motor pinion does not get damaged.• Make sure that the direction of the cable gland exit is facing the correct way.	<p>Lifting accessory (chain): 3HAC15556-1 Lifting accessory, motor: 3HAC14459-1.</p>  <p>xx1200001072</p>
8	<p>Secure the motor with its attachment screws and washers. Use a bits extender to reach the screws.</p>	<p>Bits extender: 3HAC12342-1 Tightening torque: 50 Nm. Screws: M10x30 Steel 12.9 Gle 603+Geo500 (4 pcs)</p>  <p>xx1200001071</p>
9	<p>Perform a leak-down test (if not already done).</p>	<p>See Performing a leak-down test on page 186.</p>
10	<p>Disconnect the 24 VDC power supply.</p>	

Continues on next page

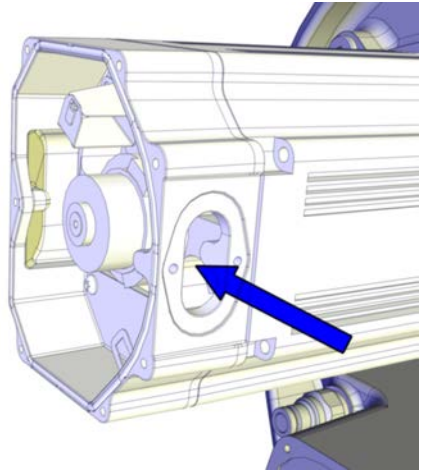
Connecting the motor cables

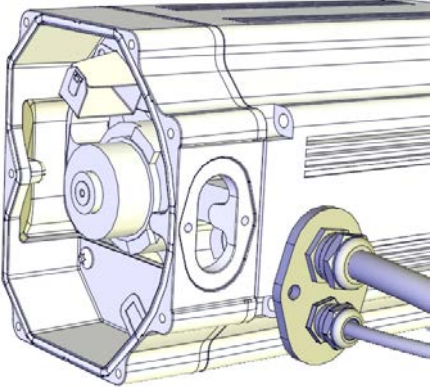
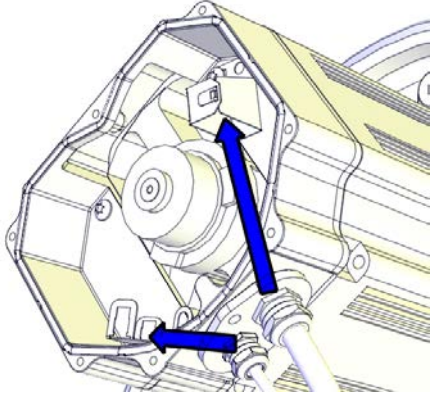

	Action	Note
1	<p>Push the motor cables through the cable gland opening.</p>	 <p>xx130000738</p>
2	<p>Refit the cable gland cover.</p> <p> Note Replace the gasket if damaged.</p>	 <p>xx1200001067</p>
3	<p>Connect the motor cables. Connect in accordance with the markings on the connectors.</p>	 <p>xx1200001066</p>

Continues on next page

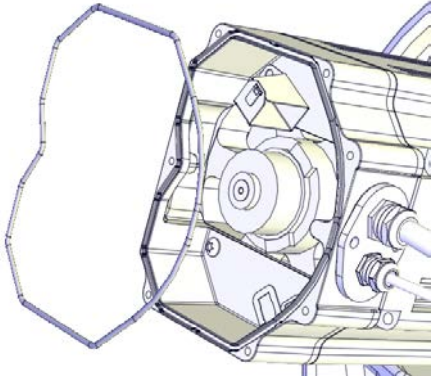

4 Repair

4.7.1 Replacing the axis-1 motor

Continued

	Action	Note
4	<p>Inspect the o-ring.</p> <p> Note</p> <p>Replace if damaged.</p>	<p>O-ring, axis-1: 3HAB3772-111 (circular profile) / 3HAC054692-002 (hexagon profile)</p> <p>O-ring, axis-2: 3HAB3772-111 (circular profile) / 3HAC054692-002 (hexagon profile)</p> <p>O-ring, axis-3: 3HAB3772-111 (circular profile) / 3HAC054692-002 (hexagon profile)</p> <p>O-ring, axis-4: 3HAB3772-110 (circular profile) / 3HAC054692-001 (hexagon profile)</p>  <p>xx1200001070</p>
5	Wipe clean o-ring and o-ring groove.	
6	<p>Refit the o-ring.</p> <p> Tip</p> <p>Lubricate the o-ring with some grease for a better fitting in the groove.</p>	
7	<p> CAUTION</p> <p>When fitting the motor cover, make sure that none of the cables inside will be damaged.</p>	

Continues on next page

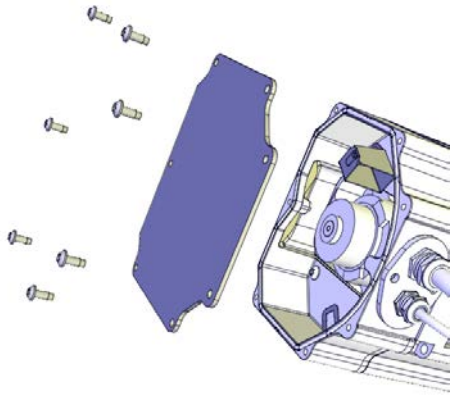
	Action	Note
8	<p>Refit the motor cover with it's attachment screws.</p> <p> Note</p> <p>Do not reuse the self-threading attachment screws. Replace with standard attachment screws or the threads will be damaged.</p> <p> Note</p> <p>Make sure the o-ring is undamaged and properly fitted.</p>	<p>Attachment screws: M5x12 8.8 (7 pcs)</p>  <p>xx1200001135</p>
9	<p>Make sure that the covers are tightly sealed.</p>	

Concluding procedure

Use this procedure for the concluding refitting.

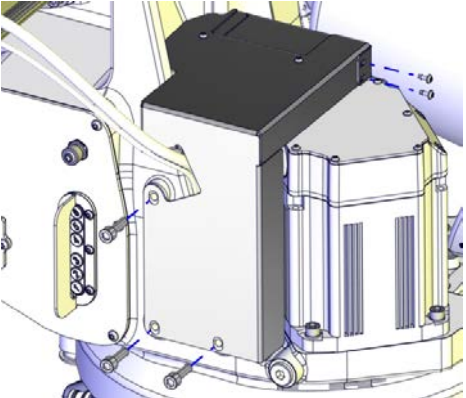
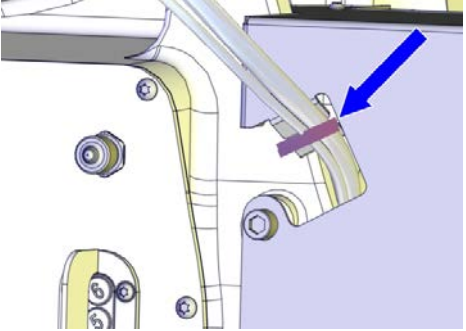
	Action	Note
1	<p><i>Foundry Plus:</i></p> <p>Refit the protection plates with three M10x30 and two M5x12 attachment screws.</p> <p> Note</p> <p>Make sure that the axis-1 and axis-2 motor cables are run through the hole in the protection plates correctly.</p>	 <p>xx1400000723</p>
2	<p><i>Foundry Plus:</i></p> <p>Secure the axis-1 and axis-2 motor cables with a cable tie.</p>	 <p>xx1400000722</p>

Continues on next page

4 Repair

4.7.1 Replacing the axis-1 motor

Continued

	Action	Note
3	Re-calibrate the robot.	Pendulum Calibration is described in <i>Operating manual - Calibration Pendulum</i> , enclosed with the calibration tools. Axis Calibration is described in Calibrating with Axis Calibration method on page 781 . General calibration information is included in section Calibration on page 767 .
4	 DANGER Make sure all safety requirements are met when performing the first test run.	

4.7.2 Replacing the axis-2 motor

Location of the motor

The motor is located as shown in the figure.

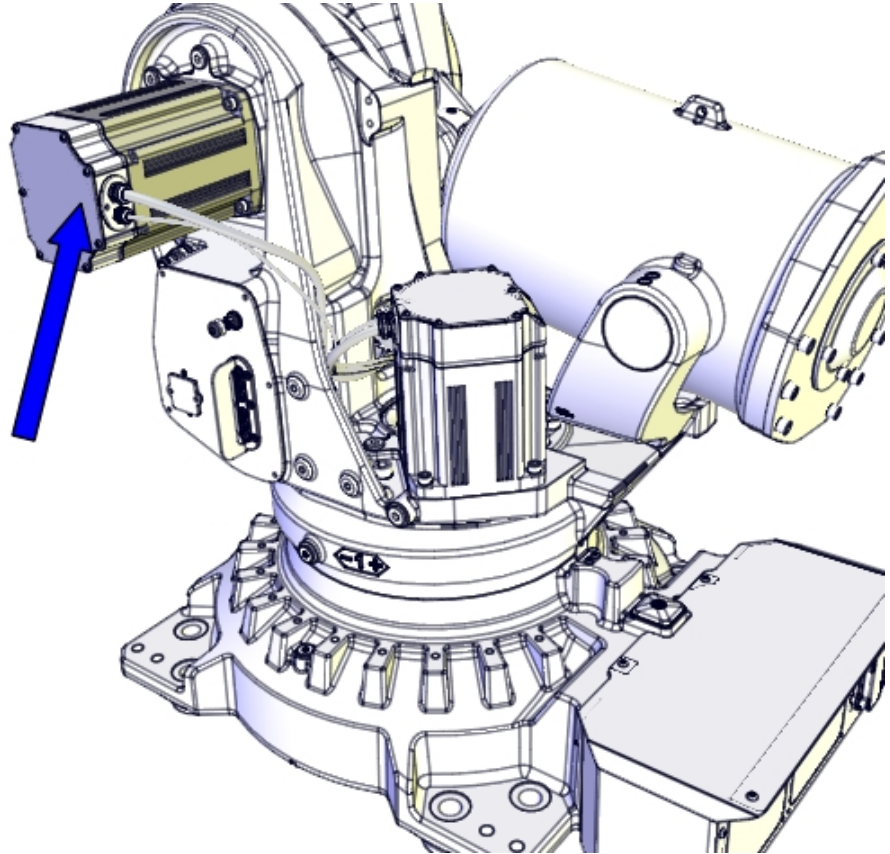

xx1200001112

Summary of the replacement procedure

This list is a brief summary of the replacement procedure, containing the major actions to be performed.

- 1 Drain the axis-2 gearbox
- 2 Attach the lifting tools
- 3 Replace the motor
- 4 Remove the lifting tools
- 5 Refill the axis-2 gearbox with oil.

Spare parts

Spare part	Spare part number	Note
Axis-2 motor	See <i>Product manual, spare parts - IRB 6700/IRB 6700Inv.</i> <i>Product manual, spare parts - IRB 6790</i>	

Continues on next page

4 Repair

4.7.2 Replacing the axis-2 motor

Continued

Consumables

Equipment, etc.	Article number	Note
Grease	3HAC042536-001	Shell Gadus S2 Used to lubricate o-rings.
Rust preventive	3HAC034903-001	Mercasol 3110 Waxcoat. Recommended drying time is 24h.
O-ring ⁱ	3HAB3772-111 (circular profile) / 3HAC054692-002 (hexagon profile)	D=169.5x3 Used on motor cover.
O-ring	3HAB3772-107	D=102x3 Used on motor flange.

ⁱ The cross-section profile is either circular or hexagon. If only ordering the o-ring, order the same profile that is currently installed in the connection box.

Required tools and equipment

Equipment, etc.	Article number	Note
Lifting accessory, motor	3HAC15534-1	Lifting instruction 3HAC15640-2 enclosed.
Roundsling, 1 m	-	Length: 1 m, lifting capacity: 1,000 kg.
Removal tool kit M12 and M14	3HAC057339-002	Used to push out the motor, if necessary. Always use removal tools in pairs. Size depending on motor type, see Type A vs type B motors on page 805 .
Guide pin, M10x150	3HAC15521-2	Always use guide pins in pairs.
Bits extender	3HAC12342-1	300 mm, bits 1/2"
Rotation tool	3HAB7887-1	Used to rotate the motor pinion.
24 VDC power supply	-	Used to release the motor brakes.
Lock screw, M16x120	-	Used to secure lower arm.
Leak-down tester	-	
Calibration Pendulum toolkit	3HAC15716-1	Required if Calibration Pendulum is the valid calibration method for the robot.
Calibration tool box, Axis Calibration	3HAC055412-001	Delivered as a set of calibration tools. Required if Axis Calibration is the valid calibration method for the robot.
Standard toolkit	-	Content is defined in section Standard toolkit on page 814 .

Continues on next page

Deciding calibration routine

Decide which calibration routine to be used, based on the information in the table. Depending on which routine is chosen, action might be required prior to beginning the repair work of the robot, see the table.

	Action	Note
1	Decide which calibration routine to use for calibrating the robot. <ul style="list-style-type: none"> Reference calibration. External cable packages (DressPack) and tools can stay fitted on the robot. Fine calibration. All external cable packages (DressPack) and tools must be removed from the robot. 	
	If the robot is to be calibrated with reference calibration: Find previous reference values for the axis or create new reference values. These values are to be used after the repair procedure is completed, for calibration of the robot. If no previous reference values exist, and no new reference values can be created, then reference calibration is not possible.	Follow the instructions given in the reference calibration routine on the FlexPendant to create reference values. Creating new values requires possibility to move the robot. Read more about reference calibration for Axis Calibration in Reference calibration routine on page 782 . Read more about reference calibration for Pendulum Calibration in <i>Operating manual - Calibration Pendulum</i> .
	If the robot is to be calibrated with fine calibration: Remove all external cable packages (DressPack) and tools from the robot.	

Removing the motor

These procedures describes how to remove the motor.

Preparations before removing the axis-2 motor



	Action	Note
1	Decide which calibration routine to use, and take actions accordingly prior to beginning the repair procedure.	
2	Drain the oil from the gearbox.	See Draining the axis-2 gearbox on page 155 .
3	Jog the robot to the calibration position.	
4	 DANGER Secure the weight of the lower arm with a lock screw, before releasing the brakes on the axis-2 motor as well as before removing the axis-2 motor or the axis-2 gearbox.	

Continues on next page

4 Repair

4.7.2 Replacing the axis-2 motor

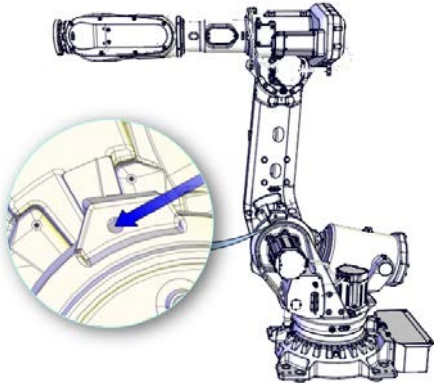

Continued

	Action	Note
5	<p>Insert the lock screw into the frame. If needed, adjust the position of axis-2 to make it possible to insert the lock screw. The lock screw is used to secure the weight of the lower arm, in order to avoid accidents or damage.</p> <p> Note</p> <p>Tighten the lock screw manually, no tools needed.</p>	<p>Lock screw, M16x120</p>  <p>xx1200001116</p>
6	<p> DANGER</p> <p>Turn off all:</p> <ul style="list-style-type: none"> • electric power supply • hydraulic pressure supply • air pressure supply <p>to the robot, before entering the safe-guarded space.</p>	
7	<p>Remove any equipment hindering access to the motor.</p>	

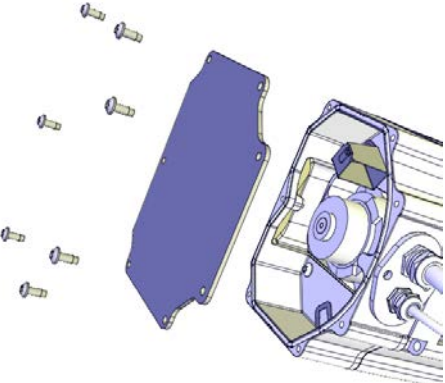
Disconnecting the motor cables

	Action	Note
1	<p> DANGER</p> <p>Make sure that all supplies for electrical power, hydraulic pressure, and air pressure are turned off.</p>	
2	<p>Unscrew the attachment screws and washers and remove the motor cover.</p>	 <p>xx1200001135</p>

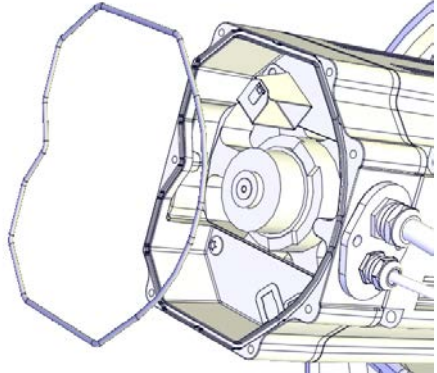
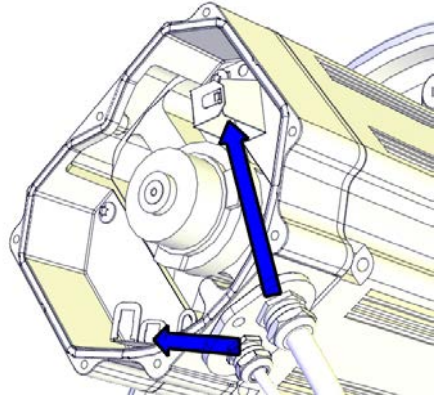
Continues on next page

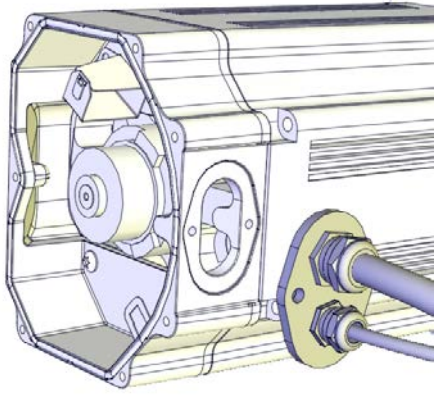
	Action	Note
3	Make sure the o-ring is present.	 <p>xx1200001070</p>
4	Disconnect the motor cables.	 <p>xx1200001066</p>
5	Remove the cable gland cover. Make sure the gasket is not damaged.  Tip Make a note in which direction the cable gland hole is facing, if the motor will be removed too. The motor shall be refitted in the same position.	 <p>xx1200001067</p>
6	Use caution and pull out the motor cables.	

Removing the axis-2 motor



	Action	Note
1	Before removing the motor, make sure that the axis-2 gearbox is completely drained.	

Continues on next page

4 Repair

4.7.2 Replacing the axis-2 motor

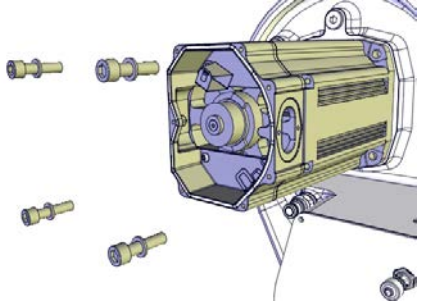
Continued

	Action	Note
2	 <p>DANGER</p> <p>When releasing the holding brakes of the motor, the lower arm will be movable and may fall down if not secured. Verify that the lower arm is secured as previously described, before continuing.</p>	
3	<p>To release the brake, connect the 24 VDC power supply.</p> <p>Connect to connector R2.MP2, axis-2 motor:</p> <ul style="list-style-type: none"> • + = pin 2 • - = pin 5 	
4	<p>Remove the attachment screws.</p> <p>Use a bits extender in order to reach the screws.</p>	<p>Bits extender: 3HAC12342-1</p>  <p>xx1200001117</p>
5	<p>Fit guide pins in opposite holes.</p>  <p>Tip</p> <p>Lubricate the guide pins with some grease to make the motor slide better.</p>	<p>Guide pin, M10x150: 3HAC15521-2</p> <p>Always use guide pins in pairs.</p>
6	 <p>CAUTION</p> <p>Whenever parting/mating motor and gearbox, the gears may be damaged if excessive force is used.</p>	
7	<p>If required, press the motor out of its position by using the removal tool in opposite holes of the motor.</p>	<p>Removal tool kit M12 and M14: 3HAC057339-002</p> <p>Removal tool kit M12 and M14: 3HAC057339-002</p> <p>Depending on motor type A or B, see Identifying the motor by article number on page 805</p> <p>Always use removal tools in pairs.</p>
8	<p>Disconnect the 24 VDC power supply.</p>	

Continues on next page

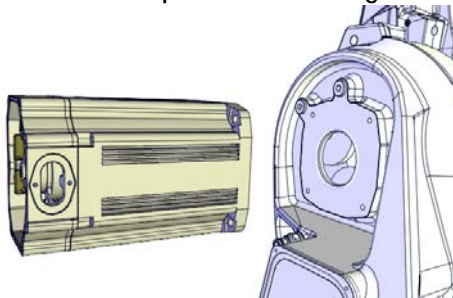
	Action	Note
9	 CAUTION The motor weighs 28 kg. All lifting accessories used must be sized accordingly.	
10	Carefully lift the motor out on the guide pins, in order to get the pinion away from the gear and let it rest on the guide pins.	
11	Fasten the lifting accessory. Attach the lifting chain to the accessory and an overhead crane.	Lifting accessory, motor: 3HAC15534-1 Lifting accessory (chain): 3HAC15556-1
12	Remove the motor by sliding it out on the guide pins and lift it off.	Make sure the pinion is not damaged.  xx1200001118

Refitting the motor

These procedures describes how to refit the motor.

Preparations prior to refitting motor



	Action	Note
1	 DANGER Make sure that all supplies for electrical power, hydraulic pressure, and air pressure are turned off.	
2	Remove any old paint residues or other contamination from the contact surfaces on both the motor and the mating parts. Wipe clean the contact surfaces and the o-ring groove.	

Continues on next page

4 Repair

4.7.2 Replacing the axis-2 motor

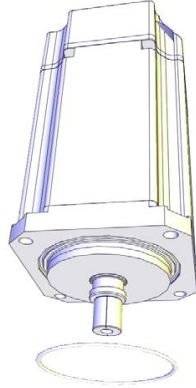

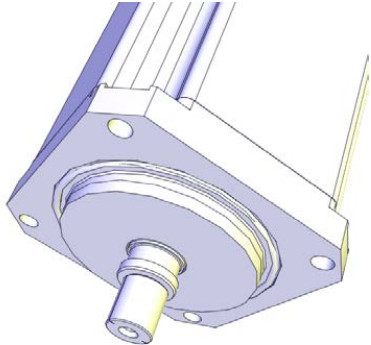
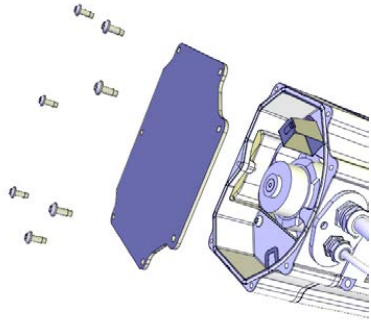
Continued

	Action	Note
3	Fit a new o-ring.	 xx1200001019
4	Make sure the o-ring is seated in the groove.  Tip Lubricate the o-ring with some grease for a better fitting in the groove.	 xx1200001020
5	If the motor is a new spare part, remove the cover.	 xx1200001135

Securing the axis-2 motor

	Action	Note
1	Fit guide pins in opposite holes.	Guide pin, M10x150: 3HAC15521-2 Always use guide pins in pairs.
2	 CAUTION The motor weighs 28 kg. All lifting accessories used must be sized accordingly.	

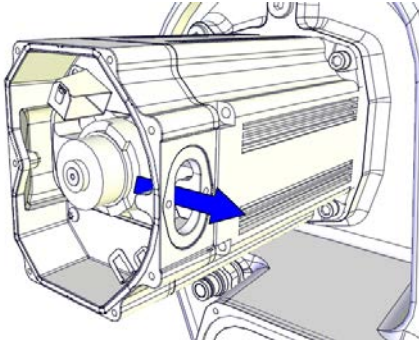
Continues on next page

	Action	Note
3	Apply the lifting accessory.	Lifting accessory, motor: 3HAC15534-1 Lifting accessory (chain): 3HAC15556-1
4	 Note Make sure the cable gland opening is turned the correct way.	 <small>xx1200001120</small>
5	Lift the motor and put it on the guide pins as close as possible to its final position without pushing the motor pinion into the gear.	
6	Remove the lifting accessory and allow the motor to rest on the guide pins.	
7	Apply the rotation tool and use it to rotate the pinion when mating it into the gear.	Rotation tool: 3HAB7887-1
8	To release the brakes, connect the 24 VDC power supply. Connect to connector R2.MP2, axis-2 motor: <ul style="list-style-type: none"> • + = pin 2 • - = pin 5 	
9	 CAUTION Whenever parting/mating motor and gearbox, the gears may be damaged if excessive force is used.	
10	Use caution and fit the motor in its final position while at the same time rotating the motor pinion slightly using the rotation tool. <ul style="list-style-type: none"> • Make sure that the motor pinion is properly mated to the gear of the gearbox. • Make sure that the motor pinion does not get damaged. • Make sure that the direction of the cable exit is facing the correct way. 	
11	Fit two of the attachment screws and washers.	Screws: M10x30 Steel 12.9 Gle 603+Geo500
12	Remove the guide pins and replace with the remaining attachment screws.	



4 Repair

4.7.2 Replacing the axis-2 motor

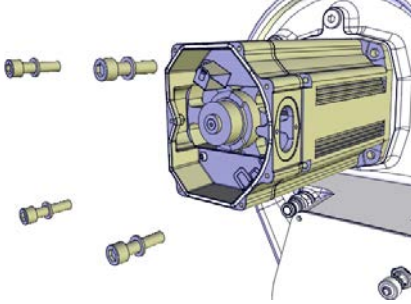

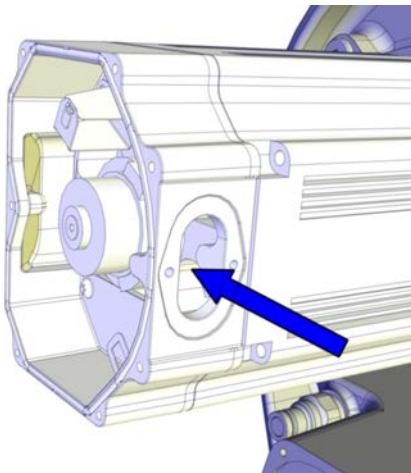

Continued

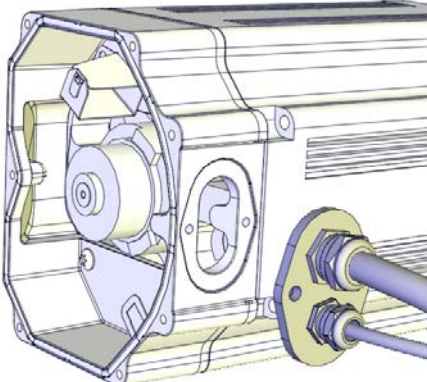
	Action	Note
13	Secure the motor with its attachment screws and washers. Use a bits extender in order to reach the screws.	Bits extender: 3HAC12342-1 Tightening torque: 50 Nm. Screw dimension: M10x30 Steel 12.9 Gle 603+Geo500 (4 pcs)  xx1200001117
14	Perform a leak-down test.	See Performing a leak-down test on page 186 .

Connecting the motor cables

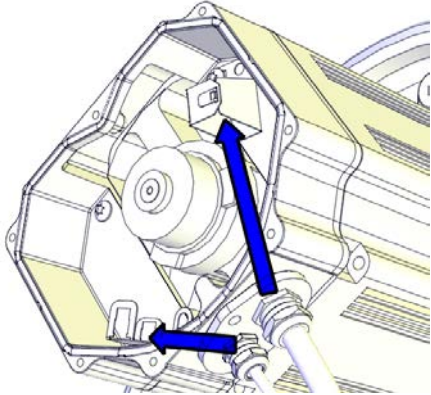
	Action	Note
1	Push the motor cables through the cable gland opening.	 xx1300000738
2	Refit the cable gland cover.  Note Replace the gasket if damaged.	 xx1200001067

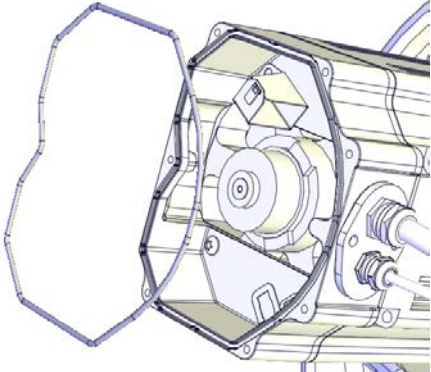
Continues on next page



	Action	Note
3	<p>Connect the motor cables. Connect in accordance with the markings on the connectors.</p>	 <p>xx1200001066</p>
4	<p>Inspect the o-ring.</p> <p> Note Replace if damaged.</p>	<p>O-ring, axis-1: 3HAB3772-111 (circular profile) / 3HAC054692-002 (hexagon profile) O-ring, axis-2: 3HAB3772-111 (circular profile) / 3HAC054692-002 (hexagon profile) O-ring, axis-3: 3HAB3772-111 (circular profile) / 3HAC054692-002 (hexagon profile) O-ring, axis-4: 3HAB3772-110 (circular profile) / 3HAC054692-001 (hexagon profile)</p>  <p>xx1200001070</p>
5	<p>Wipe clean o-ring and o-ring groove.</p>	
6	<p>Refit the o-ring.</p> <p> Tip Lubricate the o-ring with some grease for a better fitting in the groove.</p>	
7	<p> CAUTION When fitting the motor cover, make sure that none of the cables inside will be damaged.</p>	

Continues on next page

4 Repair

4.7.2 Replacing the axis-2 motor

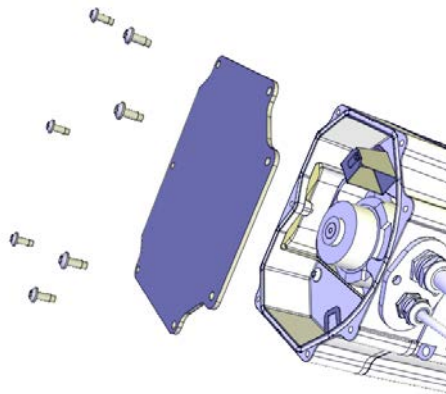

Continued

	Action	Note
8	<p>Refit the motor cover with its attachment screws.</p> <p> Note</p> <p>Do not reuse the self-threading attachment screws. Replace with standard attachment screws or the threads will be damaged.</p> <p> Note</p> <p>Make sure the o-ring is undamaged and properly fitted.</p>	<p>Attachment screws: M5x12 8.8 (7 pcs)</p>  <p>xx1200001135</p>
9	<p>Make sure that the covers are tightly sealed.</p>	

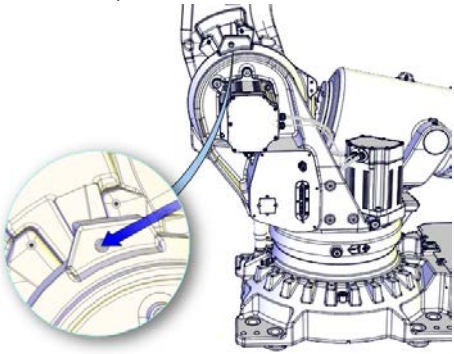
Concluding procedure

	Action	Note
1	<p>Use caution and jog axis-2 a little to facilitate the removal of the lock screw.</p>	
2	<p>Remove the lock screw securing the lower arm.</p>	<p>Lock screw, M16x120</p>  <p>xx1200001115</p>

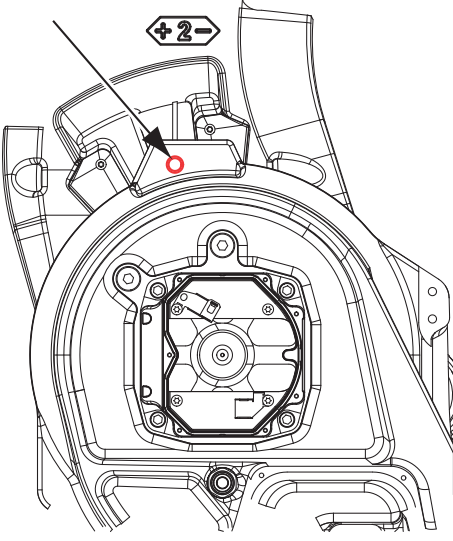
Continues on next page

	Action	Note
3	<p><i>Foundry Plus:</i> Apply Mercasol in the hole for the lock screw.</p>	 <p>xx140000372</p>
4	Refill the gearbox with oil.	See Filling oil into the axis-2 gearbox on page 156 .
5	Re-calibrate the robot.	<p>Pendulum Calibration is described in <i>Operating manual - Calibration Pendulum</i>, enclosed with the calibration tools.</p> <p>Axis Calibration is described in Calibrating with Axis Calibration method on page 781.</p> <p>General calibration information is included in section Calibration on page 767.</p>
6	 <p>DANGER</p> <p>Make sure all safety requirements are met when performing the first test run.</p>	

4 Repair

4.7.3 Replacing the axis-3 motor

4.7.3 Replacing the axis-3 motor

Location of the axis-3 motor

The axis-3 motor is located as shown in the figure.

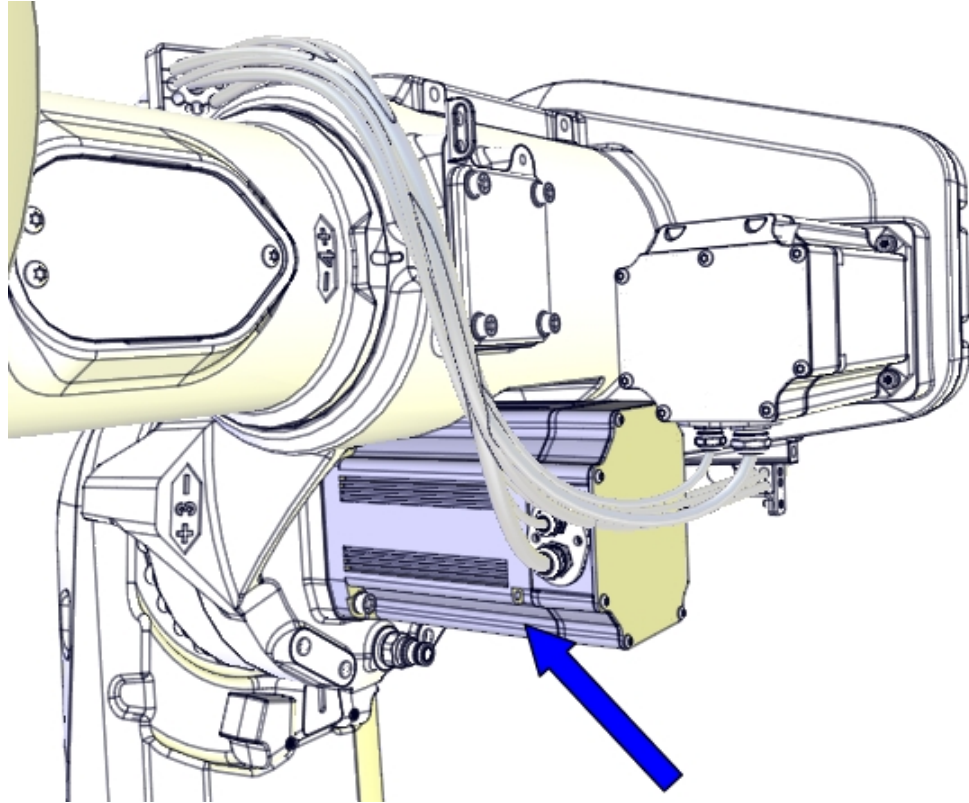

xx1200001113

Spare part

Spare part	Spare part number	Note
Axis-3 motor	See <i>Product manual, spare parts - IRB 6700/IRB 6700Inv.</i> <i>Product manual, spare parts - IRB 6790</i>	

Consumables

Equipment, etc.	Article number	Note
Grease	3HAC042536-001	Shell Gadus S2 Used to lubricate o-rings.
O-ring ⁱ	3HAB3772-111 (circular profile) / 3HAC054692-002 (hexagon profile)	D=169.5x3 Used on motor cover.
O-ring	3HAB3772-107	D=102x3 Used on motor flange.

ⁱ The cross-section profile is either circular or hexagon. If only ordering the o-ring, order the same profile that is currently installed in the connection box.

Continues on next page

Required tools and equipment

Equipment, etc.	Article number	Note
Lifting accessory (chain)	3HAC15556-1	Lifting instruction 3HAC15880-2 enclosed.
Lifting accessory, motor	3HAC15534-1	Lifting instruction 3HAC15640-2 enclosed.
Roundsling, 1 m	-	Length: 1 m, lifting capacity: 1,000 kg.
Removal tool kit M12 and M14	3HAC057339-002	Used to push out the motor, if necessary. Always use removal tools in pairs. Size depending on motor type, see Type A vs type B motors on page 805 .
Guide pin, M10x150	3HAC15521-2	Always use guide pins in pairs.
Bits extender	3HAC12342-1	300 mm, bits 1/2"
Rotation tool	3HAB7887-1	Used to rotate the motor pinion.
24 VDC power supply	-	Used to release the motor brakes.
Leak-down tester	-	
Calibration Pendulum toolkit	3HAC15716-1	Required if Calibration Pendulum is the valid calibration method for the robot.
Calibration tool box, Axis Calibration	3HAC055412-001	Delivered as a set of calibration tools. Required if Axis Calibration is the valid calibration method for the robot.
Standard toolkit	-	Content is defined in section Standard toolkit on page 814 .

Deciding calibration routine

Decide which calibration routine to be used, based on the information in the table. Depending on which routine is chosen, action might be required prior to beginning the repair work of the robot, see the table.

	Action	Note
1	Decide which calibration routine to use for calibrating the robot. <ul style="list-style-type: none"> Reference calibration. External cable packages (DressPack) and tools can stay fitted on the robot. Fine calibration. All external cable packages (DressPack) and tools must be removed from the robot. 	
	<p>If the robot is to be calibrated with reference calibration:</p> <p>Find previous reference values for the axis or create new reference values. These values are to be used after the repair procedure is completed, for calibration of the robot.</p> <p>If no previous reference values exist, and no new reference values can be created, then reference calibration is not possible.</p>	<p>Follow the instructions given in the reference calibration routine on the FlexPendant to create reference values.</p> <p>Creating new values requires possibility to move the robot.</p> <p>Read more about reference calibration for Axis Calibration in Reference calibration routine on page 782.</p> <p>Read more about reference calibration for Pendulum Calibration in <i>Operating manual - Calibration Pendulum</i>.</p>

Continues on next page

4 Repair

4.7.3 Replacing the axis-3 motor

Continued

Action	Note
If the robot is to be calibrated with fine calibration: Remove all external cable packages (DressPack) and tools from the robot.	

Removing the motor

These procedures describes how to remove the motor.

Preparations before removing the axis-3 motor

Use this procedure to do the necessary preparations before removing the motor.

Action	Note
1 Decide which calibration routine to use, and take actions accordingly prior to beginning the repair procedure.	
2 Drain the axis-3 gearbox.	See Draining the axis-3 gearbox on page 160 .
3 Unload the upper arm using one of these methods: <ul style="list-style-type: none">• Use caution and jog axis-3 to maximum + position. Release the brakes and let the upper arm rest against the axis-3 damper.• Use a fork lift to rest the upper arm onto.• Use lifting slings and an overhead crane to rest the upper arm onto.	
4  DANGER Turn off all: <ul style="list-style-type: none">• electric power supply• hydraulic pressure supply• air pressure supply to the robot, before entering the safeguarded space.	
5 Remove any equipment hindering access to the motor.	

Disconnecting the motor cables

Action	Note
1  DANGER Make sure that all supplies for electrical power, hydraulic pressure, and air pressure are turned off.	

Continues on next page

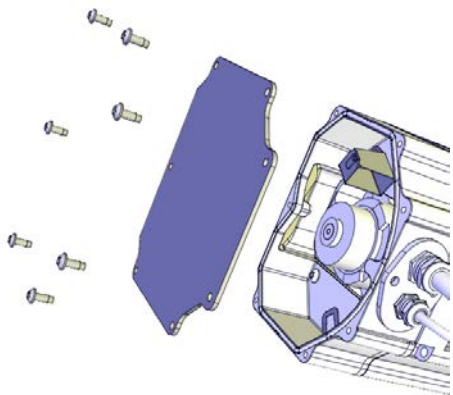
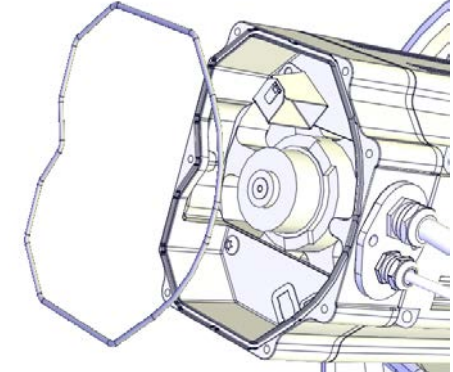
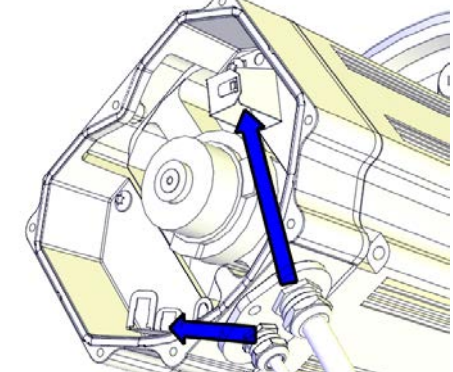
	Action	Note
2	Unscrew the attachment screws and washers and remove the motor cover.	 <p>xx1200001135</p>
3	Make sure the o-ring is present.	 <p>xx1200001070</p>
4	Disconnect the motor cables.	 <p>xx1200001066</p>

Continues on next page

4 Repair

4.7.3 Replacing the axis-3 motor



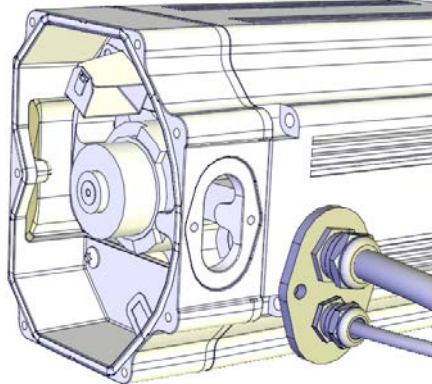

Continued

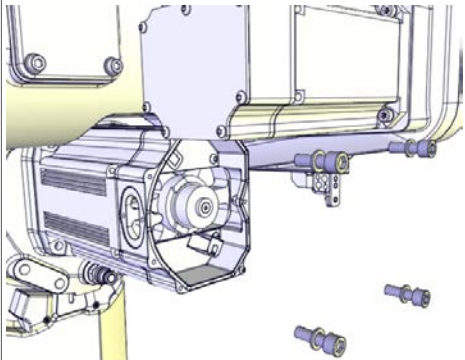
	Action	Note
5	<p>Remove the cable gland cover. Make sure the gasket is not damaged.</p> <p> Tip</p> <p>Make a note in which direction the cable gland hole is facing, if the motor will be removed too. The motor shall be refitted in the same position.</p>	 <p>xx1200001067</p>
6	Use caution and pull out the motor cables.	

Removing the axis-3 motor

	Action	Note
1	Before removing the motor, make sure that the axis-3 gearbox is completely drained.	
2	<p> DANGER</p> <p>When releasing the holding brakes of the motor, the upper arm will be movable and may fall down if not secured. Verify that the upper arm is secured as previously described, before continuing.</p>	
3	<p>To release the brakes, connect the 24 VDC power supply.</p> <p>Connect to connector R2.MP3:</p> <ul style="list-style-type: none"> • + = pin 2 • - = pin 5 	
4	<p>Unscrew the attachment screws that hold the motor.</p> <p>Use a bits extender to reach the screws.</p>	<p>Bits extender: 3HAC12342-1</p>  <p>xx1200001126</p>

Continues on next page

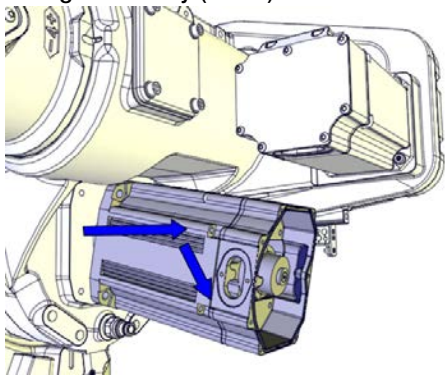
	Action	Note
5	<p>Fit guide pins in opposite holes.</p>  Tip Lubricate the guide pins with some grease to make the motor slide better.	<p>Guide pin, M10x150: 3HAC15521-2 Always use guide pins in pairs.</p>
6	 CAUTION Whenever parting/mating motor and gear-box, the gears may be damaged if excessive force is used.	
7	<p>If required, press the motor out of position by using the removal tool in the remaining holes for the motor.</p>	<p>Removal tool kit M12 and M14: 3HAC057339-002 Removal tool kit M12 and M14: 3HAC057339-002 Depending on motor type A or B, see Identifying the motor by article number on page 805 Always use removal tools in pairs.</p>
8	<p>Use caution and lift the motor out on the guide pins, in order to get the pinion away from the gear, and let the motor rest on the guide pins.</p>	
9	 CAUTION The motor weighs 26 kg. All lifting accessories used must be sized accordingly.	
10	<p>Fasten the lifting accessory to the motor. Attach the lifting chain to the accessory and an overhead crane.</p>	<p>Lifting accessory, motor: 3HAC15534-1 Lifting accessory (chain): 3HAC15556-1</p>
11	<p>When the motor is hanging in the lifting accessory, and the pinion no longer is mated to the gear, let the outer end of the motor hang lower so that it will hang in an angle. This position makes it easier to remove the axis-3 motor with the axis-4 motor still fitted.</p>  CAUTION The pinion must have been parted from the gear before the motor is angled. If not there is a risk of damaging the pinion and gear.	
12	<p>Disconnect the 24 VDC power supply.</p>	

Continues on next page

4 Repair

4.7.3 Replacing the axis-3 motor

Continued

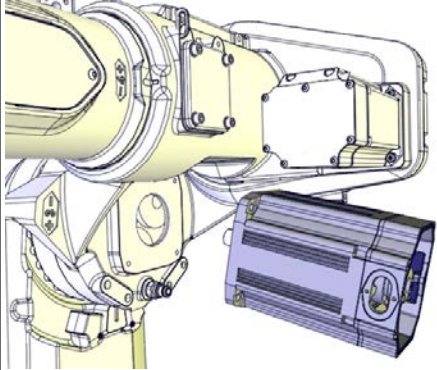
	Action	Note
13	Remove the motor by lifting it straight out.	Make sure the pinion is not damaged.  xx1200001131

Refitting the motor

These procedures describes how to refit the motor.

Preparations prior to refitting motor

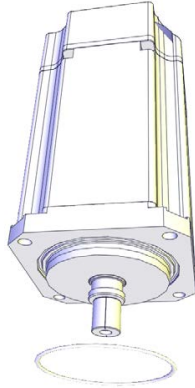
	Action	Note
1	 DANGER Make sure that all supplies for electrical power, hydraulic pressure, and air pressure are turned off.	
2	Remove any old paint residues or other contamination from the contact surfaces on both the motor and the mating parts. Wipe clean the contact surfaces and the o-ring groove.	
3	Fit a new o-ring.	 xx1200001019

Continues on next page

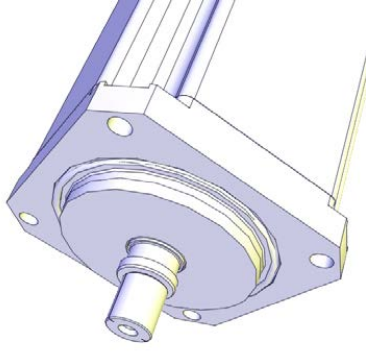
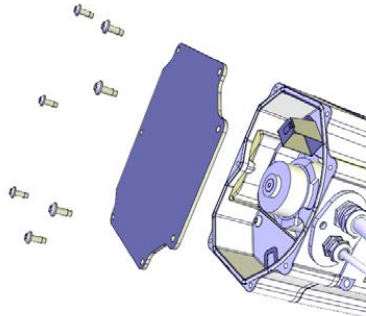
	Action	Note
4	<p>Make sure the o-ring is seated in the groove.</p> <p> Tip</p> <p>Lubricate the o-ring with some grease for a better fitting in the groove.</p>	 <p>xx1200001020</p>
5	<p>If the motor is a new spare part, remove the cover.</p>	 <p>xx1200001135</p>

Securing the axis-3 motor

Use this procedure to secure the motor.



	Action	Note
1	<p>Fit guide pins in opposite holes.</p>	<p>Guide pin, M10x150: 3HAC15521-2 Always use guide pins in pairs.</p>
2	<p> CAUTION</p> <p>The motor weighs 26 kg. All lifting accessories used must be sized accordingly.</p>	

Continues on next page

4 Repair

4.7.3 Replacing the axis-3 motor

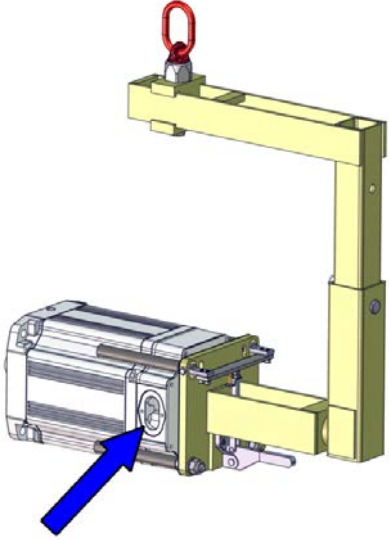
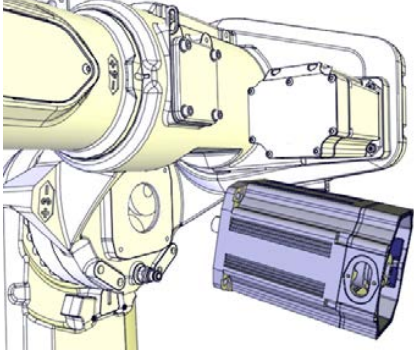

Continued

	Action	Note
3	<p>Apply the lifting accessories to the motor.</p> <p> Note</p> <p>Make sure the cable gland exit is turned according to figure.</p>	<p>Lifting accessory, motor: 3HAC15534-1</p>  <p>xx1700000273</p>
4	<p>Lift the motor on to the guide pins and let it hang with the outer end a little lower when resting on the guide pins. Do not push the motor pinion into the gear yet.</p> <p>This is done in order to fit the motor with the axis-4 motor still fitted.</p>	 <p>xx1200001131</p>
5	<p>Remove the lifting accessory and allow the motor to rest on the guide pins.</p>	
6	<p>Apply the rotation tool and use it to rotate the pinion when mating it into the gear.</p>	<p>Rotation tool: 3HAB7887-1</p>
7	<p>To release the brakes, connect the 24 VDC power supply.</p> <p>Connect to connector R2.MP3:</p> <ul style="list-style-type: none"> • + = pin 2 • - = pin 5 	
8	<p> CAUTION</p> <p>Whenever parting/mating motor and gearbox, the gears may be damaged if excessive force is used.</p>	

Continues on next page

	Action	Note
9	Use caution and push the motor in position while at the same time the motor pinion is slightly rotated. Pay attention to following points: <ul style="list-style-type: none"> • Mate the motor pinion properly to the gear of the gearbox. • Do not damage the motor pinion. 	
10	Fit two of the attachment screws and washers.	Screws: M10x30 quality 12.9 Gleitmo
11	Remove the guide pins.	
12	Fit the remaining attachment screws and washers.	Screws: M10x30 quality 12.9 Gleitmo
13	Tighten the screws.	Tightening torque: 50 Nm
14	Remove the rotation tool.	
15	Perform a leak-down test.	See Performing a leak-down test on page 186 .
16	Disconnect the 24 VDC power supply.	

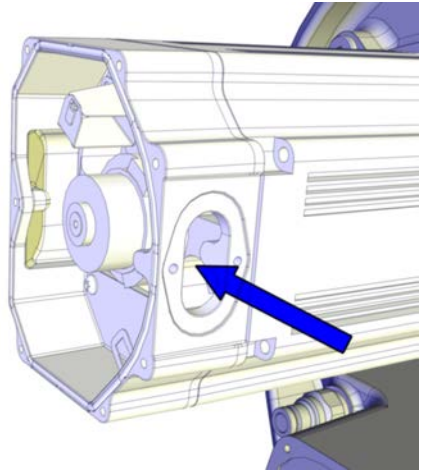
Connecting the motor cables

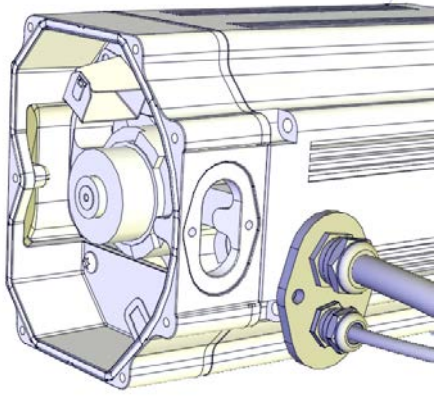



	Action	Note
1	Push the motor cables through the cable gland opening.	 xx130000738
2	Refit the cable gland cover.  Note Replace the gasket if damaged.	 xx1200001067

Continues on next page

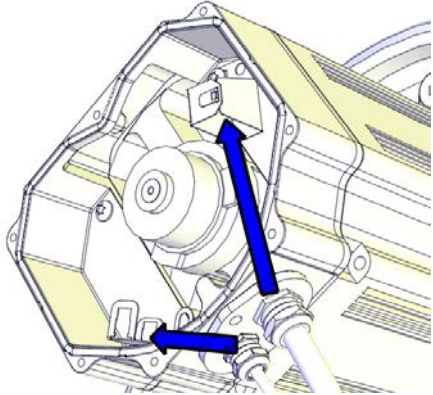

4 Repair

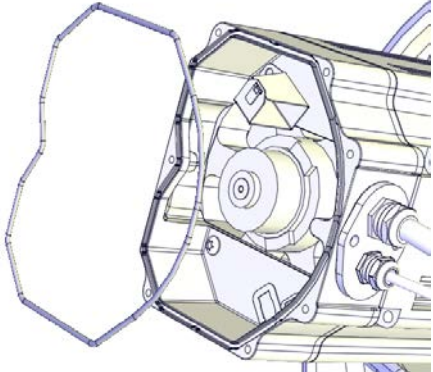
4.7.3 Replacing the axis-3 motor

Continued

	Action	Note
3	Connect the motor cables. Connect in accordance with the markings on the connectors.	 xx1200001066
4	Inspect the o-ring.  Note Replace if damaged.	O-ring, axis-1: 3HAB3772-111 (circular profile) / 3HAC054692-002 (hexagon profile) O-ring, axis-2: 3HAB3772-111 (circular profile) / 3HAC054692-002 (hexagon profile) O-ring, axis-3: 3HAB3772-111 (circular profile) / 3HAC054692-002 (hexagon profile) O-ring, axis-4: 3HAB3772-110 (circular profile) / 3HAC054692-001 (hexagon profile)  xx1200001070
5	Wipe clean o-ring and o-ring groove.	
6	Refit the o-ring.  Tip Lubricate the o-ring with some grease for a better fitting in the groove.	
7	 CAUTION When fitting the motor cover, make sure that none of the cables inside will be damaged.	

Continues on next page

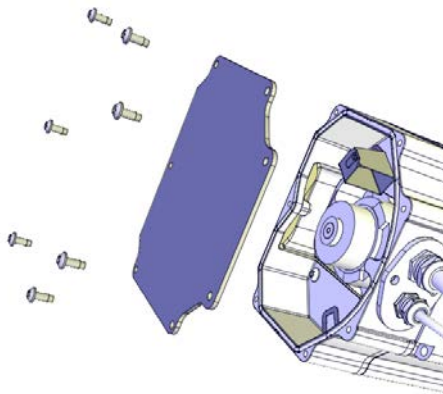
	Action	Note
8	<p>Refit the motor cover with it's attachment screws.</p> <p> Note</p> <p>Do not reuse the self-threading attachment screws. Replace with standard attachment screws or the threads will be damaged.</p> <p> Note</p> <p>Make sure the o-ring is undamaged and properly fitted.</p>	<p>Attachment screws: M5x12 8.8 (7 pcs)</p>  <p>xx1200001135</p>
9	<p>Make sure that the covers are tightly sealed.</p>	

Concluding procedure

Use this procedure for the concluding refitting.

	Action	Note
1	<p>Remove the equipment used to unload the upper arm.</p>	
2	<p>Refill the gearbox with oil.</p>	<p>See Filling oil into the axis-3 gearbox on page 161.</p>
3	<p>Re-calibrate the robot.</p>	<p>Pendulum Calibration is described in Operating manual - Calibration Pendulum, enclosed with the calibration tools.</p> <p>Axis Calibration is described in Calibrating with Axis Calibration method on page 781.</p> <p>General calibration information is included in section Calibration on page 767.</p>
4	<p> DANGER</p> <p>Make sure all safety requirements are met when performing the first test run.</p>	

4 Repair

4.7.4 Replacing the axis-4 motor

4.7.4 Replacing the axis-4 motor

Location of the axis-4 motor

The axis-4 motor is located as shown in the figure.

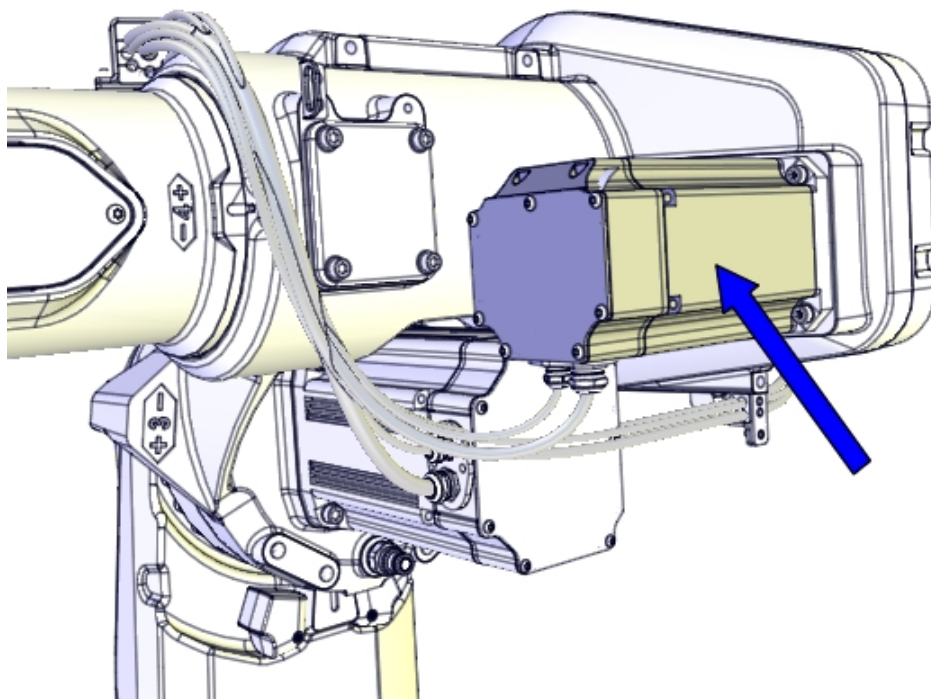

xx1200001114

Spare parts

Spare part	Spare part number	Note
Axis-4 motor	See <i>Product manual, spare parts - IRB 6700/IRB 6700Inv.</i> <i>Product manual, spare parts - IRB 6790</i>	

Consumables

Equipment, etc.	Article number	Note
Grease	3HAC042536-001	Shell Gadus S2 Used to lubricate o-rings.
O-ring ⁱ	3HAB3772-110 (circular profile) / 3HAC054692-001 (hexagon profile)	D=119x3 Used on motor cover.
O-ring	3HAB3772-107	D=102x3 Used on motor flange.

ⁱ The cross-section profile is either circular or hexagon. If only ordering the o-ring, order the same profile that is currently installed in the connection box.

Continues on next page

Required tools and equipment

Equipment, etc.	Article number	Note
Removal tool kit M12 and M14	3HAC057339-002	Used to push out the motor, if necessary. Always use removal tools in pairs.
Guide pin, M8x150	3HAC15520-2	Always use guide pins in pairs.
Long AllenKeySocketIN19L 6-140	-	Length: 140 mm.
Rotation tool	3HAB7887-1	Used to rotate the motor pinion.
24 VDC power supply	-	Used to release the motor brakes.
Leak-down tester	-	
Calibration Pendulum toolkit	3HAC15716-1	Required if Calibration Pendulum is the valid calibration method for the robot.
Calibration tool box, Axis Calibration	3HAC055412-001	Delivered as a set of calibration tools. Required if Axis Calibration is the valid calibration method for the robot.
Standard toolkit	-	Content is defined in section Standard toolkit on page 814 .

Deciding calibration routine

Decide which calibration routine to be used, based on the information in the table. Depending on which routine is chosen, action might be required prior to beginning the repair work of the robot, see the table.

	Action	Note
1	Decide which calibration routine to use for calibrating the robot. <ul style="list-style-type: none"> Reference calibration. External cable packages (DressPack) and tools can stay fitted on the robot. Fine calibration. All external cable packages (DressPack) and tools must be removed from the robot. 	
	<p>If the robot is to be calibrated with reference calibration:</p> <p>Find previous reference values for the axis or create new reference values. These values are to be used after the repair procedure is completed, for calibration of the robot.</p> <p>If no previous reference values exist, and no new reference values can be created, then reference calibration is not possible.</p>	<p>Follow the instructions given in the reference calibration routine on the FlexPendant to create reference values.</p> <p>Creating new values requires possibility to move the robot.</p> <p>Read more about reference calibration for Axis Calibration in Reference calibration routine on page 782.</p> <p>Read more about reference calibration for Pendulum Calibration in <i>Operating manual - Calibration Pendulum</i>.</p>
	<p>If the robot is to be calibrated with fine calibration:</p> <p>Remove all external cable packages (DressPack) and tools from the robot.</p>	

Continues on next page

4 Repair

4.7.4 Replacing the axis-4 motor

Continued

Removing the motor

These procedures describes how to remove the motor.

Preparations before removing the axis-4 motor

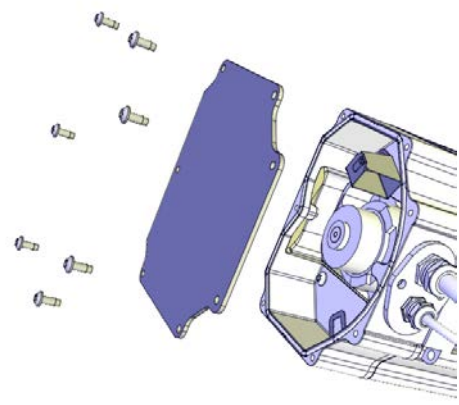

	Action	Note
1	Decide which calibration routine to use, and take actions accordingly prior to beginning the repair procedure.	
2	Jog the robot into position: <ul style="list-style-type: none"> axis 1 = no significance. axis 2 = -65° axis 3 = upper arm pointing straight up (if possible). With the robot in this position, there is no need to drain oil from the axis-4 gearbox when the motor is replaced.	
3	If there is no space to position the upper arm pointed straight up, drain the axis-4 gearbox.	
4	 DANGER Turn off all: <ul style="list-style-type: none"> electric power supply hydraulic pressure supply air pressure supply to the robot, before entering the safe-guarded space.	

Disconnecting the motor cables

	Action	Note
1	 DANGER Make sure that all supplies for electrical power, hydraulic pressure, and air pressure are turned off.	
2	Unscrew the attachment screws and washers and remove the motor cover.	 <p>xx1200001135</p>

Continues on next page

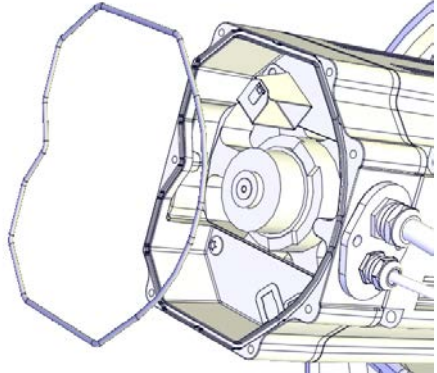
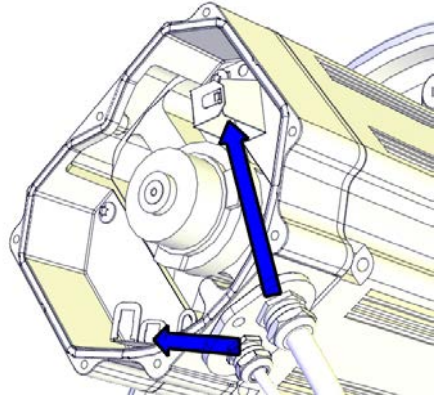
4.7.4 Replacing the axis-4 motor
Continued

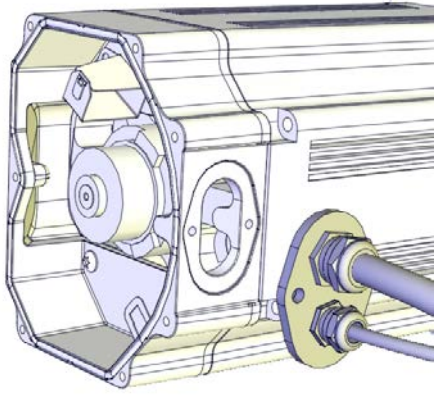
	Action	Note
3	Make sure the o-ring is present.	 <p>xx1200001070</p>
4	Disconnect the motor cables.	 <p>xx1200001066</p>
5	<p>Remove the cable gland cover. Make sure the gasket is not damaged.</p> <p> Tip</p> <p>Make a note in which direction the cable gland hole is facing, if the motor will be removed too. The motor shall be refitted in the same position.</p>	 <p>xx1200001067</p>
6	Use caution and pull out the motor cables.	

Removing the axis-4 motor



	Action	Note
1	<p> CAUTION</p> <p>Use caution when releasing the brakes! Axis-4 can move unexpectedly!</p>	

Continues on next page

4 Repair

4.7.4 Replacing the axis-4 motor

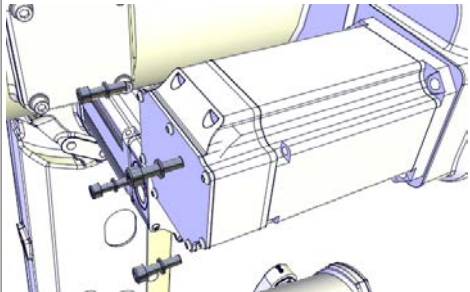
Continued

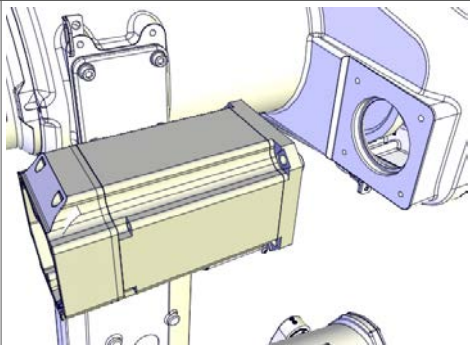

	Action	Note
2	To release the brakes, connect the 24 VDC power supply. Connect to connector R2.MP4: <ul style="list-style-type: none">• + = pin 2• - = pin 5	
3	Unscrew the attachment screws that secure the motor.	 xx1200001137
4	Apply two guide pins in opposite holes.	Guide pin, M8x150: 3HAC15520-2 Always use guide pins in pairs.
5	 CAUTION Whenever parting/mating motor and gear-box, the gears may be damaged if excessive force is used.	
6	Press the motor out of position by fitting the removal tool in the remaining attachment holes for the motor.	Removal tool kit M12 and M14: 3HAC057339-002 Always use removal tools in pairs.
7	 CAUTION The motor weighs 13 kg. All lifting accessories used must be sized accordingly.	
8	Disconnect the 24 VDC power supply.	
9	Remove the motor by carefully lifting it straight out/straight up (if the upper arm points upwards). Make sure the pinion is not damaged.	 xx1200001138

Continues on next page

Refitting the motor

These procedures describes how to refit the motor.

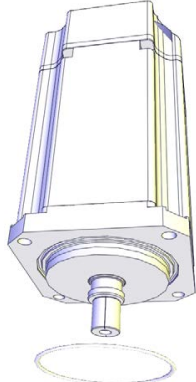
Preparations prior to refitting motor

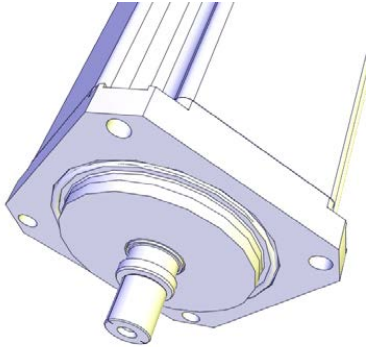
	Action	Note
1	 <p>DANGER</p> <p>Make sure that all supplies for electrical power, hydraulic pressure, and air pressure are turned off.</p>	
2	<p>Remove any old paint residues or other contamination from the contact surfaces on both the motor and the mating parts.</p> <p>Wipe clean the contact surfaces and the o-ring groove.</p>	
3	<p>Fit a new o-ring.</p>	 <p>xx1200001019</p>
4	 <p>Tip</p> <p>Lubricate the o-ring with some grease for a better fitting in the groove.</p>	 <p>xx1200001020</p>

Continues on next page

4 Repair

4.7.4 Replacing the axis-4 motor

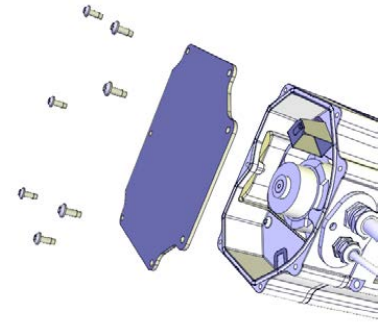

Continued

	Action	Note
5	If the motor is a new spare part, remove the cover.	 xx1200001135

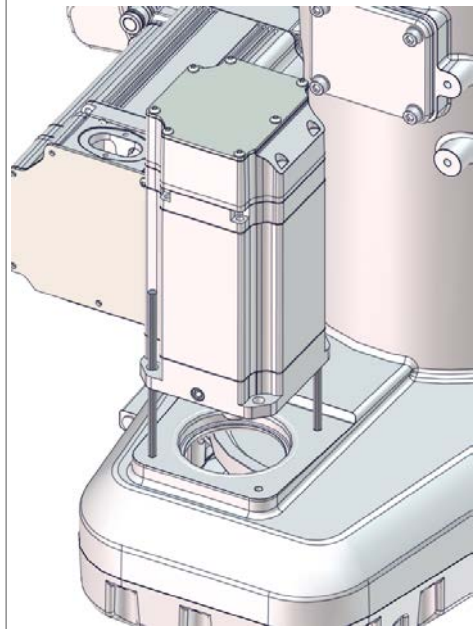
Securing the axis-4 motor

	Action	Note
1	Apply two guide pins in opposite holes.	Guide pin, M8x150: 3HAC15520-2 Always use guide pins in pairs.
2	Put the motor onto the guide pins.	 xx1700000291

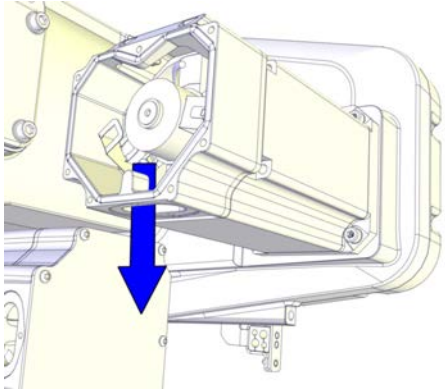
Continues on next page

	Action	Note
3	 Note Make sure the cable gland opening is turned the correct way.	 <small>xx1200001130</small>
4	 CAUTION The motor weighs 13 kg. All lifting accessories used must be sized accordingly.	
5	Apply the rotation tool and use it to rotate the pinion when mating it into the gear. This requires two persons co-operating, if the motor is installed from above (if the upper arm is pointing upwards).	Rotation tool: 3HAB7887-1
6	To release the brakes, connect the 24 VDC power supply. Connect to connector R2.MP2: <ul style="list-style-type: none"> • + = pin 2 • - = pin 5 	
7	 CAUTION Whenever parting/mating motor and gearbox, the gears may be damaged if excessive force is used.	
8	Push the motor carefully in position while at the same time rotating the motor pinion slightly. <ul style="list-style-type: none"> • Make sure that the motor pinion is properly mated to the gear of the gearbox. • Make sure that the motor pinion does not get damaged. • Make sure that the direction of the cable gland is facing the correct way. 	
9	Remove the guide pins.	

Continues on next page



4 Repair

4.7.4 Replacing the axis-4 motor

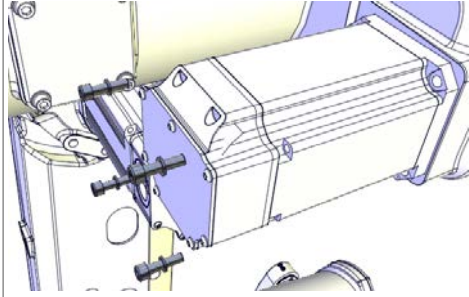

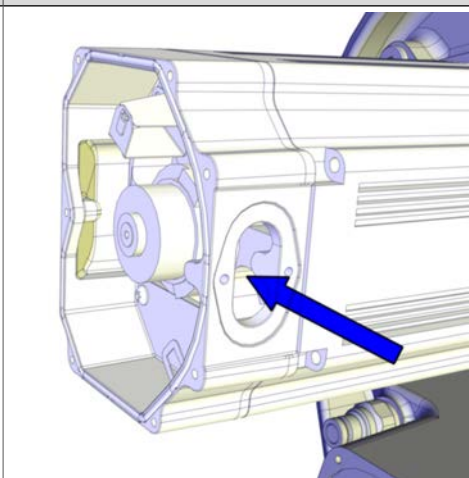

Continued

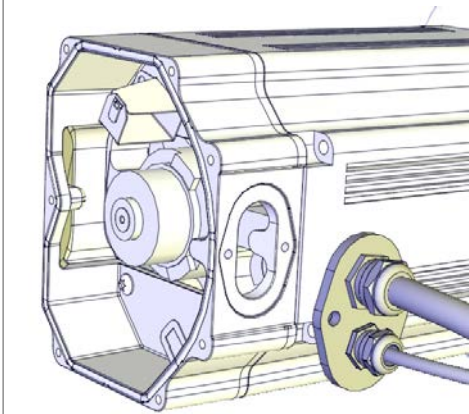
	Action	Note
10	Secure the motor with its attachment screws and washers.	Tightening torque: 35 Nm. Screws: M8x30 quality 12.9 Gleitmo (4 pcs)  xx1200001137
11	Perform a leak-down test.	See Performing a leak-down test on page 186 .
12	Disconnect the 24 VDC power supply.	

Connecting the motor cables

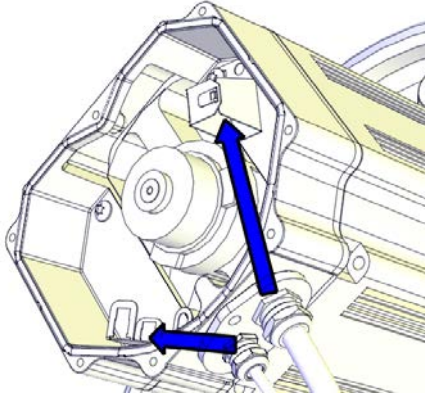
	Action	Note
1	Push the motor cables through the cable gland opening.	 xx1300000738
2	Refit the cable gland cover.  Note Replace the gasket if damaged.	 xx1200001067

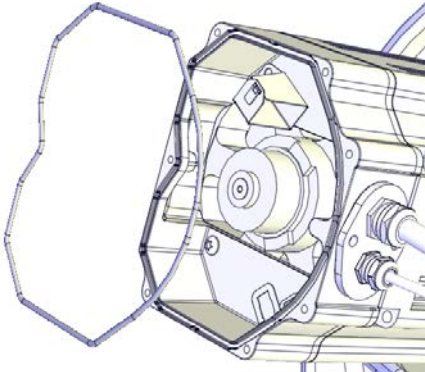
Continues on next page



	Action	Note
3	<p>Connect the motor cables. Connect in accordance with the markings on the connectors.</p>	 <p>xx1200001066</p>
4	<p>Inspect the o-ring.</p> <p> Note Replace if damaged.</p>	<p>O-ring, axis-1: 3HAB3772-111 (circular profile) / 3HAC054692-002 (hexagon profile) O-ring, axis-2: 3HAB3772-111 (circular profile) / 3HAC054692-002 (hexagon profile) O-ring, axis-3: 3HAB3772-111 (circular profile) / 3HAC054692-002 (hexagon profile) O-ring, axis-4: 3HAB3772-110 (circular profile) / 3HAC054692-001 (hexagon profile)</p>  <p>xx1200001070</p>
5	<p>Wipe clean o-ring and o-ring groove.</p>	
6	<p>Refit the o-ring.</p> <p> Tip Lubricate the o-ring with some grease for a better fitting in the groove.</p>	
7	<p> CAUTION When fitting the motor cover, make sure that none of the cables inside will be damaged.</p>	

Continues on next page

4 Repair

4.7.4 Replacing the axis-4 motor

Continued

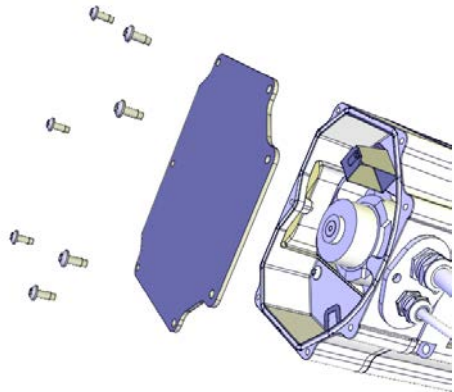
	Action	Note
8	<p>Refit the motor cover with it's attachment screws.</p> <p> Note</p> <p>Do not reuse the self-threading attachment screws. Replace with standard attachment screws or the threads will be damaged.</p> <p> Note</p> <p>Make sure the o-ring is undamaged and properly fitted.</p>	<p>Attachment screws: M5x12 8.8 (7 pcs)</p>  <p>xx1200001135</p>
9	<p>Make sure that the covers are tightly sealed.</p>	

Concluding procedure

	Action	Note
1	<p>Refill the gearbox with oil, if gearbox has been drained.</p>	<p>See Filling oil into the axis-4 gearbox on page 167.</p>
2	<p>Re-calibrate the robot.</p>	<p>Pendulum Calibration is described in <i>Operating manual - Calibration Pendulum</i>, enclosed with the calibration tools.</p> <p>Axis Calibration is described in Calibrating with Axis Calibration method on page 781.</p> <p>General calibration information is included in section Calibration on page 767.</p>
3	<p> DANGER</p> <p>Make sure all safety requirements are met when performing the first test run.</p>	

4.7.5 Replacing the axis-5 motor

Location of the axis-5 motor

The axis-5 motor is located inside the wrist, as shown in the figure.

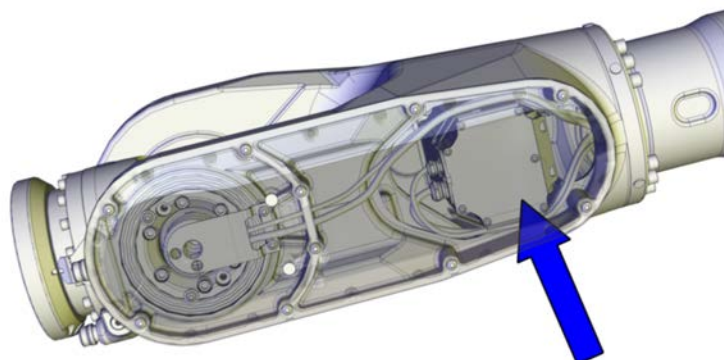

xx1500001899

Spare part

Spare part	Spare part number	Note
Axis-5 motor	See <i>Product manual, spare parts - IRB 6700/IRB 6700Inv.</i> <i>Product manual, spare parts - IRB 6790</i>	
Heat protection plate	See <i>Product manual, spare parts - IRB 6700/IRB 6700Inv.</i> <i>Product manual, spare parts - IRB 6790</i>	Required, if replacing a type A motor with a type B motor. 2 plates required. See Type A vs type B motors on page 805 .

Consumables

Equipment, etc.	Article number	Note
Grease	3HAC042536-001	Shell Gadus S2 Used to lubricate o-rings.
O-ring ⁱ	3HAB3772-110 (circular profile) / 3HAC054692-001 (hexagon profile)	D=119x3 Used on motor cover.
O-ring	3HAB3772-107	D=102x3 Used on motor flange.

ⁱ The cross-section profile is either circular or hexagon. If only ordering the o-ring, order the same profile that is currently installed in the connection box.

Required tools

Equipment, etc.	Article number	Note
Removal tool kit M12 and M14	3HAC057339-002	Used to push out the motor, if necessary. Always use removal tools in pairs.

Continues on next page

4 Repair

4.7.5 Replacing the axis-5 motor

Continued

Equipment, etc.	Article number	Note
Long AllenKeySocketIN19L 6-140	-	Length: 140 mm.
Guide pin, M8x100	3HAC15520-1	Always use guide pins in pairs.
Rotation tool	3HAB7887-1	Used to rotate the motor pinion.
24 VDC power supply	-	Used to release the motor brakes.
Leak-down tester	-	
Calibration Pendulum toolkit	3HAC15716-1	Required if Calibration Pendulum is the valid calibration method for the robot.
Calibration tool box, Axis Calibration	3HAC055412-001	Delivered as a set of calibration tools. Required if Axis Calibration is the valid calibration method for the robot.
Standard toolkit	-	Content is defined in section Standard toolkit on page 814 .

Deciding calibration routine

Decide which calibration routine to be used, based on the information in the table. Depending on which routine is chosen, action might be required prior to beginning the repair work of the robot, see the table.



	Action	Note
1	<p>Decide which calibration routine to use for calibrating the robot.</p> <ul style="list-style-type: none"> Reference calibration. External cable packages (DressPack) and tools can stay fitted on the robot. Fine calibration. All external cable packages (DressPack) and tools must be removed from the robot. 	
	<p>If the robot is to be calibrated with reference calibration:</p> <p>Find previous reference values for the axis or create new reference values. These values are to be used after the repair procedure is completed, for calibration of the robot.</p> <p>If no previous reference values exist, and no new reference values can be created, then reference calibration is not possible.</p>	<p>Follow the instructions given in the reference calibration routine on the FlexPendant to create reference values.</p> <p>Creating new values requires possibility to move the robot.</p> <p>Read more about reference calibration for Axis Calibration in Reference calibration routine on page 782.</p> <p>Read more about reference calibration for Pendulum Calibration in <i>Operating manual - Calibration Pendulum</i>.</p>
	<p>If the robot is to be calibrated with fine calibration:</p> <p>Remove all external cable packages (DressPack) and tools from the robot.</p>	

Continues on next page

Removing the axis-5 motor

Use these procedures to remove the motor.

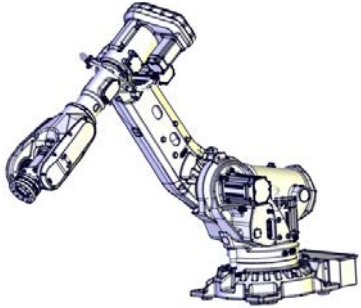
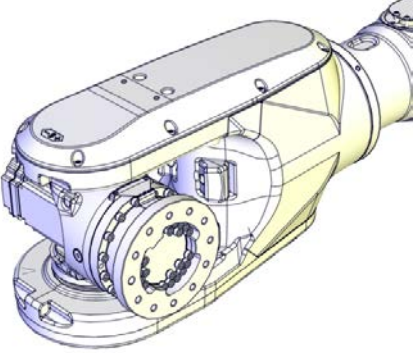
Preparations before removing the axis-5 motor

	Action	Note
1	Decide which calibration routine to use, and take actions accordingly prior to beginning the repair procedure.	
2	Jog the robot to this position: <ul style="list-style-type: none"> • Axis 2: +25° • Axis 3: +35° 	 <p>xx1200001005</p>
3	Jog axis 4 to this position: <ul style="list-style-type: none"> • Axis 4: +90° 	<p>With the robot in this position, there is no need to drain oil from the axis-5 gearbox when the motor is replaced.</p>  <p>xx1400000719</p>
4	 <p>DANGER</p> <p>Turn off all:</p> <ul style="list-style-type: none"> • electric power supply • hydraulic pressure supply • air pressure supply <p>to the robot, before entering the safe-guarded space.</p>	

Continues on next page

4 Repair

4.7.5 Replacing the axis-5 motor

Continued

Retrieving access to the wrist cabling

Use this procedure to remove the wrist cover to retrieve access to the axis-5 and axis-6 motor cables.

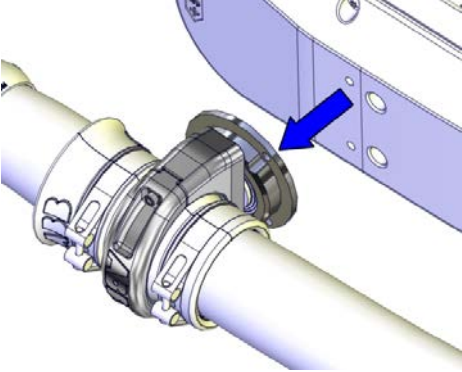
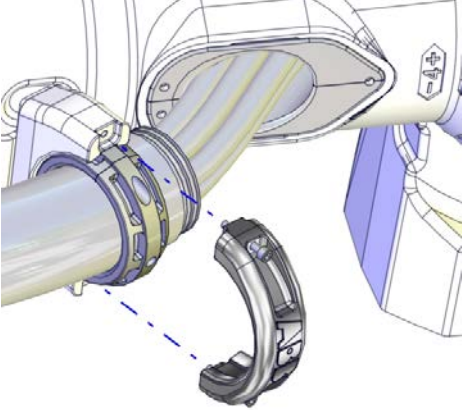
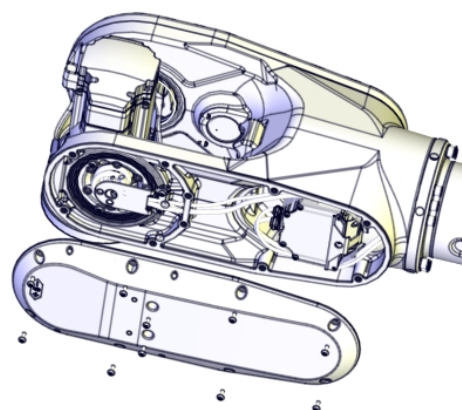
	Action	Note
1	 DANGER Make sure that all supplies for electrical power, hydraulic pressure, and air pressure are turned off.	
2	If DressPack is installed: <ul style="list-style-type: none">Remove the bracket with the complete ball joint housing still fitted, as shown in the figure. This is done to be able to reach the two hidden screws that secure the wrist cover.	 xx140000355
3	If used, open the ball joint housing on the arm tube and remove the DressPack cable package.	 xx140000206
4	Remove the wrist cover.	 xx1300002247

Continues on next page

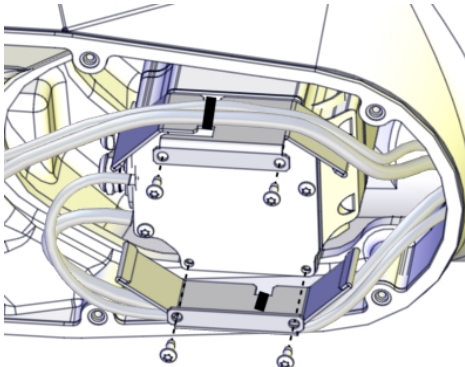
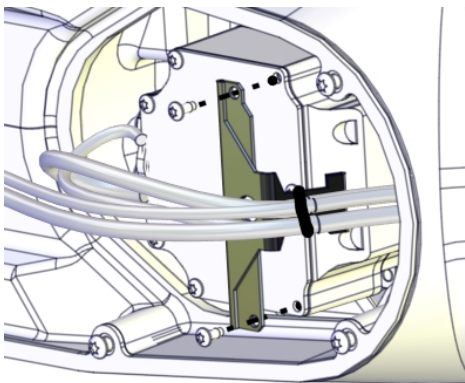

	Action	Note
5	<p>Remove the heat protection plate/plates from the motor with the cabling still attached to the plate.</p> <p>Remove the heat protection plates from the motor with the cabling still attached to the plate.</p>	<p>There are two versions of the heat protection plates.</p> <p>Choose figure depending on which plate is installed on the robot.</p>  <p>xx1500001030</p>  <p>xx1300000490</p>

Continues on next page

4 Repair

4.7.5 Replacing the axis-5 motor

Continued

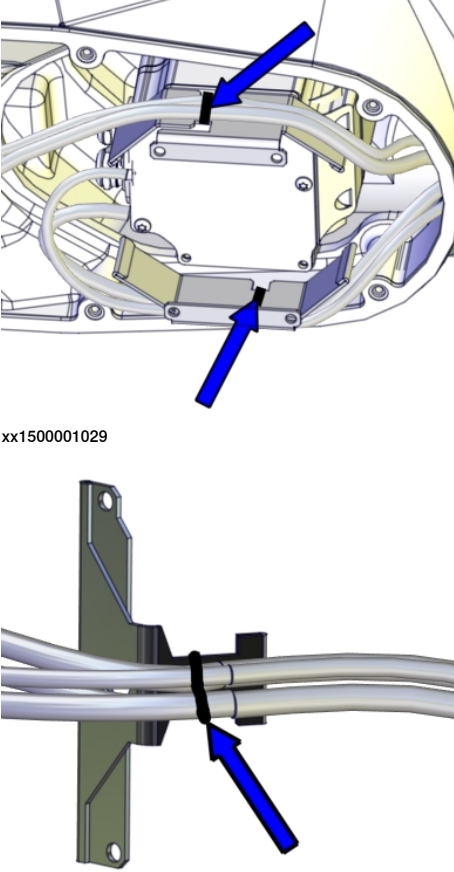
	Action	Note
6	<p>Cut the cable ties that hold the cable harness to the plate.</p> <p> Note</p> <p>Keep the heat protection plate until refitting.</p> <p> Tip</p> <p>If removing the plate only for replacing the motor, the cabling does not need to be loosened from the plate.</p>	<p>Choose figure depending on which plate is installed on the robot.</p>  <p>xx1500001029</p> <p>xx1300000489</p>

Disconnecting the motor cables

	Action	Note
1	<p> DANGER</p> <p>Make sure that all supplies for electrical power, hydraulic pressure, and air pressure are turned off.</p>	

Continues on next page

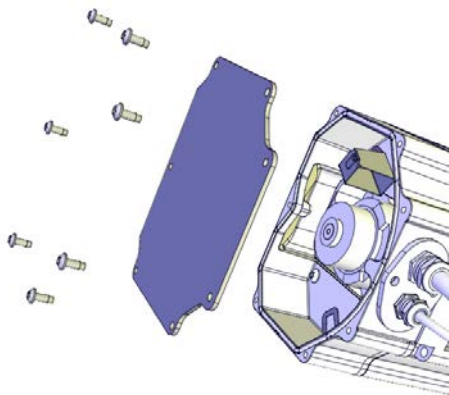
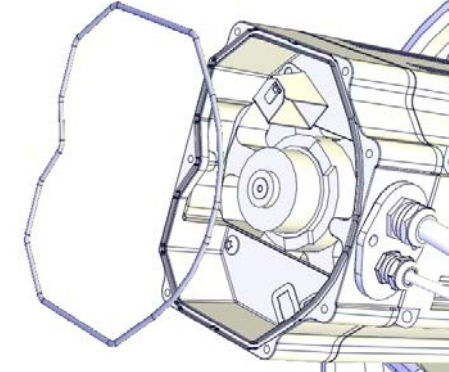
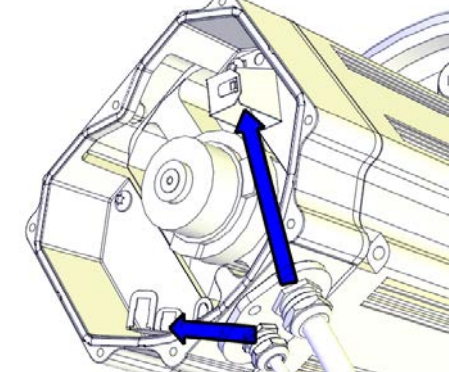
	Action	Note
2	Unscrew the attachment screws and washers and remove the motor cover.	 <p>xx1200001135</p>
3	Make sure the o-ring is present.	 <p>xx1200001070</p>
4	Disconnect the motor cables.	 <p>xx1200001066</p>

Continues on next page



4 Repair

4.7.5 Replacing the axis-5 motor

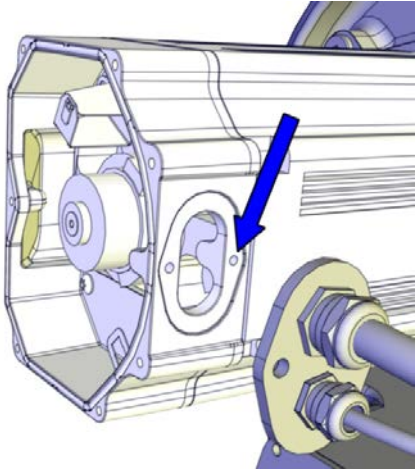
Continued

	Action	Note
5	<p>Remove the cable gland cover by performing the following steps:</p> <ol style="list-style-type: none"> 1 Open the inner screw a little (the one the arrow is pointing at). No need to remove this screw from the motor. 2 Remove the outer screw. 3 Slide the cable gland cover away from the inner screw. Make sure the gasket is not damaged. <p> Tip</p> <p>Make a note in which direction the cable exit hole is facing, if the motor will be removed too. The motor shall be refitted in the same position.</p>	 <p>xx1300000656</p>
6	Use caution and pull out the motor cables.	

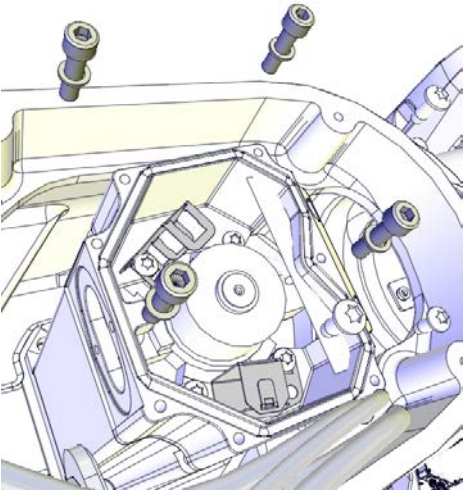
Removing the axis-5 motor

	Action	Note
1	Unscrew the attachment screws that secure the motor, using a bits extender.	<p>Bits extender: 3HAC12342-1</p>  <p>xx1200001017</p>
2	<p> CAUTION</p> <p>Whenever parting/mating motor and gear-box, the gears may be damaged if excessive force is used.</p>	
3	If needed, fit removal tools in opposite holes.	<p>Removal tool kit M12 and M14: 3HAC057339-002</p> <p>Always use removal tools in pairs.</p>

Continues on next page

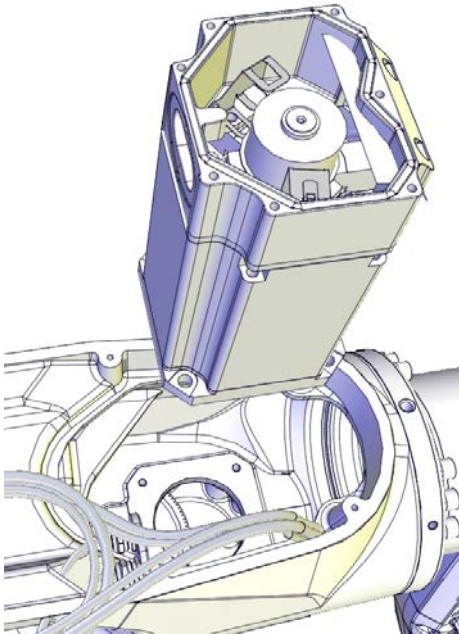
	Action	Note
4	<p> CAUTION</p> <p>The motor weighs 12 kg. All lifting accessories used must be sized accordingly.</p>	
5	<p>Use caution and lift the motor out. Be careful not to damage the pinion.</p>	 <p>xx1200001018</p>

Refitting the axis-5 motor

The procedures describe how to refit the motor.

Preparations before refitting the axis-5 motor

	Action	Note
1	<p> DANGER</p> <p>Turn off all:</p> <ul style="list-style-type: none"> • electric power supply • hydraulic pressure supply • air pressure supply <p>to the robot, before entering the safe-guarded space.</p>	

Continues on next page

4 Repair

4.7.5 Replacing the axis-5 motor

Continued

	Action	Note
2	Wipe clean the contact surfaces from any contamination. Also wipe clean the o-ring groove.	 <p data-bbox="943 949 1050 965">xx1200001019</p>
3	Check the o-ring. Replace if damaged.	O-ring, 3HAB3772-107
4	Lubricate the o-ring with some grease.	
5	Make sure the o-ring is seated in the groove.	 <p data-bbox="943 1581 1050 1597">xx1200001020</p>
6	Apply two guide pins in opposite holes.	Guide pin, M8x100: 3HAC15520-1

Securing the axis-5 motor

	Action	Note
1	 CAUTION Whenever parting/mating motor and gear-box, the gears may be damaged if excessive force is used.	

Continues on next page

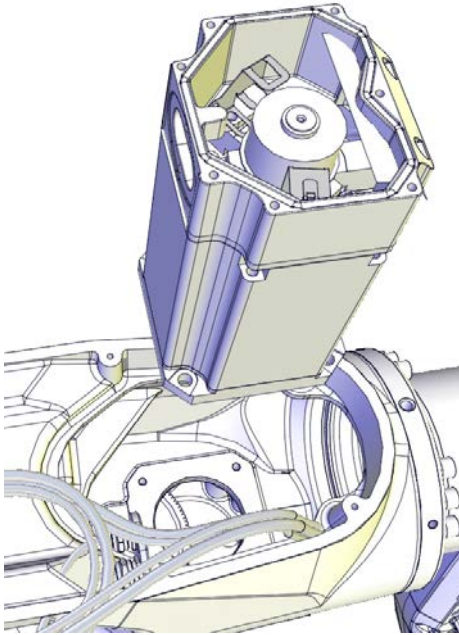
	Action	Note
2	Apply the rotation tool and use it to rotate the pinion when mating it into the gear.	Rotation tool: 3HAB7887-1
3	To release the brakes, connect the 24 VDC power supply. Connect to connector R2.MP5: <ul style="list-style-type: none"> • + = pin 2 • - = pin 5 	24 VDC power supply
4	 CAUTION The motor weighs 12 kg. All lifting accessories used must be sized accordingly.	
5	Use caution and lower the motor into position on the guide pins, while at the same time rotating the motor pinion slightly. Make sure that: <ul style="list-style-type: none"> • the motor pinion is properly mated to the gear of the gearbox. • the motor pinion does not get damaged. • the direction of the cable exit is facing the same way as before removal. 	Rotation tool, 3HAB7887-1  xx1200001018
6	Remove the guide pins.	

Continues on next page

4 Repair

4.7.5 Replacing the axis-5 motor

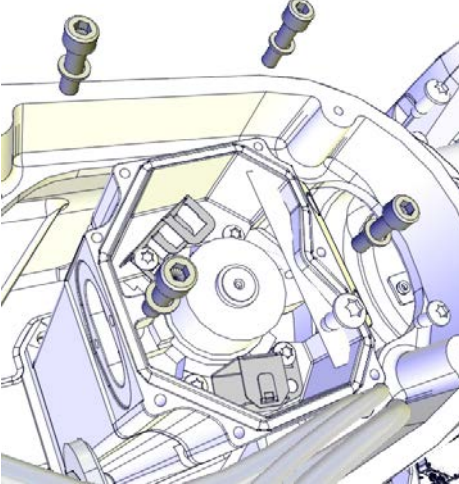

Continued

	Action	Note
7	Secure the motor with its attachment screws and washers.	Tightening torque: 24 Nm. Screw dimension: M8x30 quality 12.9 Gleitmo(4 pcs)  xx1200001017
8	Perform a leak-down test.	See Performing a leak-down test on page 186 .
9	Disconnect the 24 VDC power supply.	

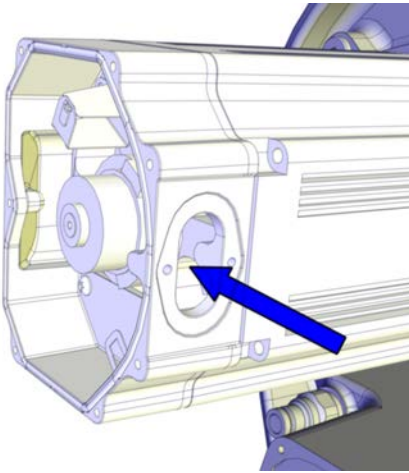
Connecting the motor cables

	Action	Note
1	Push the motor cables in through the cable gland opening.	 xx1300000738

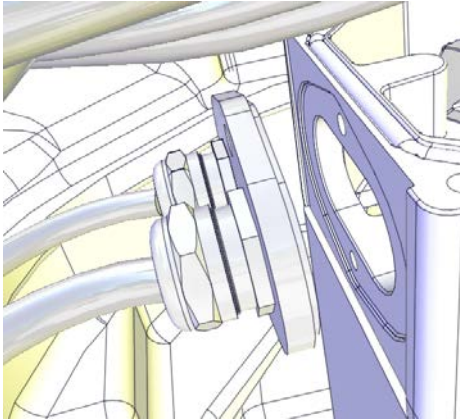
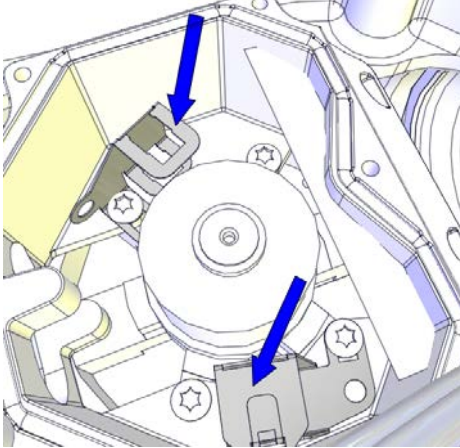
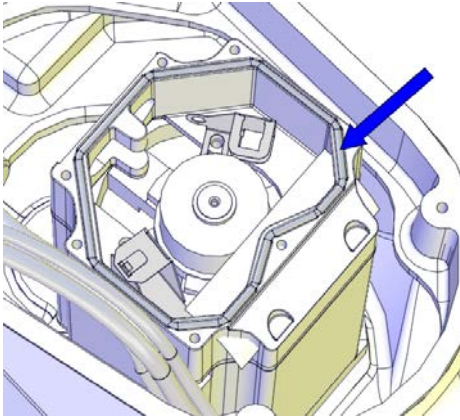
Continues on next page





	Action	Note
2	<p>Refit the cable gland cover by performing the following steps:</p> <ul style="list-style-type: none"> Slide the cable gland cover onto the inner screw. Refit and tighten the outer screw. Tighten the inner screw. Make sure that the gasket is not damaged. <p> Note</p> <p>Replace the gasket if damaged.</p>	 <p>xx1200001016</p>
3	<p>Connect the connectors. Connect in accordance with the markings on the connectors.</p>	 <p>xx1200001015</p>
4	<p>Make sure the o-ring on the motor is undamaged. Replace if damaged.</p>	<p>O-ring, axis 5: 3HAB3772-110 (circular profile) / 3HAC054692-001 (hexagon profile).</p>  <p>xx1200001021</p>
5	<p> CAUTION</p> <p>When fitting the motor cover, make sure that none of the cables inside will be damaged.</p>	

Continues on next page

4 Repair

4.7.5 Replacing the axis-5 motor

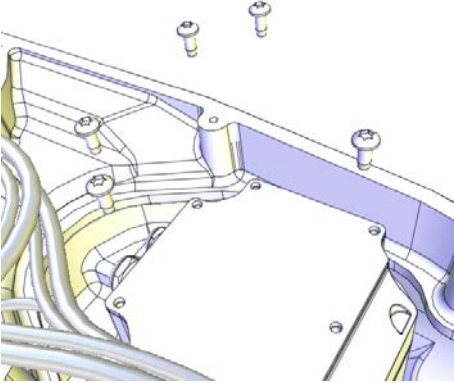
Continued

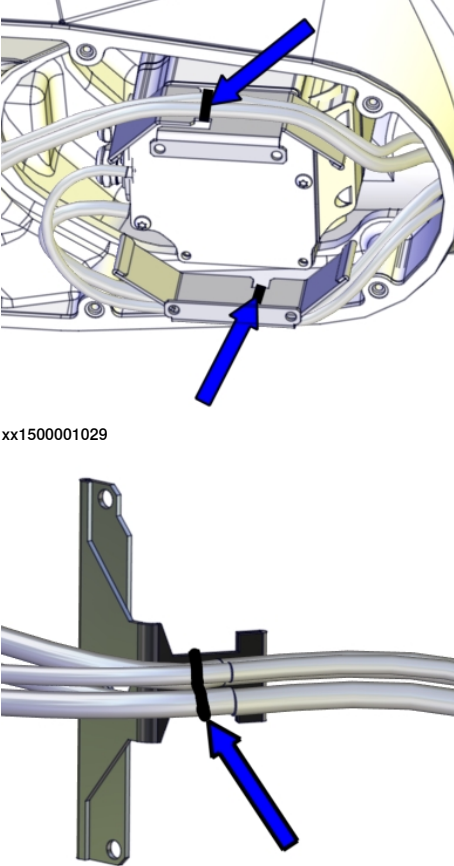
	Action	Note
6	<p>Refit the motor cover with its attachment screws.</p> <p> Note</p> <p>Do not refit the screws that will hold the heat protection plate at this point.</p> <p> Note</p> <p>Do not reuse the self-threading attachment screws, it will damage the threads. Replace with standard attachment screws.</p> <p> Note</p> <p>Make sure the o-ring is undamaged and properly fitted.</p>	<p>Screws: M5x12.</p>  <p>xx1200001013</p>
7	<p>Secure the cable harness with cable straps to the heat protection plate.</p> <p> Note</p> <p>If replacing a type A motor with a type B motor, the heat protection plate must be replaced with plates suited for the type B motor. See Type A vs type B motors on page 805.</p>	<p>There are two versions of the heat protection plates.</p> <p>Choose figure depending on which plate is installed on the robot.</p>  <p>xx1500001029</p> <p>xx1300000489</p>

Continues on next page

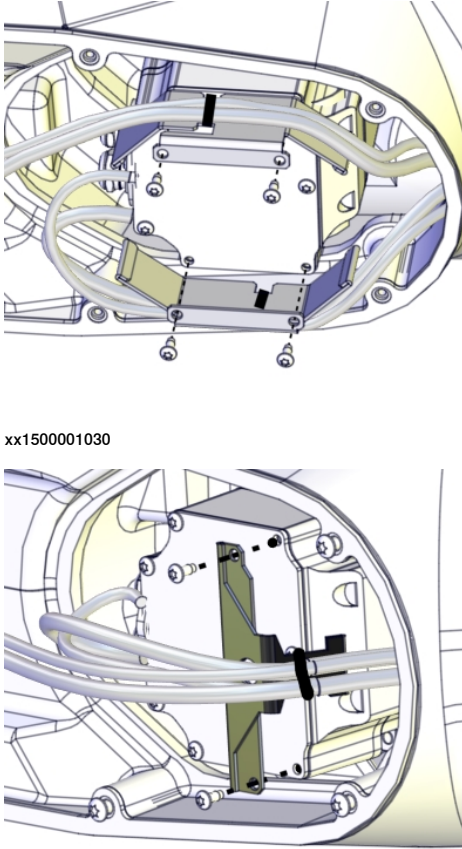
	Action	Note
8	Fit the heat protection plate with the screws.	<p>Choose figure depending on which plate is installed on the robot. Screws: M5x12.</p>  <p>xx1500001030</p> <p>xx1300000490</p>

Continues on next page

4 Repair



4.7.5 Replacing the axis-5 motor

Continued

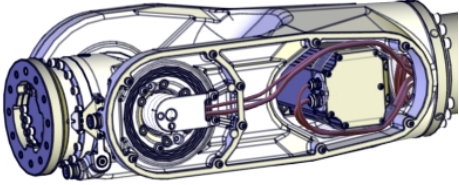
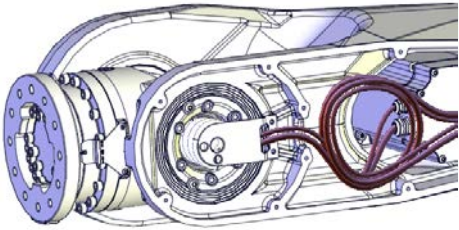
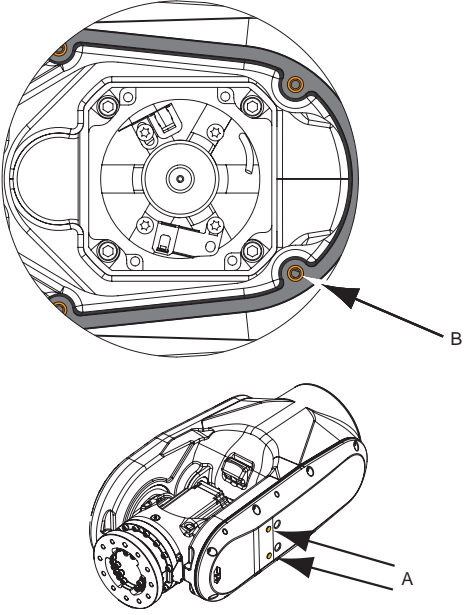
Concluding procedure

	Action	Note
1	<p>Make sure that the cable harness is placed in a way that it will not be damaged when the wrist cover is fitted.</p>	<p>There are two versions of the heat protection plates.</p> <p>Choose figure depending on which plate is installed on the robot.</p>  <p>xx1500001672</p>  <p>xx1300000596</p> <p>Cable layout in the wrist with Type A motors.</p>
2	<p>Foundry Plus: Inspect the gasket. Replace if damaged. Put washers in the holes of the gasket.</p>	 <p>xx1400000383</p> <p>A Protection plugs (2 on wrist cover and 2 on cover axis-5 gearbox) B Washers (10 pcs) in gasket holes</p>

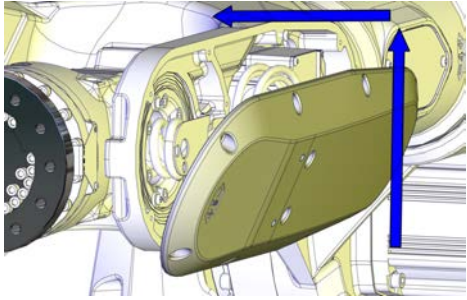
Continues on next page

	Action	Note
3	<p>Refit the wrist cover. In order not to damage the cable harness when the wrist cover is refitted, use this method:</p> <ol style="list-style-type: none"> 1 Hold the cover slightly tilted below the wrist. 2 Put the cable harness inside the cover. 3 Lift the cover, still tilted. 4 Move the upper part of the cover into position. 5 Secure the cover with its attachment screws. 	 <p>xx130000772</p> <p>Tightening torque: 10 Nm</p>
4	<p><i>Foundry Plus:</i> Refit protection plugs.</p>	
5	<p>If used, refit the DressPack cable package on the wrist.</p>	
6	<p>Re-calibrate the robot.</p>	<p>Pendulum Calibration is described in <i>Operating manual - Calibration Pendulum</i>, enclosed with the calibration tools.</p> <p>Axis Calibration is described in Calibrating with Axis Calibration method on page 781.</p> <p>General calibration information is included in section Calibration on page 767.</p>
7	<p> DANGER</p> <p>Make sure all safety requirements are met when performing the first test run.</p>	

4 Repair

4.7.6 Replacing the axis-6 motor

4.7.6 Replacing the axis-6 motor

Location of axis-6 motor

The axis-6 motor is located as shown in the figure.

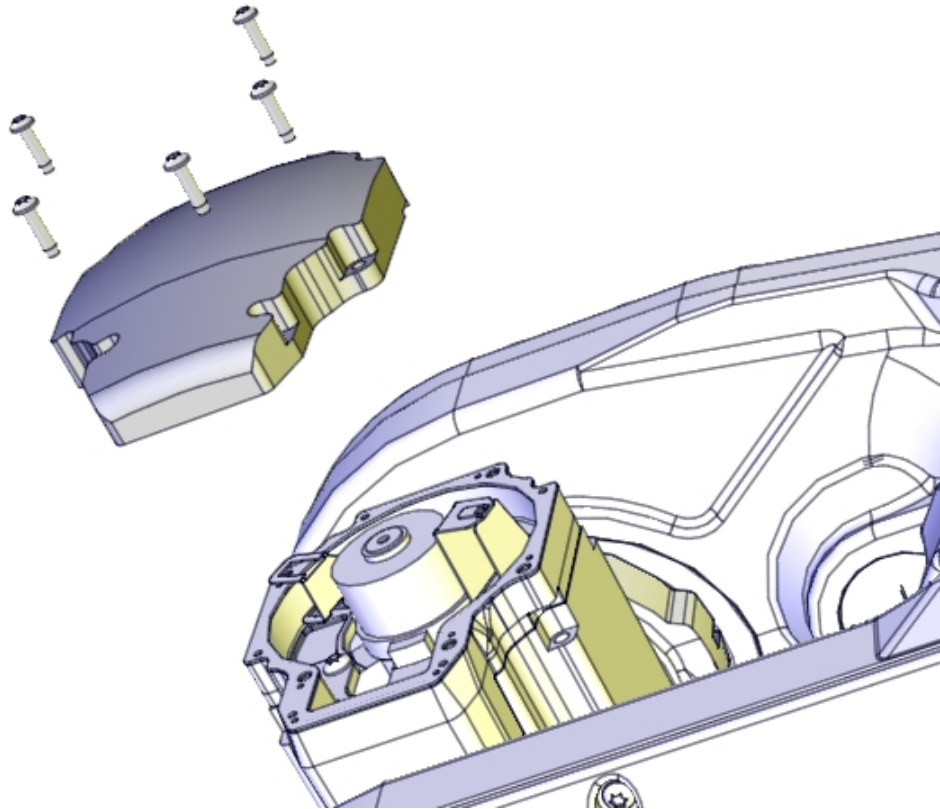

xx1200001080

Spare part

Spare part	Spare part number	Note
Axis-6 motor	See <i>Product manual, spare parts - IRB 6700/IRB 6700Inv.</i> <i>Product manual, spare parts - IRB 6790</i>	

Consumables

Equipment, etc.	Article number	Note
Grease	3HAC042536-001	Shell Gadus S2 Used to lubricate o-rings.
Gasket ⁱ	3HAC033489-001/ 3HAC044252-001	Used on motor cover.

Continues on next page

Equipment, etc.	Article number	Note
O-ring	3HAB3772-107 (IRB 6700 - 235/2.65, IRB 6700 - 205/2.80, IRB 6700 - 175/3.05, IRB 6700 - 150/3.20, IRB 6700 - 300/2.70, IRB 6700 - 245/3.00) 3HAB3772-102 (IRB 6700 - 200/2.60, IRB 6700 - 155/2.85)	D=102x3 Used on motor flange.

ⁱ Information about which of the two types of gasket to choose is found in *Product manual, spare parts - IRB 6700/IRB 6700Inv.*

Required tools and equipment

Equipment, etc.	Article number	Note
Removal tool kit M12 and M14	3HAC057339-002	Used to push out the motor, if necessary. Always use removal tools in pairs.
Rotation tool	3HAB7887-1	Used to rotate the motor pinion.
24 VDC power supply	-	Used to release the motor brakes.
Leak-down tester	-	
Calibration Pendulum toolkit	3HAC15716-1	Required if Calibration Pendulum is the valid calibration method for the robot.
Calibration tool box, Axis Calibration	3HAC055412-001	Delivered as a set of calibration tools. Required if Axis Calibration is the valid calibration method for the robot.
Standard toolkit	-	Content is defined in section Standard toolkit on page 814 .

Deciding calibration routine

Decide which calibration routine to be used, based on the information in the table. Depending on which routine is chosen, action might be required prior to beginning the repair work of the robot, see the table.

	Action	Note
1	Decide which calibration routine to use for calibrating the robot. <ul style="list-style-type: none"> Reference calibration. External cable packages (DressPack) and tools can stay fitted on the robot. Fine calibration. All external cable packages (DressPack) and tools must be removed from the robot. 	

Continues on next page

4 Repair

4.7.6 Replacing the axis-6 motor



Continued

Action	Note
<p>If the robot is to be calibrated with reference calibration: Find previous reference values for the axis or create new reference values. These values are to be used after the repair procedure is completed, for calibration of the robot.</p> <p>If no previous reference values exist, and no new reference values can be created, then reference calibration is not possible.</p>	<p>Follow the instructions given in the reference calibration routine on the FlexPendant to create reference values.</p> <p>Creating new values requires possibility to move the robot.</p> <p>Read more about reference calibration for Axis Calibration in Reference calibration routine on page 782.</p> <p>Read more about reference calibration for Pendulum Calibration in <i>Operating manual - Calibration Pendulum</i>.</p>
<p>If the robot is to be calibrated with fine calibration: Remove all external cable packages (DressPack) and tools from the robot.</p>	

Removing the axis-6 motor

Use these procedures to remove the motor.

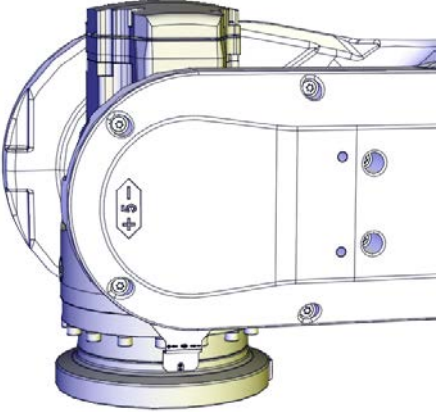
Preparations before removing the axis-6 motor

Action	Note	
1	Decide which calibration routine to use, and take actions accordingly prior to beginning the repair procedure.	
2	<p>Jog the robot to a position where axis 5 can be positioned with the motor pointing straight up at an acceptable working position.</p> <p>With axis 5 in this position it is possible to replace the motor without draining the oil from the axis-6 gearbox.</p>	 <p>xx1200001081</p>
3	<p> DANGER</p> <p>Turn off all:</p> <ul style="list-style-type: none"> • electric power supply • hydraulic pressure supply • air pressure supply <p>to the robot, before entering the safeguarded space.</p>	

Continues on next page

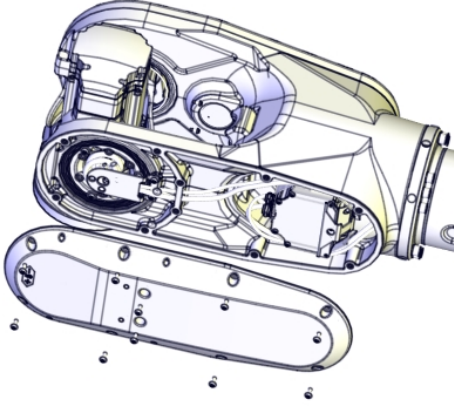
	Action	Note
4	Remove the wrist cover.	 <p>xx1300002247</p>

Disconnecting the axis-6 motor cables

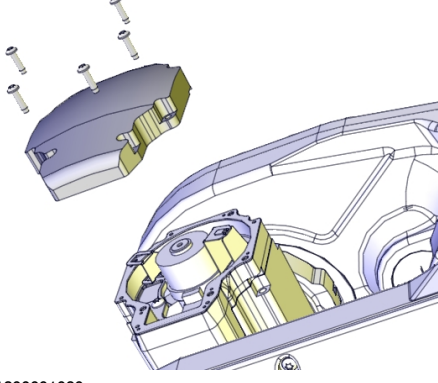
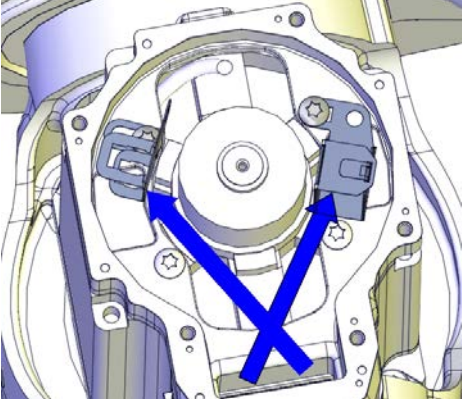

	Action	Note
1	 <p>DANGER</p> <p>Make sure that all supplies for electrical power, hydraulic pressure, and air pressure are turned off.</p>	
2	Unscrew the attachment screws and remove the motor cover.	 <p>xx1200001080</p>
3	Disconnect the motor cables.	 <p>xx1300000488</p>

Continues on next page

4 Repair

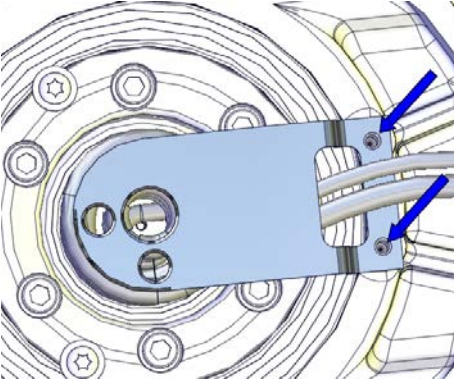

4.7.6 Replacing the axis-6 motor

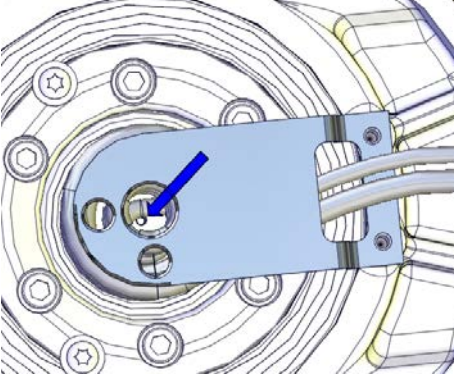
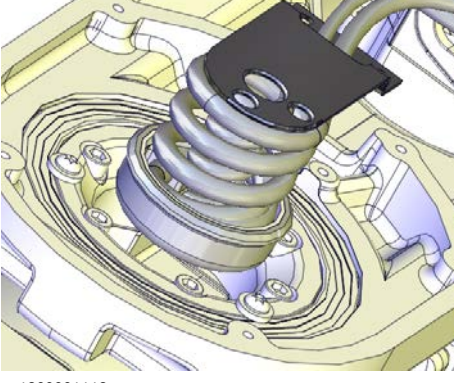
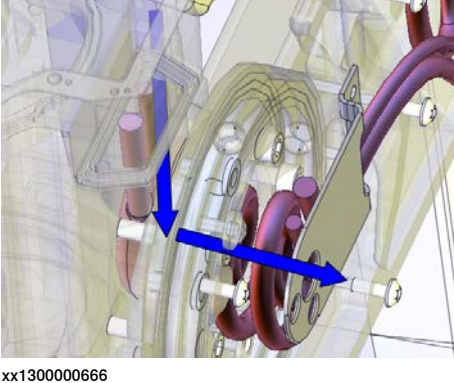
Continued

	Action	Note
4	Unscrew the attachment screws that hold the cable bracket.	 xx130000484
5	Unscrew the M4 screw that holds the carrier.  Note The screw is located at the bottom of the carrier.	 xx130000485
6	Pull out the carrier from its position.	 xx1300001113
7	Pull out the axis-6 motor cables by holding the cables with one hand at the motor and the other at the carrier.	 xx130000666

Continues on next page

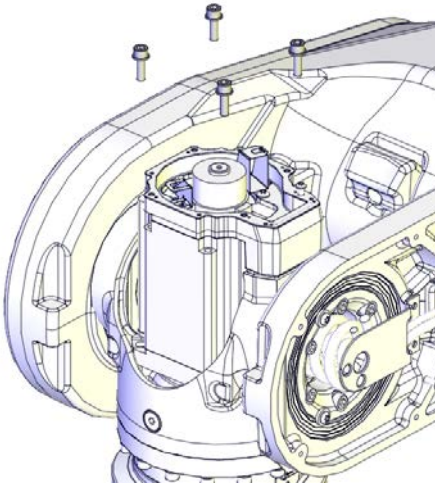
Removing the axis-6 motor

	Action	Note
1	To release the brakes, connect the 24 VDC power supply. Connect to R2.MP6-connector: <ul style="list-style-type: none"> • + = pin 2 • - = pin 5 	24 VDC power supply
2	Unscrew the motor attachment screws.	 xx1200001090
3	 CAUTION Whenever parting/mating motor and gearbox, the gears may be damaged if excessive force is used.	
4	If required, press the motor out of position by fitting the removal tool, motor to the attachment holes of the motor.	Removal tool kit M12 and M14: 3HAC057339-002 Always use removal tools in pairs.
5	 CAUTION The motor weighs 9 kg. All lifting accessories used must be sized accordingly.	

Continues on next page

4 Repair

4.7.6 Replacing the axis-6 motor

Continued

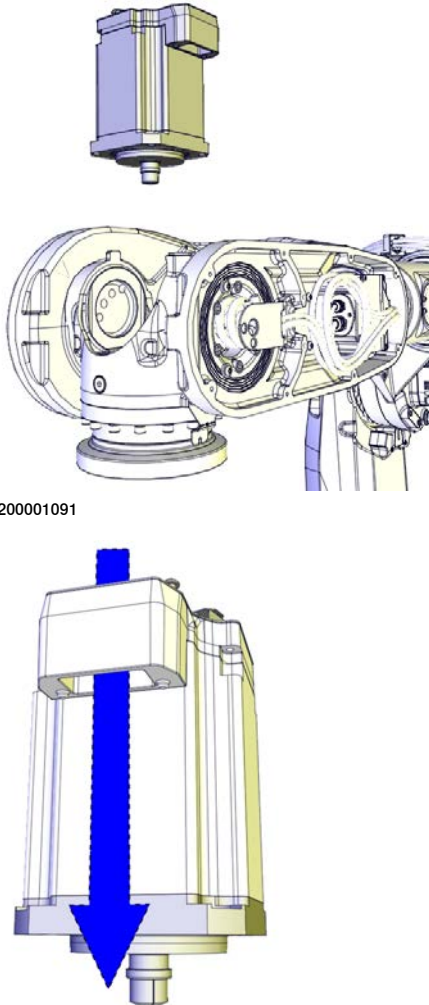
	Action	Note
6	<p>Remove the motor by lifting it straight up from the gear while at the same time picking out the motor cables from the motor. Make sure the motor pinion is not damaged!</p>	 <p>xx1200001091</p> <p>xx1200001096</p>
7	<p>Disconnect the 24 VDC power supply.</p>	



Refitting the axis-6 motor

Use this procedure to refit the motor.

Preparations prior to refitting motor

	Action	Note
1	 <p>DANGER</p> <p>Make sure that all supplies for electrical power, hydraulic pressure, and air pressure are turned off.</p>	

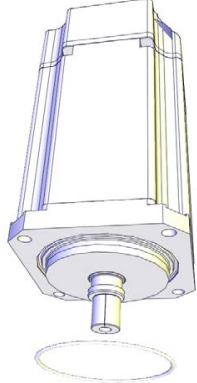
Continues on next page

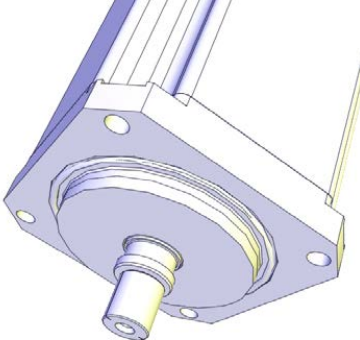
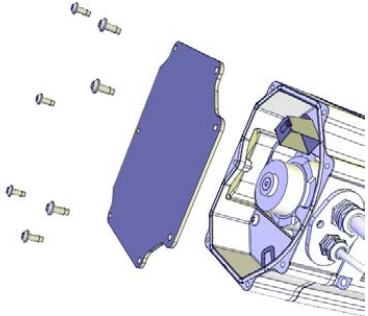
	Action	Note
2	<p>Remove any old paint residues or other contamination from the contact surfaces on both the motor and the mating parts. Wipe clean the contact surfaces and the o-ring groove.</p>	
3	<p>Fit a new o-ring.</p>	 <p>xx1200001019</p>
4	<p>Make sure the o-ring is seated in the groove.</p> <p> Tip Lubricate the o-ring with some grease for a better fitting in the groove.</p>	 <p>xx1200001020</p>
5	<p>If the motor is a new spare part, remove the cover.</p>	 <p>xx1200001135</p>





Continues on next page

4 Repair

4.7.6 Replacing the axis-6 motor

Continued

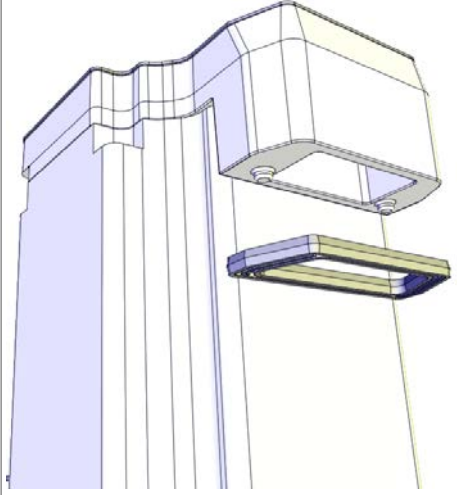
Securing the axis-6 motor

	Action	Note
1	 DANGER Make sure that all supplies for electrical power, hydraulic pressure, and air pressure are turned off.	
2	To release the brakes, connect the 24 VDC power supply. Connect to connector R2.MP6: <ul style="list-style-type: none">• + = pin 2• - = pin 5	
3	 CAUTION Whenever parting/mating motor and gear-box, the gears may be damaged if excessive force is used.	
4	Check the gasket. Replace if damaged.	 xx1200001094
5	 CAUTION The motor weighs 9 kg. All lifting accessories used must be sized accordingly.	

Continues on next page

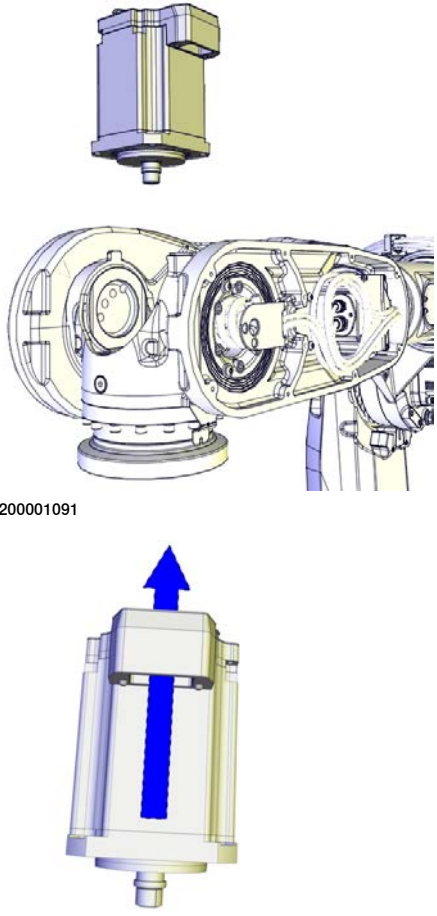
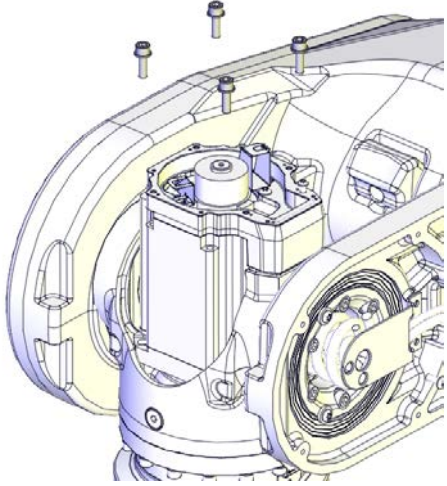

	Action	Note
6	<p>Fit the motor while, at the same, time pushing the motor cables in through the cable gland.</p> <p>Make sure the motor pinion is properly mated with the gear of the axis-6 gearbox.</p> <p>Make sure the motor pinion is not damaged!</p>	 <p>xx1200001091</p> <p>xx1200001097</p>
7	<p>Check that the gasket is fitted correctly.</p> <p>Secure the motor with its attachment screws.</p>	<p>Screws: M8x25 Steel 8.8-A2F (4 pcs)</p> <p>Tightening torque: 24 Nm</p>  <p>xx1200001090</p>

Continues on next page

4 Repair

4.7.6 Replacing the axis-6 motor

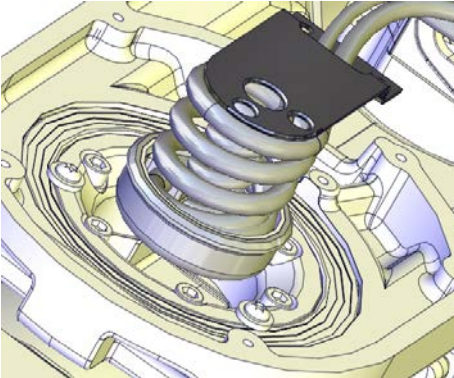
Continued

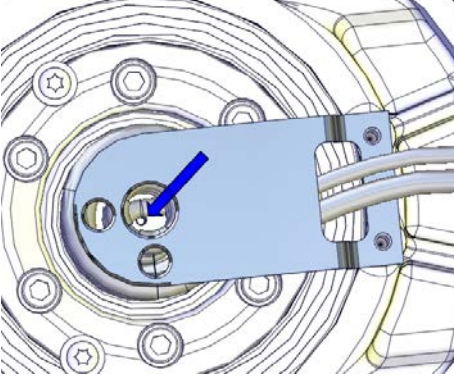
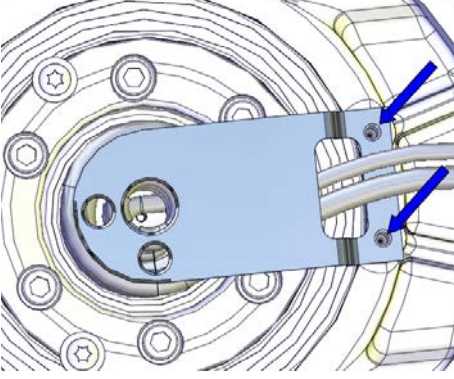
	Action	Note
8	Refit the axis-6 motor cables by carefully pushing them and the carrier into position.	 <p>xx1300001113</p>
9	Tighten the M4 screw that holds the carrier.  Note The screw is located at the bottom of the carrier.	 <p>xx1300000485</p>
10	Refit the cable bracket.	 <p>xx1300000484</p>
11	Perform a leak-down test.	See Performing a leak-down test on page 186 .
12	Disconnect the 24 V DC power supply.	

Continues on next page

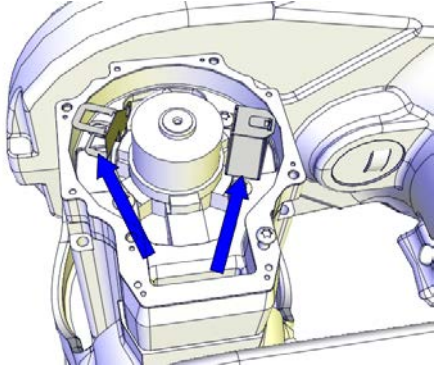
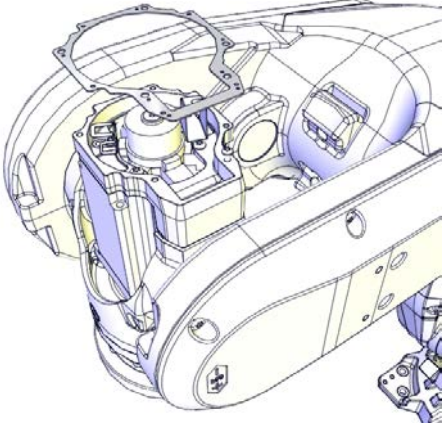
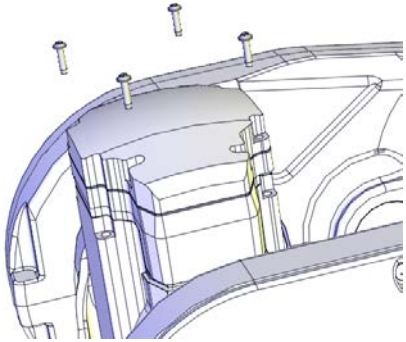
	Action	Note
13	Reconnect the connectors.	 <p>xx1200001084</p>
14	Check the gasket. Replace if damaged.	<p>Gasket: 3HAC033489-001/ 3HAC044252-001</p> <p>Information about which of the two types of gasket to choose is found in <i>Product manual, spare parts - IRB 6700/IRB 6700Inv.</i></p>  <p>xx1200001095</p>
15	Refit the motor cover.	 <p>xx1200001082</p>

Continues on next page

4 Repair



4.7.6 Replacing the axis-6 motor

Continued

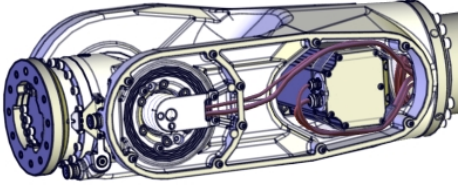
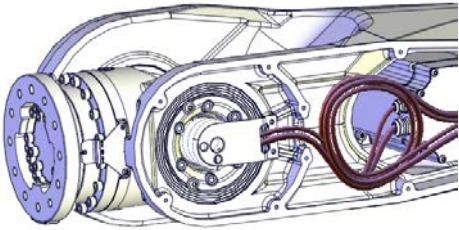
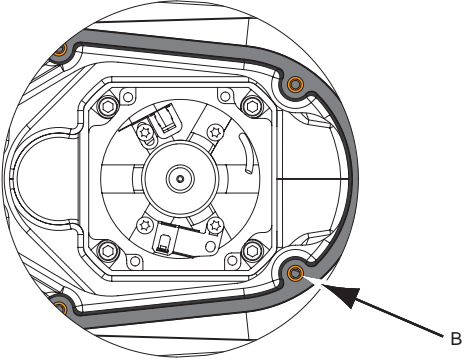
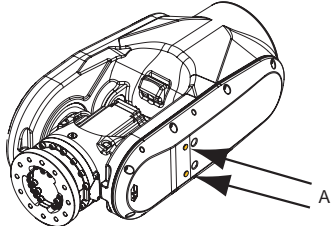
Concluding procedure

	Action	Note
1	<p>Make sure that the cable harness is placed in a way that it will not be damaged when the wrist cover is fitted.</p>	<p>There are two versions of the heat protection plates.</p> <p>Choose figure depending on which plate is installed on the robot.</p>  <p>xx1500001672</p>  <p>xx1300000596</p> <p>Cable layout in the wrist with Type A motors.</p>
2	<p>Foundry Plus: Inspect the gasket. Replace if damaged. Put washers in the holes of the gasket.</p>	  <p>xx1400000383</p> <p>A Protection plugs (2 on wrist cover and 2 on cover axis-5 gearbox) B Washers (10 pcs) in gasket holes</p>

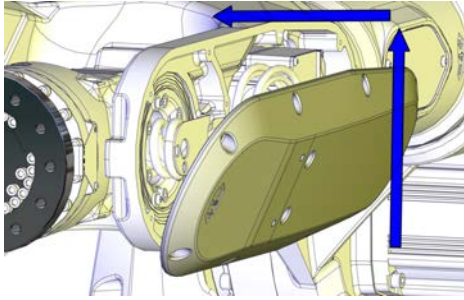
Continues on next page

	Action	Note
3	<p>Refit the wrist cover. In order not to damage the cable harness when the wrist cover is refitted, use this method:</p> <ol style="list-style-type: none"> 1 Hold the cover slightly tilted below the wrist. 2 Put the cable harness inside the cover. 3 Lift the cover, still tilted. 4 Move the upper part of the cover into position. 5 Secure the cover with its attachment screws. 	 <p>xx1300000772</p> <p>Tightening torque: 10 Nm</p>
4	<p><i>Foundry Plus:</i> Refit protection plugs.</p>	
5	<p>If used, refit the DressPack cable package on the wrist.</p>	
6	<p>Re-calibrate the robot.</p>	<p>Pendulum Calibration is described in <i>Operating manual - Calibration Pendulum</i>, enclosed with the calibration tools.</p> <p>Axis Calibration is described in Calibrating with Axis Calibration method on page 781.</p> <p>General calibration information is included in section Calibration on page 767.</p>
7	<p> DANGER</p> <p>Make sure all safety requirements are met when performing the first test run.</p>	

4 Repair

4.8.1 Replacing the axis-1 gearbox (IRB 6700 - 235/2.65, IRB 6700 - 205/2.80, IRB 6700 - 175/3.05, IRB 6700 - 150/3.20, IRB 6700 - 200/2.60, IRB 6700 - 155/2.85)

4.8 Gearboxes

4.8.1 Replacing the axis-1 gearbox (IRB 6700 - 235/2.65, IRB 6700 - 205/2.80, IRB 6700 - 175/3.05, IRB 6700 - 150/3.20, IRB 6700 - 200/2.60, IRB 6700 - 155/2.85)

Validity of this section



Note

This section describes how to replace the gearbox on variants IRB 6700 - 235/2.65, IRB 6700 - 205/2.80, IRB 6700 - 175/3.05, IRB 6700 - 150/3.20, IRB 6700 - 200/2.60, IRB 6700 - 155/2.85.

How to replace the gearbox on variants IRB 6700 - 300/2.70, IRB 6700 - 245/3.00 see [Replacing the axis-1 gearbox \(IRB 6700 - 300/2.70, IRB 6700 - 245/3.00\) on page 603](#).

Location of the axis-1 gearbox

The axis-1 gearbox is located as shown in the figure.

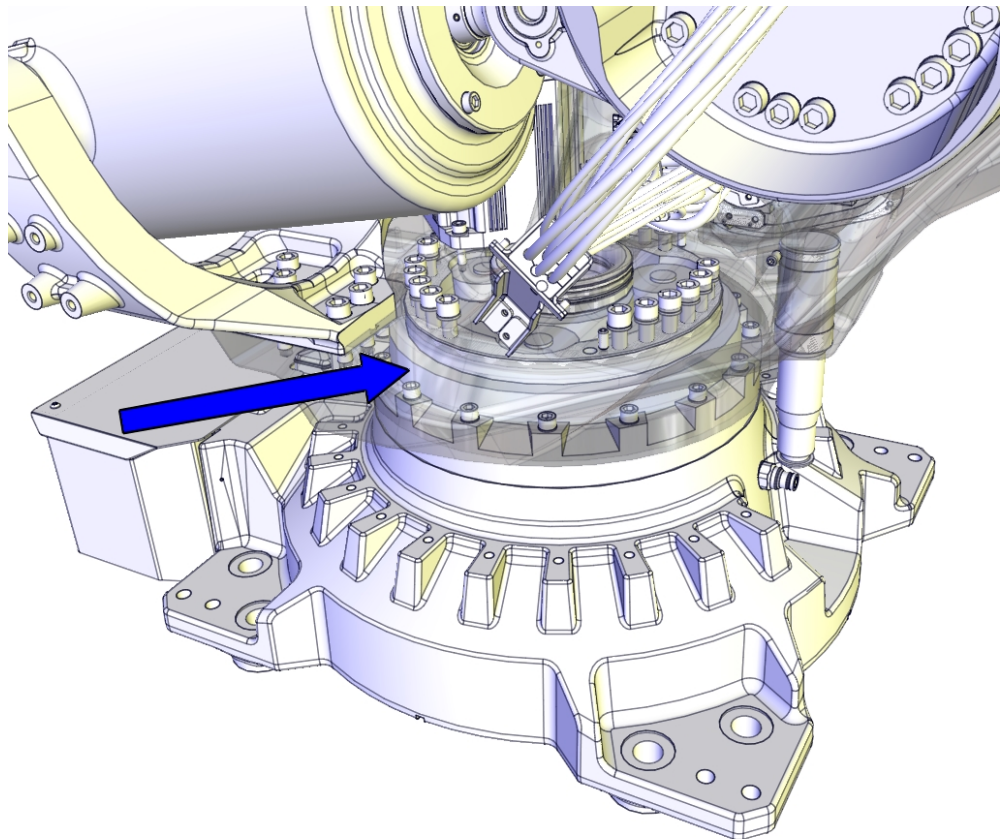

xx1200001183

Continues on next page

4.8.1 Replacing the axis-1 gearbox (IRB 6700 - 235/2.65, IRB 6700 - 205/2.80, IRB 6700 - 175/3.05, IRB 6700 - 150/3.20, IRB 6700 - 200/2.60, IRB 6700 - 155/2.85)

Continued

Summary of the replacement procedure

This list is a brief summary of the replacement procedure, containing the major actions to be performed.

- 1 Drain the axis-1 gearbox.
- 2 Remove the cabling from the base.
- 3 Remove the axis-1 motor.
- 4 Remove the complete arm system (including frame and balancing device) as a package.
- 5 Replace the axis-1 gearbox.
- 6 Refit in reverse order.

Spare parts

Spare parts	Article number	Note
Axis-1 gearbox	See <i>Product manual, spare parts - IRB 6700/IRB 6700Inv.</i>	

Consumables

Equipment, etc.	Article number	Note
Locking liquid	3HAB7116-1	Loctite 243
Flange sealant	-	Loctite 574
Grease	3HAC042536-001	Shell Gadus S2
O-ring, nitrile rubber	3HAB3772-93	380.59x3.53
O-ring, nitrile rubber	3HAB3772-164 or 3HAC061327-002 (depends on gearbox variant, see <i>Product manual, spare parts - IRB 6700</i>)	
O-ring ⁱ	3HAB3772-111 (circular profile) / 3HAC054692-002 (hexagon profile)	169.5x3 / 169.5x4.8x2.65
O-ring, nitrile rubber	3HAB3772-107	102x3
Cable straps	-	
Sealing ring	-	

ⁱ The cross-section profile is either circular or hexagon. If only ordering the o-ring, order the same profile that is currently installed in the connection box.

Required tools and equipment

Equipment, etc.	Article number	Note
Oil collecting vessel	-	The capacity of the vessel must be sufficient to take the complete amount of oil.
Oil dispenser	-	One example of oil dispenser can be found in section <i>Type of lubrication in gearboxes on page 145</i> .
Bits extender	3HAC12342-1	300 mm, bits 1/2"

Continues on next page

4 Repair

4.8.1 Replacing the axis-1 gearbox (IRB 6700 - 235/2.65, IRB 6700 - 205/2.80, IRB 6700 - 175/3.05, IRB 6700 - 150/3.20, IRB 6700 - 200/2.60, IRB 6700 - 155/2.85)

Continued

Equipment, etc.	Article number	Note
Lifting eye	3HAC16131-1	M12
Lifting eye	3HAC16131-1	M12
Fender washer	-	Outer diameter: minimum 26 mm, maximum 30 mm, hole diameter: 13 mm, thickness: 3 mm.
Lifting shackle	-	SA-10-8-NA1
Roundsling, 1.5 m	-	Length: 1.5 m. Lifting capacity: 2,000 kg.
Roundsling, 1 m	-	Length: 1 m, lifting capacity: 1,000 kg.
Lifting accessory (chain)	3HAC15556-1	Lifting instruction 3HAC15880-2 enclosed.
Lifting eye	3HAC14457-4	M16
Removal tool kit M12 and M14	3HAC057339-002	Required dimension of removal tool depends on motor type A or B, see Identifying the motor by article number on page 805 Used to push out the motor, if necessary. Always use removal tools in pairs.
Lifting accessory, motor	3HAC14459-1	
Rotation tool	3HAB7887-1	Used to rotate the motor pinion.
Aligning tool	3HAC046645-003	Used for aligning the gearbox against the frame, so that the play in the motor does not need to be adjusted.
24 VDC power supply	-	Used to release the motor brakes.
Guide for reduction gear	3HAC043870-009	Used to guide axis-1 gear and frame during refitting. Valid for IRB 6700 - 235/2.65, IRB 6700 - 205/2.80, IRB 6700 - 175/3.05, IRB 6700 - 150/3.20, IRB 6700 - 200/2.60, IRB 6700 - 155/2.85.
Guide pin, M10x150	3HAC15521-2	Always use guide pins in pairs.
Guide pin, M12x150	3HAC13056-2	Always use guide pins in pairs.
Guide pin, M16x150	3HAC13120-2	Always use guide pins in pairs.
Guide pin, M16x200	3HAC13120-3	Always use guide pins in pairs.
Leak-down tester	-	
Calibration Pendulum toolkit	3HAC15716-1	Required if Calibration Pendulum is the valid calibration method for the robot.
Calibration tool box, Axis Calibration	3HAC055412-001	Delivered as a set of calibration tools. Required if Axis Calibration is the valid calibration method for the robot.
Standard toolkit	-	Content is defined in section Standard toolkit on page 814 .

Continues on next page

4.8.1 Replacing the axis-1 gearbox (IRB 6700 - 235/2.65, IRB 6700 - 205/2.80, IRB 6700 - 175/3.05, IRB 6700 - 150/3.20, IRB 6700 - 200/2.60, IRB 6700 - 155/2.85)

Continued

Required documents

Document name	Document number	Note
Technical reference manual - Lubrication in gearboxes	3HAC042927-001	

Deciding calibration routine

Decide which calibration routine to be used, based on the information in the table. Depending on which routine is chosen, action might be required prior to beginning the repair work of the robot, see the table.

	Action	Note
1	Decide which calibration routine to use for calibrating the robot. <ul style="list-style-type: none"> Reference calibration. External cable packages (DressPack) and tools can stay fitted on the robot. Fine calibration. All external cable packages (DressPack) and tools must be removed from the robot. 	
	If the robot is to be calibrated with reference calibration: Find previous reference values for the axis or create new reference values. These values are to be used after the repair procedure is completed, for calibration of the robot. If no previous reference values exist, and no new reference values can be created, then reference calibration is not possible.	Follow the instructions given in the reference calibration routine on the FlexPendant to create reference values. Creating new values requires possibility to move the robot. Read more about reference calibration for Axis Calibration in Reference calibration routine on page 782 . Read more about reference calibration for Pendulum Calibration in <i>Operating manual - Calibration Pendulum</i> .
	If the robot is to be calibrated with fine calibration: Remove all external cable packages (DressPack) and tools from the robot.	

Removing the axis-1 gearbox

These procedures describe how to remove the gearbox.

Preparations before removing the axis-1 gearbox

Use this procedure to do the necessary preparations, before removing the axis-1 gearbox.



	Action	Note
1	Decide which calibration routine to use, and take actions accordingly prior to beginning the repair procedure.	
2	Remove tools and other equipment fitted on the turning disc. DressPack can stay fitted for the time being.	This is done to achieve the best stability of the complete arm system when it is resting by itself, after it has been removed.
3	Begin draining the axis-1 gearbox.	See Draining the axis-1 gearbox on page 148 .

Continues on next page

4 Repair

4.8.1 Replacing the axis-1 gearbox (IRB 6700 - 235/2.65, IRB 6700 - 205/2.80, IRB 6700 - 175/3.05, IRB 6700 - 150/3.20, IRB 6700 - 200/2.60, IRB 6700 - 155/2.85)

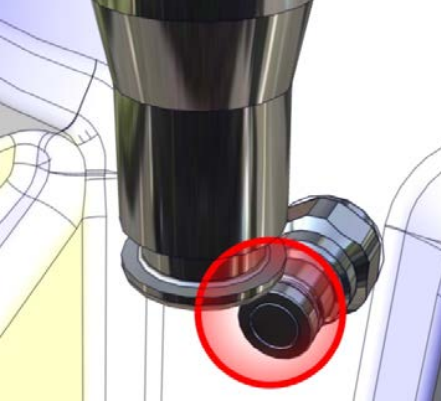

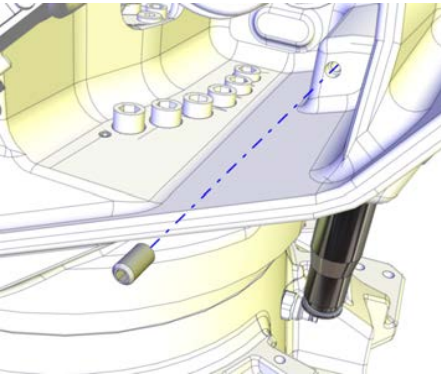
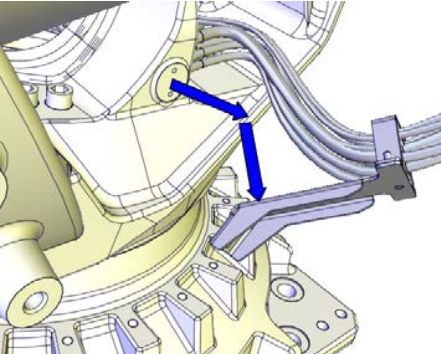
Continued

	Action	Note
4	Jog the robot into position: <ul style="list-style-type: none"> axis 1 = -5° 	The specified position of axis-1 is required for removal of the mechanical stop pin.  xx1300000478
5	 DANGER Turn off all: <ul style="list-style-type: none"> electric power supply hydraulic pressure supply air pressure supply to the robot, before entering the safeguarded space.	
6	Hold the mechanical stop pin in a firm grip, and remove it by unscrewing the set screw.  CAUTION The mechanical stop pin weighs 5 kg and may fall down when the set screw is removed.	 xx1300000476
7	Unscrew the attachment screws that secure the cable bracket.	 xx1200001184

Continues on next page

4.8.1 Replacing the axis-1 gearbox (IRB 6700 - 235/2.65, IRB 6700 - 205/2.80, IRB 6700 - 175/3.05, IRB 6700 - 150/3.20, IRB 6700 - 200/2.60, IRB 6700 - 155/2.85)

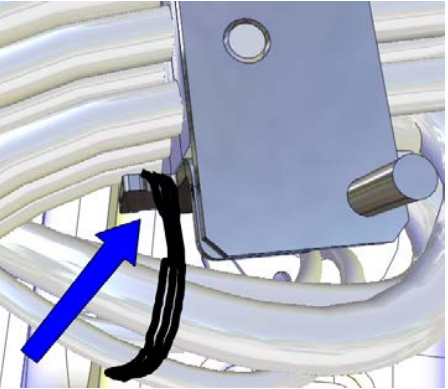
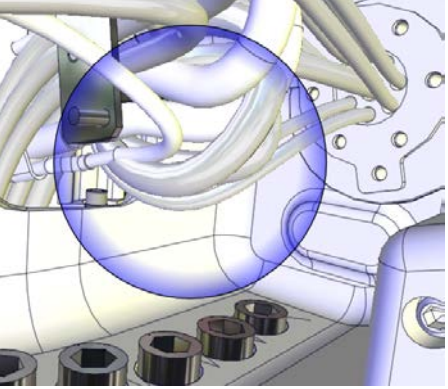
Continued

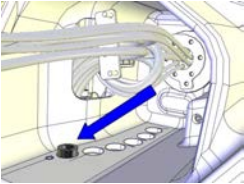
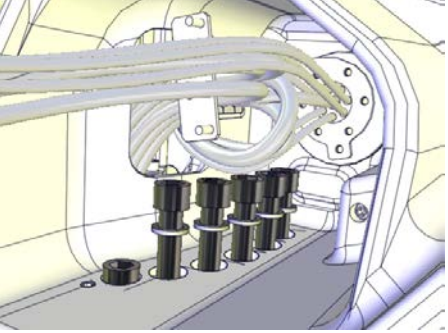
	Action	Note
8	Cut the cable tie inside the frame recess.	 <p>xx1200001237</p>
9	<p>Lift up the part of the cable harness shown in the figure, and let it rest against the bracket.</p> <p>This is done to be able to reach all attachment screws inside the recess.</p>	 <p>xx1200001240</p>
10	<p>Unscrew five of the six attachment screws inside the frame recess, that secure the frame to the gearbox.</p> <p> Note</p> <p>Leave the outermost screw fitted as a safety precaution.</p>  <p>xx1200001185</p>	 <p>xx1200001189</p>

Continues on next page

4 Repair

4.8.1 Replacing the axis-1 gearbox (IRB 6700 - 235/2.65, IRB 6700 - 205/2.80, IRB 6700 - 175/3.05, IRB 6700 - 150/3.20, IRB 6700 - 200/2.60, IRB 6700 - 155/2.85)

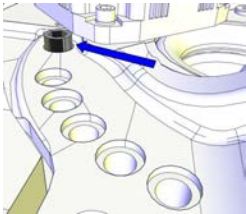
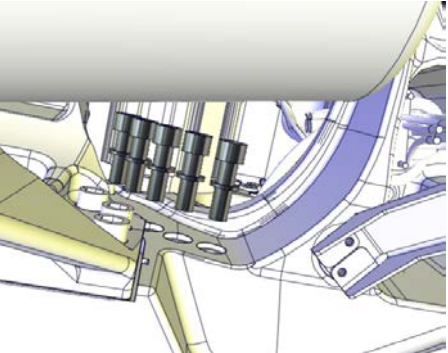

Continued

	Action	Note
11	<p>Unscrew five of the six attachment screws under the balancing device.</p> <p> Note</p> <p>Leave the screw closest to the axis-1 motor fitted.</p>  <p>xx1200001239</p>	 <p>xx1200001238</p>

Robot position

Use this procedure to jog the robot into position.

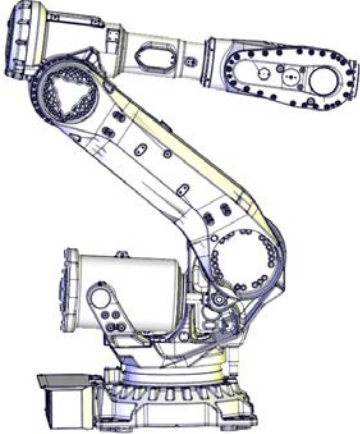
Valid for variants IRB 6700 - 235/2.65, IRB 6700 - 205/2.80, IRB 6700 - 175/3.05, IRB 6700 - 150/3.20, IRB 6700 - 200/2.60, IRB 6700 - 155/2.85.

	Action	Note
1	<p>Jog the robot into position:</p> <ul style="list-style-type: none"> • Axis 1: no significance as long as the robot is secured to the foundation. • Axis 2: -40° • Axis 3: +65° (approximately) • Axis 4: calibration position (0°) • Axis 5: +90° • Axis 6: calibration position (0°) 	 <p>xx1200001132</p>
2	<p> DANGER</p> <p>Turn off all:</p> <ul style="list-style-type: none"> • electric power supply • hydraulic pressure supply • air pressure supply <p>to the robot, before entering the robot working area.</p>	

Attaching the lifting accessories



Use this procedure to attach the lifting accessories.

Continues on next page

4.8.1 Replacing the axis-1 gearbox (IRB 6700 - 235/2.65, IRB 6700 - 205/2.80, IRB 6700 - 175/3.05, IRB 6700 - 150/3.20, IRB 6700 - 200/2.60, IRB 6700 - 155/2.85)

Continued

Valid for variants IRB 6700 - 235/2.65, IRB 6700 - 205/2.80, IRB 6700 - 175/3.05, IRB 6700 - 150/3.20, IRB 6700 - 200/2.60, IRB 6700 - 155/2.85.

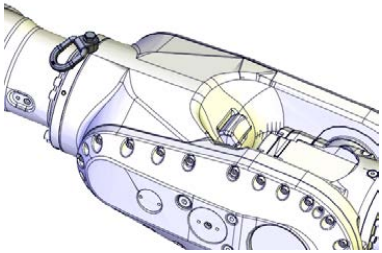
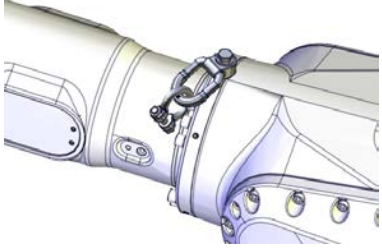
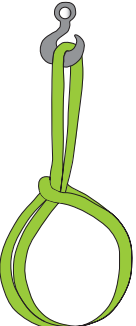
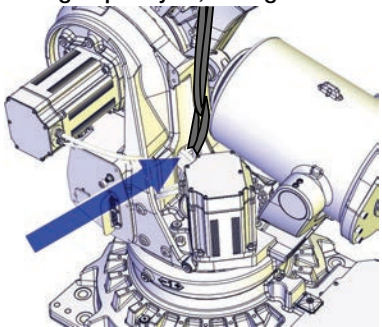

	Action	Note
1	 DANGER Make sure that all supplies for electrical power, hydraulic pressure, and air pressure are turned off.	
2	 CAUTION The complete arm system weigh (according to variants) 1100 kg. All lifting accessories used must be sized accordingly.	
3	Fit a lifting eye to the wrist.	Lifting eye: 3HAC16131-1  xx1200001133
4	Fit a lifting shackle in the wrist lifting eye.	Lifting shackle: SA-10-8-NA1  xx1200001234
5	Run a roundsling through the hole in the frame. Attach the roundsling choked. See figure!  xx1400000730	Roundsling, 1.5 m: Length: 1.5 m. Lifting capacity: 2,000 kg.  xx1200001209

Continues on next page

4 Repair

4.8.1 Replacing the axis-1 gearbox (IRB 6700 - 235/2.65, IRB 6700 - 205/2.80, IRB 6700 - 175/3.05, IRB 6700 - 150/3.20, IRB 6700 - 200/2.60, IRB 6700 - 155/2.85)

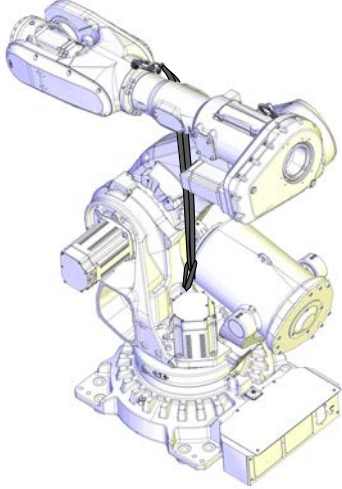
Continued

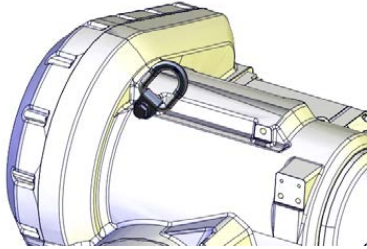
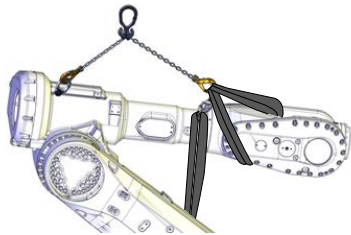
	Action	Note
6 7	<p>Attach the roundsling to the shackle on the wrist.</p> <p>Jog axis-3 slowly until the roundsling is stretched (approximately +58°), to carry the weight of the lower arm and frame.</p> <p> WARNING</p> <p>Without the roundsling the weight of the lower arm and frame is applied to the axis-3 gear during lifting, which risks to damage the gear.</p>	 <p>xx1200001235</p>
8	<p>Fit a lifting eye in the arm house, with a fender washer underneath.</p>  <p>xx1400002196</p> <p>Fender washer</p>	<p>Lifting eye: 3HAC16131-1</p> <p>Fender washer. Outer diameter: minimum 26 mm, maximum 30 mm, hole diameter: 13 mm, thickness: 3 mm.</p>  <p>xx1200001134</p>
9	<p>Attach the Lifting accessory (chain) to an overhead crane (or similar) and then to the lifting eye in the arm house and to a roundsling run through the wrist.</p>	<p>Lifting accessory (chain): 3HAC15556-1</p> <p>Roundsling, 1 m: Length: 1 m, lifting capacity: 1,000 kg.</p>  <p>xx1200001236</p>

Continues on next page

4.8.1 Replacing the axis-1 gearbox (IRB 6700 - 235/2.65, IRB 6700 - 205/2.80, IRB 6700 - 175/3.05, IRB 6700 - 150/3.20, IRB 6700 - 200/2.60, IRB 6700 - 155/2.85)

Continued

Removing the axis-1 motor protection plates

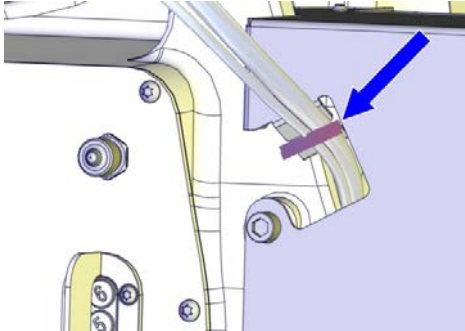
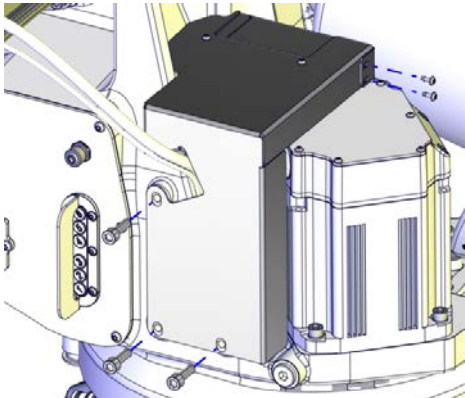
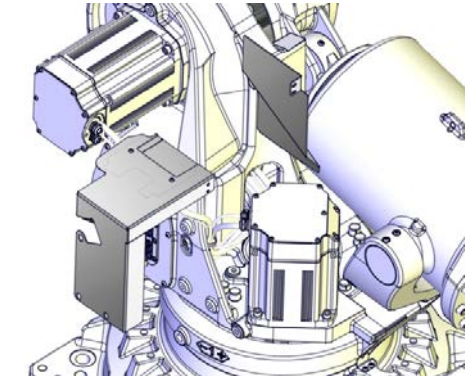
	Action	Note
1	<p><i>Foundry Plus.</i> Cut the cable tie that hold the axis-1 and axis-2 motor cables on the protection plates.</p>	 <p>xx140000722</p>
2	<p><i>Foundry Plus.</i> Disassemble the protection plates by removing five of the attachment screws (three M10x30 and two of the M5x12 screws).</p>	 <p>xx140000723</p>
3	<p><i>Foundry Plus.</i> Remove the two protection plates.</p>	 <p>xx140000724</p>

Disconnecting the axis-1 motor cables

	Action	Note
1	<p> DANGER Make sure that all supplies for electrical power, hydraulic pressure, and air pressure are turned off.</p>	

Continues on next page

4 Repair

4.8.1 Replacing the axis-1 gearbox (IRB 6700 - 235/2.65, IRB 6700 - 205/2.80, IRB 6700 - 175/3.05, IRB 6700 - 150/3.20, IRB 6700 - 200/2.60, IRB 6700 - 155/2.85)

Continued

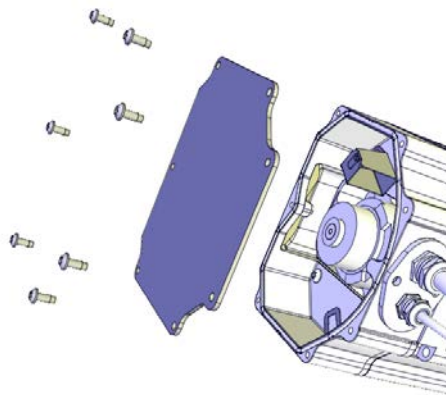
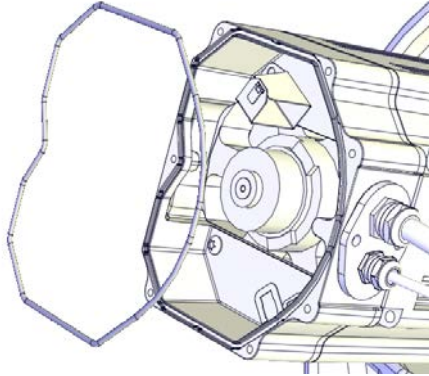
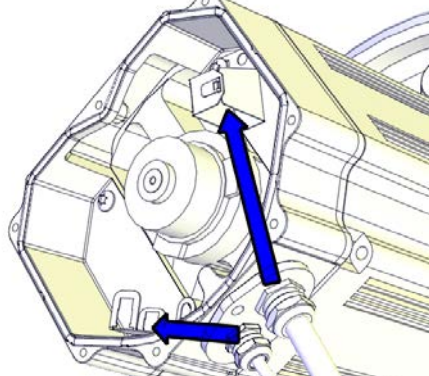
	Action	Note
2	Unscrew the attachment screws and washers and remove the motor cover.	 xx1200001135
3	Make sure the o-ring is present.	 xx1200001070
4	Disconnect the motor cables.	 xx1200001066



Continues on next page

4.8.1 Replacing the axis-1 gearbox (IRB 6700 - 235/2.65, IRB 6700 - 205/2.80, IRB 6700 - 175/3.05, IRB 6700 - 150/3.20, IRB 6700 - 200/2.60, IRB 6700 - 155/2.85)

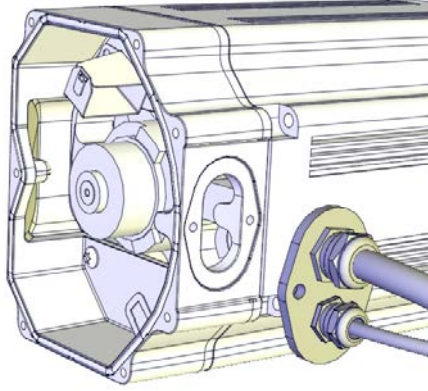
Continued

	Action	Note
5	<p>Remove the cable gland cover. Make sure the gasket is not damaged.</p> <p> Tip</p> <p>Make a note in which direction the cable gland hole is facing, if the motor will be removed too. The motor shall be refitted in the same position.</p>	 <p>xx1200001067</p>
6	Use caution and pull out the motor cables.	

Removing the axis-1 motor



	Action	Note
1	<p> DANGER</p> <p>Make sure that all supplies for electrical power, hydraulic pressure, and air pressure are turned off.</p>	
2	Attach the lifting accessories.	<p>Lifting accessory (chain): 3HAC15556-1 Lifting accessory, motor: 3HAC14459-1.</p>
3	<p>To release the brakes, connect the 24 VDC power supply. Connect to R2.MP1-connector:</p> <ul style="list-style-type: none"> • + = pin 2 • - = pin 5 	24 VDC power supply
4	<p> CAUTION</p> <p>The weight of the motor is 25 kg All lifting accessories used must be sized accordingly.</p>	

Continues on next page

4 Repair

4.8.1 Replacing the axis-1 gearbox (IRB 6700 - 235/2.65, IRB 6700 - 205/2.80, IRB 6700 - 175/3.05, IRB 6700 - 150/3.20, IRB 6700 - 200/2.60, IRB 6700 - 155/2.85)

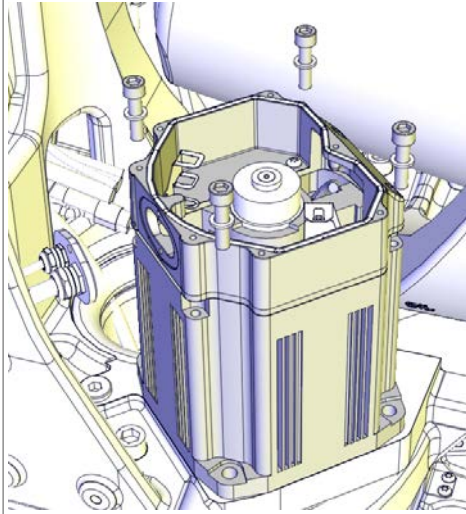
Continued

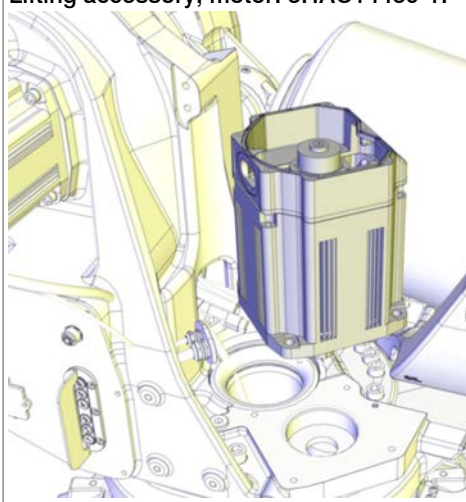
	Action	Note
5	Unscrew the attachment screws and washers. Use a bits extender to reach the screws.	Bits extender: 3HAC12342-1  xx1200001071
6	Fit guide pins in opposite holes.	Guide pin, M10x150: 3HAC15521-2 Always use guide pins in pairs.
7	 CAUTION Whenever parting/mating motor and gearbox, the gears may be damaged if excessive force is used.	
8	If needed, use removal tools to help remove the motor.	Removal tool kit M12 and M14: 3HAC057339-002 Required dimension of removal tool depends on motor type A or B, see Identifying the motor by article number on page 805 Used to push out the motor, if necessary. Always use removal tools in pairs.
9	Use caution and lift the motor straight up to get the pinion parted from the gear.	Lifting accessory (chain): 3HAC15556-1 Lifting accessory, motor: 3HAC14459-1.  xx1200001072

Continues on next page

4.8.1 Replacing the axis-1 gearbox (IRB 6700 - 235/2.65, IRB 6700 - 205/2.80, IRB 6700 - 175/3.05, IRB 6700 - 150/3.20, IRB 6700 - 200/2.60, IRB 6700 - 155/2.85)

Continued

Action	Note
10 Disconnect the 24 VDC power supply.	

Preparations before removing the cable harness in the base

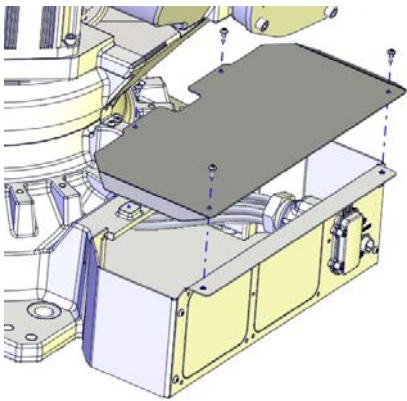
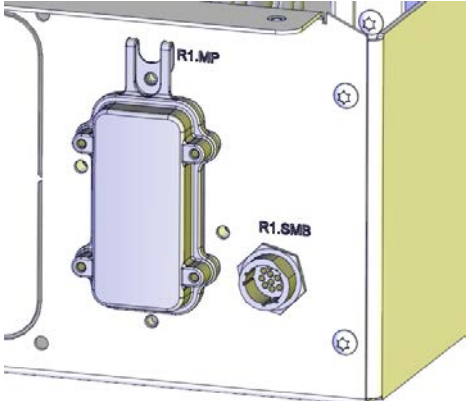
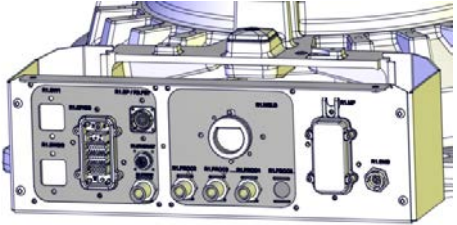

Action	Note
<p>1</p>  <p>DANGER</p> <p>Make sure that all supplies for electrical power, hydraulic pressure, and air pressure are turned off.</p>	
<p>2 Remove the base cover.</p>	 <p>xx1300000561</p>
<p>3 Disconnect connectors:</p> <ul style="list-style-type: none"> • R1.MP • R1.SMB 	 <p>xx1300000591</p>
<p>4 If used, disconnect the DressPack hoses in the base.</p>	 <p>xx1400000366</p>

Continues on next page

4 Repair

4.8.1 Replacing the axis-1 gearbox (IRB 6700 - 235/2.65, IRB 6700 - 205/2.80, IRB 6700 - 175/3.05, IRB 6700 - 150/3.20, IRB 6700 - 200/2.60, IRB 6700 - 155/2.85)

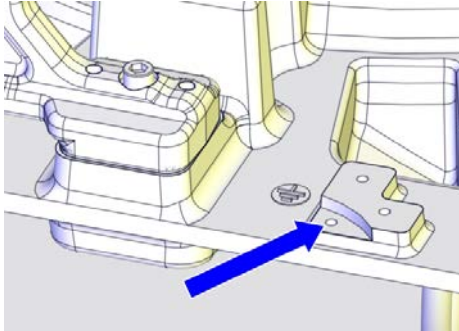
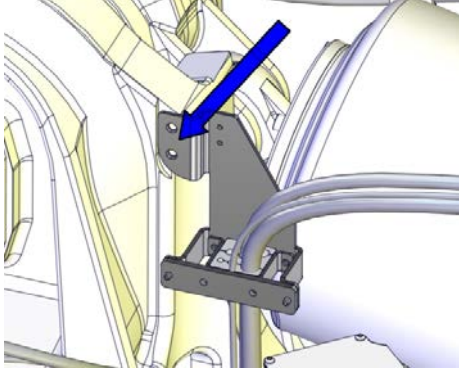
Continued

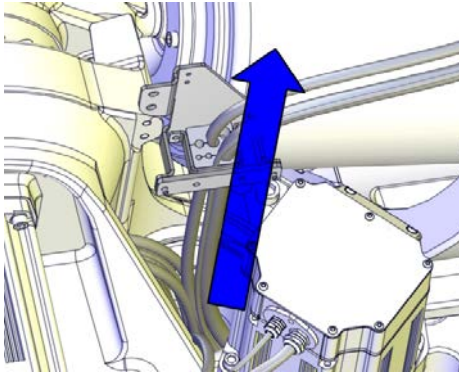
	Action	Note
5	Disconnect the earth cable.	<p>Screw dimension : M6x16 Washer dimension : 6.4x17x3</p>  <p>xx1400000354</p>
6	<p>If used, remove the attachment screws that secure the bracket. This is done to facilitate removal of the DressPack hoses.</p>	 <p>xx1400000078</p>
7	<p>If used, use caution and pull out the DressPack hoses through the protection tube in the base.</p> <p> Note</p> <p>There is no need to pull out the DressPack cables at this point!</p>	 <p>xx1400000088</p>

Removing the cable harness in the base

	Action	Note
1	<p>If equipped with DressPack, pull out the DressPack cables through the protection tube and place them carefully over the balancing device.</p>	

Continues on next page

4.8.1 Replacing the axis-1 gearbox (IRB 6700 - 235/2.65, IRB 6700 - 205/2.80, IRB 6700 - 175/3.05, IRB 6700 - 150/3.20, IRB 6700 - 200/2.60, IRB 6700 - 155/2.85)

Continued

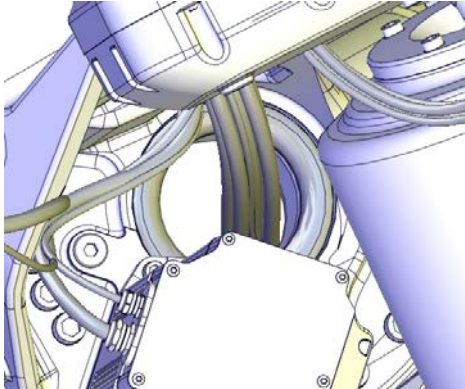
	Action	Note
2	Pull out the robot cable harness through the protection tube.	 <p>xx1300000732</p>
3	Place the cable harness over the balancing device.	

Lifting away the complete arm system

Use this procedure to lift away the complete arm system.

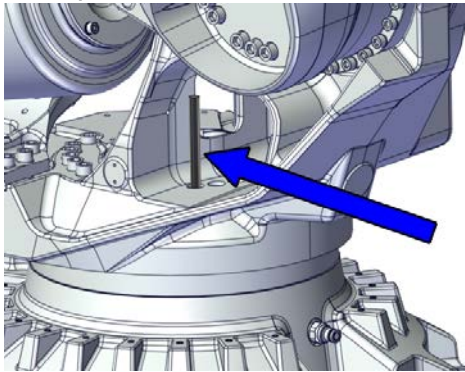
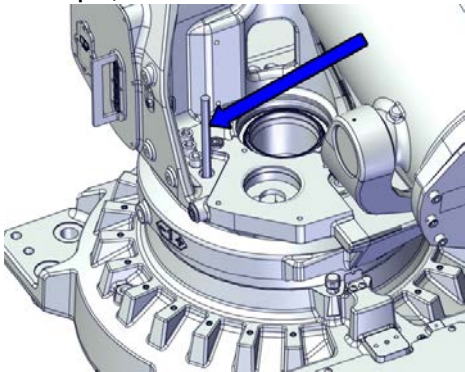

	Action	Note
1	<p>Raise the overhead crane to stretch the chains and roundslings. Make sure that the roundsliding between the wrist and the frame is stretched.</p>	
2	<p>Remove two attachment screws in opposite holes and replace them with guide pins.</p> <p> Tip</p> <p>Lubricate the guide pins with some grease to make the frame slide better.</p>	<p>Guide pin, M16x150: 3HAC13120-2</p>  <p>xx1700001635</p> <p>Guide pin, M16x200: 3HAC13120-3</p>  <p>xx1700001636</p> <p>Always use guide pins in pairs.</p>

Continues on next page

4 Repair

4.8.1 Replacing the axis-1 gearbox (IRB 6700 - 235/2.65, IRB 6700 - 205/2.80, IRB 6700 - 175/3.05, IRB 6700 - 150/3.20, IRB 6700 - 200/2.60, IRB 6700 - 155/2.85)

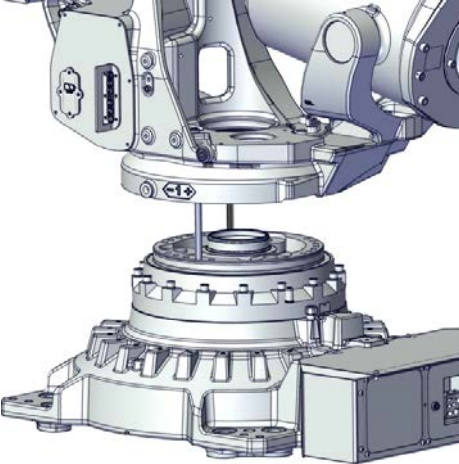
Continued

	Action	Note
3	Remove the remaining attachment screws, that hold the frame to the axis-1 gearbox.	
4	 CAUTION The complete arm system weighs: 1100 kg. All lifting accessories used must be sized accordingly.	
5	Use caution and lift the complete arm system.	 <p data-bbox="943 1086 1050 1108">xx1700001637</p>
6	Move away the complete arm system.	
7	 DANGER Make sure that the complete arm system is resting completely stable on the floor before removing the lifting accessories. Do not change the position of the axes from the position described earlier.	



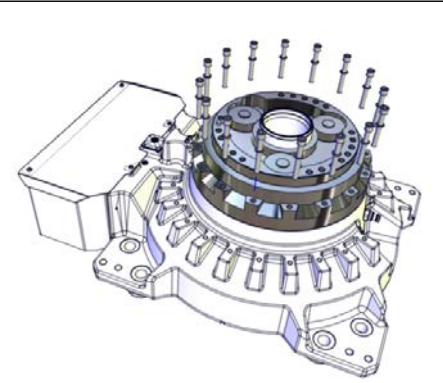

Removing the gearbox

	Action	Note
1	Remove the attachment screws and washers that secure the gearbox to the base.	 <p data-bbox="959 1960 1066 1982">xx1200001186</p>

Continues on next page

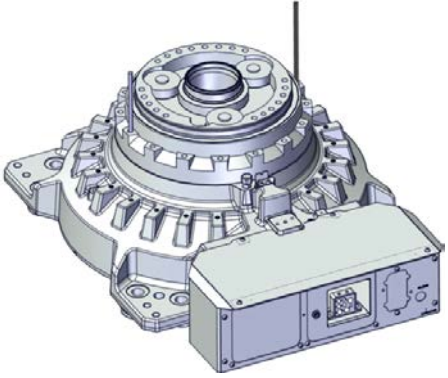
4.8.1 Replacing the axis-1 gearbox (IRB 6700 - 235/2.65, IRB 6700 - 205/2.80, IRB 6700 - 175/3.05, IRB 6700 - 150/3.20, IRB 6700 - 200/2.60, IRB 6700 - 155/2.85)

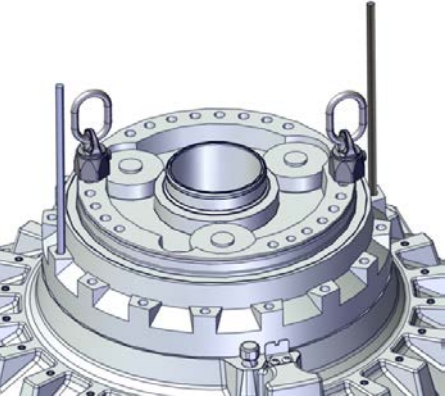
Continued



	Action	Note
2	<p>Fit two guide pins in opposite holes.</p>  <p>Tip</p> <p>Lubricate the guide pins with some grease to make the gearbox slide better.</p>	<p>Guide pin, M12x150: 3HAC13056-2 Guide pin, M12x200: 3HAC13056-3</p>  <p>xx1700001653</p> <p>Always use guide pins in pairs.</p>
3	<p>Fit two lifting eyes manually in opposite holes in the gearbox.</p>  <p>CAUTION</p> <p>Leave a couple of millimeters of space between the lug and the surface of the gearbox. The surface of the gearbox is a sealing surface, not to be damaged.</p>	<p>Lifting eye: 3HAC14457-4</p>  <p>xx1700002193</p>
4	 <p>CAUTION</p> <p>The weight of the gearbox is 92 kg (IRB 6700 -235/2.65, -205/2.80, -175/3.05, -150/3.20, -200/2.60, -155/2.85) 140 kg (IRB 6700 -300/2.70, -245/3.00) All lifting accessories used must be sized accordingly.</p>	

Continues on next page

4 Repair

4.8.1 Replacing the axis-1 gearbox (IRB 6700 - 235/2.65, IRB 6700 - 205/2.80, IRB 6700 - 175/3.05, IRB 6700 - 150/3.20, IRB 6700 - 200/2.60, IRB 6700 - 155/2.85)

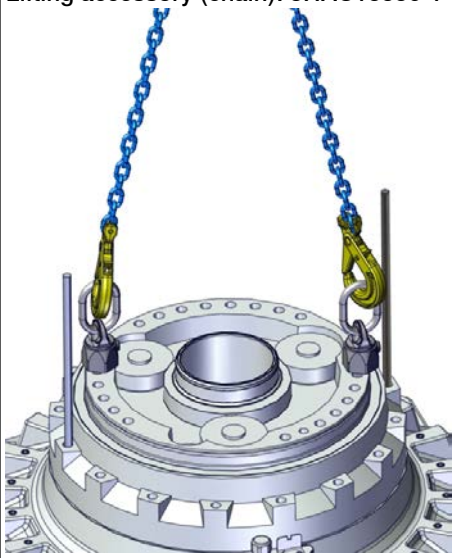
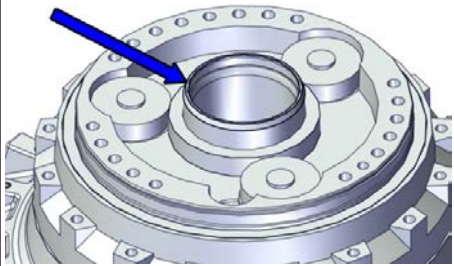
Continued

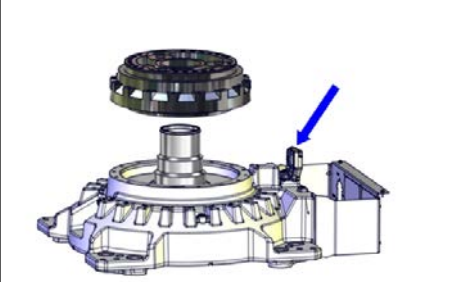
Action	Note
5 Attach the lifting accessory (chain) to the gearbox.	<p>Lifting accessory (chain): 3HAC15556-1</p>  <p>xx1700002194</p>
6 Protect the sealing areas on top of the protection tube, to avoid damaging them.	 <p>xx1700001655</p>
7 Lift away the gearbox.  WARNING When the gearbox is lifted, make sure not to damage the Pendulum Calibration bracket.	 <p>xx1400001983</p>

Continues on next page

4.8.1 Replacing the axis-1 gearbox (IRB 6700 - 235/2.65, IRB 6700 - 205/2.80, IRB 6700 - 175/3.05, IRB 6700 - 150/3.20, IRB 6700 - 200/2.60, IRB 6700 - 155/2.85)



Continued

Refitting the axis-1 gearbox

These procedures describe how to refit the axis-1 gearbox.

Preparations of robot base

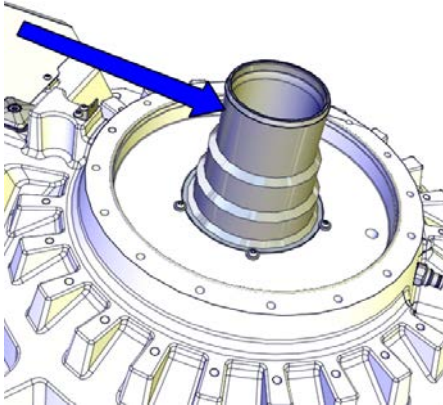
Use this procedure to do the necessary preparations before refitting the gearbox.

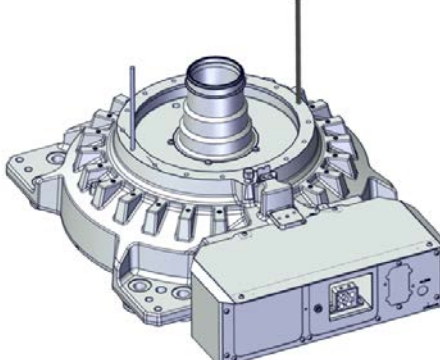
	Action	Note
1	<p>Check the protection tube for damages. Especially check the surface for the radial sealing. See figure! Replace if damaged.</p>	 <p>xx130000779</p>
2	<p>Fit guide pins in opposite holes in the base.</p> <p> Tip</p> <p>Lubricate the guide pins with some grease to make the gearbox slide better.</p>	<p>Guide pin, M12x150: 3HAC13056-2 Guide pin, M12x200: 3HAC13056-3 Always use guide pins in pairs.</p>  <p>xx1700001642</p>
3	<p>Wipe clean the contact surfaces on the base and the surfaces of the protection tube from any contamination.</p>	
4	<p>Put grease on the protection tube.</p>	

Continues on next page





4 Repair

4.8.1 Replacing the axis-1 gearbox (IRB 6700 - 235/2.65, IRB 6700 - 205/2.80, IRB 6700 - 175/3.05, IRB 6700 - 150/3.20, IRB 6700 - 200/2.60, IRB 6700 - 155/2.85)

Continued

Preparations of gearbox





Use this procedure to do the necessary preparations before refitting the gearbox.

	Action	Note
1	<p>Fit two lifting eyes manually in opposite holes in the gearbox.</p> <p> CAUTION</p> <p>Leave a couple of millimeters of space between the lug and the surface of the gearbox. The surface of the gearbox is a sealing surface, not to be damaged.</p>	<p>Lifting eye: 3HAC14457-4</p>  <p>xx1700002190</p>
2	<p>Attach the lifting accessory (chain).</p>	<p>Lifting accessory (chain): 3HAC15556-1</p>  <p>xx1700002191</p>
3	<p> CAUTION</p> <p>The weight of the gearbox is 92 kg (IRB 6700 -235/2.65, -205/2.80, -175/3.05, -150/3.20, -200/2.60, -155/2.85) 140 kg (IRB 6700 -300/2.70, -245/3.00) All lifting accessories used must be sized accordingly.</p>	

Continues on next page

4.8.1 Replacing the axis-1 gearbox (IRB 6700 - 235/2.65, IRB 6700 - 205/2.80, IRB 6700 - 175/3.05, IRB 6700 - 150/3.20, IRB 6700 - 200/2.60, IRB 6700 - 155/2.85)

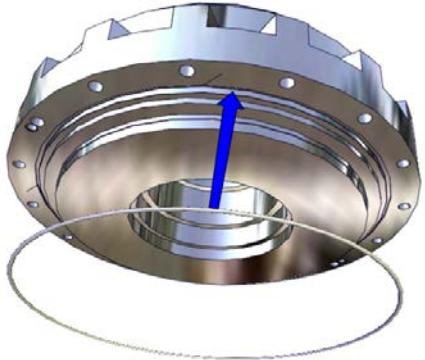
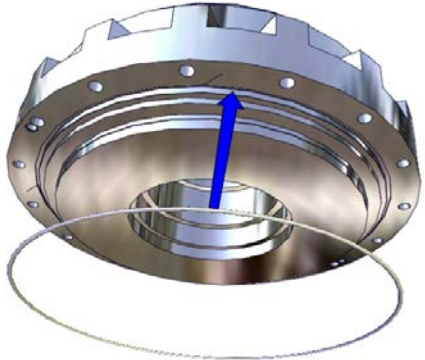
Continued

Action	Note
<p>4 Wipe clean the contact surfaces from any contamination. Also wipe clean the o-ring groove.</p>	 <p>xx1200001245</p>
<p>5 Wipe clean and put some grease on a new o-ring.</p> <p> Note Do not reuse an old o-ring!</p>	<p>O-ring, nitrile rubber: 3HAB3772-93.</p> 
<p>6 Fit the o-ring in the groove of the gearbox.</p>	 <p>xx1200001244</p>
<p>7 Wipe clean the surfaces of the hole in axis-1 gearbox.</p>	 <p>xx1700002192</p>



Continues on next page

4 Repair

4.8.1 Replacing the axis-1 gearbox (IRB 6700 - 235/2.65, IRB 6700 - 205/2.80, IRB 6700 - 175/3.05, IRB 6700 - 150/3.20, IRB 6700 - 200/2.60, IRB 6700 - 155/2.85)

Continued

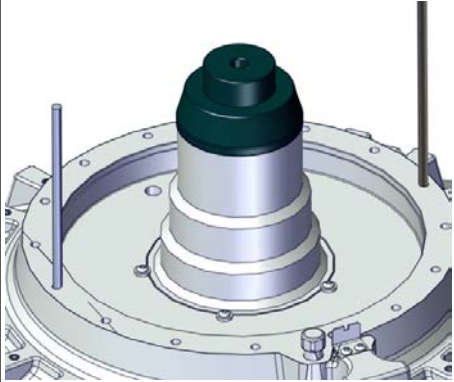
Refitting the gearbox to the base

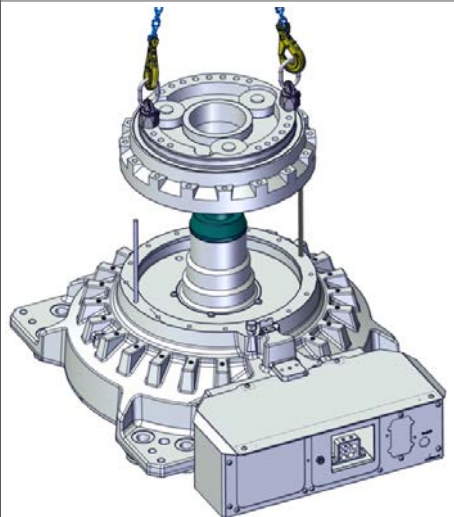
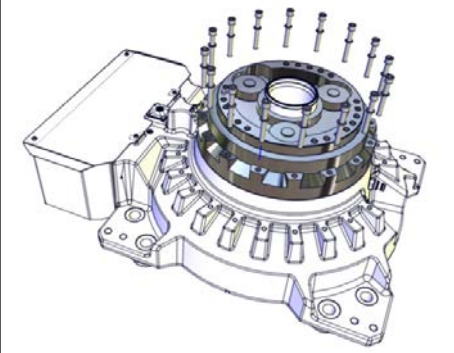
	Action	Note
1	<p>Fit the guide for the gear on top of the protection tube. It protects the protection tube from getting damaged when the gearbox is being fitted.</p>	<p>Guide for reduction gear: 3HAC043870-009.</p>  <p>xx1700002037</p>
2	<p>Lower the gearbox very carefully onto the guide pins and onto the protection tube.</p> <p> Note Make sure that the o-ring is still fitted correctly when the gearbox is being fitted.</p>	 <p>xx1700001641</p>
3	<p>Remove the guide pins.</p>	
4	<p>Remove the lifting accessory and the lifting eyes.</p>	
5	<p>Fit the attachment screws and washers. Tighten by hand.</p>	 <p>xx1200001186</p> <p>Attachment screws: M12x90 (16 pcs)</p>

Continues on next page

4.8.1 Replacing the axis-1 gearbox (IRB 6700 - 235/2.65, IRB 6700 - 205/2.80, IRB 6700 - 175/3.05, IRB 6700 - 150/3.20, IRB 6700 - 200/2.60, IRB 6700 - 155/2.85)

Continued

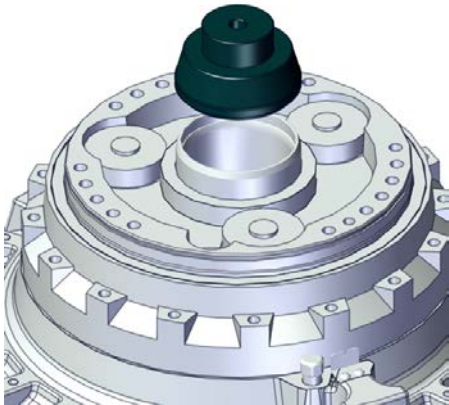
	Action	Note
6	Torque tighten all screws.	Tightening torque: 120 Nm.
7	Remove the guide for the reduction gear.	 <p data-bbox="986 779 1093 801">xx1700002038</p>

Preparations before refitting the arm system

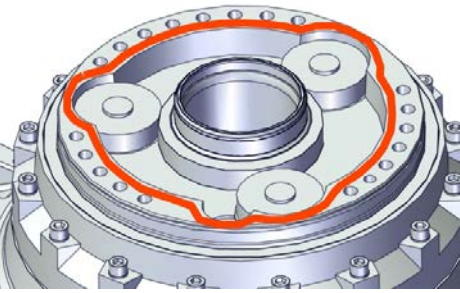

	Action	Note
1	Remove old residues of flange sealant and other contamination from the contact surfaces on the gearbox.	
2	Wipe clean the contact surfaces from any remaining contamination.	
3	Apply flange sealant on the contact surface of the gearbox.	<p data-bbox="970 1120 1300 1153">Flange sealant: - (Loctite 574)</p>  <p data-bbox="975 1473 1082 1496">xx1700002198</p>

Continues on next page

4 Repair

4.8.1 Replacing the axis-1 gearbox (IRB 6700 - 235/2.65, IRB 6700 - 205/2.80, IRB 6700 - 175/3.05, IRB 6700 - 150/3.20, IRB 6700 - 200/2.60, IRB 6700 - 155/2.85)

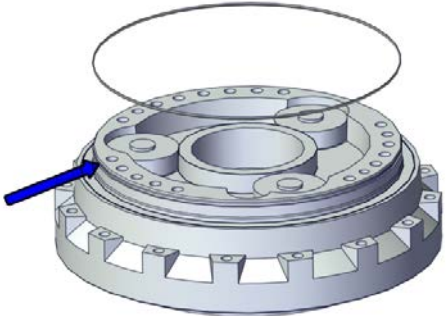
Continued

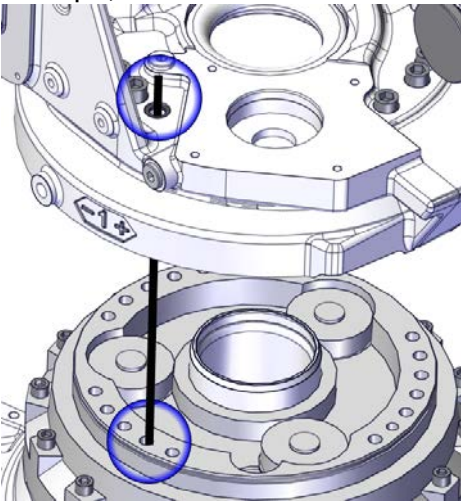
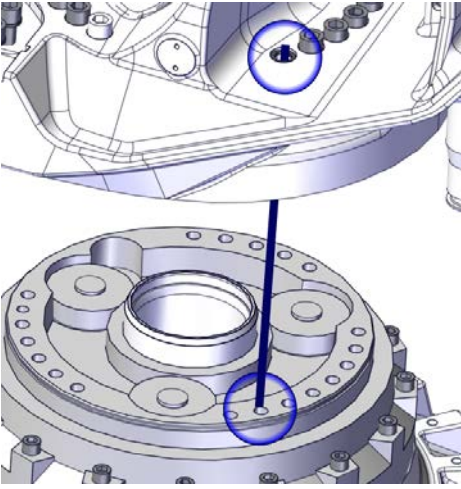
	Action	Note
4	Wipe clean the o-ring groove in the gearbox and the new o-ring.	O-ring, nitrile rubber: 3HAB3772-164 or 3HAC061327-002 (depends on gearbox variant, see <i>Product manual, spare parts - IRB 6700</i>).
5	Lubricate the new o-ring with grease and fit it to the gearbox.	Grease: 3HAC042536-001.  xx1700001658
6	Apply guide pins in opposite holes in the gearbox.  Note Make sure that the guide pins are fitted in the correct holes in the gearbox. See figures!  Tip Lubricate the guide pins with some grease to make the frame slide better.	Guide pin, M16x200: 3HAC13120-3  xx1300000823 Guide pin, M16x150: 3HAC13120-2  xx1300000822 Always use guide pins in pairs.

Continues on next page

4.8.1 Replacing the axis-1 gearbox (IRB 6700 - 235/2.65, IRB 6700 - 205/2.80, IRB 6700 - 175/3.05, IRB 6700 - 150/3.20, IRB 6700 - 200/2.60, IRB 6700 - 155/2.85)

Continued

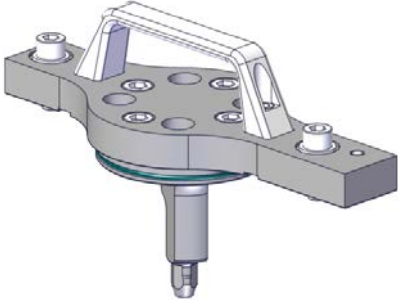
	Action	Note
7	<p>Prepare the aligning tool.</p> <ol style="list-style-type: none"> 1 Put some grease on the o-ring of the aligning tool. 2 Put some grease on the part of the aligning tool that will mate with the hole in the gearbox. 3 Also put some grease in the matching hole in the gearbox. <p>The aligning tool is now prepared to be fitted. Wait until the arm system is lifted into position and the arm system orientation is verified visually before fitting the tool.</p>	<p>Aligning tool: 3HAC046645-003</p> <p>Used for aligning the gearbox against the frame, so that the play in the motor does not need to be adjusted.</p>  <p>xx1700001659</p>

Refitting the arm system

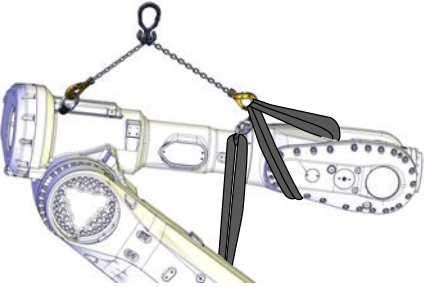

	Action	Note
1	 CAUTION The arm system weighs 1100 kg. All lifting accessories used must be sized accordingly.	
2	Make sure that all lifting accessories still is fitted correctly on the arm system.	
3	Attach the upper arm lifting accessory (chain) to an overhead crane (or similar) and then to the lifting eye in the arm house and to a roundsling run through the wrist.	<p>For a more detailed description see Attaching the lifting accessories on page 570.</p> <p>Lifting accessory (chain): 3HAC15556-1 Roundsling, 1 m: Length: 1 m, lifting capacity: 1,000 kg.</p>  <p>xx1200001236</p>
4	Lift the arm system up to reach the contact surfaces underneath the frame.	
5	Remove old residues of flange sealant from the contact surfaces.	
6	Wipe clean the contact surfaces from any remaining contamination. Also wipe clean the o-ring groove.	

Continues on next page

4 Repair

4.8.1 Replacing the axis-1 gearbox (IRB 6700 - 235/2.65, IRB 6700 - 205/2.80, IRB 6700 - 175/3.05, IRB 6700 - 150/3.20, IRB 6700 - 200/2.60, IRB 6700 - 155/2.85)

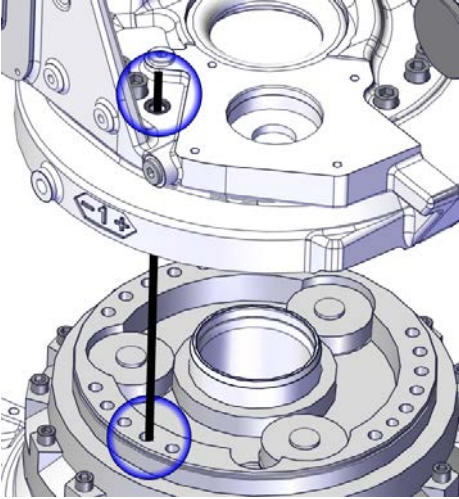
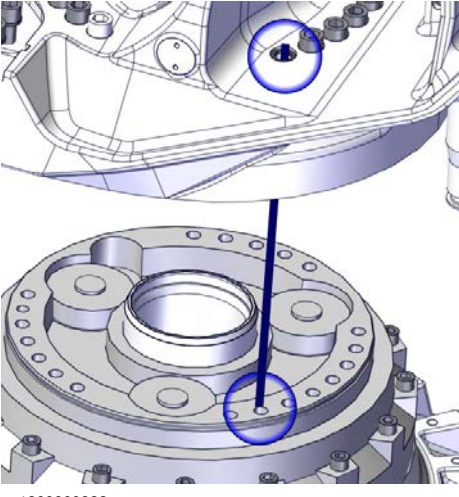
Continued

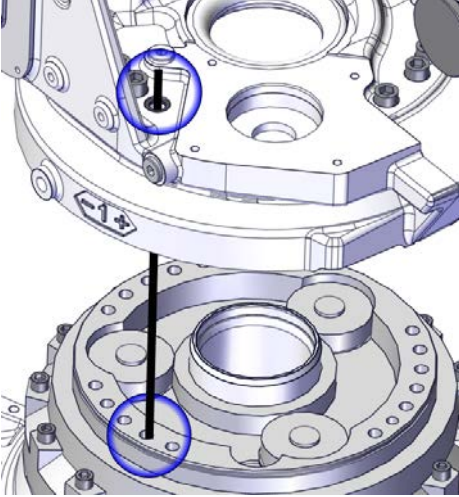
	Action	Note
7	<p>Lift the arm system to mounting position, and verify that the hole pattern match and that the guide pins will enter the correct holes in the frame.</p> <p> Note</p> <p>The amount of screw holes differ between the frame and the gearbox. See figures for correct entering holes for the guide pins.</p>	<p>Position of Guide pin, M16x200:</p>  <p>xx130000823</p> <p>Position of Guide pin, M16x150:</p>  <p>xx130000822</p>
8	<p>Lower the arm system to align the longest guide pin into the hole.</p> <p> Note</p> <p>The outer screw hole in the gearbox (next to the motor pinion hole) is not used.</p>	<p>Position of Guide pin, M16x200:</p>  <p>xx130000823</p>

Continues on next page

4.8.1 Replacing the axis-1 gearbox (IRB 6700 - 235/2.65, IRB 6700 - 205/2.80, IRB 6700 - 175/3.05, IRB 6700 - 150/3.20, IRB 6700 - 200/2.60, IRB 6700 - 155/2.85)

Continued

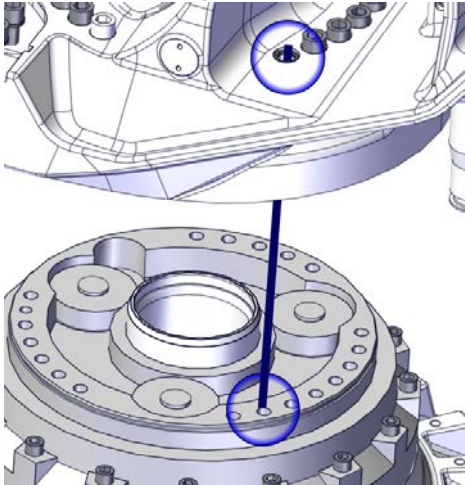
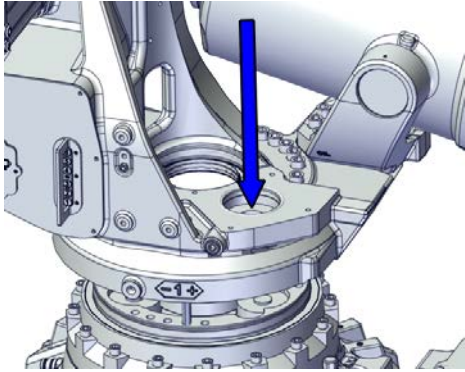
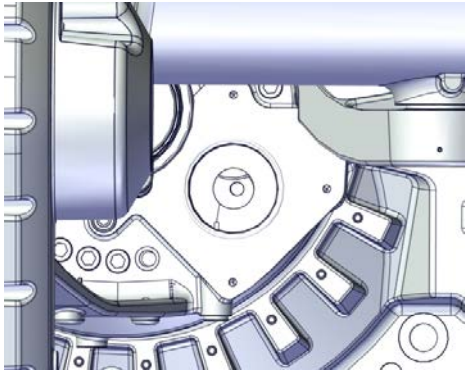

	Action	Note
9	Lower the arm system to align the other guide pin into the hole.	<p>Position of Guide pin, M16x150:</p>  <p>xx1300000822</p>
10	Visually verify through the axis-1 motor hole that the hole is aligned with the pinion hole in the gearbox.	 <p>xx1700002040</p>  <p>xx1700002041</p>

Continues on next page

4 Repair

4.8.1 Replacing the axis-1 gearbox (IRB 6700 - 235/2.65, IRB 6700 - 205/2.80, IRB 6700 - 175/3.05, IRB 6700 - 150/3.20, IRB 6700 - 200/2.60, IRB 6700 - 155/2.85)

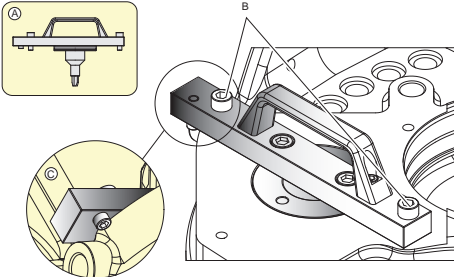
Continued

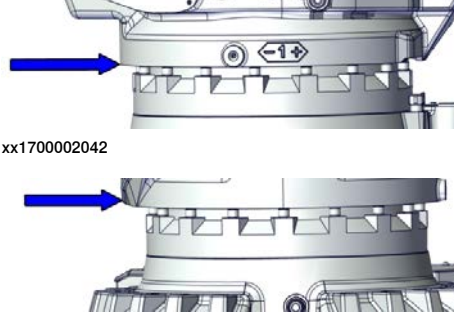

	Action	Note
11	Fit the aligning tool according to figure.	 <p>xx1300001118</p> <p>A Aligning tool B Attachment screws (2 pcs) C Correct fitting of the aligning tool.</p> <p>Tightening torque: 24 Nm.</p>
12	<p>Lower the arm system slowly until the heads of the gearbox attachment screws are starting to disappear inside the frame edge.</p> <p>Verify visually from the side and from the front/back that the frame is coming down completely level against the gearbox. If the frame is somewhat tilted, adjust the lifting position with the overhead crane.</p> <p> Note</p> <p>While lowering the complete arm system, check that the cylindrical pin is fitted correctly.</p>	 <p>xx1700002042</p> <p>xx1700002043</p>
13	When the arm system is in position, fit the accessible attachment screws manually (no tools).	Attachment screws: M16x110 (16 pcs)
14	Use caution and lower the complete arm system into position on top of the gearbox.	
15	Secure the complete arm system to the axis-1 gearbox with its attachment screws.	Tightening torque: 300 Nm.
16	Remove the two guide pins and replace with attachment screws. Tighten the remaining, accessible attachment screws.	Tightening torque: 300 Nm.
17	Perform a leak-down test.	See Performing a leak-down test on page 186 .
18	Remove the aligning tool, after the leak-down test is completed successfully.	
19	Remove the lifting accessories.	

Continues on next page

4.8.1 Replacing the axis-1 gearbox (IRB 6700 - 235/2.65, IRB 6700 - 205/2.80, IRB 6700 - 175/3.05, IRB 6700 - 150/3.20, IRB 6700 - 200/2.60, IRB 6700 - 155/2.85)

Continued

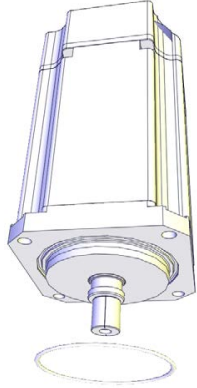
Preparations prior to refitting motor

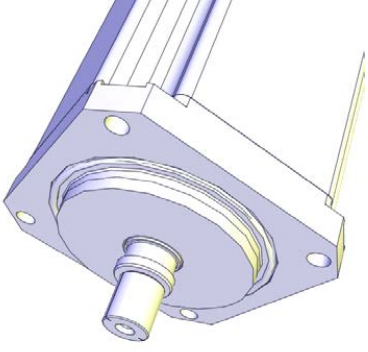
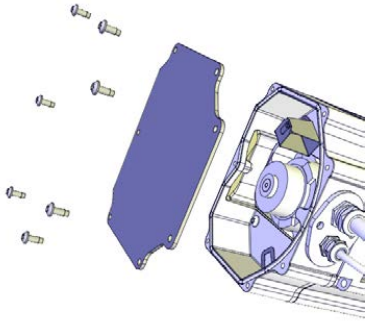
	Action	Note
1	 <p>DANGER</p> <p>Make sure that all supplies for electrical power, hydraulic pressure, and air pressure are turned off.</p>	
2	<p>Remove any old paint residues or other contamination from the contact surfaces on both the motor and the mating parts.</p> <p>Wipe clean the contact surfaces and the o-ring groove.</p>	
3	<p>Fit a new o-ring.</p>	 <p>xx1200001019</p>
4	 <p>Tip</p> <p>Lubricate the o-ring with some grease for a better fitting in the groove.</p>	 <p>xx1200001020</p>
5	<p>If the motor is a new spare part, remove the cover.</p>	 <p>xx1200001135</p>



Continues on next page

4 Repair

4.8.1 Replacing the axis-1 gearbox (IRB 6700 - 235/2.65, IRB 6700 - 205/2.80, IRB 6700 - 175/3.05, IRB 6700 - 150/3.20, IRB 6700 - 200/2.60, IRB 6700 - 155/2.85)

Continued

Securing the axis-1 motor

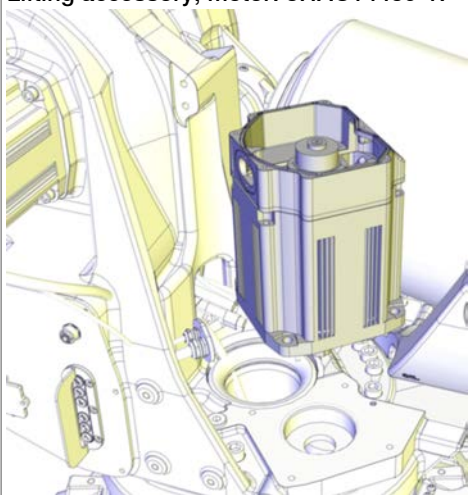
	Action	Note
1	Fit guide pins in opposite holes.	Guide pin, M10x150: 3HAC15521-2 Always use guide pins in pairs.
2	 CAUTION The motor weighs 25 kg. All lifting accessories used must be sized accordingly.	
3	Apply the lifting accessory.	Lifting accessory, motor: 3HAC14459-1.
4	Fit the rotation tool.	Rotation tool: 3HAB7887-1
5	Connect the 24 VDC power supply to release the brakes. To release the brakes, connect the 24 VDC power supply as described in the list. Connect to R2.MP1-connector: <ul style="list-style-type: none"> • + = pin 2 • - = pin 5 	
6	 CAUTION Whenever parting/mating motor and gearbox, the gears may be damaged if excessive force is used.	
7	Lower the motor into position. <ul style="list-style-type: none"> • Make sure that the motor pinion is properly mated to the gear in the gearbox. • Make sure that the motor pinion does not get damaged. • Make sure that the direction of the cable gland exit is facing the correct way. 	Lifting accessory (chain): 3HAC15556-1 Lifting accessory, motor: 3HAC14459-1.  xx1200001072

Continues on next page

4.8.1 Replacing the axis-1 gearbox (IRB 6700 - 235/2.65, IRB 6700 - 205/2.80, IRB 6700 - 175/3.05, IRB 6700 - 150/3.20, IRB 6700 - 200/2.60, IRB 6700 - 155/2.85)

Continued

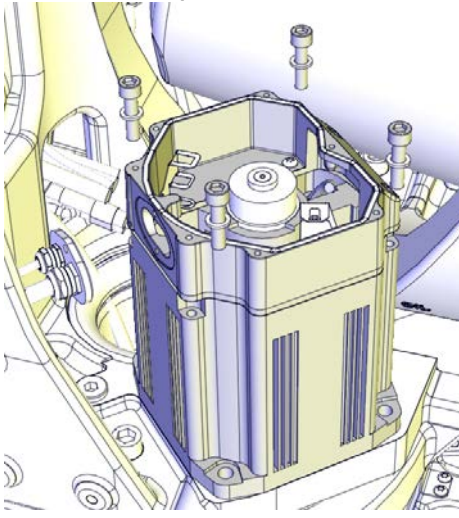
	Action	Note
8	<p>Secure the motor with its attachment screws and washers. Use a bits extender to reach the screws.</p>	<p>Bits extender: 3HAC12342-1 Tightening torque: 50 Nm. Screws: M10x30 Steel 12.9 Gle 603+Geo500 (4 pcs)</p>  <p style="font-size: small;">xx1200001071</p>
9	<p>Perform a leak-down test (if not already done).</p>	<p>See Performing a leak-down test on page 186.</p>
10	<p>Disconnect the 24 VDC power supply.</p>	

Refitting the cable harness in the base

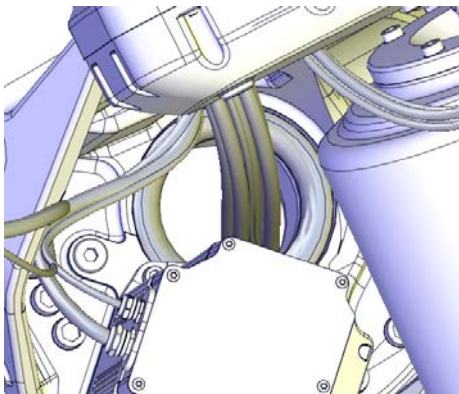
	Action	Note
1	<p>Run the cables through the protection tube in this order:</p> <ul style="list-style-type: none"> • R1.MP • R1.SMB <p>If necessary, lubricate the cables with grease to make them run more smoothly.</p>	 <p style="font-size: small;">xx1300000732</p>

Continues on next page

4 Repair

4.8.1 Replacing the axis-1 gearbox (IRB 6700 - 235/2.65, IRB 6700 - 205/2.80, IRB 6700 - 175/3.05, IRB 6700 - 150/3.20, IRB 6700 - 200/2.60, IRB 6700 - 155/2.85)

Continued

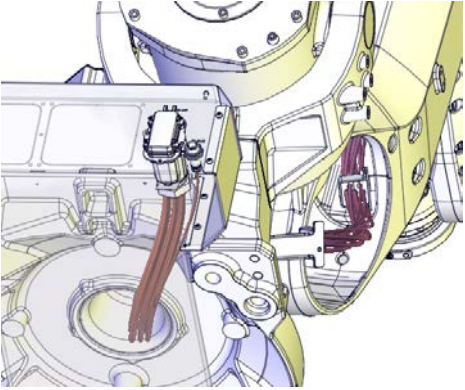
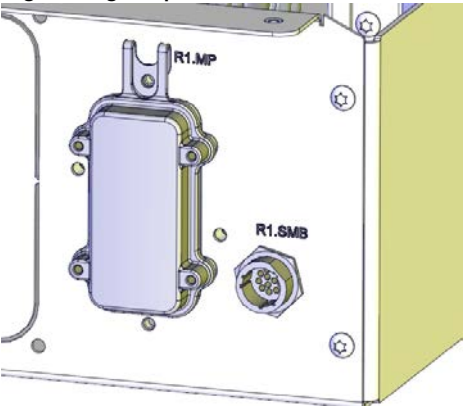
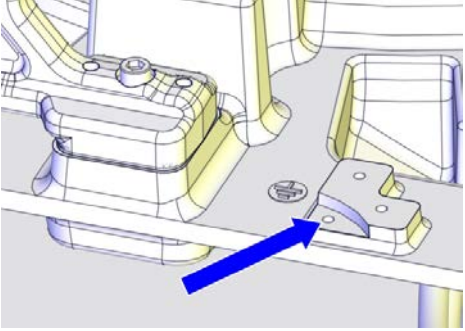
	Action	Note
2	<ul style="list-style-type: none"> Make sure that the cables are not twisted. Each cable must be in line with its position on the base plate. Make sure that the R1.SMB cable will run on the correct side of the R1.MP1, see the figure. 	 <p>xx1300000736</p>
3	Make sure that the markings on the cables are facing the base cover, when connected.	
4	Connect connectors R1.MP and R1.SMB.	<p>Tightening torque for R1.SMB: 10 Nm.</p>  <p>xx1300000591</p>
5	Connect the earth cable.	<p>Screw dimension: M6x16. Washer dimension: 6.4x17x3.</p>  <p>xx1400000354</p>
6	If used, run the DressPack cables through the protection tube in the base.	
7	<p>If used, run the DressPack hoses through the protection tube in the base.</p> <p>Make sure that the hoses are running correctly and are not twisted!</p>	

Continues on next page

4.8.1 Replacing the axis-1 gearbox (IRB 6700 - 235/2.65, IRB 6700 - 205/2.80, IRB 6700 - 175/3.05, IRB 6700 - 150/3.20, IRB 6700 - 200/2.60, IRB 6700 - 155/2.85)

Continued

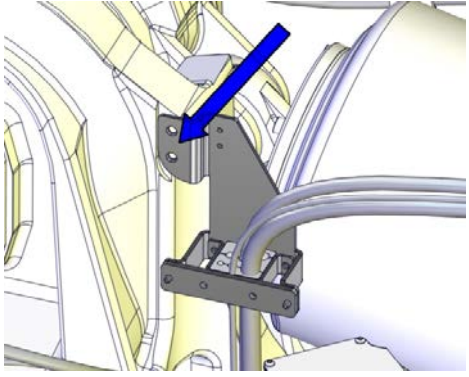
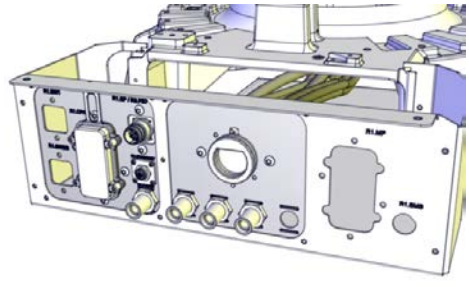
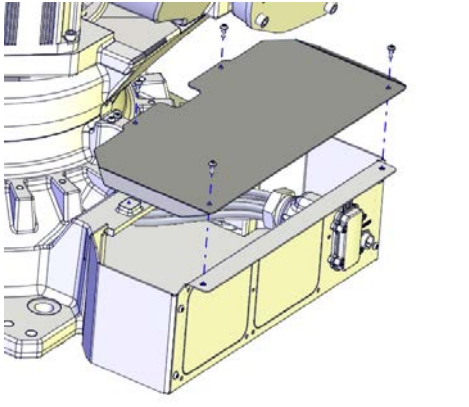
	Action	Note
8	If used, fit the bracket that hold the DressPack to the frame.	 <p>xx140000078</p>
9	If used, connect the DressPack cable package on the base plate.	 <p>xx120000052</p>
10	Refit the base cover.	 <p>xx1300000561</p>



Continues on next page

4 Repair

4.8.1 Replacing the axis-1 gearbox (IRB 6700 - 235/2.65, IRB 6700 - 205/2.80, IRB 6700 - 175/3.05, IRB 6700 - 150/3.20, IRB 6700 - 200/2.60, IRB 6700 - 155/2.85)

Continued

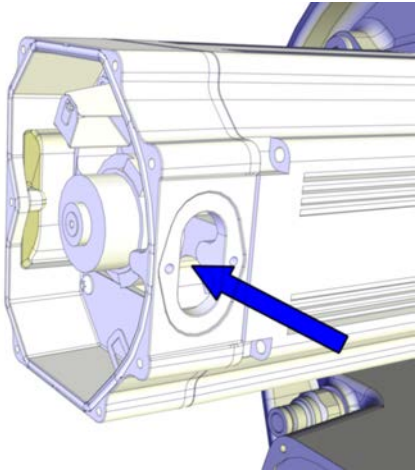

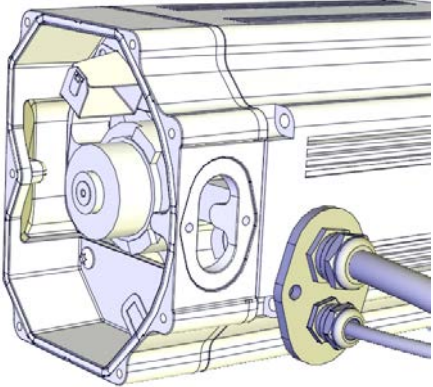
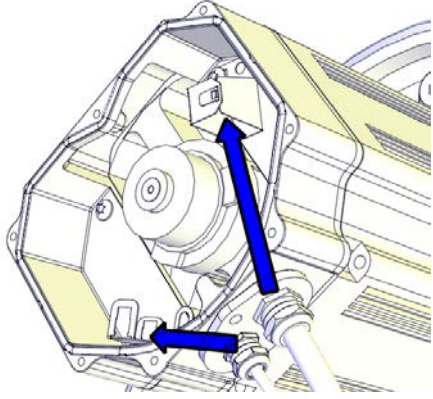
Connecting the axis-1 motor cables

	Action	Note
1	Push the motor cables through the cable gland opening.	 xx130000738
2	Refit the cable gland cover.  Note Replace the gasket if damaged.	 xx1200001067
3	Connect the motor cables. Connect in accordance with the markings on the connectors.	 xx1200001066

Continues on next page

4.8.1 Replacing the axis-1 gearbox (IRB 6700 - 235/2.65, IRB 6700 - 205/2.80, IRB 6700 - 175/3.05, IRB 6700 - 150/3.20, IRB 6700 - 200/2.60, IRB 6700 - 155/2.85)

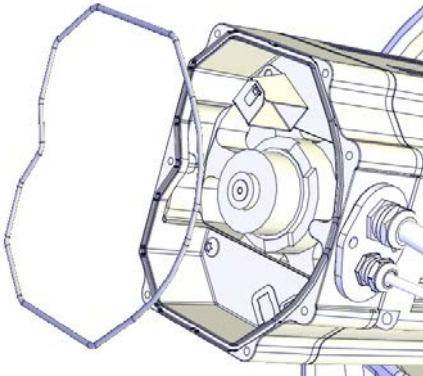
Continued



	Action	Note
4	<p>Inspect the o-ring.</p> <p> Note</p> <p>Replace if damaged.</p>	<p>O-ring, axis-1: 3HAB3772-111 (circular profile) / 3HAC054692-002 (hexagon profile)</p> <p>O-ring, axis-2: 3HAB3772-111 (circular profile) / 3HAC054692-002 (hexagon profile)</p> <p>O-ring, axis-3: 3HAB3772-111 (circular profile) / 3HAC054692-002 (hexagon profile)</p> <p>O-ring, axis-4: 3HAB3772-110 (circular profile) / 3HAC054692-001 (hexagon profile)</p> <div style="text-align: right;">  </div> <p style="text-align: right; font-size: small;">xx1200001070</p>
5	<p>Wipe clean o-ring and o-ring groove.</p>	
6	<p>Refit the o-ring.</p> <p> Tip</p> <p>Lubricate the o-ring with some grease for a better fitting in the groove.</p>	
7	<p> CAUTION</p> <p>When fitting the motor cover, make sure that none of the cables inside will be damaged.</p>	

Continues on next page

4 Repair

4.8.1 Replacing the axis-1 gearbox (IRB 6700 - 235/2.65, IRB 6700 - 205/2.80, IRB 6700 - 175/3.05, IRB 6700 - 150/3.20, IRB 6700 - 200/2.60, IRB 6700 - 155/2.85)

Continued

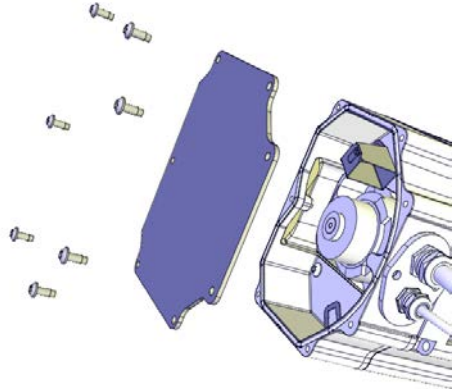
	Action	Note
8	<p>Refit the motor cover with its attachment screws.</p> <p> Note</p> <p>Do not reuse the self-threading attachment screws. Replace with standard attachment screws or the threads will be damaged.</p> <p> Note</p> <p>Make sure the o-ring is undamaged and properly fitted.</p>	<p>Attachment screws: M5x12 8.8 (7 pcs)</p>  <p>xx1200001135</p>
9	<p>Make sure that the covers are tightly sealed.</p>	

Concluding procedure

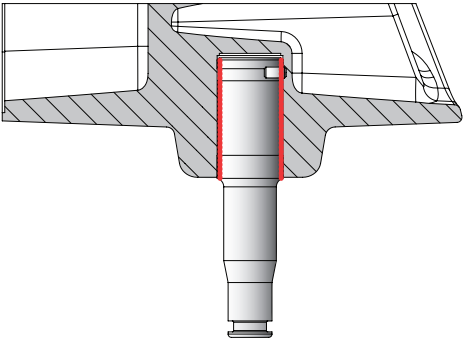
	Action	Note
1	<p>Turn on the power to the robot and jog to:</p> <ul style="list-style-type: none"> • axis 1 = -5° • axis 2 = +10° 	
2	<p> DANGER</p> <p>Turn off all:</p> <ul style="list-style-type: none"> • electric power supply • hydraulic pressure supply • air pressure supply <p>to the robot, before entering the robot working area.</p>	
3	<p>Refill oil in the gearbox.</p>	<p>See Filling oil into the axis-1 gearbox on page 150.</p>
4	<p>Foundry Plus:</p> <p>Apply Mercasol on the surfaces shown in the figure, on stop pin and in the hole as shown in the figure.</p>	<p>Rust preventive: 3HAC034903-001 (Mercasol 3110 Waxcoat. Recommended drying time is 24h.).</p>  <p>xx1400000378</p>

Continues on next page

4.8.1 Replacing the axis-1 gearbox (IRB 6700 - 235/2.65, IRB 6700 - 205/2.80, IRB 6700 - 175/3.05, IRB 6700 - 150/3.20, IRB 6700 - 200/2.60, IRB 6700 - 155/2.85)

Continued

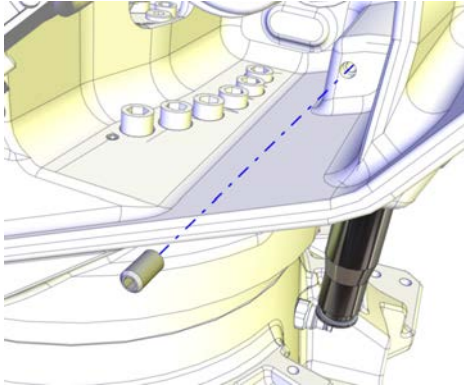
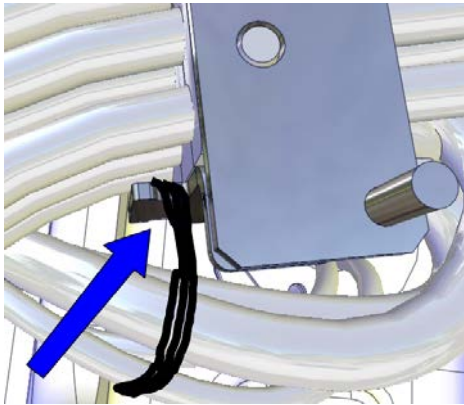
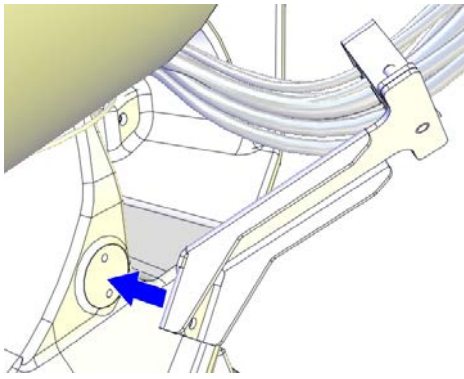
	Action	Note
5	Refit the mechanical stop pin and secure it with the attachment screw. Apply locking liquid on the screw.	Locking liquid: 3HAB7116-1 (Loctite 243). Tightening torque: 24 Nm  xx1300000476
6	Secure the cable harness inside the frame recess with a cable strap.	 xx1200001237
7	Refit the cable bracket on the frame.	 xx1200001246
8	Re-calibrate the robot.	Pendulum Calibration is described in <i>Operating manual - Calibration Pendulum</i> , enclosed with the calibration tools. Axis Calibration is described in Calibrating with Axis Calibration method on page 781 . General calibration information is included in section Calibration on page 767 .

Continues on next page

4 Repair

4.8.1 Replacing the axis-1 gearbox (IRB 6700 - 235/2.65, IRB 6700 - 205/2.80, IRB 6700 - 175/3.05, IRB 6700 - 150/3.20, IRB 6700 - 200/2.60, IRB 6700 - 155/2.85)

Continued

	Action	Note
9	 DANGER Make sure all safety requirements are met when performing the first test run.	

4.8.2 Replacing the axis-1 gearbox (IRB 6700 - 300/2.70, IRB 6700 - 245/3.00)

Validity of this section - variant



Note

This section describes how to replace the gearbox on variants IRB 6700 - 300/2.70, IRB 6700 - 245/3.00.

How to replace the gearbox on variants IRB 6700 - 235/2.65, IRB 6700 - 205/2.80, IRB 6700 - 175/3.05, IRB 6700 - 150/3.20, IRB 6700 - 200/2.60, IRB 6700 - 155/2.85 see [Replacing the axis-1 gearbox \(IRB 6700 - 235/2.65, IRB 6700 - 205/2.80, IRB 6700 - 175/3.05, IRB 6700 - 150/3.20, IRB 6700 - 200/2.60, IRB 6700 - 155/2.85\)](#) on page 564.

Location of the axis-1 gearbox

The axis-1 gearbox is located as shown in the figure.

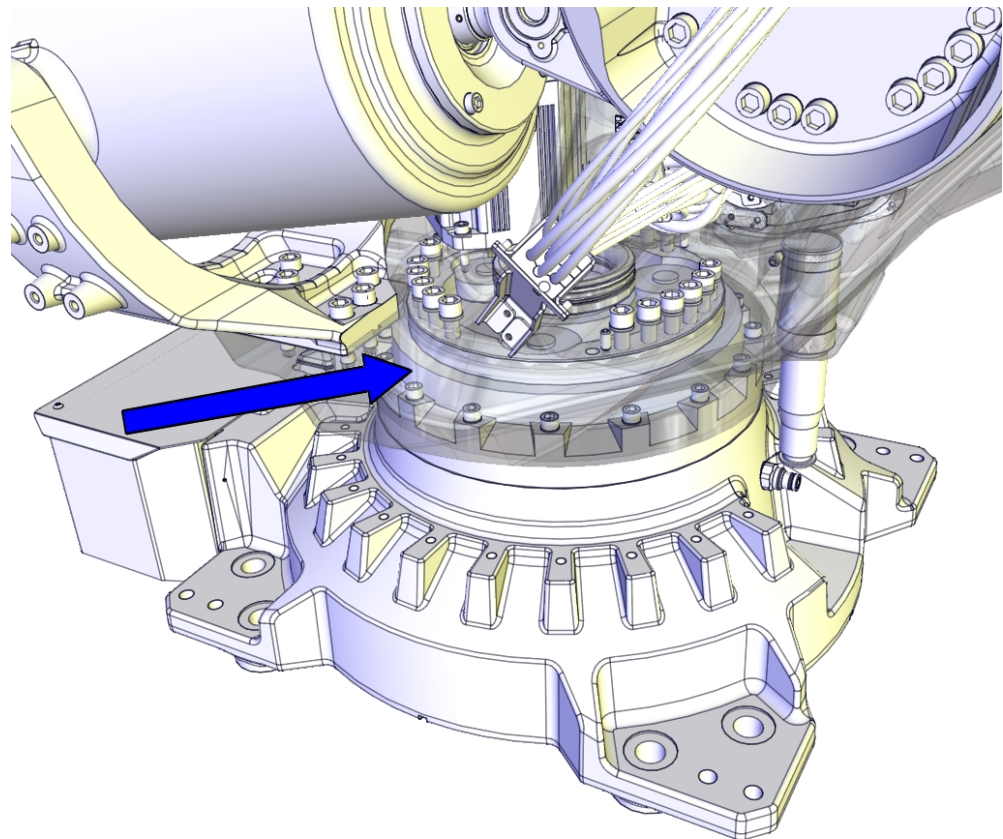

xx1200001183

Summary of the replacement procedure

This is a brief summary of the replacement procedure, containing the major actions to be performed.

- 1 Drain the axis-1 gearbox.
- 2 Remove the cabling from the base.

Continues on next page

4 Repair

4.8.2 Replacing the axis-1 gearbox (IRB 6700 - 300/2.70, IRB 6700 - 245/3.00)

Continued

- 3 Remove the axis-1 motor.
- 4 Remove the complete arm system (including frame and balancing device) as a package.
- 5 Replace the axis-1 gearbox.
- 6 Refit in reverse order.

Spare parts

Spare parts	Article number	Note
Axis-1 gearbox	See <i>Product manual, spare parts - IRB 6700/IRB 6700Inv.</i>	

Required tools and equipment

Equipment, etc.	Article number	Note
Oil collecting vessel	-	The capacity of the vessel must be sufficient to take the complete amount of oil.
Oil dispenser	-	One example of oil dispenser can be found in section Type of lubrication in gearboxes on page 145 .
Removal tool kit M12 and M14	3HAC057339-002	Used to push out the motor, if necessary. Always use removal tools in pairs. Size depending on motor type, see Type A vs type B motors on page 805 .
Bits extender	3HAC12342-1	300 mm, bits 1/2"
Lifting eye	3HAC16131-1	M12
Lifting eye	3HAC16131-1	M12
Fender washer	-	Outer diameter: minimum 26 mm, maximum 30 mm, hole diameter: 13 mm, thickness: 3 mm.
Lifting shackle	-	SA-10-8-NA1
Roundsling, 1.5 m	-	Length: 1.5 m. Lifting capacity: 2,000 kg.
Roundsling, 1 m	-	Length: 1 m, lifting capacity: 1,000 kg.
Lifting accessory (chain)	3HAC15556-1	Lifting instruction 3HAC15880-2 enclosed.
Lifting eye	3HAC14457-4	M16
Lifting eye	3HAC14457-4	M16
Removal tool kit M12 and M14	3HAC057339-002	Required dimension of removal tool depends on motor type A or B, see Identifying the motor by article number on page 805 Used to push out the motor, if necessary. Always use removal tools in pairs.
Lifting accessory, motor	3HAC14459-1	

Continues on next page

4.8.2 Replacing the axis-1 gearbox (IRB 6700 - 300/2.70, IRB 6700 - 245/3.00)

Continued

Equipment, etc.	Article number	Note
Rotation tool	3HAB7887-1	Used to rotate the motor pinion.
Aligning tool	3HAC046645-003	Used for aligning the gearbox against the frame, so that the play in the motor does not need to be adjusted.
24 VDC power supply	-	Used to release the motor brakes.
Guide pin, M10x150	3HAC15521-2	Always use guide pins in pairs.
Guide pin, M16x120	3HAC062397-001	Always use guide pins in pairs.
Guide pin, M20x180	3HAC048814-002	Always use guide pins in pairs.
Support legs	3HAC15535-1	
Leak-down tester	-	
Calibration Pendulum toolkit	3HAC15716-1	Required if Calibration Pendulum is the valid calibration method for the robot.
Calibration tool box, Axis Calibration	3HAC055412-001	Delivered as a set of calibration tools. Required if Axis Calibration is the valid calibration method for the robot.
Standard toolkit	-	Content is defined in section Standard toolkit on page 814 .

Consumables

Equipment, etc	Article number	Note
Flange sealant	-	Loctite 574
Grease	3HAC042536-001	Shell Gadus S2 Used to lubricate o-rings.
Locking liquid	3HAB7116-1	Loctite 243
O-ring	3HAB3772-160	414.3x5.7. Located between the gearbox and the frame.
O-ring	3HAB3772-97	Located at the oil inlet underneath of gearbox.
O-ring ⁱ	3HAB3772-111 (circular profile) / 3HAC054692-002 (hexagon profile)	D=169.5x3 Used on motor cover.
O-ring	3HAB3772-107	D=102x3 Used on motor flange.
Sealing ring	3HAC047474-001	Located in the frame, on top of the protection tube.
O-ring	3HAB3772-57	Located on the sealing ring.
Radial sealing with dust lip	3HAB3701-51	Located in the frame, underneath the sealing ring.
Cable straps	-	

ⁱ The cross-section profile is either circular or hexagon. If only ordering the o-ring, order the same profile that is currently installed in the connection box.

Continues on next page

4 Repair

4.8.2 Replacing the axis-1 gearbox (IRB 6700 - 300/2.70, IRB 6700 - 245/3.00)

Continued

Required documents

Document name	Document number	Note
<i>Technical reference manual - Lubrication in gearboxes</i>	3HAC042927-001	

Deciding calibration routine

Decide which calibration routine to be used, based on the information in the table. Depending on which routine is chosen, action might be required prior to beginning the repair work of the robot, see the table.

	Action	Note
1	Decide which calibration routine to use for calibrating the robot. <ul style="list-style-type: none">Reference calibration. External cable packages (DressPack) and tools can stay fitted on the robot.Fine calibration. All external cable packages (DressPack) and tools must be removed from the robot.	
	If the robot is to be calibrated with reference calibration: Find previous reference values for the axis or create new reference values. These values are to be used after the repair procedure is completed, for calibration of the robot. If no previous reference values exist, and no new reference values can be created, then reference calibration is not possible.	Follow the instructions given in the reference calibration routine on the FlexPendant to create reference values. Creating new values requires possibility to move the robot. Read more about reference calibration for Axis Calibration in Reference calibration routine on page 782 . Read more about reference calibration for Pendulum Calibration in <i>Operating manual - Calibration Pendulum</i> .
	If the robot is to be calibrated with fine calibration: Remove all external cable packages (DressPack) and tools from the robot.	

Removing the axis-1 gearbox





These procedures describe how to remove the gearbox.

Preparations before removing the axis-1 gearbox

Use this procedure to do the necessary preparations, before removing the gearbox.

	Action	Note
1	Decide which calibration routine to use, and take actions accordingly prior to beginning the repair procedure.	
2	Move the robot to synchronization position.	The axis-1 must be in 0 position to make it possible to remove the mechanical stop pin.

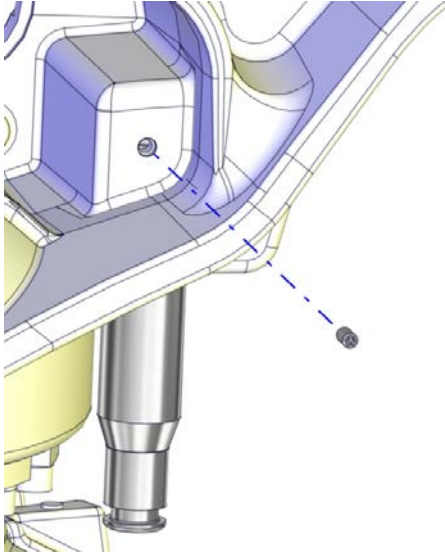
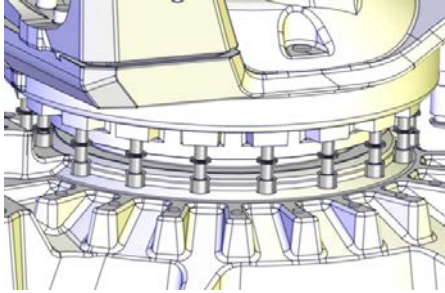
Continues on next page

	Action	Note
3	<p> DANGER</p> <p>Turn off all:</p> <ul style="list-style-type: none"> • electric power supply • hydraulic pressure supply • air pressure supply <p>to the robot, before entering the safeguarded space.</p>	
4	<p>Remove tools and other equipment fitted on the turning disc. DressPack can stay fitted for the time being.</p>	<p>This is done to achieve the best stability of the complete arm system, when it is resting by itself, after it has been removed.</p>
5	<p>Hold the mechanical stop pin in a firm grip, and remove it by unscrewing the attachment screw.</p> <p> CAUTION</p> <p>The mechanical stop weighs 5 kg.</p>	 <p>xx1400002179</p>
6	<p>Begin draining the axis-1 gearbox.</p>	<p>See Draining the axis-1 gearbox on page 148.</p>
7	<p>Loosen 14 of the 18 attachment screws as far as it is possible at this point. The four screws that are left in place, diagonally located to each other, work as an anvil for the axis 1 rotation when unscrewing the hub later on.</p>	 <p>xx1400002169</p> <p> Note</p> <p>It will not be possible to remove the screws completely at this point.</p>

Continues on next page

4 Repair

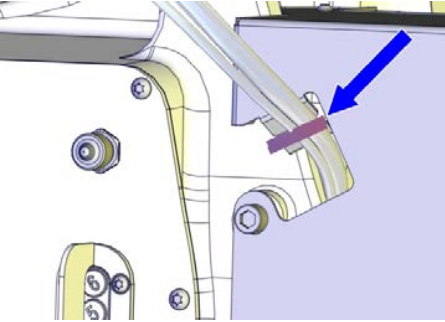
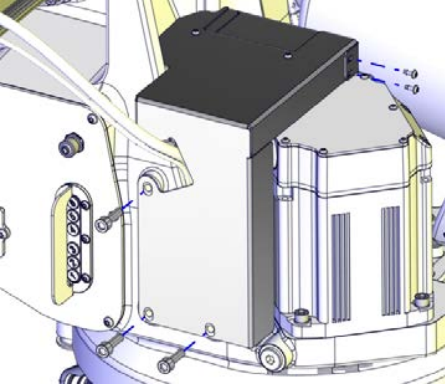
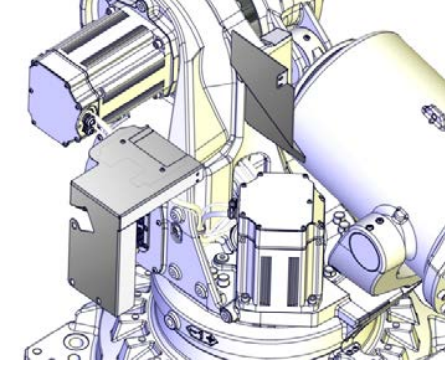

4.8.2 Replacing the axis-1 gearbox (IRB 6700 - 300/2.70, IRB 6700 - 245/3.00)

Continued

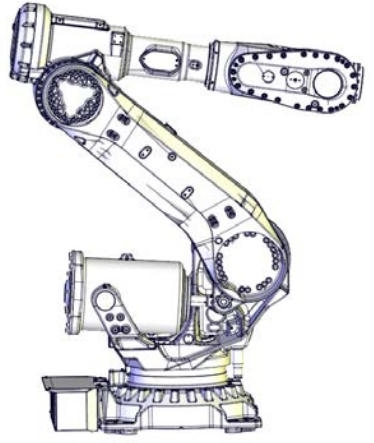

	Action	Note
8	<p><i>Foundry Plus.</i></p> <p>Cut the cable tie that hold the axis-1 and axis-2 motor cables on the protection plates.</p>	 <p>xx140000722</p>
9	<p><i>Foundry Plus.</i></p> <p>Disassemble the protection plates by removing five of the attachment screws (three M10x30 and two of the M5x12 screws).</p>	 <p>xx140000723</p>
10	<p><i>Foundry Plus.</i></p> <p>Remove the two protection plates.</p>	 <p>xx140000724</p>

Continues on next page

Robot position

	Action	Note
1	<p>Jog the robot into position:</p> <ul style="list-style-type: none"> • Axis 1: no significance (as long as the robot is secured to the foundation) • Axis 2: -45° • Axis 3: +65° • Axis 4: 0° • Axis 5: +80° • Axis 6: no significance 	 <p>xx1200001132</p>
2	<p> DANGER</p> <p>Turn off all:</p> <ul style="list-style-type: none"> • electric power supply • hydraulic pressure supply • air pressure supply <p>to the robot, before entering the robot working area.</p>	

Attaching the lifting accessories to the arm system

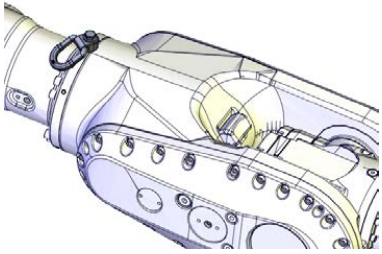
	Action	Note
1	<p> DANGER</p> <p>Make sure that all supplies for electrical power, hydraulic pressure, and air pressure are turned off.</p>	
2	<p> CAUTION</p> <p>The complete arm system weighs 1300 Kg. All lifting accessories used must be sized accordingly!</p>	
3	<p>Fit a lifting eye to the wrist.</p>	<p>Lifting eye: 3HAC16131-1</p> 

Continues on next page

4 Repair

4.8.2 Replacing the axis-1 gearbox (IRB 6700 - 300/2.70, IRB 6700 - 245/3.00)

Continued

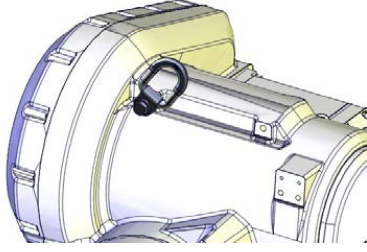
	Action	Note
4	Fit a lifting eye to the arm house, with a fender washer underneath. 	Lifting eye: 3HAC16131-1 Fender washer. Outer diameter: minimum 26 mm, maximum 30 mm, hole diameter: 13 mm, thickness: 3 mm. 

Attach the lifting chains

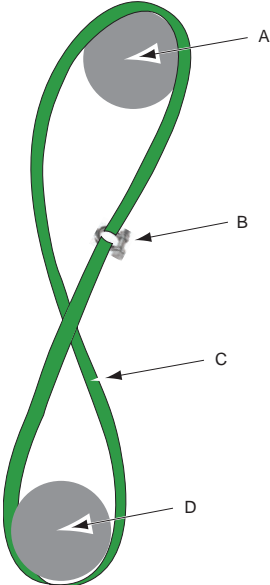
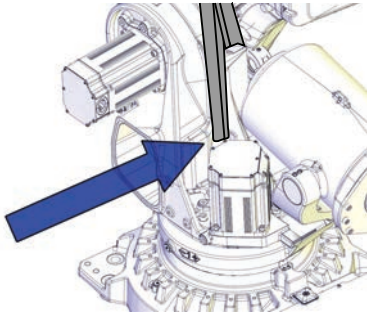

Use this procedure to attach the Lifting accessory (chain).

	Action	Note
1	Run a roundsling through the hole in the frame, continue up and over the upper arm.  Tip When attaching the roundsling, make sure to cross it over, creating a figure 8 of the roundsling. This will prevent the roundsling from gliding.  A Upper arm B Shackle C Roundsling D Hole in frame	Roundsling, 2.5 m: Length: 2.5 m. Lifting capacity: 2,000 kg. 

Continues on next page

4.8.2 Replacing the axis-1 gearbox (IRB 6700 - 300/2.70, IRB 6700 - 245/3.00)

Continued

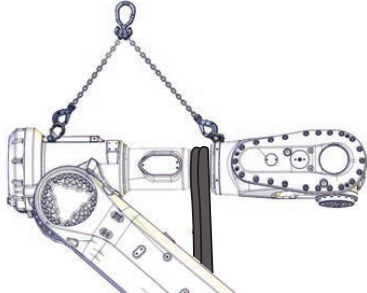
	Action	Note
2	Connect the roundsling with a shackle.	Lifting shackle SA-10-8-NA1  xx1400000729
3	Use caution and jog axis-3 slowly to stretch the roundsling.  Note Make sure the roundsling is stretched, so it can carry the weight of the frame.	
4	Attach the Lifting accessory (chain) to an overhead crane (or similar) and then to the lifting eye in the arm house and to the lifting eye in the wrist.	Lifting accessory (chain): 3HAC15556-1 

Continues on next page

4 Repair

4.8.2 Replacing the axis-1 gearbox (IRB 6700 - 300/2.70, IRB 6700 - 245/3.00)

Continued

Disconnecting the axis-1 motor cables

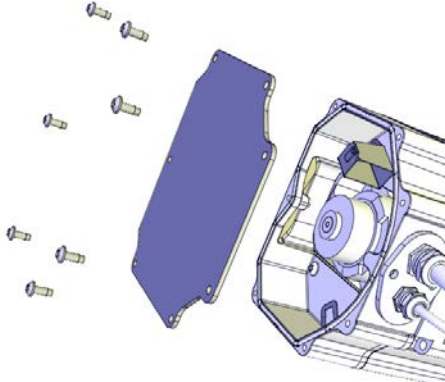
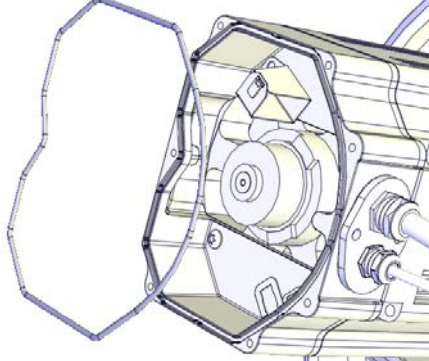
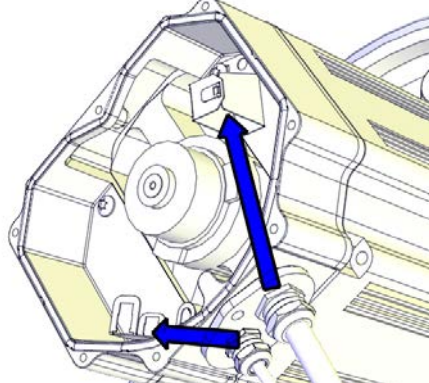
	Action	Note
1	 DANGER Make sure that all supplies for electrical power, hydraulic pressure, and air pressure are turned off.	
2	Unscrew the attachment screws and washers and remove the motor cover.	 xx1200001135
3	Make sure the o-ring is present.	 xx1200001070
4	Disconnect the motor cables.	 xx1200001066



Continues on next page

4.8.2 Replacing the axis-1 gearbox (IRB 6700 - 300/2.70, IRB 6700 - 245/3.00)

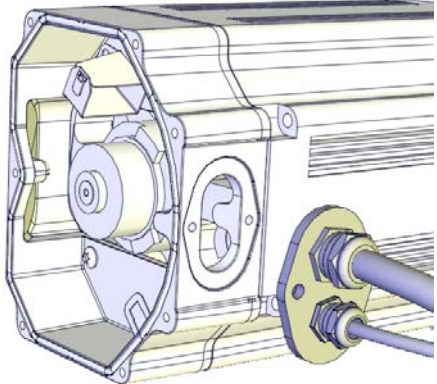
Continued

	Action	Note
5	<p>Remove the cable gland cover. Make sure the gasket is not damaged.</p> <p> Tip</p> <p>Make a note in which direction the cable gland hole is facing, if the motor will be removed too. The motor shall be refitted in the same position.</p>	 <p>xx1200001067</p>
6	Use caution and pull out the motor cables.	

Removing the axis-1 motor



	Action	Note
1	<p> DANGER</p> <p>Make sure that all supplies for electrical power, hydraulic pressure, and air pressure are turned off.</p>	
2	Attach the lifting accessories.	Lifting accessory (chain): 3HAC15556-1 Lifting accessory, motor: 3HAC14459-1.
3	<p>To release the brakes, connect the 24 VDC power supply. Connect to R2.MP1-connector:</p> <ul style="list-style-type: none"> • + = pin 2 • - = pin 5 	24 VDC power supply
4	<p> CAUTION</p> <p>The weight of the motor is 25 kg All lifting accessories used must be sized accordingly.</p>	

Continues on next page

4 Repair

4.8.2 Replacing the axis-1 gearbox (IRB 6700 - 300/2.70, IRB 6700 - 245/3.00)

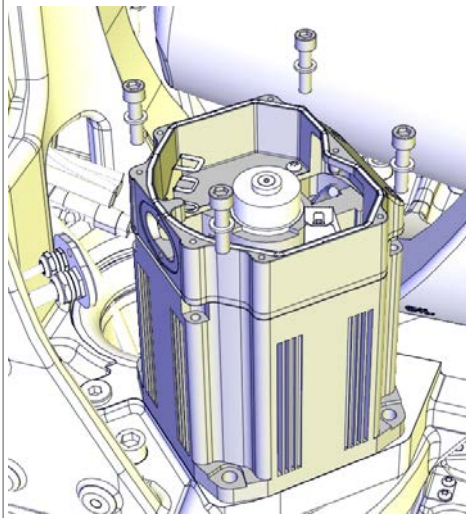
Continued

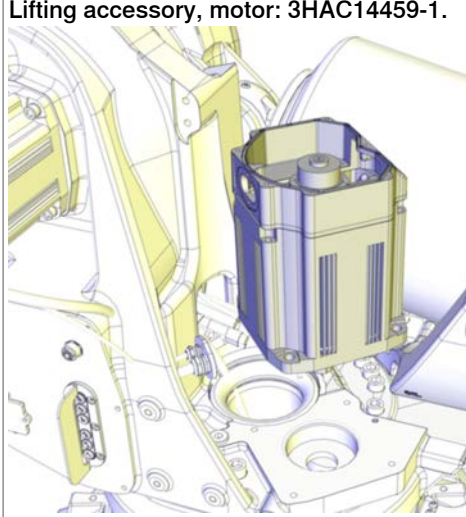
	Action	Note
5	<p>Unscrew the attachment screws and washers. Use a bits extender to reach the screws.</p>	<p>Bits extender: 3HAC12342-1</p>  <p>xx1200001071</p>
6	<p>Fit guide pins in opposite holes.</p>	<p>Guide pin, M10x150: 3HAC15521-2 Always use guide pins in pairs.</p>
7	<p> CAUTION Whenever parting/mating motor and gearbox, the gears may be damaged if excessive force is used.</p>	
8	<p>If needed, use removal tools to help remove the motor.</p>	<p>Removal tool kit M12 and M14: 3HAC057339-002 Required dimension of removal tool depends on motor type A or B, see Identifying the motor by article number on page 805 Used to push out the motor, if necessary. Always use removal tools in pairs.</p>
9	<p>Use caution and lift the motor straight up to get the pinion parted from the gear.</p>	<p>Lifting accessory (chain): 3HAC15556-1 Lifting accessory, motor: 3HAC14459-1.</p>  <p>xx1200001072</p>

Continues on next page

4.8.2 Replacing the axis-1 gearbox (IRB 6700 - 300/2.70, IRB 6700 - 245/3.00)

Continued

Action	Note
10 Disconnect the 24 VDC power supply.	

Preparations before removing the cable harness in the base

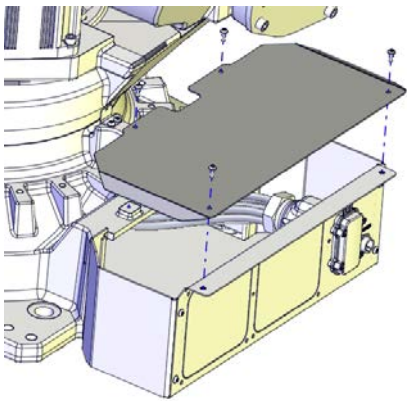
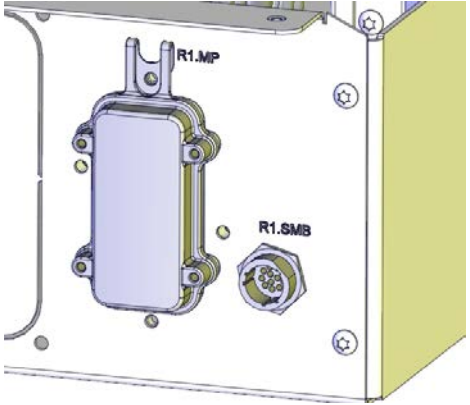
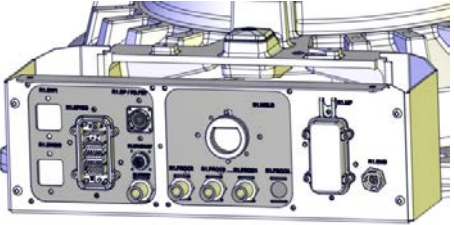

Action	Note
<p>1</p>  <p>DANGER</p> <p>Make sure that all supplies for electrical power, hydraulic pressure, and air pressure are turned off.</p>	
<p>2 Remove the base cover.</p>	 <p>xx130000561</p>
<p>3 Disconnect connectors:</p> <ul style="list-style-type: none"> • R1.MP • R1.SMB 	 <p>xx130000591</p>
<p>4 If used, disconnect the DressPack hoses in the base.</p>	 <p>xx140000366</p>

Continues on next page

4 Repair

4.8.2 Replacing the axis-1 gearbox (IRB 6700 - 300/2.70, IRB 6700 - 245/3.00)

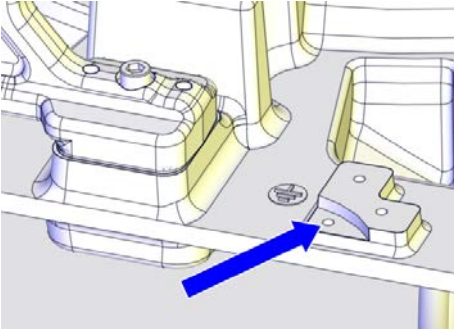
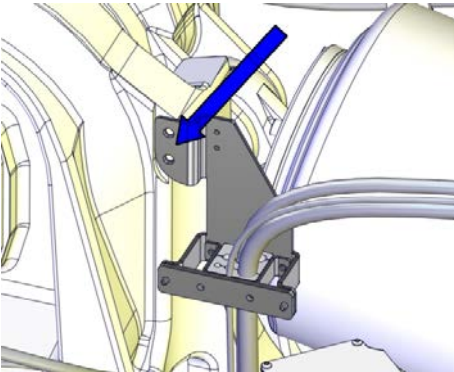
Continued

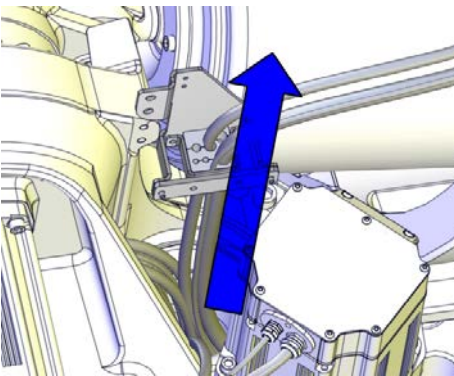
	Action	Note
5	Disconnect the earth cable.	<p>Screw dimension : M6x16 Washer dimension : 6.4x17x3</p>  <p>xx1400000354</p>
6	<p>If used, remove the attachment screws that secure the bracket. This is done to facilitate removal of the DressPack hoses.</p>	 <p>xx1400000078</p>
7	<p>If used, use caution and pull out the DressPack hoses through the protection tube in the base.</p> <p> Note</p> <p>There is no need to pull out the DressPack cables at this point!</p>	 <p>xx1400000088</p>

Removing the cable harness in the base

	Action	Note
1	If equipped with DressPack, pull out the DressPack cables through the protection tube and place them carefully over the balancing device.	

Continues on next page

4.8.2 Replacing the axis-1 gearbox (IRB 6700 - 300/2.70, IRB 6700 - 245/3.00)

Continued

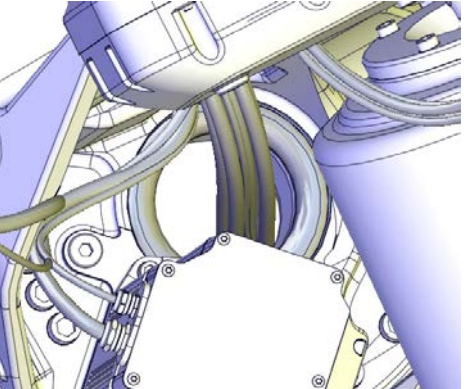
	Action	Note
2	Pull out the robot cable harness through the protection tube.	 <p>xx1300000732</p>
3	Place the cable harness over the balancing device.	

Lifting away the complete arm system

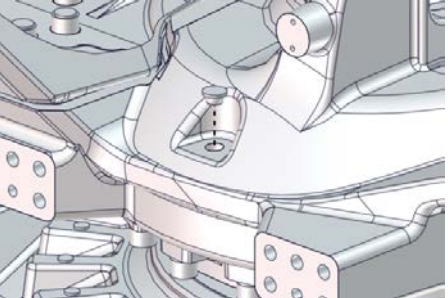
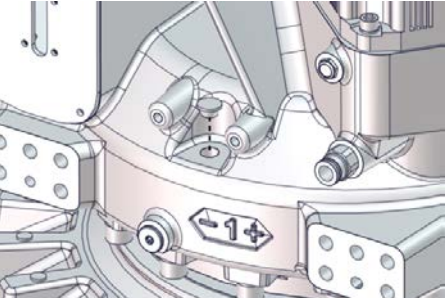





	Action	Note
1	Check that the axis-1 gearbox is drained and then remove the draining equipment.	
2	Raise the overhead crane to stretch all lifting accessories.	
3	<p>Remove the two protection plugs or M16 screws on the left and right hand side of the frame and install guide pins in the holes.</p> <p> Tip</p> <p>Lubricate the guide pins with some grease to make the frame slide better.</p>	 <p>xx1700000320</p>  <p>xx1700000321</p> <p>Guide pin, M16x120: 3HAC062397-001 Always use guide pins in pairs.</p>

Continues on next page

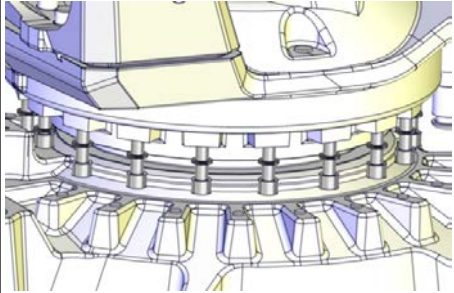
4 Repair





4.8.2 Replacing the axis-1 gearbox (IRB 6700 - 300/2.70, IRB 6700 - 245/3.00)

Continued

	Action	Note
4	<p>Unscrew the remaining attachment screws as far as it is possible at this point.</p>	 <p>xx1400002169</p> <p> Note</p> <p>It will not be possible to remove the screws completely at this point.</p>
5	<p> CAUTION</p> <p>The complete arm system weighs: 1300 Kg. All lifting accessories used must be sized accordingly.</p>	
6	<p>Lift away the complete arm system.</p> <p> CAUTION</p> <p>When the arm system has left the guide pins it can move. Use caution in order to avoid injury or damage!</p> <p> Note</p> <p>There will be some oil spill!</p>	
7	<p>Put down the arm system on the floor.</p>	
8	<p> DANGER</p> <p>When the complete arm system is removed and resting by itself on the floor, make sure it is resting completely stable before removing the lifting accessories. Do not change the position of the axes from the position described earlier.</p>	

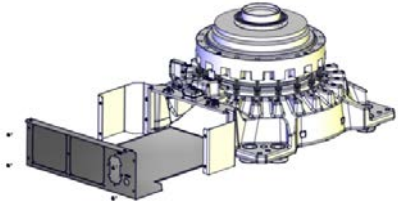
Continues on next page

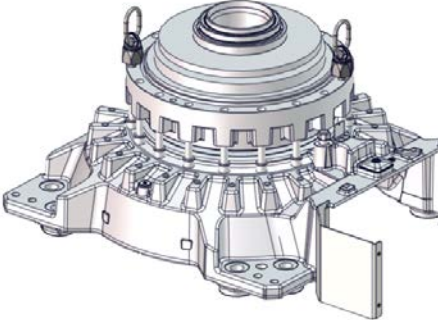
Removing the gearbox

	Action	Note
1	Remove the back plate.	 <p>xx1400002171</p>
2	Fit two lifting eyes in opposite holes in the gearbox.  CAUTION Leave a couple of millimeters of space between the lug and the surface of the gearbox. This is done in order not to damage the surface of the gearbox which is a sealing surface.	Lifting eye: 3HAC14457-4  <p>xx1700000323</p>
3	 CAUTION The weight of the gearbox and base together is 240 kg (IRB 6700 -235/2.65, -205/2.80, -175/3.05, -150/3.20, -200/2.60, -155/2.85) 305 kg (IRB 6700 -300/2.70, -245/3.00) All lifting accessories used must be sized accordingly.	

Continues on next page

4 Repair

4.8.2 Replacing the axis-1 gearbox (IRB 6700 - 300/2.70, IRB 6700 - 245/3.00)



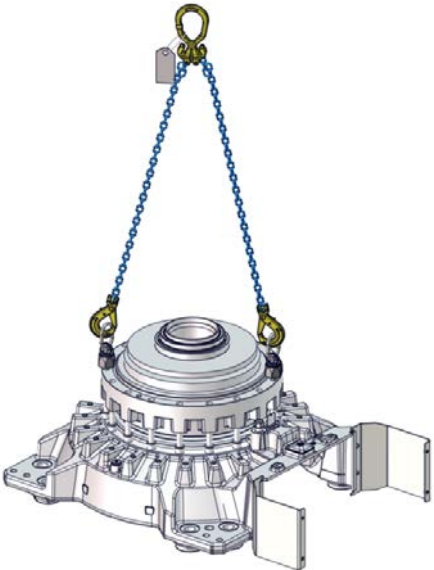
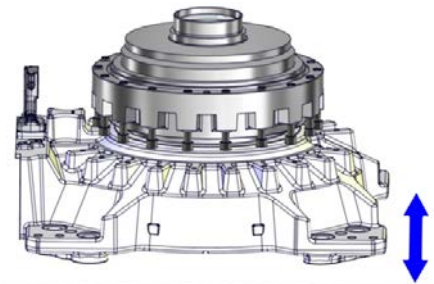
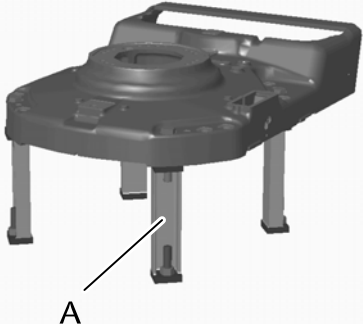

Continued

	Action	Note
4	Attach the lifting accessory.	Lifting accessory (chain): 3HAC15556-1  xx170000324
5	Unscrew the attachment screws that hold the base to the foundation and lift base and gearbox up high enough to be able to fit the four support legs.	 xx1400002180
6	Secure the support legs to the foundation using the same holes as to secure the base.	 xx100000364 A Support legs: 3HAC15535-1.
7	Lower the base and gearbox to the support legs and secure.	

Continues on next page

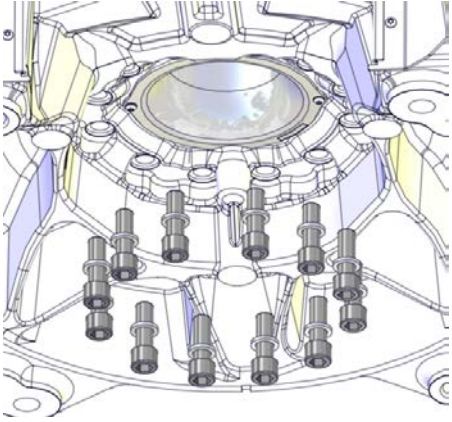
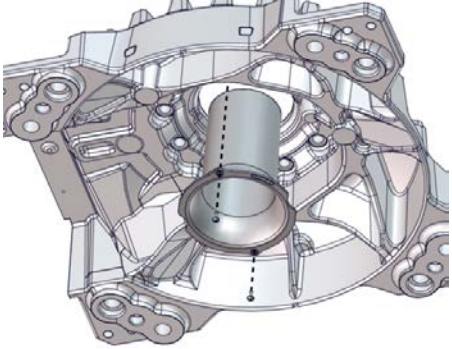
4.8.2 Replacing the axis-1 gearbox (IRB 6700 - 300/2.70, IRB 6700 - 245/3.00)

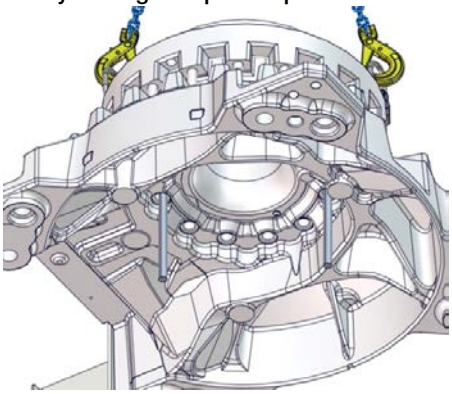
Continued

Action	Note
<p>8 With base and gearbox safely resting on the support legs, unscrew the attachment screws that secure the gearbox to the base, from underneath the base.</p> <p> Tip</p> <p>This procedure is best performed by two persons working together:</p> <ul style="list-style-type: none"> • one underneath the robot base making sure that the bit is being fitted into the screw head holes, all the way until they reach the bottom • one using the torque wrench, tightening the screws from beside the base. 	 <p>xx1400002172</p>
<p>9 Remove the protection tube from the base by removing the two attachment screws and pulling the tube downwards.</p>	 <p>xx1700001375</p>
<p>10 Fit two guide pins in opposite holes.</p> <p> Tip</p> <p>Lubricate the guide pins with some grease to make the gearbox slide better.</p>	<p>Guide pin, M20x180: 3HAC048814-002 Always use guide pins in pairs.</p>  <p>xx1700000337</p>
<p>11  CAUTION</p> <p>The weight of the gearbox is 92 kg (IRB 6700 -235/2.65, -205/2.80, -175/3.05, -150/3.20, -200/2.60, -155/2.85) 140 kg (IRB 6700 -300/2.70, -245/3.00) All lifting accessories used must be sized accordingly.</p>	

Continues on next page

4 Repair

4.8.2 Replacing the axis-1 gearbox (IRB 6700 - 300/2.70, IRB 6700 - 245/3.00)

Continued

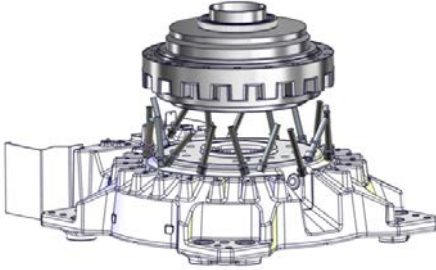
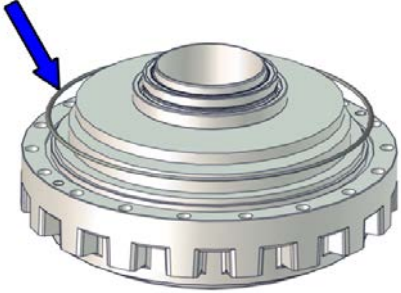
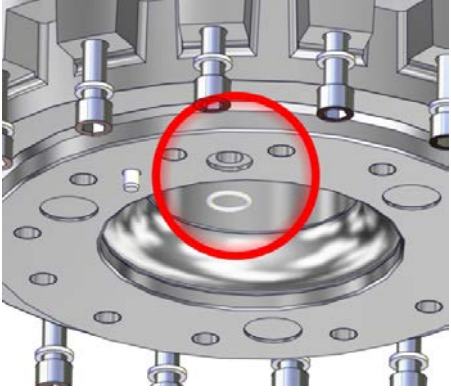



Action	Note
12 Lift away the gearbox.	 <p>xx170000566</p>
13 Remove the old o-ring to use it as aid in holding the screws during fitting of the new gearbox. A new o-ring must be installed to the new gearbox.	 <p>xx1700001378</p>
14 Make sure that the o-ring between base and gearbox is not lost.	 <p>xx1400002175</p>

Continues on next page

Refitting the axis-1 gearbox

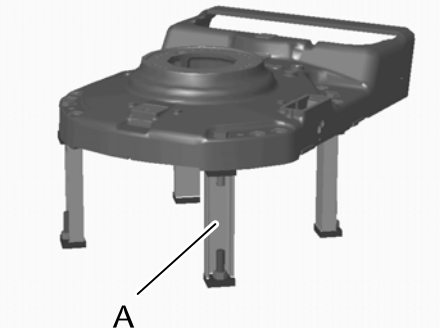
These procedures describe how to refit the axis-1 gearbox.

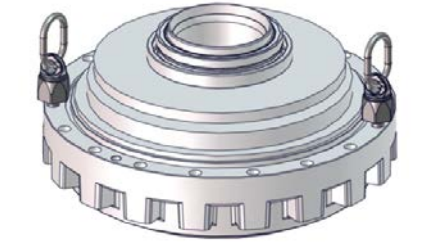
Preparations before refitting the axis-1 gearbox

	Action	Note
1	<p>If not already done, fit and secure the four support legs to the foundation. Then lift up and secure the base on top of the legs.</p>	 <p>xx100000364</p> <p>A Support legs: 3HAC15535-1.</p>
2	<p>Fit two lifting eyes in opposite holes in the gearbox.</p> <p> CAUTION</p> <p>Leave a couple of millimeters of space between the lug and the surface of the gearbox. This is done in order not to damage the surface of the gearbox which is a sealing surface.</p>	<p>Lifting eye: 3HAC14457-4</p>  <p>xx170000325</p>
3	<p> CAUTION</p> <p>The weight of the gearbox is</p> <p>92 kg (IRB 6700 -235/2.65, -205/2.80, -175/3.05, -150/3.20, -200/2.60, -155/2.85)</p> <p>140 kg (IRB 6700 -300/2.70, -245/3.00)</p> <p>All lifting accessories used must be sized accordingly.</p>	

Continues on next page

4 Repair

4.8.2 Replacing the axis-1 gearbox (IRB 6700 - 300/2.70, IRB 6700 - 245/3.00)

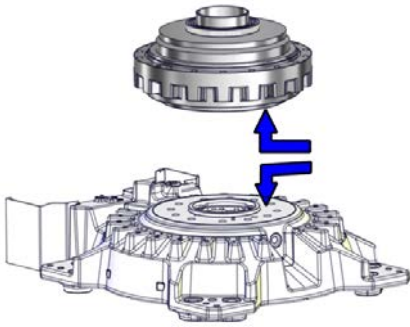
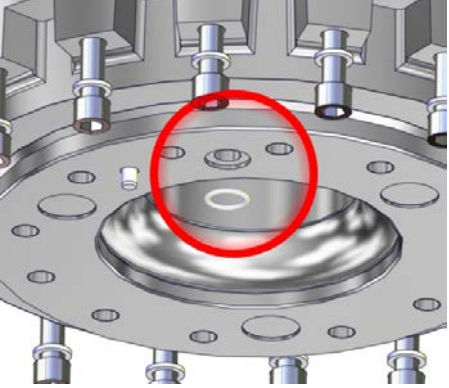

Continued

	Action	Note
4	Attach the lifting accessory and lift the gearbox.	Lifting accessory (chain): 3HAC15556-1  <small>xx170000326</small>
5	Wipe the contact surfaces between gearbox and base clean from any contamination.	 <small>xx170000567</small>
6	Wipe clean the o-ring groove for the small o-ring beneath the gearbox.	 <small>xx1400002175</small>
7	Replace the small o-ring between base and gearbox with a new. Clean the new o-ring, put some grease on it and place it in the groove.	O-ring: 3HAB3772-97.

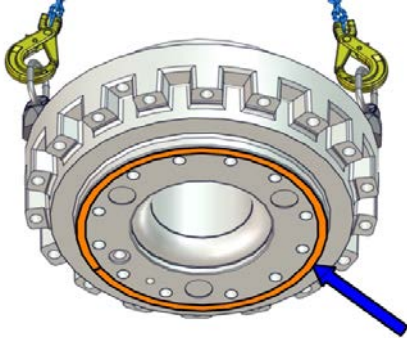

Continues on next page

4.8.2 Replacing the axis-1 gearbox (IRB 6700 - 300/2.70, IRB 6700 - 245/3.00)

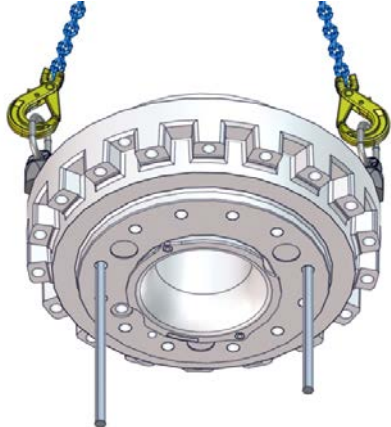
Continued

Action	Note
<p>8 Apply flange sealant to the mounting interface on the gearbox.</p>	<p>Flange sealant: Loctite 574 (-).</p>  <p>xx1700001384</p>
<p>9 Fit guide pins in opposite holes in the gearbox.</p> <p> Tip</p> <p>Lubricate the guide pins with some grease to make the gearbox slide better.</p>	<p>Guide pin, M20x180: 3HAC048814-002 Always use guide pins in pairs.</p>  <p>xx1700000327</p>

Refitting the gearbox to the base



Action	Note
<p>1 Before the gearbox is being fitted, place the attachment screws that will secure the gearbox to the frame, temporarily in their holes and lock screws with the old o-ring. This is done to prevent the screws from falling out.</p> <p> Note</p> <p>Do not use the new o-ring!</p>	<p>If the attachment screws are not fitted like this at this point, it will be almost impossible to fit the screws later when the gearbox is resting on the base.</p>  <p>xx1400002176</p>

Continues on next page

4 Repair

4.8.2 Replacing the axis-1 gearbox (IRB 6700 - 300/2.70, IRB 6700 - 245/3.00)

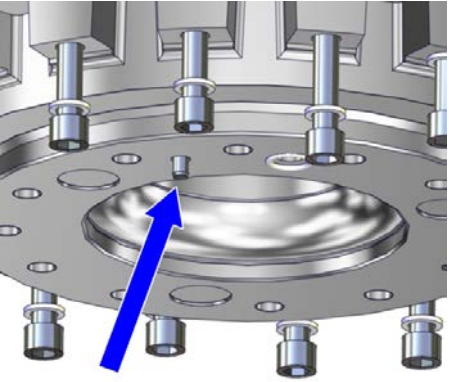

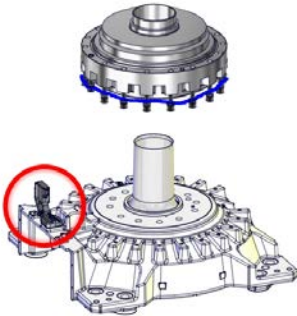
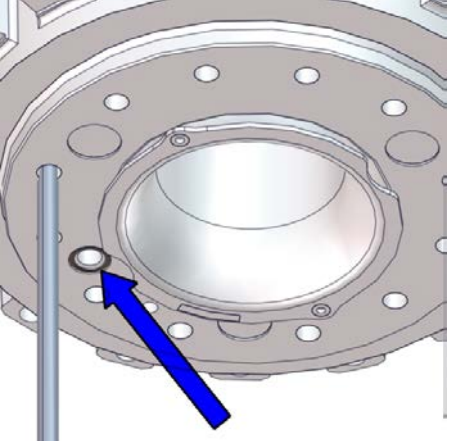
Continued

	Action	Note
2	<p>Make sure that the locating pin in the base will match its hole in the gearbox.</p>	 <p>xx1400002177</p>
3	<p>With all screws in position, lower the gearbox carefully down against the base with guidance from the guide pins.</p> <p> Note</p> <p>Make sure that the small o-ring underneath the gearbox, stays fitted correctly when the gearbox is being fitted.</p> <p> Note</p> <p>Be careful not to collide with the calibration bracket at the base.</p>  <p>xx1400002178</p>	 <p>xx1700000328</p> <p>O-ring: 3HAB3772-97.</p>
4	<p>Lower the lifting accessory so that the chain is no longer stretched.</p>	

Continues on next page

4.8.2 Replacing the axis-1 gearbox (IRB 6700 - 300/2.70, IRB 6700 - 245/3.00)

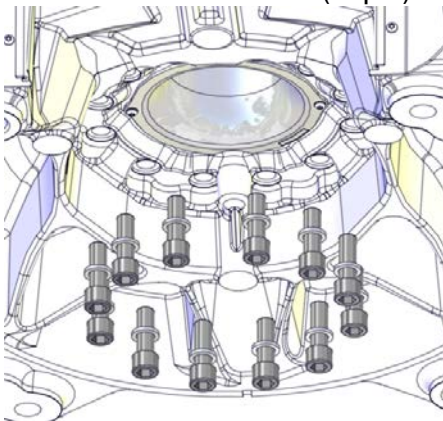
Continued

	Action	Note
5	Fit the attachment screws that secure the gearbox to the base, from underneath.	<p>Attachment screws: M20x60 (12 pcs)</p>  <p>xx1400002172</p>
6	Remove the guide pins and fit the two remaining screws.	
7	<p>Secure the attachment screws.</p> <p> Tip</p> <p>This procedure is best performed by two persons working together:</p> <ul style="list-style-type: none"> • one underneath the robot base making sure that the bit is being fitted into the screw head holes, all the way until they reach the bottom • one using the torque wrench, tightening the screws from beside the base. 	Tightening torque: 500 Nm.
8	<p>Check the protection tube for damages. Especially inspect the surface for the sealing ring. Replace if damaged.</p>	 <p>xx1700001374</p>
9	Wipe the surfaces of the protection tube and the hole in axis-1 gearbox clean from any contamination.	
10	Put some grease on the protection tube.	

Continues on next page

4 Repair

4.8.2 Replacing the axis-1 gearbox (IRB 6700 - 300/2.70, IRB 6700 - 245/3.00)

Continued

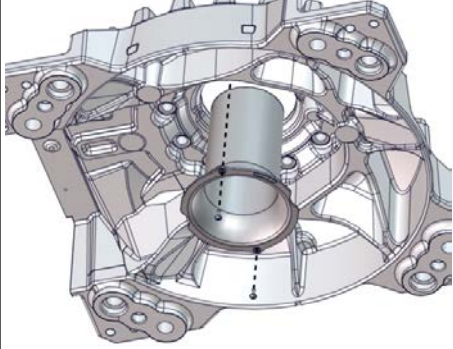

	Action	Note
11	Refit the protection tube to the base. Secure with the two attachment screws. Apply locking liquid on the screws.	Screws: M6x16 (2 pcs). Tightening torque: 10 Nm. Locking liquid: Loctite 243 (3HAB7116-1).  xx1700001375

Refitting the base to the foundation

	Action	Note
1	 CAUTION The weight of the gearbox and base together is 240 kg (IRB 6700 -235/2.65, -205/2.80, -175/3.05, -150/3.20, -200/2.60, -155/2.85) 305 kg (IRB 6700 -300/2.70, -245/3.00) All lifting accessories used must be sized accordingly.	
2	Stretch the lifting accessories to take the weight of base and gearbox.	
3	Unscrew the screws that secure the base to the support legs and lift up base and gearbox.	
4	Remove the support legs.	
5	Lower the base and gearbox to the foundation.	
6	Secure the base to the foundation.	M24 x 100 (installation on base plate/foundation) (8 pcs) 550 Nm (screws lubricated with Molykote 1000) 600-725 Nm, typical 650 Nm (screws none or lightly lubricated)

Continues on next page

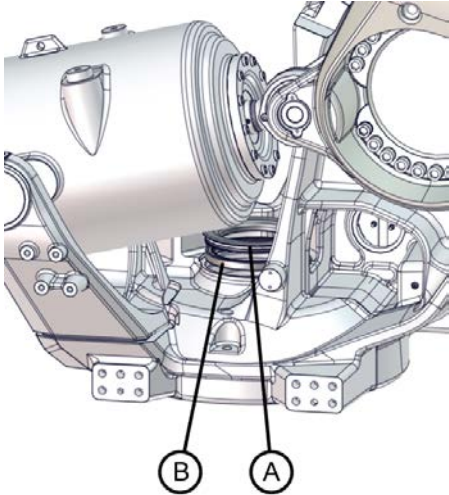
Preparations before refitting the arm system

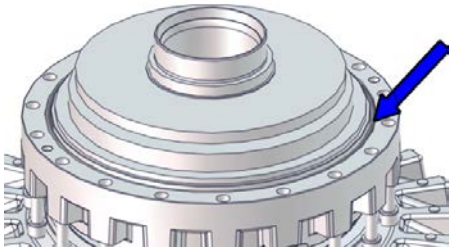

	Action	Note
1	Remove the sealing ring and the radial sealing from the frame.	 <p>xx170000569</p> <p>A Sealing ring B Radial sealing with dust lip</p>
2	Remove old residues of flange sealant and other contamination from the contact surfaces on the gearbox.	
3	Wipe clean the contact surfaces from any remaining contamination.	
4	Wipe clean the o-ring groove in the gearbox and apply some grease to the groove.	Grease, Shell Gadus S2: 3HAC042536-001.
5	<p>Wipe a new o-ring clean, apply some grease to it and replace the old one between base and frame with a new.</p> <p>Install the new o-ring in the groove.</p> <p> Note</p> <p>A new o-ring also needs to be cleaned!</p>	<p>O-ring: 3HAB3772-160. Grease, Shell Gadus S2: 3HAC042536-001.</p>  <p>xx170000336</p>

Continues on next page

4 Repair

4.8.2 Replacing the axis-1 gearbox (IRB 6700 - 300/2.70, IRB 6700 - 245/3.00)

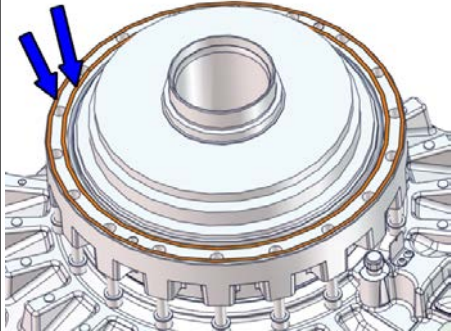

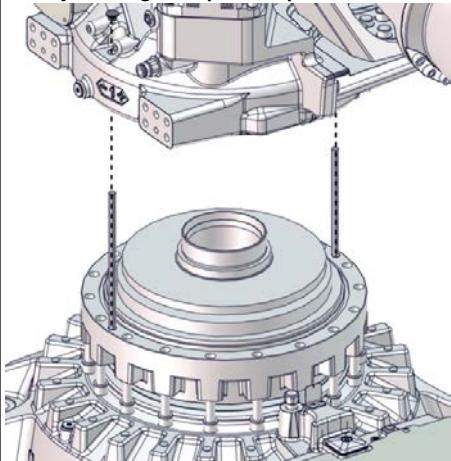
Continued

	Action	Note
6	Apply flange sealant in two strings according to the figure.	Flange sealant, Loctite 574: -.  <small>xx1700000415</small>
7	Apply some grease on: <ul style="list-style-type: none"> • the outside of the bearing • the guiding part of the bearing • the edge of the protection tube • the edge around the gearbox. 	
8	Apply guide pins in the guide pin holes in the gearbox.  Tip Lubricate the guide pins with some grease to make the frame slide better.	Guide pin, M16x120: 3HAC062397-001 (2 pcs). Always use guide pins in pairs.  <small>xx1700000329</small>

Refitting the arm system

	Action	Note
1	 CAUTION The arm system weighs 1300 Kg. All lifting accessories used must be sized accordingly!	
2	Make sure that all lifting accessories still is fitted correctly on the arm system.	See Attachment points of lifting accessory on page 200 .

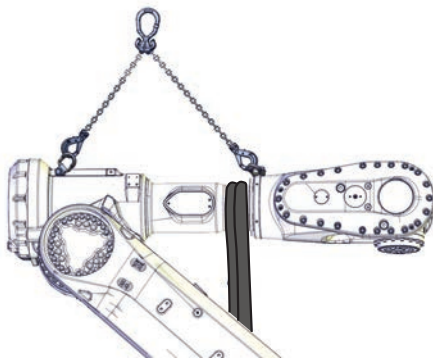
Continues on next page



	Action	Note
3	<p>Attach the upper arm lifting accessory (chain) to an overhead crane (or similar) and then to the lifting eye in the arm house and to the lifting eye in the wrist.</p>	<p>Lifting accessory (chain): 3HAC15556-1</p>  <p>xx1400002108</p>
4	<p>Lift the arm system up, to be able to reach the contact surfaces underneath the frame.</p>	
5	<p>Wipe clean the contact surfaces from any remaining contamination.</p>	
6	<p>Before putting the complete arm system on to the guide pins, make sure that the hole pattern will match and that the guide pins will enter the correct holes in the frame.</p>	
7	<p>Remove the big o-ring that holds the attachment screws in the temporary position and let them drop down on the base.</p> <p> Note</p> <p>Make sure that none of the screws are missing or in the wrong position.</p>	
8	<p>Lift the complete arm system and lower it slowly down over the guide pins, until it is possible to insert the attachment screws manually.</p> <p> CAUTION</p> <p>Do not lower the arm system completely at this stage! The attachment screws must be fitted in two steps. If not, the complete arm system will risk resting on the attachment screws in the wrong position!</p>	
9	<p>Fit the attachment screws manually as far as possible. Lower the complete arm system slowly in steps, until all attachment screws no longer can reach the base, when the arm system is lowered all the way down.</p>	<p>Attachment screws: M16x110</p>
10	<p>Make sure that the complete arm system is lowered all the way down.</p>	

Continues on next page

4 Repair

4.8.2 Replacing the axis-1 gearbox (IRB 6700 - 300/2.70, IRB 6700 - 245/3.00)

Continued

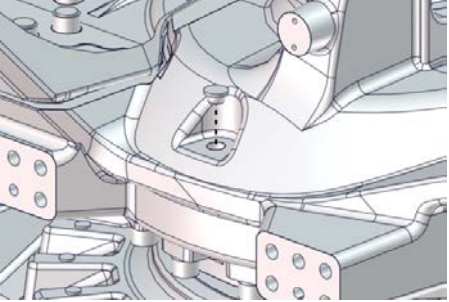
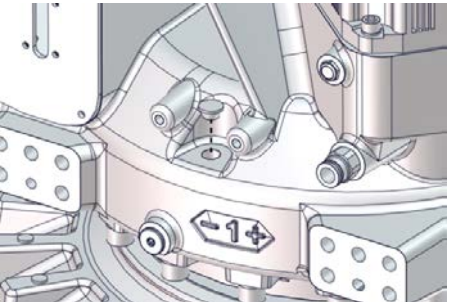
	Action	Note
11	 Note The attachment screw at the axis-1 synchronization plate can not be reached to be secured at this stage. Make sure it is still in its place and will not be damaged in the continued procedure.	
12	Secure all screws now possible to reach.  Note A bits holder is needed to be able to reach the attachment screws.	Bit holder: 3HAC029090-001. Tightening torque: 300 Nm
13	Manually rotate axis-1 to a position where the remaining attachment screw can be secured.	
14	Remove the guide pins and refit the two plastic protection plugs or the two M16 screws.	 xx170000320  xx170000321

Continues on next page

4.8.2 Replacing the axis-1 gearbox (IRB 6700 - 300/2.70, IRB 6700 - 245/3.00)

Continued

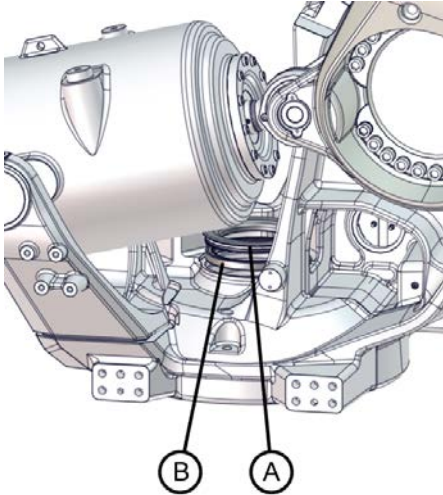
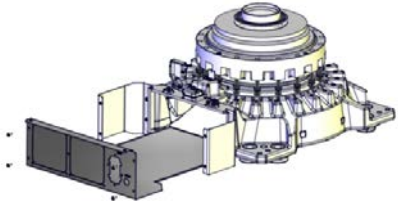
	Action	Note
15	Refit the radial sealing. Replace if damaged.	 <p style="text-align: center;">xx170000569</p> <p>A Sealing ring B Radial sealing with dust lip</p>
16	Refit the sealing ring. Make sure the o-ring is placed in its groove on the sealing ring. Replace if damaged.	
17	Refit the back plate.	 <p style="text-align: center;">xx1400002171</p>

Securing the axis-1 motor

	Action	Note
1	Fit guide pins in opposite holes.	Guide pin, M10x150: 3HAC15521-2 Always use guide pins in pairs.
2	 CAUTION The motor weighs 25 kg. All lifting accessories used must be sized accordingly.	
3	Apply the lifting accessory.	Lifting accessory, motor: 3HAC14459-1.
4	Fit the rotation tool.	Rotation tool: 3HAB7887-1
5	Connect the 24 VDC power supply to release the brakes. To release the brakes, connect the 24 VDC power supply as described in the list. Connect to R2.MP1-connector: <ul style="list-style-type: none"> • + = pin 2 • - = pin 5 	

Continues on next page

4 Repair

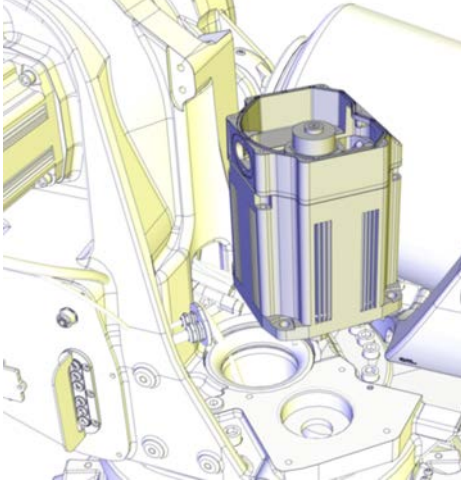
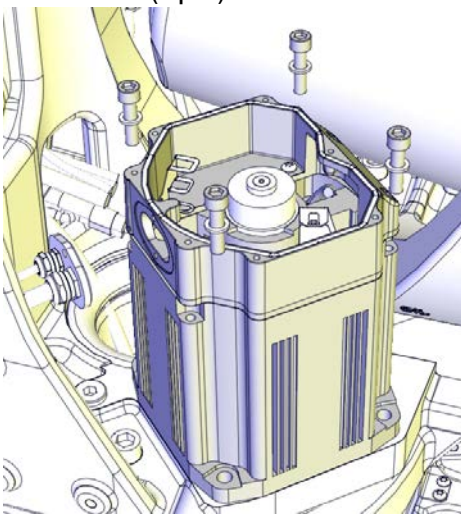

4.8.2 Replacing the axis-1 gearbox (IRB 6700 - 300/2.70, IRB 6700 - 245/3.00)

Continued

	Action	Note
6	<p> CAUTION</p> <p>Whenever parting/mating motor and gearbox, the gears may be damaged if excessive force is used.</p>	
7	<p>Lower the motor into position.</p> <ul style="list-style-type: none"> • Make sure that the motor pinion is properly mated to the gear in the gearbox. • Make sure that the motor pinion does not get damaged. • Make sure that the direction of the cable gland exit is facing the correct way. 	<p>Lifting accessory (chain): 3HAC15556-1 Lifting accessory, motor: 3HAC14459-1.</p>  <p>xx1200001072</p>
8	<p>Secure the motor with its attachment screws and washers. Use a bits extender to reach the screws.</p>	<p>Bits extender: 3HAC12342-1 Tightening torque: 50 Nm. Screws: M10x30 Steel 12.9 Gle 603+Geo500 (4 pcs)</p>  <p>xx1200001071</p>
9	<p>Perform a leak-down test (if not already done).</p>	<p>See Performing a leak-down test on page 186.</p>
10	<p>Disconnect the 24 VDC power supply.</p>	

Continues on next page

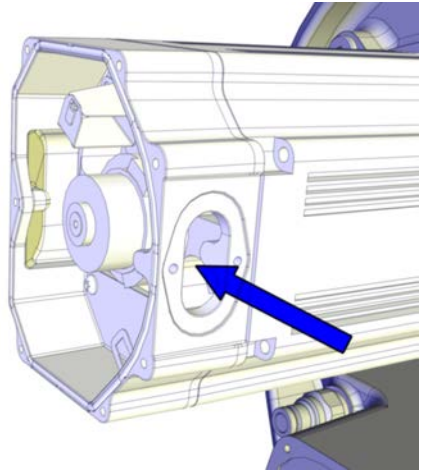
Connecting the axis-1 motor cables

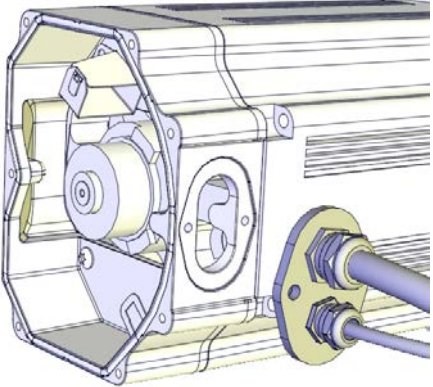
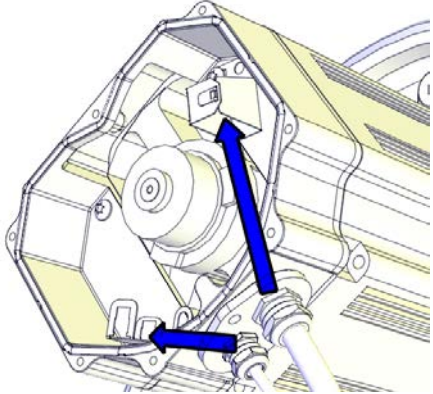

	Action	Note
1	Push the motor cables through the cable gland opening.	 <p>xx130000738</p>
2	Refit the cable gland cover.  Note Replace the gasket if damaged.	 <p>xx1200001067</p>
3	Connect the motor cables. Connect in accordance with the markings on the connectors.	 <p>xx1200001066</p>

Continues on next page

4 Repair

4.8.2 Replacing the axis-1 gearbox (IRB 6700 - 300/2.70, IRB 6700 - 245/3.00)

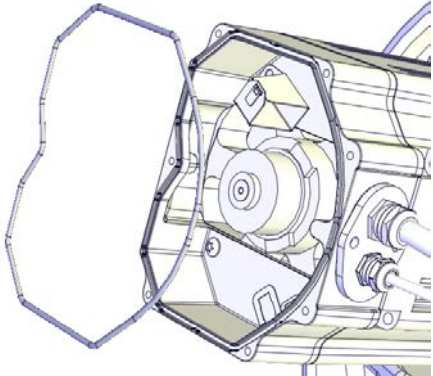

Continued

	Action	Note
4	<p>Inspect the o-ring.</p> <p> Note</p> <p>Replace if damaged.</p>	<p>O-ring, axis-1: 3HAB3772-111 (circular profile) / 3HAC054692-002 (hexagon profile)</p> <p>O-ring, axis-2: 3HAB3772-111 (circular profile) / 3HAC054692-002 (hexagon profile)</p> <p>O-ring, axis-3: 3HAB3772-111 (circular profile) / 3HAC054692-002 (hexagon profile)</p> <p>O-ring, axis-4: 3HAB3772-110 (circular profile) / 3HAC054692-001 (hexagon profile)</p>  <p>xx1200001070</p>
5	Wipe clean o-ring and o-ring groove.	
6	<p>Refit the o-ring.</p> <p> Tip</p> <p>Lubricate the o-ring with some grease for a better fitting in the groove.</p>	
7	<p> CAUTION</p> <p>When fitting the motor cover, make sure that none of the cables inside will be damaged.</p>	

Continues on next page

4.8.2 Replacing the axis-1 gearbox (IRB 6700 - 300/2.70, IRB 6700 - 245/3.00)

Continued

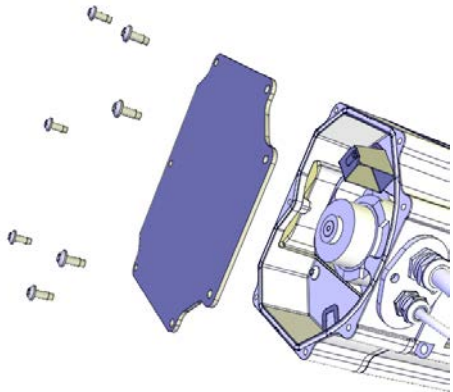
	Action	Note
8	<p>Refit the motor cover with it's attachment screws.</p> <p> Note</p> <p>Do not reuse the self-threading attachment screws. Replace with standard attachment screws or the threads will be damaged.</p> <p> Note</p> <p>Make sure the o-ring is undamaged and properly fitted.</p>	<p>Attachment screws: M5x12 8.8 (7 pcs)</p>  <p>xx1200001135</p>
9	<p>Make sure that the covers are tightly sealed.</p>	

Refilling oil in the gearbox

	Action	Note
1	<p>Refill oil in the gearbox.</p>	<p>See Changing oil, axis-1 gearbox on page 147.</p>

Refitting the cable harness in the base

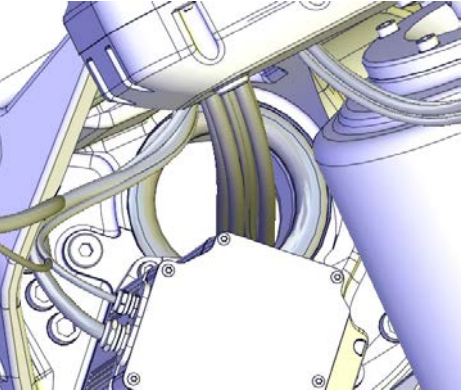
	Action	Note
1	<p>Run the cables through the protection tube in this order:</p> <ul style="list-style-type: none"> • R1.MP • R1.SMB <p>If necessary, lubricate the cables with grease to make them run more smoothly.</p>	 <p>xx1300000732</p>

Continues on next page

4 Repair

4.8.2 Replacing the axis-1 gearbox (IRB 6700 - 300/2.70, IRB 6700 - 245/3.00)

Continued

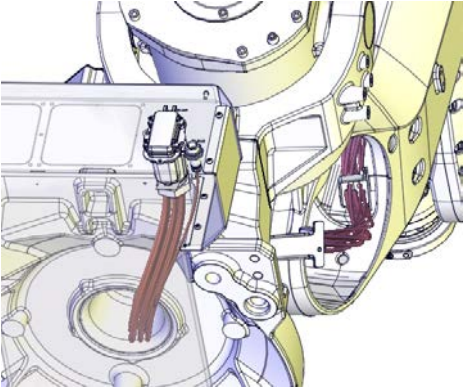
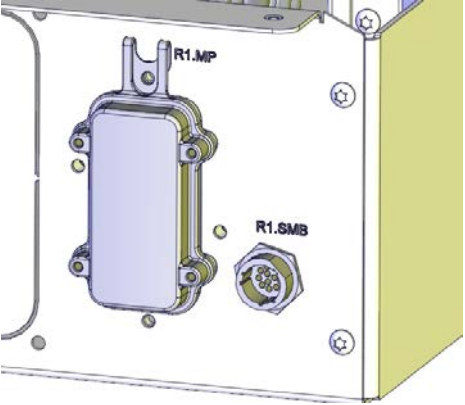
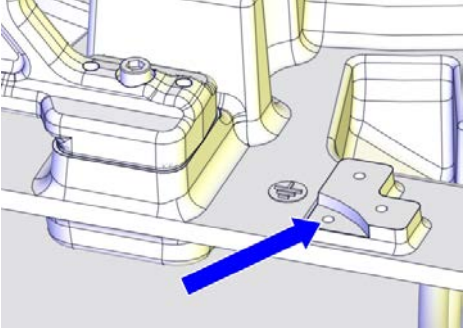
	Action	Note
2	<ul style="list-style-type: none"> Make sure that the cables are not twisted. Each cable must be in line with its position on the base plate. Make sure that the R1.SMB cable will run on the correct side of the R1.MP1, see the figure. 	 <p>xx1300000736</p>
3	Make sure that the markings on the cables are facing the base cover, when connected.	
4	Connect connectors R1.MP and R1.SMB.	<p>Tightening torque for R1.SMB: 10 Nm.</p>  <p>xx1300000591</p>
5	Connect the earth cable.	<p>Screw dimension: M6x16. Washer dimension: 6.4x17x3.</p>  <p>xx1400000354</p>
6	If used, run the DressPack cables through the protection tube in the base.	
7	<p>If used, run the DressPack hoses through the protection tube in the base.</p> <p>Make sure that the hoses are running correctly and are not twisted!</p>	

Continues on next page

4.8.2 Replacing the axis-1 gearbox (IRB 6700 - 300/2.70, IRB 6700 - 245/3.00)

Continued

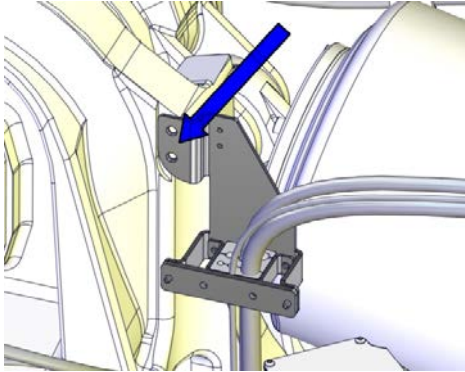
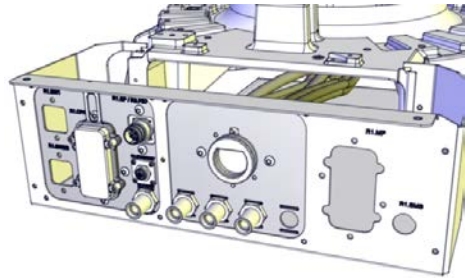
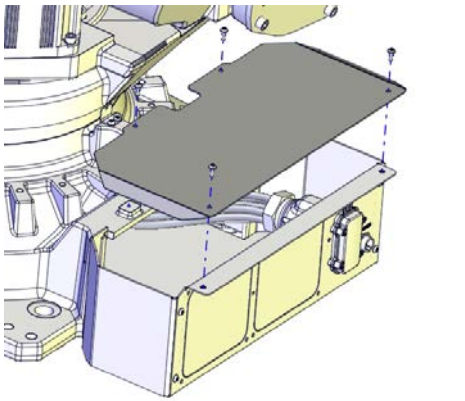
	Action	Note
8	If used, fit the bracket that hold the DressPack to the frame.	 <p>xx140000078</p>
9	If used, connect the DressPack cable package on the base plate.	 <p>xx120000052</p>
10	Refit the base cover.	 <p>xx1300000561</p>

Refitting the mechanical stop and remaining cable brackets

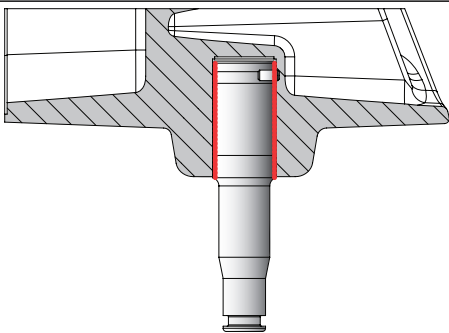
	Action	Note
1	<p><i>Foundry Plus:</i> Apply Mercasol on the surfaces shown in the figure, on stop pin and in the hole as shown in the figure.</p>	 <p>xx1400000378</p>

Continues on next page

4 Repair

4.8.2 Replacing the axis-1 gearbox (IRB 6700 - 300/2.70, IRB 6700 - 245/3.00)

Continued

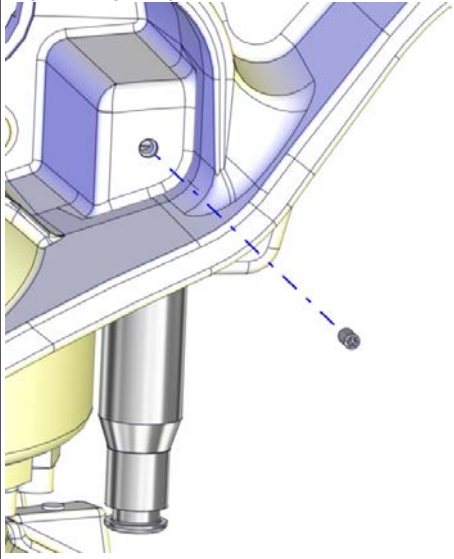
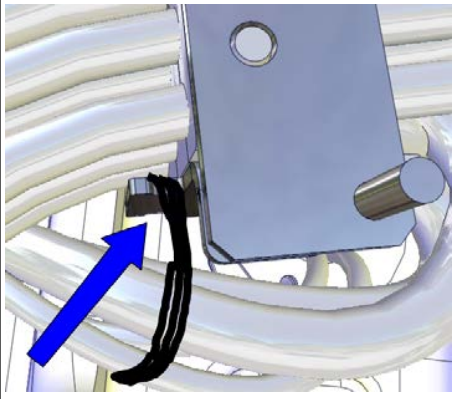
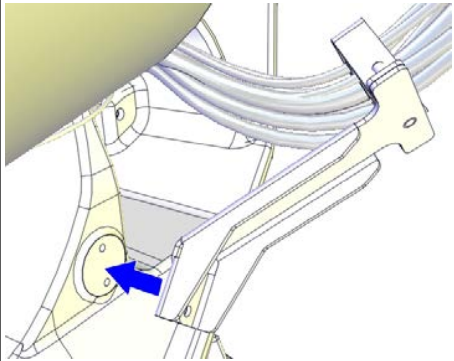
	Action	Note
2	Refit the mechanical stop pin and secure it with the attachment screw. Locking liquid (Loctite 243) on screw.	Tightening torque: 24 Nm  xx1400002179
3	Secure the cable harness inside the frame hole with a cable strap.	 xx1200001237
4	Refit the cable bracket on the frame.	 xx1200001246

Continues on next page

Concluding procedure

	Action	Note
1	Re-calibrate the robot.	Pendulum Calibration is described in <i>Operating manual - Calibration Pendulum</i> , enclosed with the calibration tools. Axis Calibration is described in Calibrating with Axis Calibration method on page 781 . General calibration information is included in section Calibration on page 767 .
2	 DANGER Make sure all safety requirements are met when performing the first test run.	

4 Repair

4.8.3 Replacing the axis-2 gearbox (IRB 6700 - 235/2.65, IRB 6700 - 205/2.80, IRB 6700 - 175/3.05, IRB 6700 - 150/3.20, IRB 6700 - 200/2.60, IRB 6700 - 155/2.85)

4.8.3 Replacing the axis-2 gearbox (IRB 6700 - 235/2.65, IRB 6700 - 205/2.80, IRB 6700 - 175/3.05, IRB 6700 - 150/3.20, IRB 6700 - 200/2.60, IRB 6700 - 155/2.85)

Validity of this section



Note

This section describes how to replace the gearbox on variants IRB 6700 - 235/2.65, IRB 6700 - 205/2.80, IRB 6700 - 175/3.05, IRB 6700 - 150/3.20, IRB 6700 - 200/2.60, IRB 6700 - 155/2.85.

How to replace the gearbox on variants IRB 6700 - 300/2.70, IRB 6700 - 245/3.00 see [Replacing the axis-2 gearbox \(IRB 6700 - 300/2.70, IRB 6700 - 245/3.00\) on page 680](#).

Space required beside

This section describes how to replace the gearbox without needing to remove the cable harness and DressPack cable package (if installed) from the robot.

The described procedure requires free space on the floor, in front of the frame (with axis-1 in calibration position). There should be enough space to place two pallets as shown in the figures in the procedures below.



DANGER

The base shall be fitted to the foundation when performing this procedure! Valid in both examples described below.

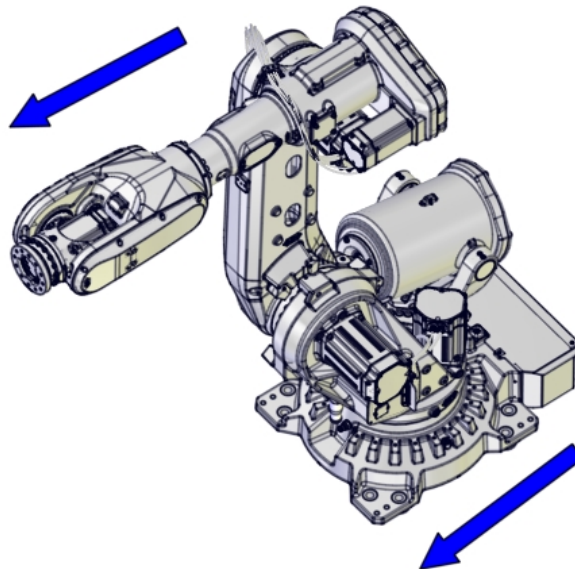

xx1300002303

Example 1: Position with space for pallets in front of the robot. Axis-1 in calibration position.

Continues on next page

4.8.3 Replacing the axis-2 gearbox (IRB 6700 - 235/2.65, IRB 6700 - 205/2.80, IRB 6700 - 175/3.05, IRB 6700 - 150/3.20, IRB 6700 - 200/2.60, IRB 6700 - 155/2.85)

Continued

If needed, run axis-1 into a position that gives the required space. The figure shows an example.

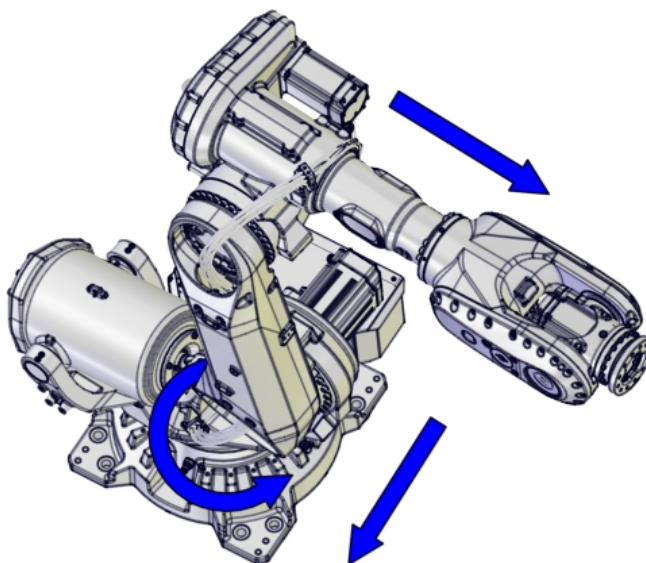

xx1300002304

Example 2: Axis-1 jogged to a position where it is possible to find the required space in another position of axis-1 than calibration position.



Note

Using this method to replace the gearbox with cable harness and DressPack fitted, is only a recommendation. If it is not possible to put the arm system close enough to the robot and keep the cable harness partly fitted, it may be necessary to remove the cable harness and DressPack in base and frame first.

Continues on next page

4 Repair

4.8.3 Replacing the axis-2 gearbox (IRB 6700 - 235/2.65, IRB 6700 - 205/2.80, IRB 6700 - 175/3.05, IRB 6700 - 150/3.20, IRB 6700 - 200/2.60, IRB 6700 - 155/2.85)

Continued

Location of the axis-2 gearbox

The axis-2 gearbox is located as shown in the figure.

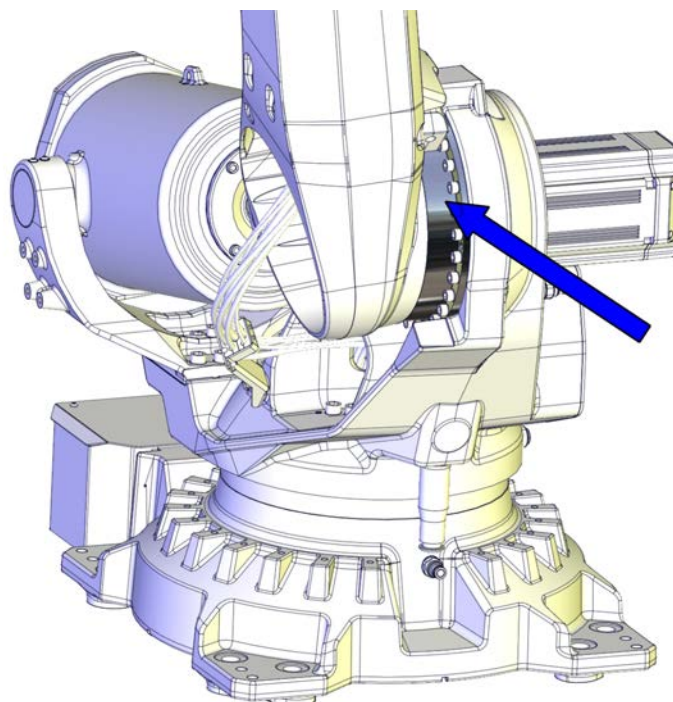

xx1200001276

Spare parts

Spare parts	Article number	Note
Axis-2 gearbox	See <i>Product manual, spare parts - IRB 6700/IRB 6700Inv.</i> <i>Product manual, spare parts - IRB 6790</i>	

Consumables

Equipment, etc	Article number	Note
Grease	3HAC042536-001	Shell Gadus S2 Used to lubricate o-rings.
O-ring	3HAB3772-107	D=102x3 Used on motor flange.
O-ring ⁱ	3HAB3772-111 (circular profile) / 3HAC054692-002 (hexagon profile)	D=169.5x3 Used on motor cover.
O-ring	3HAB3772-144 (D=309.3x3.1) / 3HAB3772-48 (D=319.3x5.7)	Located between the gearbox and the frame. Size depends on gearbox model. Measure the groove to see dimension of the o-ring.
VK cover	3HAA2166-28	VK 28x7
Locking liquid (Loctite 2701)	-	

Continues on next page

4.8.3 Replacing the axis-2 gearbox (IRB 6700 - 235/2.65, IRB 6700 - 205/2.80, IRB 6700 - 175/3.05, IRB 6700 - 150/3.20, IRB 6700 - 200/2.60, IRB 6700 - 155/2.85)

Continued

Equipment, etc	Article number	Note
Rust preventive	3HAC034903-001	Mercasol 3110 Waxcoat. Recommended drying time is 24h.

ⁱ The cross-section profile is either circular or hexagon. If only ordering the o-ring, order the same profile that is currently installed in the connection box.

Required tools and equipment

Equipment, etc.	Article number	Note
Oil collecting vessel	-	The capacity of the vessel must be sufficient to take the complete amount of oil.
Oil dispenser	-	One example of oil dispenser can be found in section Type of lubrication in gearboxes on page 145 .
Lifting eye	3HAC16131-1	M12
Lifting eye	3HAC14457-4	M16
Fender washer	-	Outer diameter: minimum 26 mm, maximum 30 mm, hole diameter: 13 mm, thickness: 3 mm.
Lifting shackle	-	SA-10-8-NA1
Roundsling, 1.5 m	-	Length: 1.5 m. Lifting capacity: 2,000 kg.
Roundsling, 1 m	-	Length: 1 m, lifting capacity: 1,000 kg.
Lifting accessory (chain)	3HAC15556-1	Lifting instruction 3HAC15880-2 enclosed.
Rotation tool	3HAB7887-1	Used to rotate the motor pinion.
24 VDC power supply	-	Used to release the motor brakes.
Removal tool kit M12 and M14	3HAC057339-002	Used to push out the motor, if necessary. Always use removal tools in pairs. Size depending on motor type, see Type A vs type B motors on page 805 .
Guide pin, M16x150	3HAC13120-2	Always use guide pins in pairs.
Guide pin, M16x200	3HAC13120-3	Always use guide pins in pairs.
Guide pin, M12x150	3HAC13056-2	Always use guide pins in pairs.
Guide pin, M12x200	3HAC13056-3	Always use guide pins in pairs.
Aligning tool	3HAC046645-003	Used for aligning the gearbox against the frame, so that the play in the motor does not need to be adjusted.
Guide pin, M10x150	3HAC15521-2	Always use guide pins in pairs.
Lifting accessory, gearbox	3HAC046112-001	
Hydraulic cylinder	3HAC11731-1	To be used with the press and puller tools. See technical specifications in the user instructions for the press equipment.

Continues on next page

4 Repair

4.8.3 Replacing the axis-2 gearbox (IRB 6700 - 235/2.65, IRB 6700 - 205/2.80, IRB 6700 - 175/3.05, IRB 6700 - 150/3.20, IRB 6700 - 200/2.60, IRB 6700 - 155/2.85)

Continued

Equipment, etc.	Article number	Note
Hydraulic pump 80 MPa	3HAC13086-1	To be used with the press and puller tools. See technical specifications in the user instructions for the press equipment.
Leak-down tester	-	
Calibration Pendulum toolkit	3HAC15716-1	Required if Calibration Pendulum is the valid calibration method for the robot.
Calibration tool box, Axis Calibration	3HAC055412-001	Delivered as a set of calibration tools. Required if Axis Calibration is the valid calibration method for the robot.
Standard toolkit	-	Content is defined in section Standard toolkit on page 814 .

Required documents

Document name	Document number	Note
<i>Technical reference manual - Lubrication in gearboxes</i>	3HAC042927-001	

Deciding calibration routine

Decide which calibration routine to be used, based on the information in the table. Depending on which routine is chosen, action might be required prior to beginning the repair work of the robot, see the table.

	Action	Note
1	Decide which calibration routine to use for calibrating the robot. <ul style="list-style-type: none"> Reference calibration. External cable packages (DressPack) and tools can stay fitted on the robot. Fine calibration. All external cable packages (DressPack) and tools must be removed from the robot. 	
	If the robot is to be calibrated with reference calibration: Find previous reference values for the axis or create new reference values. These values are to be used after the repair procedure is completed, for calibration of the robot. If no previous reference values exist, and no new reference values can be created, then reference calibration is not possible.	Follow the instructions given in the reference calibration routine on the FlexPendant to create reference values. Creating new values requires possibility to move the robot. Read more about reference calibration for Axis Calibration in Reference calibration routine on page 782 . Read more about reference calibration for Pendulum Calibration in <i>Operating manual - Calibration Pendulum</i> .
	If the robot is to be calibrated with fine calibration: Remove all external cable packages (DressPack) and tools from the robot.	

Removing the axis-2 gearbox

Use these procedures to remove the gearbox.

Continues on next page

4.8.3 Replacing the axis-2 gearbox (IRB 6700 - 235/2.65, IRB 6700 - 205/2.80, IRB 6700 - 175/3.05, IRB 6700 - 150/3.20, IRB 6700 - 200/2.60, IRB 6700 - 155/2.85)

Continued

Follow the order of the procedures according to the order they are presented.

**CAUTION**

When performing these procedures, the cable harness will still be fitted or partly fitted to the robot. Use extreme caution not to cause any damage to the cable harness.

Preparations before replacing the axis-2 gearbox

	Action	Note
1	Decide which calibration routine to use, and take actions accordingly prior to beginning the repair procedure.	
2	 DANGER Turn off all: <ul style="list-style-type: none"> • electric power supply • hydraulic pressure supply • air pressure supply to the robot, before entering the robot working area.	
3	Begin draining the gearbox.	See Draining the axis-2 gearbox on page 155 .

Unloading the balancing device springs with the robot and locking position with the Distance tool

Use this procedure to unload the balancing device with the help of the robot, and lock the balancing device springs in a compressed position, using the Distance tool (3HAC030662-001).





	Action	Note
1	 DANGER Do not use the Distance tool (3HAC030662-001) to unload or restore the pressure of the balancing device springs! This tool is only used to lock the spring unit in a compressed position, after axis-2 has been jogged to -30° or $+30^\circ$. Fitting and removal of the tool shall only be done with axis-2 in this position! To unload or restore a new balancing device or if the spring unit of the balancing device cannot be compressed by jogging the robot, only use the Hydraulic press equipment, balancing device (3HAC074411-001).	
2	Jog axis-2 to: <ul style="list-style-type: none"> • -30° or $+30^\circ$ 	This is done in order to compress the balancing device springs inside the balancing device before fitting the Distance tool.

Continues on next page

4 Repair

4.8.3 Replacing the axis-2 gearbox (IRB 6700 - 235/2.65, IRB 6700 - 205/2.80, IRB 6700 - 175/3.05, IRB 6700 - 150/3.20, IRB 6700 - 200/2.60, IRB 6700 - 155/2.85)

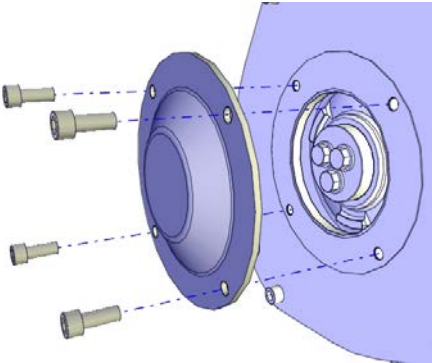
Continued

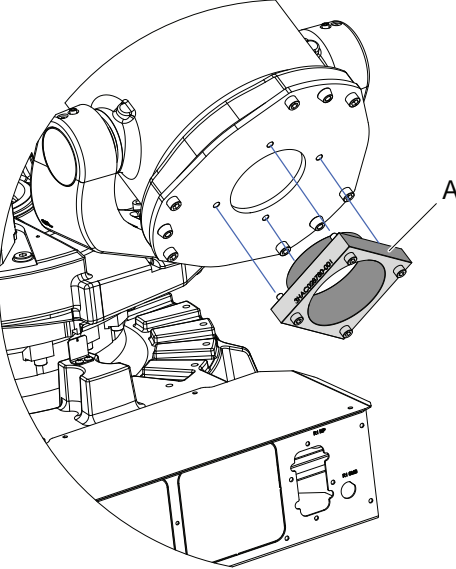
	Action	Note
3	<p> DANGER</p> <p>Turn off all:</p> <ul style="list-style-type: none"> • electric power supply • hydraulic pressure supply • air pressure supply <p>to the robot, before entering the robot working area.</p>	
4	<p>Remove the cover plate on the back of the balancing device.</p> <p> DANGER</p> <p>DO NOT remove any other screws than the rear cover attachment screws.</p>	 <p>xx1300000554</p>
5	<p>Fit the Distance tool on the back of the balancing device using the four screws.</p> <p> DANGER</p> <p>Use caution when tightening the screws. The threads in the cover can be damaged if more tightening torque than 45 Nm is used, risking that the Distance tool is not properly fitted.</p>	<p>Tightening torque: 45 Nm Attachment screws: M10 quality 12.9 (4 pcs)</p>  <p>xx0800000480</p> <p>A Distance tool: 3HAC030662-001</p>
6	Turn the power on temporary.	
7	Jog axis-2 to the calibration position. The balancing device is now unloaded.	This is done to compress the balancing device springs, making it possible to remove the front shaft of the balancing device.
8	Let the Distance tool stay fitted during the continued procedure.	

Continues on next page

4.8.3 Replacing the axis-2 gearbox (IRB 6700 - 235/2.65, IRB 6700 - 205/2.80, IRB 6700 - 175/3.05, IRB 6700 - 150/3.20, IRB 6700 - 200/2.60, IRB 6700 - 155/2.85)

Continued

	Action	Note
9	 DANGER Turn off all: <ul style="list-style-type: none"> • electric power supply • hydraulic pressure supply • air pressure supply to the robot, before entering the robot working area.	

Attaching lifting accessory to the balancing device

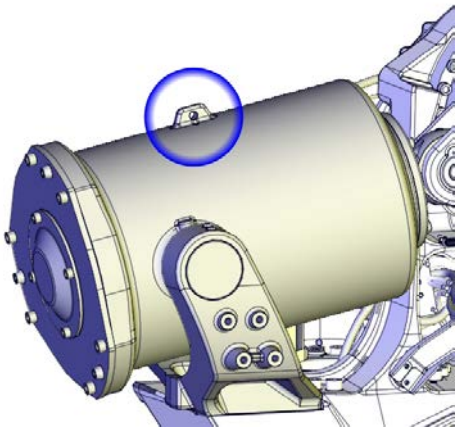
	Action	Note
1	 CAUTION The weight of the balancing device (excluding cradle) is 140 kg (IRB 6700 -235/2.65, -205/2.80, -175/3.05, -150/3.20, -200/2.60, -155/2.85) 185 kg (IRB 6700 -300/2.70, -245/3.00) All lifting accessories used must be sized accordingly.	
2	Fit a lifting shackle to the balancing device.	Lifting shackle: SA-10-8-NA1  xx130000661
3	Fit the lifting accessory to the shackle and raise to unload the weight.	Lifting accessory (chain): 3HAC15556-1

Continues on next page

4 Repair

4.8.3 Replacing the axis-2 gearbox (IRB 6700 - 235/2.65, IRB 6700 - 205/2.80, IRB 6700 - 175/3.05, IRB 6700 - 150/3.20, IRB 6700 - 200/2.60, IRB 6700 - 155/2.85)

Continued

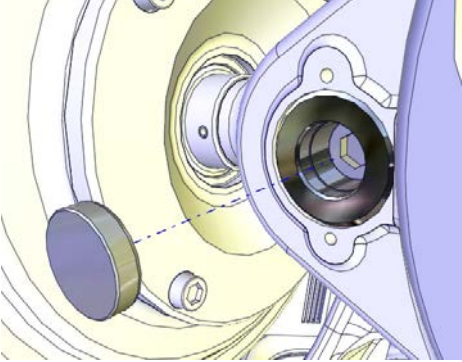
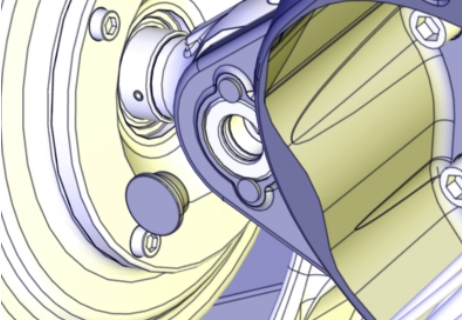
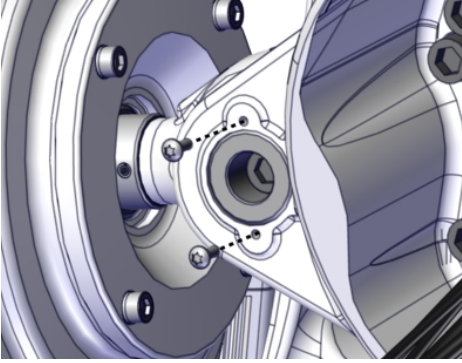

Removing the shaft in the front (link ear)

	Action	Note
1	Remove the protection plug or VK cover at the link ear (depends on shaft version).	<p>It is possible to drive a screwdriver (or similar) through the VK cover, as close as possible to the center of the VK cover and pull it out.</p>  <p>xx1200001278</p>  <p>xx1900002311</p>
2	Remove the two screws.	 <p>xx1900002146</p>

Continues on next page

4.8.3 Replacing the axis-2 gearbox (IRB 6700 - 235/2.65, IRB 6700 - 205/2.80, IRB 6700 - 175/3.05, IRB 6700 - 150/3.20, IRB 6700 - 200/2.60, IRB 6700 - 155/2.85)

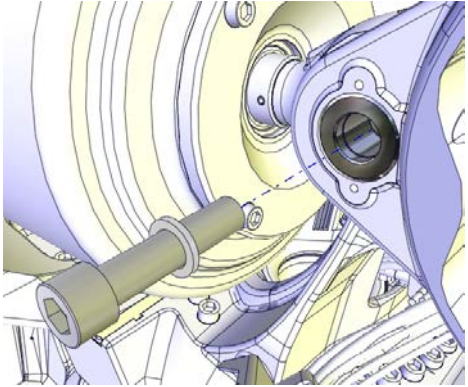
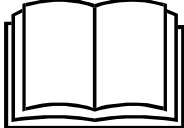
Continued

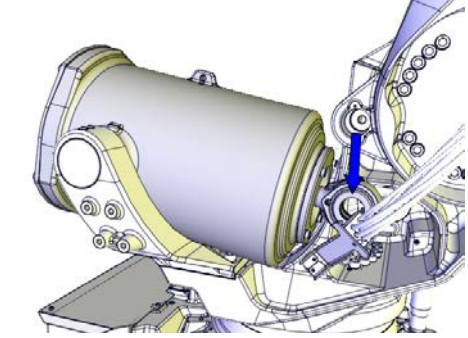
	Action	Note
3	Unscrew the attachment screw and washer.	 <p>xx1200001279</p> <ul style="list-style-type: none"> • M16x70 quality steel 8.8-A3F
4	Pull the shaft out using the dismantle and mounting tool, according to user instructions enclosed with the equipment.  <p>xx0900000813</p> <p>Go to the user instructions enclosed with the press tool.</p> <p> DANGER</p> <p>Handling the tool incorrectly will cause serious injury. Read and follow enclosed user instructions for the tool.</p>	Dismantle and mounting tool: 3HAC028920-001 User instructions are enclosed with the tool.
5	Put down the balancing device and let it rest on the frame.	 <p>xx1200001281</p>

Robot position

Use this procedure to jog the robot into position.



Continues on next page

4 Repair

4.8.3 Replacing the axis-2 gearbox (IRB 6700 - 235/2.65, IRB 6700 - 205/2.80, IRB 6700 - 175/3.05, IRB 6700 - 150/3.20, IRB 6700 - 200/2.60, IRB 6700 - 155/2.85)

Continued

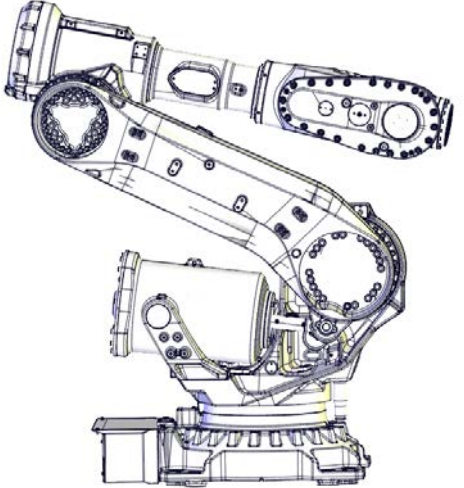
Valid for variants IRB 6700 - 235/2.65, IRB 6700 - 205/2.80, IRB 6700 - 175/3.05, IRB 6700 - 150/3.20, IRB 6700 - 200/2.60, IRB 6700 - 155/2.85.

	Action	Note
1	 Note When jogging the axis-2 into position check that the balancing device ear and the ear on the lower arm is not colliding!	
2	Jog the robot into position: <ul style="list-style-type: none"> • Axis-1: no significance as long as the robot is secured to the foundation • Axis-2: -45° • Axis-3: +65° (approximately) • Axis-4: 0° • Axis-5: 0° • Axis-6: 0°. 	
3	 DANGER Turn off all: <ul style="list-style-type: none"> • electric power supply • hydraulic pressure supply • air pressure supply to the robot, before entering the robot working area.	

Attaching lifting accessories to the lower and upper arm

Use this procedure to attach the lifting accessories.



Valid for variants IRB 6700 - 235/2.65, IRB 6700 - 205/2.80, IRB 6700 - 175/3.05, IRB 6700 - 150/3.20, IRB 6700 - 200/2.60, IRB 6700 - 155/2.85.

	Action	Note
1	 CAUTION The lower and upper arms together weigh (according to variants) 510 kg. All lifting accessories used must be sized accordingly!	

Continues on next page

4.8.3 Replacing the axis-2 gearbox (IRB 6700 - 235/2.65, IRB 6700 - 205/2.80, IRB 6700 - 175/3.05, IRB 6700 - 150/3.20, IRB 6700 - 200/2.60, IRB 6700 - 155/2.85)

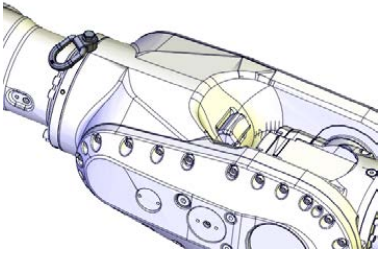
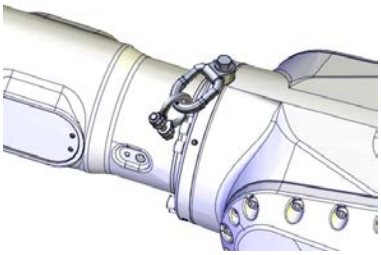
Continued

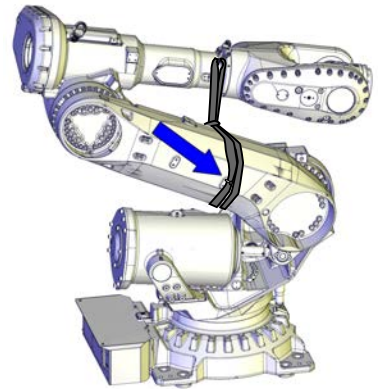



	Action	Note
2	Fit a lifting eye to the wrist.	<p>Lifting eye: 3HAC16131-1</p>  <p>xx1200001133</p>
3	Fit a lifting shackle in the wrist lifting eye.	<p>Lifting shackle: SA-10-8-NA1</p>  <p>xx1200001234</p>
4	<p>Insert a M8x50 securing screw, not more than 10-15 mm, into the screw hole shown in the figure. This is done to secure the roundsling from gliding when lifting.</p> <p>If DressPack cable package is installed: use the ball joint housing instead, in the same way.</p>	 <p>xx1200001251</p>
5	<p>Run a roundsling around the lower arm, beneath the securing screw.</p> <p>If DressPack cable package is installed: place the roundsling beneath the ball joint housing on the outside of the lower arm instead.</p>	<p>Roundsling, 1.5 m: Length: 1.5 m. Lifting capacity: 2,000 kg.</p>  <p>xx1200001252</p>

Continues on next page

4 Repair

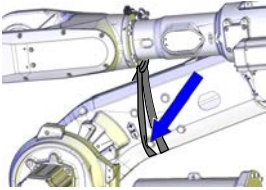
4.8.3 Replacing the axis-2 gearbox (IRB 6700 - 235/2.65, IRB 6700 - 205/2.80, IRB 6700 - 175/3.05, IRB 6700 - 150/3.20, IRB 6700 - 200/2.60, IRB 6700 - 155/2.85)

Continued

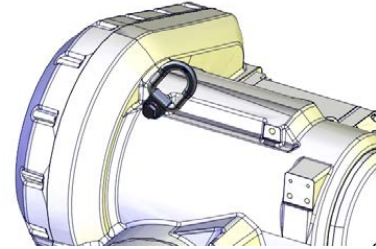
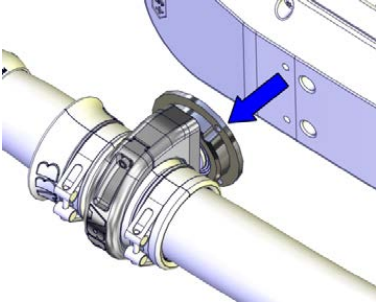
	Action	Note
6	Adjust the roundsling on the other side of the lower arm, so that the roundsling runs on the left side of the most lower of the four bosses. This will prevent the roundsling from gliding.	
7	Attach the roundsling to the shackle on the wrist.	 xx1200001253
8	Stretch the roundsling between the wrist and the lower arm by slowly jogging the axis-3.  Note Make sure the roundsling is stretched, in order to carry the weight of the lower arm.	
9	 DANGER Turn off all: <ul style="list-style-type: none"> • electric power supply • hydraulic pressure supply • air pressure supply to the robot, before entering the robot working area.	
10	Fit a lifting eye in the arm house, with a fender washer underneath.  xx1400002196	Lifting eye: 3HAC16131-1 Fender washer: Outer diameter: minimum 26 mm, maximum 30 mm, hole diameter: 13 mm, thickness: 3 mm.  xx1200001134
11	If the robot is equipped with DressPack, unscrew the attachment screws of the bracket that holds the ball joint housings on the wrist. The DressPack can stay fitted in the ball joint housing.	 xx1400000355
12	Move the DressPack cable package over to the other side of where the lifting accessory will be attached to the shackle on the arm house.	

Continues on next page

4.8.3 Replacing the axis-2 gearbox (IRB 6700 - 235/2.65, IRB 6700 - 205/2.80, IRB 6700 - 175/3.05, IRB 6700 - 150/3.20, IRB 6700 - 200/2.60, IRB 6700 - 155/2.85)

Continued

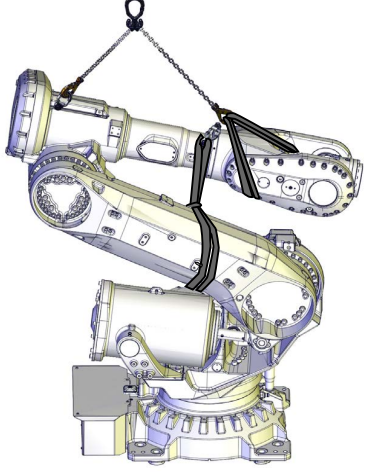
	Action	Note
13	Attach the Lifting accessory (chain) to an overhead crane (or similar), then to the lifting eye in the arm house and to a roundsling run through the wrist.	<p>Lifting accessory (chain): 3HAC15556-1 Roundsling, 1 m: Length: 1 m, lifting capacity: 1,000 kg.</p>  <p>xx1200001254</p>
14	Raise the overhead crane to stretch the chains and roundslings. Verify that the roundsling between the wrist and the lower arm is stretched.	
15	To release the brake, connect the 24 VDC power supply. Connect to connector R2.MP2, axis-2 motor: <ul style="list-style-type: none"> • + = pin 2 • - = pin 5 	

Disconnecting the axis-2 motor cables

Use this procedure to disconnect the motor cables.

	Action	Note
1	 <p>DANGER</p> <p>Make sure that all supplies for electrical power, hydraulic pressure, and air pressure are turned off.</p>	

Continues on next page

4 Repair

4.8.3 Replacing the axis-2 gearbox (IRB 6700 - 235/2.65, IRB 6700 - 205/2.80, IRB 6700 - 175/3.05, IRB 6700 - 150/3.20, IRB 6700 - 200/2.60, IRB 6700 - 155/2.85)

Continued

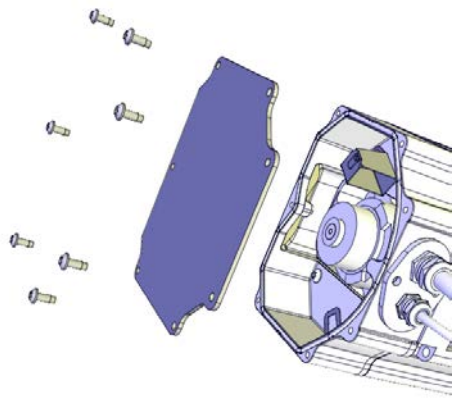
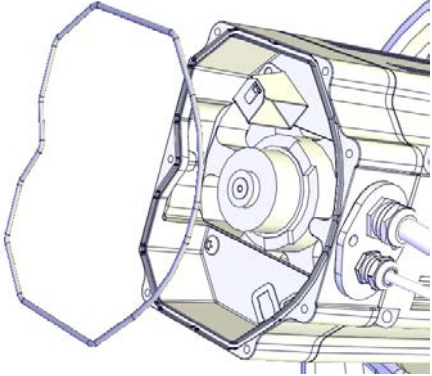
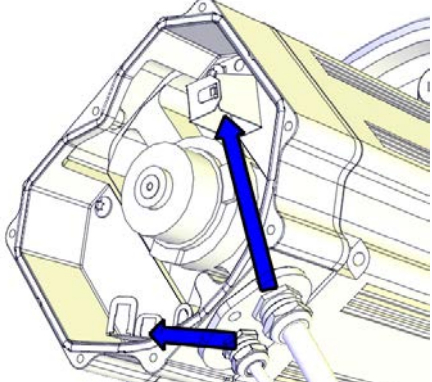
	Action	Note
2	Unscrew the attachment screws and washers and remove the motor cover.	 xx1200001135
3	Make sure the o-ring is present.	 xx1200001070
4	Disconnect the motor cables.	 xx1200001066

Continues on next page

4.8.3 Replacing the axis-2 gearbox (IRB 6700 - 235/2.65, IRB 6700 - 205/2.80, IRB 6700 - 175/3.05, IRB 6700 - 150/3.20, IRB 6700 - 200/2.60, IRB 6700 - 155/2.85)

Continued

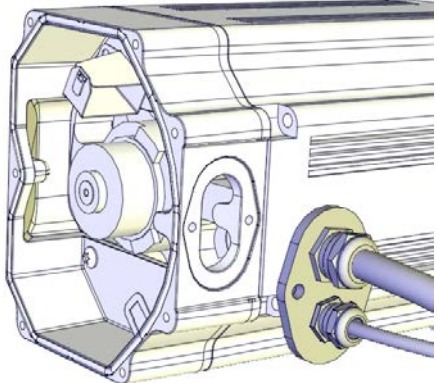
	Action	Note
5	<p>Remove the cable gland cover. Make sure the gasket is not damaged.</p> <p> Tip</p> <p>Make a note in which direction the cable gland hole is facing, if the motor will be removed too. The motor shall be refitted in the same position.</p>	 <p>xx1200001067</p>
6	Use caution and pull out the motor cables.	

Removing the axis-2 motor

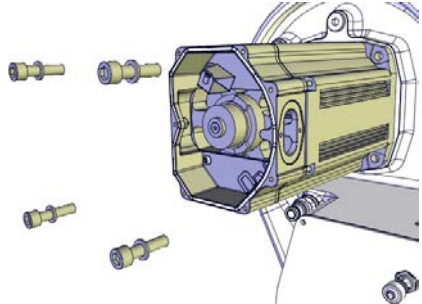

	Action	Note
1	Before removing the motor, make sure that the axis-2 gearbox is completely drained.	
2	<p> DANGER</p> <p>When releasing the holding brakes of the motor, the lower arm will be movable and may fall down if not secured. Verify that the lower arm is secured as previously described, before continuing.</p>	
3	<p>To release the brake, connect the 24 VDC power supply.</p> <p>Connect to connector R2.MP2, axis-2 motor:</p> <ul style="list-style-type: none"> • + = pin 2 • - = pin 5 	
4	<p>Remove the attachment screws.</p> <p>Use a bits extender in order to reach the screws.</p>	<p>Bits extender: 3HAC12342-1</p>  <p>xx1200001117</p>

Continues on next page

4 Repair

4.8.3 Replacing the axis-2 gearbox (IRB 6700 - 235/2.65, IRB 6700 - 205/2.80, IRB 6700 - 175/3.05, IRB 6700 - 150/3.20, IRB 6700 - 200/2.60, IRB 6700 - 155/2.85)

Continued

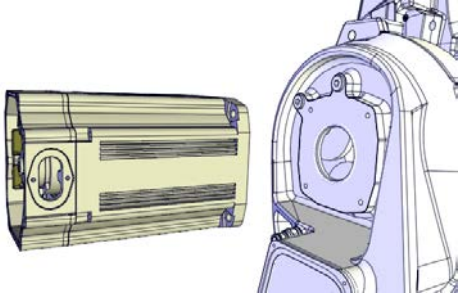
	Action	Note
5	Fit guide pins in opposite holes.  Tip Lubricate the guide pins with some grease to make the motor slide better.	Guide pin, M10x150: 3HAC15521-2 Always use guide pins in pairs.
6	 CAUTION Whenever parting/mating motor and gearbox, the gears may be damaged if excessive force is used.	
7	If required, press the motor out of its position by using the removal tool in opposite holes of the motor.	Removal tool kit M12 and M14: 3HAC057339-002 Removal tool kit M12 and M14: 3HAC057339-002 Depending on motor type A or B, see Identifying the motor by article number on page 805 Always use removal tools in pairs.
8	Disconnect the 24 VDC power supply.	
9	 CAUTION The motor weighs 28 kg. All lifting accessories used must be sized accordingly.	
10	Carefully lift the motor out on the guide pins, in order to get the pinion away from the gear and let it rest on the guide pins.	
11	Fasten the lifting accessory. Attach the lifting chain to the accessory and an overhead crane.	Lifting accessory, motor: 3HAC15534-1 Lifting accessory (chain): 3HAC15556-1
12	Remove the motor by sliding it out on the guide pins and lift it off.	Make sure the pinion is not damaged.  xx1200001118



Continues on next page

4.8.3 Replacing the axis-2 gearbox (IRB 6700 - 235/2.65, IRB 6700 - 205/2.80, IRB 6700 - 175/3.05, IRB 6700 - 150/3.20, IRB 6700 - 200/2.60, IRB 6700 - 155/2.85)

Continued

Loosening the cable brackets

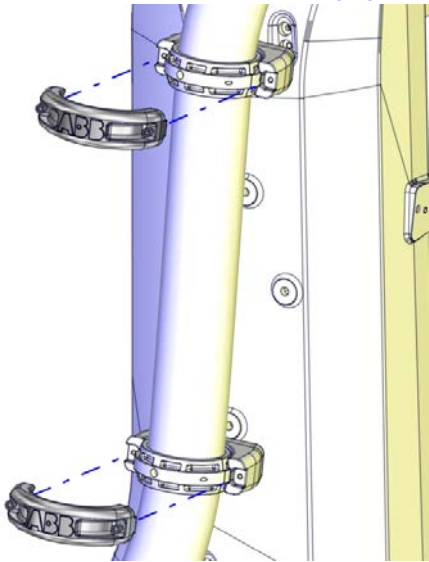
Use this procedure to lift the lower and upper arm un-separated.

	Action	Note
1	<p>If robot is equipped with DressPack:</p> <ul style="list-style-type: none"> Open the two ball joint housings from the lower arm and lift away the cabling from the ball joint housings. 	<p>How to remove the DressPack cable package is described in more detail in the product manual "IRB 6700 DressPack". For article number see References on page 10.</p>  <p>xx140000195</p>
2	<p>Unscrew the attachment screws that secure the axis-2 lower arm metal clamp and the axis-3 lower arm metal clamp located on the inside of the lower arm by removing the attachment screws.</p> <p> Note</p> <p>The screws are reached from outside the lower arm!</p>	 <p>xx1300000540</p>

Continues on next page

4 Repair

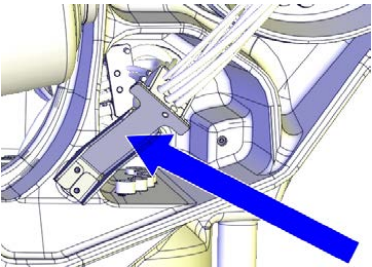

4.8.3 Replacing the axis-2 gearbox (IRB 6700 - 235/2.65, IRB 6700 - 205/2.80, IRB 6700 - 175/3.05, IRB 6700 - 150/3.20, IRB 6700 - 200/2.60, IRB 6700 - 155/2.85)

Continued

	Action	Note
3	Unscrew the attachment screws of the cable bracket on the frame and let it hang loose.	 xx1200001283

Removing and lifting away the lower and upper arms un-separated (Step 1)

Use this procedure for the first step of removing and lifting away the lower and upper arm un-separated.

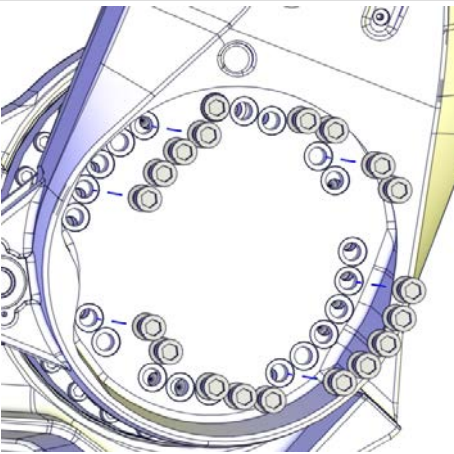
	Action	Note
1	Remove two attachment screws in opposite holes and replace them with guide pins.  Tip Lubricate the guide pins with some grease to make the lower arm slide better.	Guide pin, M16x150: 3HAC13120-2 Guide pin, M16x200: 3HAC13120-3 Always use guide pins in pairs.  xx1300000788
2	Remove all but one of the remaining attachment screws that secure the lower arm to the axis-2 gearbox.	 xx1300000789



Continues on next page

4.8.3 Replacing the axis-2 gearbox (IRB 6700 - 235/2.65, IRB 6700 - 205/2.80, IRB 6700 - 175/3.05, IRB 6700 - 150/3.20, IRB 6700 - 200/2.60, IRB 6700 - 155/2.85)

Continued

Removing and lifting away the lower and upper arms un-separated (Step 2)

Use this procedure for the second step to remove and lift the lower and upper arm un-separated.

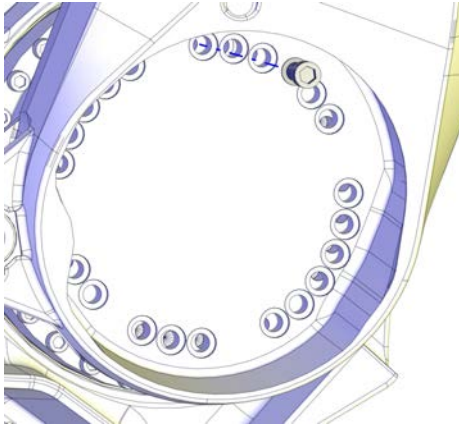
Action	Note
<p>1 Put two pallets on the floor, in front of the position of the mechanical stop.</p> <p> Note</p> <p>Using the method to replace the gearbox with cable harness and DressPack fitted, is only a recommendation. If it is not possible to put the arm system close enough to the robot and keep the cable harness partly fitted, it may be necessary to remove the cable harness and DressPack in base and frame first.</p>	
<p>2  CAUTION</p> <p>The lower and upper arms together weigh 510 kg. All lifting accessories used must be sized accordingly!</p>	
<p>3 Use caution and remove the remaining screw and slowly lift away the lower and upper arm together.</p> <p>Let the cabling run in the lower arm. Make sure not to stretch any cabling!</p> <p> CAUTION</p> <p>Use extreme caution when lifting the upper arm. The cable harness is still partly connected.</p>	 <p style="font-size: small;">xx130000790</p>
<p>4 Use a piece of wood or similar as a support under the arm house when the arm system is put down on the pallets.</p> <p>This is done in order not to damage any parts of the cable harness and DressPack.</p>	
<p>5 Use caution and lift the arm system and lay it down safely on the pallets.</p>	

Continues on next page



4 Repair

4.8.3 Replacing the axis-2 gearbox (IRB 6700 - 235/2.65, IRB 6700 - 205/2.80, IRB 6700 - 175/3.05, IRB 6700 - 150/3.20, IRB 6700 - 200/2.60, IRB 6700 - 155/2.85)

Continued

Removing the axis-2 gearbox

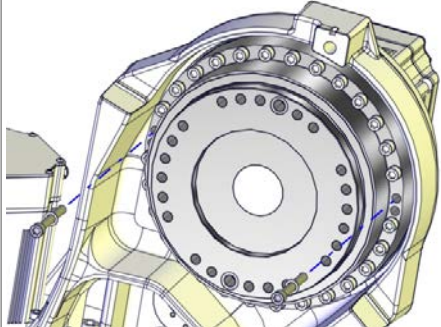
Use the procedure to remove gearbox.

	Action	Note
1	<p>Remove two attachment screws in opposite holes and replace them with guide pins.</p> <p> Tip</p> <p>Lubricate the guide pins with some grease to make the gearbox slide better.</p>	<p>Guide pin, M12x150: 3HAC13056-2 Guide pin, M12x200: 3HAC13056-3 Always use guide pins in pairs.</p>  <p>xx1300002249</p>
2	<p>Leave one of the upper attachment screws and remove the rest. The remaining screw is used to prevent the gearbox from falling down.</p>	
3	<p> CAUTION</p> <p>The gearbox weighs 83 kg. All lifting accessories used must be sized accordingly.</p>	
4	<p>Remove the remaining screw left in the gearbox.</p>	
5	<p>Use two fully threaded attachment screws (M12) as removal tools to press the gearbox out of position.</p>	
6	<p>Attach the lifting accessory to the gearbox.</p>	<p>Lifting accessory, gearbox: 3HAC046112-001</p>
7	<p>Use caution and let the gearbox slide out on the guide pins.</p>	
8	<p>Remove the gearbox.</p>	

Refitting the axis-2 gearbox

Use these procedures to refit the gearbox.

Follow the order of the procedures according to the order they are presented.



CAUTION

When performing these procedures, the cable harness will still be fitted or partly fitted to the robot. Use extreme caution not to cause any damage to the cable harness!



Continues on next page

4.8.3 Replacing the axis-2 gearbox (IRB 6700 - 235/2.65, IRB 6700 - 205/2.80, IRB 6700 - 175/3.05, IRB 6700 - 150/3.20, IRB 6700 - 200/2.60, IRB 6700 - 155/2.85)

Continued

Refitting the gearbox

Use this procedure to refit the gearbox.

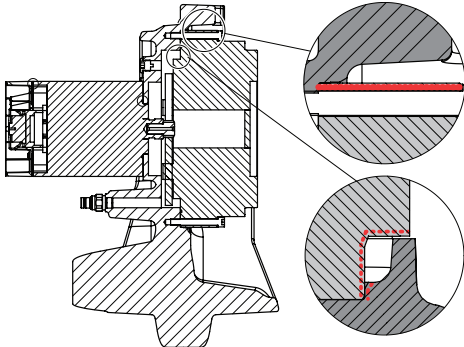
	Action	Note
1	 CAUTION The gearbox weighs 83 kg. All lifting accessories used must be sized accordingly!	
2	Apply the lifting accessory to the gearbox.	Lifting accessory, gearbox: 3HAC046112-001
3	Use caution and lift the gearbox so that it rests on its side.	
4	Remove the o-ring and wipe it clean.  Note This must also be done on a new spare part.	
5	Wipe clean the contact surfaces from any contamination.  Note Also wipe clean the o-ring groove.	
6	Check the condition of the o-ring. Replace if damaged.	O-ring: 3HAB3772-144 (D=309.3x3.1) / 3HAB3772-48 (D=319.3x5.7) Located between the gearbox and the frame. Size depends on gearbox model. Measure the groove to see dimension of the o-ring.
7	Lubricate the o-ring with some grease, for a better fitting in the groove.	
8	Fit the o-ring in the groove.	
9	<i>Foundry Plus:</i> Apply rust preventive to the gearbox surfaces shown in the figures.	Rust preventive: 3HAC034903-001 (Mercialsol 3110 Waxcoat. Recommended drying time is 24h.)  xx140000374

Continues on next page

4 Repair

4.8.3 Replacing the axis-2 gearbox (IRB 6700 - 235/2.65, IRB 6700 - 205/2.80, IRB 6700 - 175/3.05, IRB 6700 - 150/3.20, IRB 6700 - 200/2.60, IRB 6700 - 155/2.85)

Continued

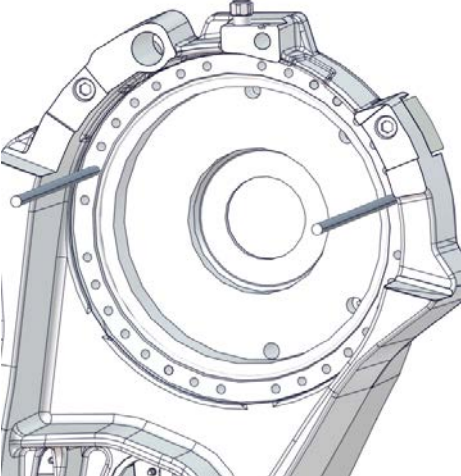
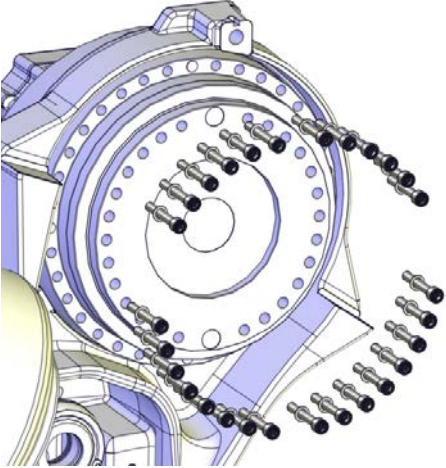

	Action	Note
10	Fit two guide pins in opposite holes (M12).  Tip Lubricate the guide pins with some grease to make the gearbox slide better.	Guide pin, M12x150: 3HAC13056-2 Guide pin, M12x200: 3HAC13056-3 Always use guide pins in pairs.  <small>xx1700000445</small>
11	Lift the gearbox and let it rest on the guide pins.	
12	Slide the gearbox into position.	
13	Fit the attachment screws and washers now accessible.	 <small>xx1400002188</small> Attachment screws: M12x90 12.9 Gleitmo (30 pcs).
14	Remove the lifting accessory.	
15	Remove the guide pins and fit the remaining attachment screws and washers.	
16	Secure the gearbox with its attachment screws.	Tightening torque: 120 Nm.

Continues on next page

4.8.3 Replacing the axis-2 gearbox (IRB 6700 - 235/2.65, IRB 6700 - 205/2.80, IRB 6700 - 175/3.05, IRB 6700 - 150/3.20, IRB 6700 - 200/2.60, IRB 6700 - 155/2.85)

Continued

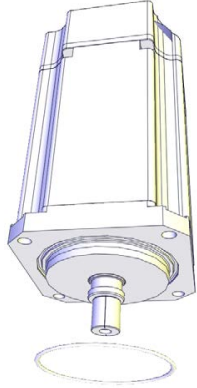
Preparations prior to refitting motor

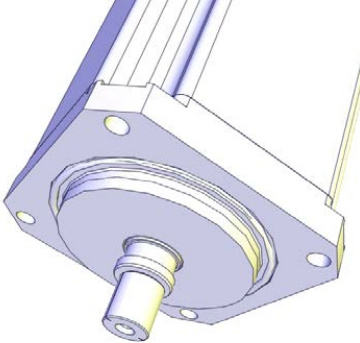
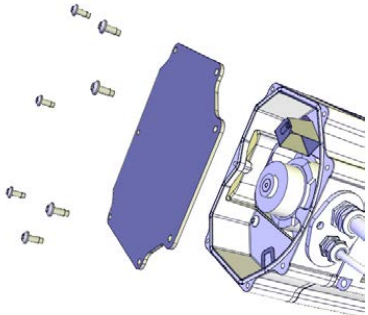
	Action	Note
1	 <p>DANGER</p> <p>Make sure that all supplies for electrical power, hydraulic pressure, and air pressure are turned off.</p>	
2	<p>Remove any old paint residues or other contamination from the contact surfaces on both the motor and the mating parts.</p> <p>Wipe clean the contact surfaces and the o-ring groove.</p>	
3	<p>Fit a new o-ring.</p>	 <p>xx1200001019</p>
4	 <p>Tip</p> <p>Lubricate the o-ring with some grease for a better fitting in the groove.</p>	 <p>xx1200001020</p>
5	<p>If the motor is a new spare part, remove the cover.</p>	 <p>xx1200001135</p>





Continues on next page

4 Repair

4.8.3 Replacing the axis-2 gearbox (IRB 6700 - 235/2.65, IRB 6700 - 205/2.80, IRB 6700 - 175/3.05, IRB 6700 - 150/3.20, IRB 6700 - 200/2.60, IRB 6700 - 155/2.85)

Continued

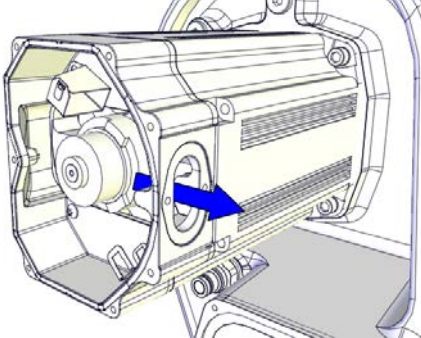
Securing the axis-2 motor

	Action	Note
1	Fit guide pins in opposite holes.	Guide pin, M10x150: 3HAC15521-2 Always use guide pins in pairs.
2	 CAUTION The motor weighs 28 kg. All lifting accessories used must be sized accordingly.	
3	Apply the lifting accessory.	Lifting accessory, motor: 3HAC15534-1 Lifting accessory (chain): 3HAC15556-1
4	 Note Make sure the cable gland opening is turned the correct way.	 xx1200001120
5	Lift the motor and put it on the guide pins as close as possible to its final position without pushing the motor pinion into the gear.	
6	Remove the lifting accessory and allow the motor to rest on the guide pins.	
7	Apply the rotation tool and use it to rotate the pinion when mating it into the gear.	Rotation tool: 3HAB7887-1
8	To release the brakes, connect the 24 VDC power supply. Connect to connector R2.MP2, axis-2 motor: <ul style="list-style-type: none"> • + = pin 2 • - = pin 5 	
9	 CAUTION Whenever parting/mating motor and gearbox, the gears may be damaged if excessive force is used.	

Continues on next page

4.8.3 Replacing the axis-2 gearbox (IRB 6700 - 235/2.65, IRB 6700 - 205/2.80, IRB 6700 - 175/3.05, IRB 6700 - 150/3.20, IRB 6700 - 200/2.60, IRB 6700 - 155/2.85)

Continued

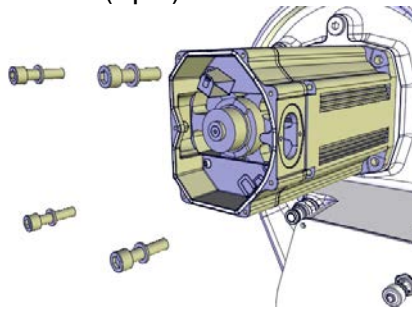
Action	Note
10	<p>Use caution and fit the motor in its final position while at the same time rotating the motor pinion slightly using the rotation tool.</p> <ul style="list-style-type: none"> • Make sure that the motor pinion is properly mated to the gear of the gearbox. • Make sure that the motor pinion does not get damaged. • Make sure that the direction of the cable exit is facing the correct way.
11	Fit two of the attachment screws and washers. Screws: M10x30 Steel 12.9 Gle 603+Geo500
12	Remove the guide pins and replace with the remaining attachment screws.
13	<p>Secure the motor with its attachment screws and washers. Use a bits extender in order to reach the screws.</p> <p>Bits extender: 3HAC12342-1 Tightening torque: 50 Nm. Screw dimension: M10x30 Steel 12.9 Gle 603+Geo500 (4 pcs)</p>  <p style="text-align: right; font-size: small;">xx1200001117</p>
14	Perform a leak-down test. See Performing a leak-down test on page 186.

Lifting back and refitting the lower and upper arm

Use this procedure to lift back and refit the lower and upper arm un-separated.



Action	Note
1	Connect the 24 VDC power supply to the axis-2 motor to release the brakes of the motor.
2	Fit the rotation tool, if not already fitted. Rotation tool: 3HAB7887-1

Continues on next page

4 Repair

4.8.3 Replacing the axis-2 gearbox (IRB 6700 - 235/2.65, IRB 6700 - 205/2.80, IRB 6700 - 175/3.05, IRB 6700 - 150/3.20, IRB 6700 - 200/2.60, IRB 6700 - 155/2.85)

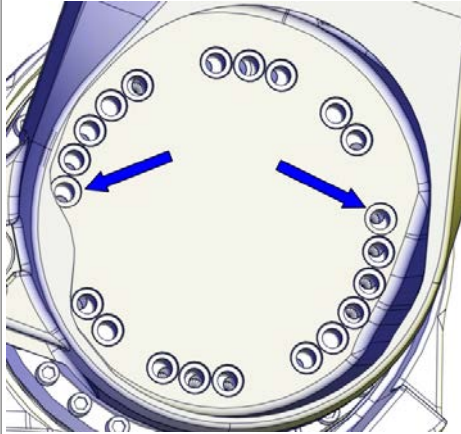
Continued

	Action	Note
3	<p>Fit two guide pins in opposite holes in the axis-2 gearbox.</p> <p> Tip</p> <p>Lubricate the guide pins with some grease to make the lower arm slide better.</p>	<p>Guide pin, M16x150: 3HAC13120-2 Always use guide pins in pairs.</p>  <p>xx1400000360</p>
4	<p> CAUTION</p> <p>The lower and upper arms together weigh 510 kg. All lifting accessories used must be sized accordingly!</p>	
5	<p>Attach the lifting accessories, if not already fitted.</p>	
6	<p>Clean all contact surfaces between lower arm and axis-2 gearbox.</p>	<p>Use: Cleaning agent. Isopropanol.</p>
7	<p>Use caution and slowly lift the lower and upper arm together.</p> <p>Make sure:</p> <ul style="list-style-type: none"> • not to stretch any of the cables • that the arm package is level when lifted. 	
8	<p>Before putting the arms on the guide pins, make sure that the hole pattern is matched and in the correct position for all screws.</p>	

Continues on next page

4.8.3 Replacing the axis-2 gearbox (IRB 6700 - 235/2.65, IRB 6700 - 205/2.80, IRB 6700 - 175/3.05, IRB 6700 - 150/3.20, IRB 6700 - 200/2.60, IRB 6700 - 155/2.85)

Continued

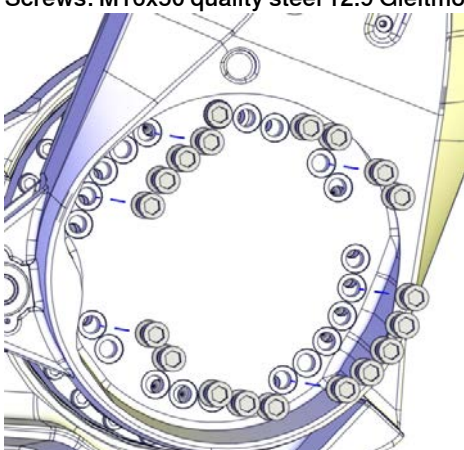
Action	Note
9	<p>If the hole pattern is not matching, use the rotation tool and adjust.</p> <p>Rotation tool: 3HAB7887-1</p>  <p style="text-align: right; font-size: small;">xx1300000819</p>
10	Slide the lower arm on to the guide pins.
11	Use caution and move the arms into position at the axis-2 gearbox on the guide pins.
12	<p>Fit all now accessible attachment screws and washers.</p> <p>Screws: M16x50 quality steel 12.9 Gleitmo</p>  <p style="text-align: right; font-size: small;">xx1300000789</p>
13	<p>Remove the two guide pins and replace with the remaining attachment screws and washers.</p> <p>Screws: M16x50 quality steel 12.9 Gleitmo</p>
14	<p>Secure the lower arm to the axis-2 gearbox with its attachment screws.</p> <p>Tightening torque M16: 300 Nm</p>
15	Disconnect the 24 VDC power supply.
16	Remove the lifting accessories.



Continues on next page

4 Repair

4.8.3 Replacing the axis-2 gearbox (IRB 6700 - 235/2.65, IRB 6700 - 205/2.80, IRB 6700 - 175/3.05, IRB 6700 - 150/3.20, IRB 6700 - 200/2.60, IRB 6700 - 155/2.85)

Continued

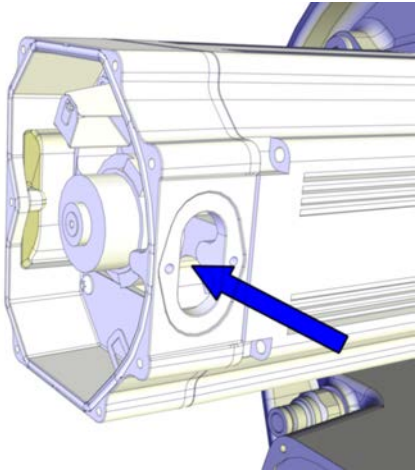

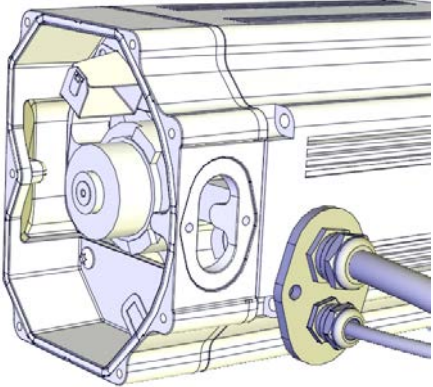
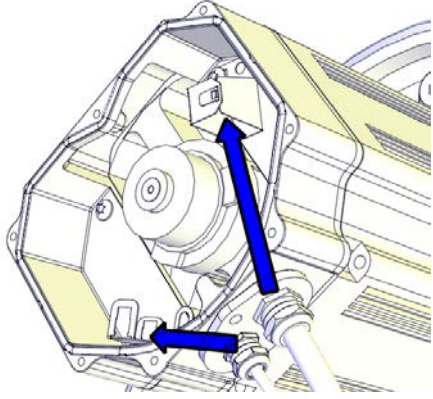
Connecting the axis-2 motor cables

	Action	Note
1	Push the motor cables through the cable gland opening.	 xx130000738
2	Refit the cable gland cover.  Note Replace the gasket if damaged.	 xx1200001067
3	Connect the motor cables. Connect in accordance with the markings on the connectors.	 xx1200001066

Continues on next page

4.8.3 Replacing the axis-2 gearbox (IRB 6700 - 235/2.65, IRB 6700 - 205/2.80, IRB 6700 - 175/3.05, IRB 6700 - 150/3.20, IRB 6700 - 200/2.60, IRB 6700 - 155/2.85)

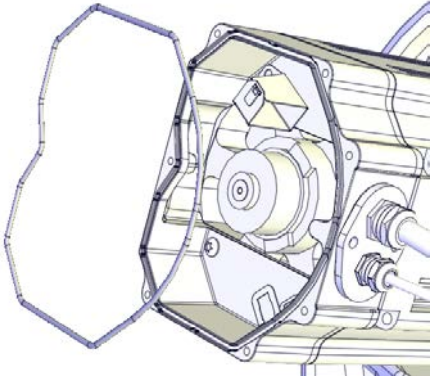
Continued



	Action	Note
4	<p>Inspect the o-ring.</p> <p> Note</p> <p>Replace if damaged.</p>	<p>O-ring, axis-1: 3HAB3772-111 (circular profile) / 3HAC054692-002 (hexagon profile)</p> <p>O-ring, axis-2: 3HAB3772-111 (circular profile) / 3HAC054692-002 (hexagon profile)</p> <p>O-ring, axis-3: 3HAB3772-111 (circular profile) / 3HAC054692-002 (hexagon profile)</p> <p>O-ring, axis-4: 3HAB3772-110 (circular profile) / 3HAC054692-001 (hexagon profile)</p>  <p>xx1200001070</p>
5	<p>Wipe clean o-ring and o-ring groove.</p>	
6	<p>Refit the o-ring.</p> <p> Tip</p> <p>Lubricate the o-ring with some grease for a better fitting in the groove.</p>	
7	<p> CAUTION</p> <p>When fitting the motor cover, make sure that none of the cables inside will be damaged.</p>	

Continues on next page

4 Repair

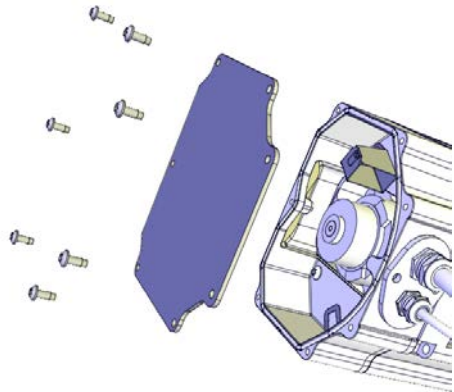

4.8.3 Replacing the axis-2 gearbox (IRB 6700 - 235/2.65, IRB 6700 - 205/2.80, IRB 6700 - 175/3.05, IRB 6700 - 150/3.20, IRB 6700 - 200/2.60, IRB 6700 - 155/2.85)

Continued

	Action	Note
8	<p>Refit the motor cover with its attachment screws.</p> <p> Note</p> <p>Do not reuse the self-threading attachment screws. Replace with standard attachment screws or the threads will be damaged.</p> <p> Note</p> <p>Make sure the o-ring is undamaged and properly fitted.</p>	<p>Attachment screws: M5x12 8.8 (7 pcs)</p>  <p>xx1200001135</p>
9	<p>Make sure that the covers are tightly sealed.</p>	

Refitting the cabling

Use this procedure to refit the cabling.

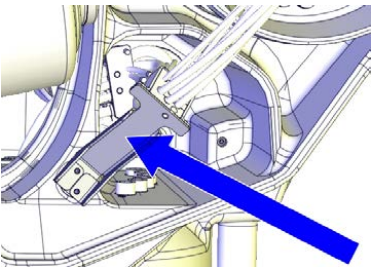
	Action	Note
1	<p>Use caution and push the cable harness into the lower arm.</p>	
2	<p>Refit the axis-2 lower arm metal clamp and the axis-3 lower arm metal clamp located on the inside of the lower arm.</p> <p> Note</p> <p>The screws are reached from the outside of the lower arm!</p>	 <p>xx1200001282</p>
3	<p>Refit the cable bracket on the frame.</p>	 <p>xx1200001283</p>

Continues on next page

4.8.3 Replacing the axis-2 gearbox (IRB 6700 - 235/2.65, IRB 6700 - 205/2.80, IRB 6700 - 175/3.05, IRB 6700 - 150/3.20, IRB 6700 - 200/2.60, IRB 6700 - 155/2.85)

Continued

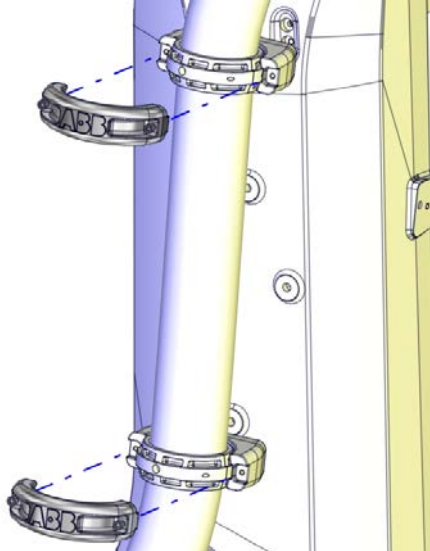
	Action	Note
4	If robot is equipped with DressPack. <ul style="list-style-type: none"> Place the cabling in the two ball joint housings on the lower arm and close the housings. 	How to refit the DressPack is described in the product manual "IRB 6700 DressPack". For article number see References on page 10 .  <p>xx140000195</p>

Refitting the front shaft of the balancing device



	Action	Note
1	Turn the power to the robot on temporarily.	
2	Use caution and jog the robot to the calibration position (if not already done).	
3	 DANGER Turn off all: <ul style="list-style-type: none"> electric power supply hydraulic pressure supply air pressure supply to the robot, before entering the robot working area.	
4	Apply the lifting accessory to the balancing device (if not already done).	Lifting shackle: SA-10-8-NA1 Lifting accessory (chain): 3HAC15556-1
5	Remove all residue of Loctite in the screw hole of the shaft.	
6	Wipe all contact surfaces inside the recess clean from contamination.	

Continues on next page

4 Repair

4.8.3 Replacing the axis-2 gearbox (IRB 6700 - 235/2.65, IRB 6700 - 205/2.80, IRB 6700 - 175/3.05, IRB 6700 - 150/3.20, IRB 6700 - 200/2.60, IRB 6700 - 155/2.85)

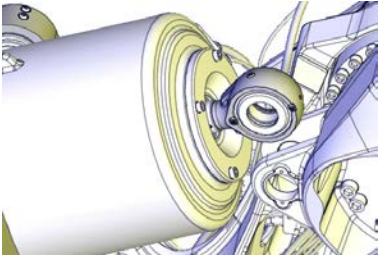
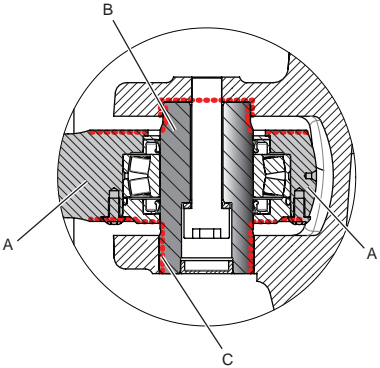

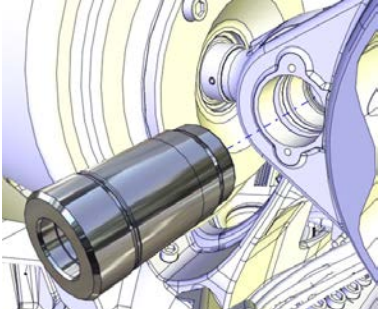
Continued

	Action	Note
7	<p>Align the balancing device link ear with the hole in the lower arm.</p> <p> Note</p> <p>Verify that the link ear is correctly turned.</p>	 <p>xx1300000784</p>
8	<p><i>Foundry Plus:</i></p> <p>Apply Mercasol on the surfaces on the shaft and front ear.</p>	 <p>xx1400000368</p> <p>A Front link ear B Shaft C Mercasol (red dotted lines)</p>
9	<p>Lubricate the shaft and place it to the front ear.</p> <p> Note</p> <p><i>Foundry Plus:</i></p> <p>Do not lubricate surfaces where Mercasol is applied.</p>	 <p>xx1200001280</p>

Continues on next page

4.8.3 Replacing the axis-2 gearbox (IRB 6700 - 235/2.65, IRB 6700 - 205/2.80, IRB 6700 - 175/3.05, IRB 6700 - 150/3.20, IRB 6700 - 200/2.60, IRB 6700 - 155/2.85)

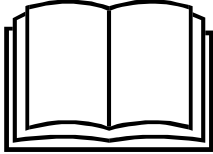
Continued

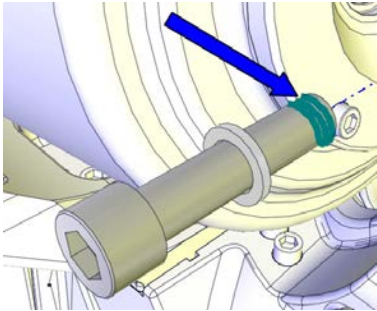
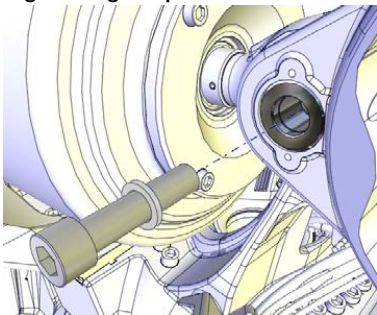
	Action	Note
10	<p>Press in the shaft using the dismantle and mounting tool, according to user instructions enclosed with the equipment.</p>  <p>xx0900000813</p> <p>Go to the user instructions enclosed with the press tool.</p> <p> DANGER</p> <p>Handling the tool incorrectly will cause serious injury. Read and follow enclosed user instructions for the tool.</p>	<p>Dismantle and mounting tool: 3HAC028920-001</p> <p>User instructions are enclosed with the tool.</p>
11	<p>Apply locking liquid (Loctite 2701) on the threads of the screw, first entering the threads in the frame.</p>	 <p>xx1300000782</p>
12	<p>Secure the shaft with screw and washer.</p>	<p>Tightening torque: 180 Nm</p>  <p>xx1200001279</p>

Continues on next page

4 Repair

4.8.3 Replacing the axis-2 gearbox (IRB 6700 - 235/2.65, IRB 6700 - 205/2.80, IRB 6700 - 175/3.05, IRB 6700 - 150/3.20, IRB 6700 - 200/2.60, IRB 6700 - 155/2.85)

Continued

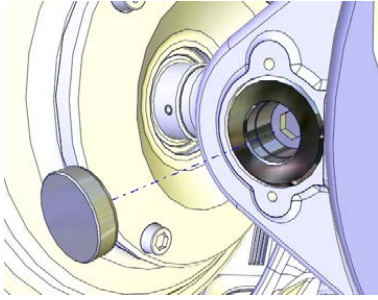
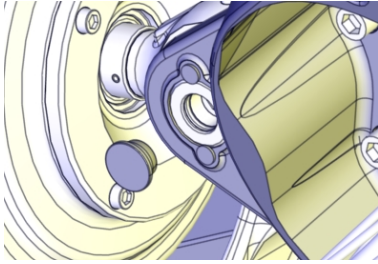
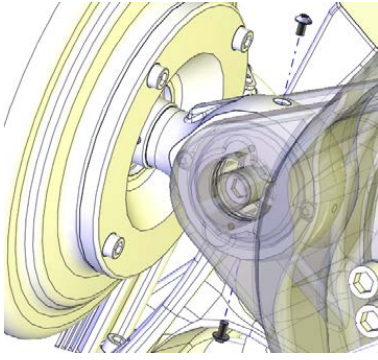
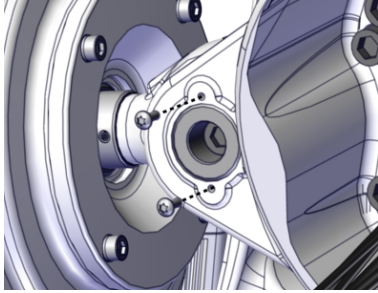
	Action	Note
13	Fit the protection plug or a new VK-cover (depends on shaft version).	 <p>xx1200001278</p>  <p>xx1900002311</p>
14	Unscrew both screws in link ear and fill the bearing with grease from the upper hole until the grease appears in the lower hole.	<p>Grease: 3HAA1001-294</p>  <p>xx1300000783</p>
15	Refit the two screws and wipe clean from residual grease.	<p>Tightening torque: 180 Nm</p>  <p>xx1900002146</p>



Concluded refitting of the front shaft

	Action	Note
1	Remove the lifting accessory from the balancing device.	

Continues on next page

4.8.3 Replacing the axis-2 gearbox (IRB 6700 - 235/2.65, IRB 6700 - 205/2.80, IRB 6700 - 175/3.05, IRB 6700 - 150/3.20, IRB 6700 - 200/2.60, IRB 6700 - 155/2.85)

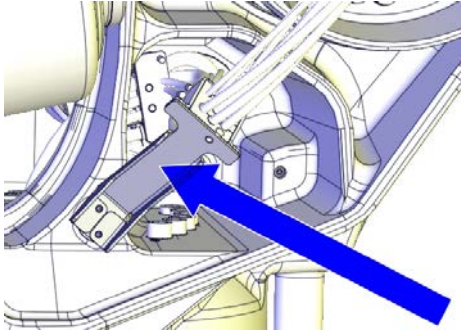
Continued

	Action	Note
2	Refit the cable bracket (if not already refitted).	 <p style="text-align: right; font-size: small;">xx1200001283</p>
3	<p style="text-align: center;"> DANGER</p> <p>Do not use the Distance tool: 3HAC030662-001 to unload or restore the pressure of the balancing device spring unit! This tool is only used to lock the spring unit in a compressed position, after axis-2 has been jogged to -20° or $+20^\circ$. Fitting and removal of the tool shall only be done with axis-2 in this position!</p> <p>To unload or restore a new balancing device or if the spring unit of the balancing device cannot be compressed by jogging the robot, only use the hydraulic press tool Dismantle and mounting tool 3HAC028920-001.</p>	
4	Jog axis-2 to: <ul style="list-style-type: none"> • -30° or $+30^\circ$. 	This is done in order to compress the spring unit inside the balancing device before refitting or removal of the distance tool.
5	<p style="text-align: center;"> DANGER</p> <p>Turn off all:</p> <ul style="list-style-type: none"> • electric power supply • hydraulic pressure supply • air pressure supply <p>to the robot, before entering the robot working area.</p>	

Continues on next page

4 Repair

4.8.3 Replacing the axis-2 gearbox (IRB 6700 - 235/2.65, IRB 6700 - 205/2.80, IRB 6700 - 175/3.05, IRB 6700 - 150/3.20, IRB 6700 - 200/2.60, IRB 6700 - 155/2.85)

Continued

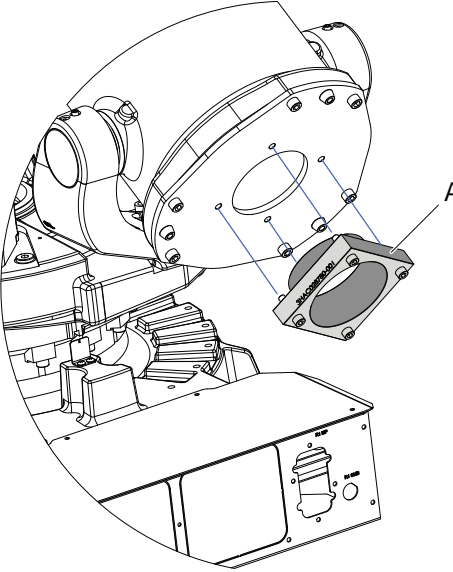
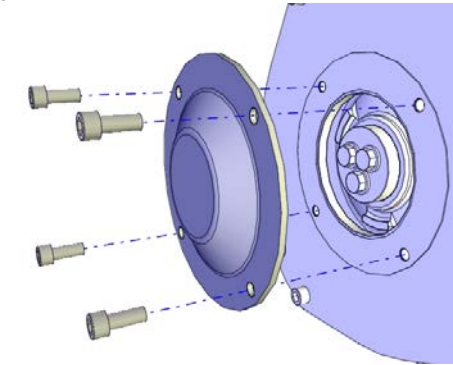
	Action	Note
6	Remove the distance tool.	 <p>xx0800000480</p> <p>A Distance tool: 3HAC030662-001</p>
7	Refit the cover plate.	<p>Attachment screws: M10 quality 12.9 (4 pcs)</p>  <p>xx1300000554</p>

Concluding procedure

	Action	Note
1	If the robot is equipped with DressPack, refit the brackets of the ball joint housings on the wrist.	
2	Refill oil to the axis-2 gearbox.	See Filling oil into the axis-2 gearbox on page 156 .
3	Re-calibrate the robot.	<p>Pendulum Calibration is described in Operating manual - Calibration Pendulum, enclosed with the calibration tools.</p> <p>Axis Calibration is described in Calibrating with Axis Calibration method on page 781.</p> <p>General calibration information is included in section Calibration on page 767.</p>

Continues on next page

4.8.3 Replacing the axis-2 gearbox (IRB 6700 - 235/2.65, IRB 6700 - 205/2.80, IRB 6700 - 175/3.05, IRB 6700 - 150/3.20, IRB 6700 - 200/2.60, IRB 6700 - 155/2.85)*Continued*

	Action	Note
4	 DANGER Make sure all safety requirements are met when performing the first test run.	

4 Repair

4.8.4 Replacing the axis-2 gearbox (IRB 6700 - 300/2.70, IRB 6700 - 245/3.00)

4.8.4 Replacing the axis-2 gearbox (IRB 6700 - 300/2.70, IRB 6700 - 245/3.00)

Validity of this section



Note

This section describes how to replace the gearbox on variants IRB 6700 - 300/2.70, IRB 6700 - 245/3.00.

How to replace the gearbox on variants IRB 6700 - 235/2.65, IRB 6700 - 205/2.80, IRB 6700 - 175/3.05, IRB 6700 - 150/3.20, IRB 6700 - 200/2.60, IRB 6700 - 155/2.85 see [Replacing the axis-2 gearbox \(IRB 6700 - 235/2.65, IRB 6700 - 205/2.80, IRB 6700 - 175/3.05, IRB 6700 - 150/3.20, IRB 6700 - 200/2.60, IRB 6700 - 155/2.85\) on page 642](#).

Space required beside

This section describes how to replace the gearbox without needing to remove the cable harness and DressPack cable package (if installed) from the robot.

The described procedure requires free space on the floor, in front of the lower arm, so that the upper and lower arm can be laid down with the cabling still attached to the robot. There should be enough space to place two pallets on the floor. If needed, run axis-1 into a position that gives the required space.



DANGER

The base shall be fitted to the foundation when performing this procedure! Valid in both examples described below!



Note

Using this method to replace the gearbox with cable harness and DressPack fitted, is only a recommendation. If it is not possible to put the arm system close enough to the robot and keep the cable harness partly fitted, it is necessary to remove the cable harness and DressPack in base and frame first.

Continues on next page

Location of the axis-2 gearbox

The axis-2 gearbox is located as shown in the figure.

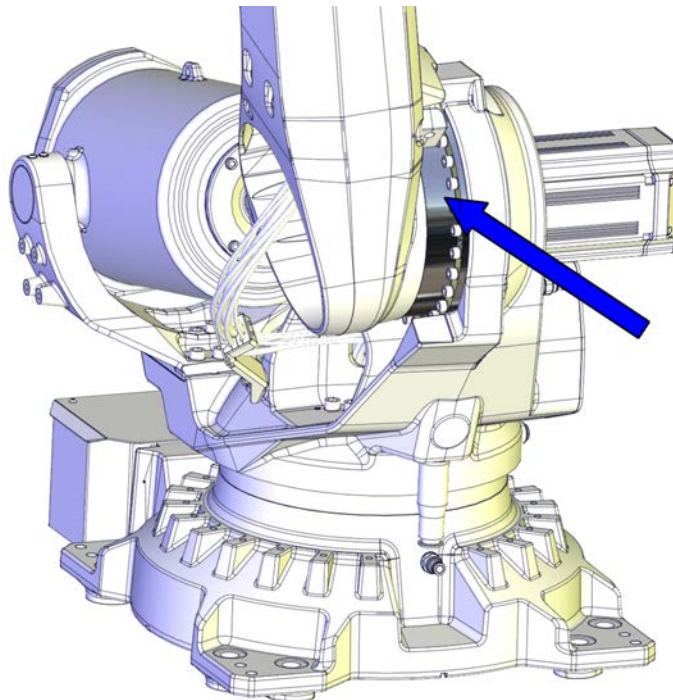

xx1200001276

Summary of the replacement procedure

This is a brief summary of the replacement procedure, containing the major actions to be performed.

- 1 Remove the upper and lower arm together, as a package.
- 2 Replace the axis-2 gearbox.

Spare parts

Spare parts	Article number	Note
Axis-2 gearbox	See <i>Product manual, spare parts - IRB 6700/IRB 6700Inv.</i>	

Required tools and equipment

Equipment, etc.	Article number	Note
Distance tool	3HAC030662-001	<p>Only used to keep the balancing device in a locked position, after the balancing device springs has been unloaded with the help of the robot itself.</p> <p> DANGER</p> <p><i>Never</i> use this tool to unload or restore a balancing device!</p>

Continues on next page

4 Repair

4.8.4 Replacing the axis-2 gearbox (IRB 6700 - 300/2.70, IRB 6700 - 245/3.00)

Continued

Equipment, etc.	Article number	Note
Oil collecting vessel	-	The capacity of the vessel must be sufficient to take the complete amount of oil.
Oil dispenser	-	One example of oil dispenser can be found in section Type of lubrication in gearboxes on page 145 .
Lifting eye	3HAC16131-1	M12
Lifting eye	3HAC14457-4	M16
Fender washer	-	Outer diameter: minimum 26 mm, maximum 30 mm, hole diameter: 13 mm, thickness: 3 mm.
Lifting shackle	-	SA-10-8-NA1
Roundsling, 1.5 m	-	Length: 1.5 m. Lifting capacity: 2,000 kg.
Roundsling, 1 m	-	Length: 1 m, lifting capacity: 1,000 kg.
Lifting accessory (chain)	3HAC15556-1	Lifting instruction 3HAC15880-2 enclosed.
Rotation tool	3HAB7887-1	Used to rotate the motor pinion.
24 VDC power supply	-	Used to release the motor brakes.
Removal tool kit M12 and M14	3HAC057339-002	Used to push out the motor, if necessary. Always use removal tools in pairs. Size depending on motor type, see Type A vs type B motors on page 805 .
Guide pin, M16x150	3HAC13120-2	Always use guide pins in pairs.
Guide pin, M16x200	3HAC13120-3	Always use guide pins in pairs.
Guide pin, M12x150	3HAC13056-2	Always use guide pins in pairs.
Guide pin, M12x200	3HAC13056-3	Always use guide pins in pairs.
Aligning tool	3HAC046645-003	Used for aligning the gearbox against the frame, so that the play in the motor does not need to be adjusted.
Guide pin, M10x150	3HAC15521-2	Always use guide pins in pairs.
Lifting accessory, gearbox	3HAC046112-001	
Hydraulic cylinder	3HAC11731-1	To be used with the press and puller tools. See technical specifications in the user instructions for the press equipment.
Hydraulic pump 80 MPa	3HAC13086-1	To be used with the press and puller tools. See technical specifications in the user instructions for the press equipment.
Leak-down tester	-	
Calibration Pendulum toolkit	3HAC15716-1	Required if Calibration Pendulum is the valid calibration method for the robot.

Continues on next page

4.8.4 Replacing the axis-2 gearbox (IRB 6700 - 300/2.70, IRB 6700 - 245/3.00)

Continued

Equipment, etc.	Article number	Note
Calibration tool box, Axis Calibration	3HAC055412-001	Delivered as a set of calibration tools. Required if Axis Calibration is the valid calibration method for the robot.
Standard toolkit	-	Content is defined in section Standard toolkit on page 814 .

Consumables

Equipment, etc	Article number	Note
Grease	3HAC042536-001	Shell Gadus S2 Used to lubricate o-rings.
O-ring	3HAB3772-107	D=102x3 Used on motor flange.
O-ring ⁱ	3HAB3772-111 (circular profile) / 3HAC054692-002 (hexagon profile)	D=169.5x3 Used on motor cover.
O-ring	3HAB3772-144	D=309.3x3.1 Used on gearbox.
VK cover	3HAA2166-28	VK 28x7
Locking liquid (Loctite 2701)	-	

ⁱ The cross-section profile is either circular or hexagon. If only ordering the o-ring, order the same profile that is currently installed in the connection box.

Required documents

Document name	Document number	Note
<i>Technical reference manual - Lubrication in gearboxes</i>	3HAC042927-001	

Deciding calibration routine

Decide which calibration routine to be used, based on the information in the table. Depending on which routine is chosen, action might be required prior to beginning the repair work of the robot, see the table.

	Action	Note
1	Decide which calibration routine to use for calibrating the robot. <ul style="list-style-type: none"> Reference calibration. External cable packages (DressPack) and tools can stay fitted on the robot. Fine calibration. All external cable packages (DressPack) and tools must be removed from the robot. 	

Continues on next page

4 Repair

4.8.4 Replacing the axis-2 gearbox (IRB 6700 - 300/2.70, IRB 6700 - 245/3.00)

Continued

Action	Note
<p>If the robot is to be calibrated with reference calibration: Find previous reference values for the axis or create new reference values. These values are to be used after the repair procedure is completed, for calibration of the robot. If no previous reference values exist, and no new reference values can be created, then reference calibration is not possible.</p>	<p>Follow the instructions given in the reference calibration routine on the FlexPendant to create reference values. Creating new values requires possibility to move the robot. Read more about reference calibration for Axis Calibration in Reference calibration routine on page 782. Read more about reference calibration for Pendulum Calibration in <i>Operating manual - Calibration Pendulum</i>.</p>
<p>If the robot is to be calibrated with fine calibration: Remove all external cable packages (DressPack) and tools from the robot.</p>	

Removing the axis-2 gearbox

Use these procedures to remove the gearbox.

Follow the order of the separate procedures according to the order they are presented.



CAUTION

When performing these procedures, the cable harness will still be fitted or partly fitted to the robot. Use extreme caution not to cause any damage to the cable harness!

Preparations before replacing the axis-2 gearbox

	Action	Note
1	Decide which calibration routine to use, and take actions accordingly prior to beginning the repair procedure.	
2	 DANGER Turn off all: <ul style="list-style-type: none"> • electric power supply • hydraulic pressure supply • air pressure supply to the robot, before entering the safeguarded space.	
3	Begin draining the gearbox.	See Draining the axis-2 gearbox on page 155 .



Continues on next page

4.8.4 Replacing the axis-2 gearbox (IRB 6700 - 300/2.70, IRB 6700 - 245/3.00)

Continued

Unloading the balancing device springs with the robot and locking position with the Distance tool

Use this procedure to unload the balancing device with the help of the robot, and lock the balancing device springs in a compressed position, using the Distance tool (3HAC030662-001).

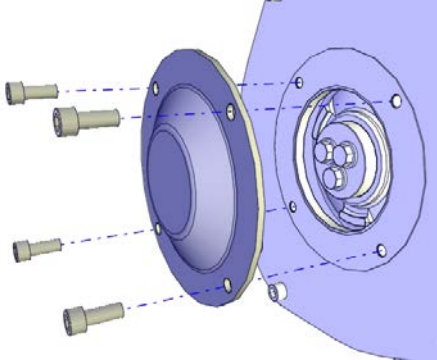

	Action	Note
1	<p> DANGER</p> <p>Do not use the Distance tool (3HAC030662-001) to unload or restore the pressure of the balancing device springs! This tool is only used to lock the spring unit in a compressed position, after axis-2 has been jogged to -30° or $+30^\circ$. Fitting and removal of the tool shall only be done with axis-2 in this position!</p> <p>To unload or restore a new balancing device or if the spring unit of the balancing device cannot be compressed by jogging the robot, only use the Hydraulic press equipment, balancing device (3HAC074411-001).</p>	
2	<p>Jog axis-2 to:</p> <ul style="list-style-type: none"> • -30° or $+30^\circ$ 	<p>This is done in order to compress the balancing device springs inside the balancing device before fitting the Distance tool.</p>
3	<p> DANGER</p> <p>Turn off all:</p> <ul style="list-style-type: none"> • electric power supply • hydraulic pressure supply • air pressure supply <p>to the robot, before entering the robot working area.</p>	
4	<p>Remove the cover plate on the back of the balancing device.</p> <p> DANGER</p> <p>DO NOT remove any other screws than the rear cover attachment screws.</p>	 <p>xx1300000554</p>

Continues on next page

4 Repair

4.8.4 Replacing the axis-2 gearbox (IRB 6700 - 300/2.70, IRB 6700 - 245/3.00)

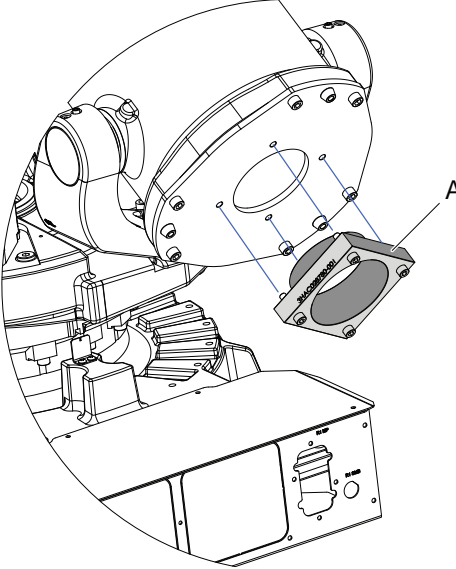
Continued

	Action	Note
5	<p>Fit the Distance tool on the back of the balancing device using the four screws.</p> <p> DANGER</p> <p>Use caution when tightening the screws. The threads in the cover can be damaged if more tightening torque than 45 Nm is used, risking that the Distance tool is not properly fitted.</p>	<p>Tightening torque: 45 Nm Attachment screws: M10 quality 12.9 (4 pcs)</p>  <p>xx0800000480</p> <p>A Distance tool: 3HAC030662-001</p>
6	Turn the power on temporary.	
7	Jog axis-2 to the calibration position. The balancing device is now unloaded.	This is done to compress the balancing device springs, making it possible to remove the front shaft of the balancing device.
8	Let the Distance tool stay fitted during the continued procedure.	
9	<p> DANGER</p> <p>Turn off all:</p> <ul style="list-style-type: none"> • electric power supply • hydraulic pressure supply • air pressure supply <p>to the robot, before entering the robot working area.</p>	

Attaching lifting accessory to the balancing device

	Action	Note
1	<p> CAUTION</p> <p>The weight of the balancing device (excluding cradle) is</p> <p>140 kg (IRB 6700 -235/2.65, -205/2.80, -175/3.05, -150/3.20, -200/2.60, -155/2.85)</p> <p>185 kg (IRB 6700 -300/2.70, -245/3.00)</p> <p>All lifting accessories used must be sized accordingly.</p>	

Continues on next page

4.8.4 Replacing the axis-2 gearbox (IRB 6700 - 300/2.70, IRB 6700 - 245/3.00)

Continued

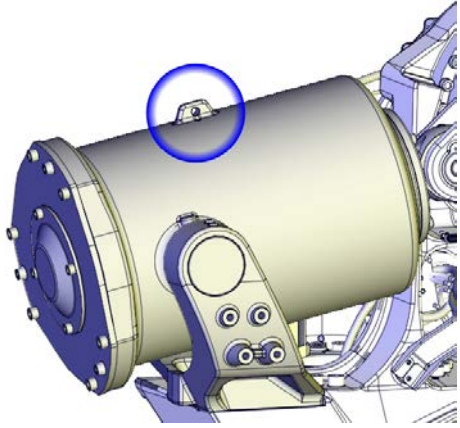
	Action	Note
2	Fit a lifting shackle to the balancing device.	Lifting shackle: SA-10-8-NA1  xx130000661
3	Fit the lifting accessory to the shackle and raise to unload the weight.	Lifting accessory (chain): 3HAC15556-1

Removing the shaft in the front (link ear)

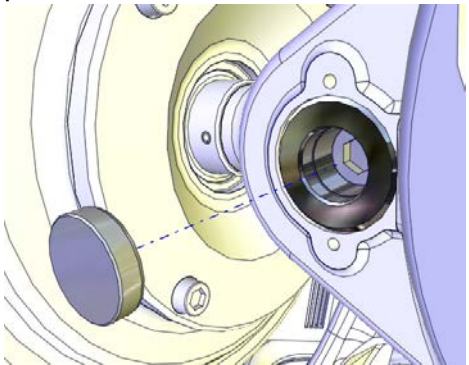
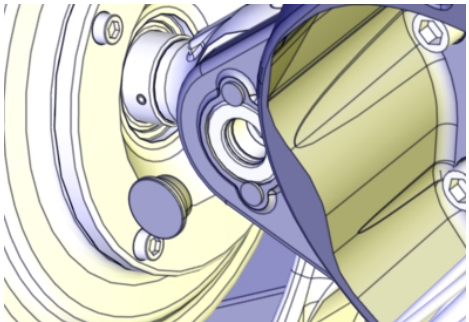

	Action	Note
1	Remove the protection plug or VK cover at the link ear (depends on shaft version).	It is possible to drive a screwdriver (or similar) through the VK cover, as close as possible to the center of the VK cover and pull it out.  xx1200001278  xx1900002311

Continues on next page

4 Repair

4.8.4 Replacing the axis-2 gearbox (IRB 6700 - 300/2.70, IRB 6700 - 245/3.00)

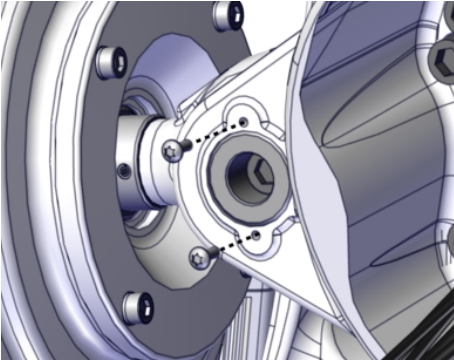
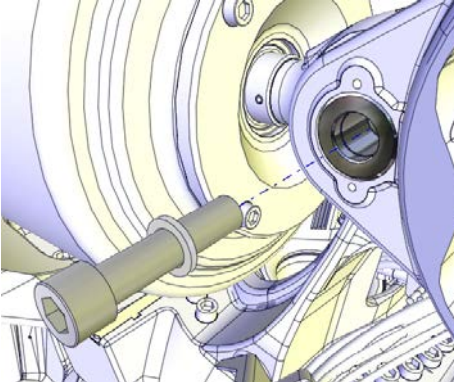
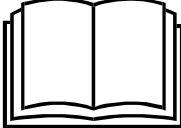
Continued

	Action	Note
2	Remove the two screws.	 <p>xx1900002146</p>
3	Unscrew the attachment screw and washer.	 <p>xx1200001279</p> <ul style="list-style-type: none"> • M16x70 quality steel 8.8-A3F
4	<p>Pull the shaft out using the dismantle and mounting tool, according to user instructions enclosed with the equipment.</p>  <p>xx0900000813</p> <p>Go to the user instructions enclosed with the press tool.</p> <p> DANGER</p> <p>Handling the tool incorrectly will cause serious injury.</p> <p>Read and follow enclosed user instructions for the tool.</p>	<p>Dismantle and mounting tool: 3HAC028920-001</p> <p>User instructions are enclosed with the tool.</p>



Continues on next page

4.8.4 Replacing the axis-2 gearbox (IRB 6700 - 300/2.70, IRB 6700 - 245/3.00)

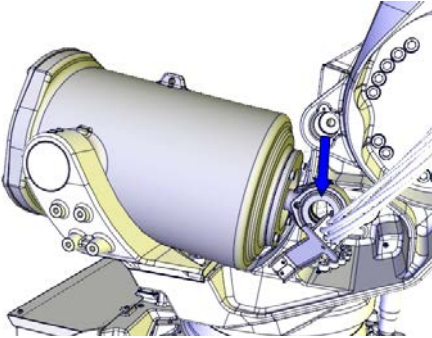
Continued

	Action	Note
5	Put down the balancing device and let it rest on the frame.	 <p>xx1200001281</p>

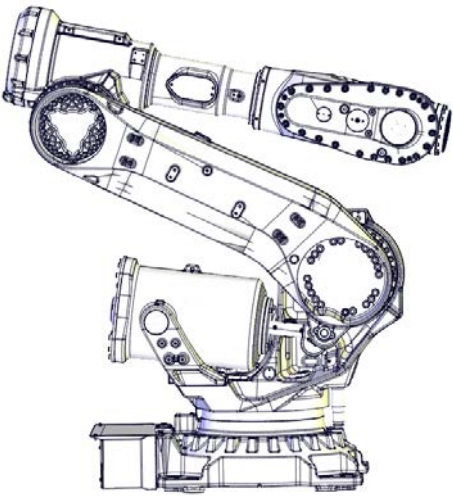
Robot position

	Action	Note
1	 Note When jogging the axis-2 into position check that the balancing device ear and the ear on the lower arm is not colliding!	
2	Jog the robot into position: <ul style="list-style-type: none"> • Axis 1: position the axis 1 to be able to put down the arm system after removal • Axis 2: -60° • Axis 3: +70° (approximately) • Axis 4: +90° • Axis 5: 0° (-90° if DressPack is installed) • Axis 6: 0° (+90° if DressPack is installed) 	 <p>xx1200001250</p>
3	 DANGER Turn off all: <ul style="list-style-type: none"> • electric power supply • hydraulic pressure supply • air pressure supply to the robot, before entering the safe-guarded space.	

Continues on next page

4 Repair

4.8.4 Replacing the axis-2 gearbox (IRB 6700 - 300/2.70, IRB 6700 - 245/3.00)

Continued

Attaching lifting accessories to the lower and upper arm



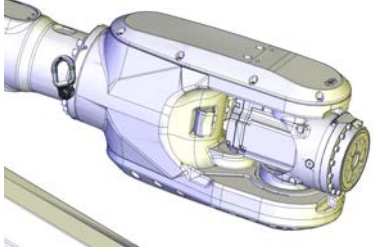
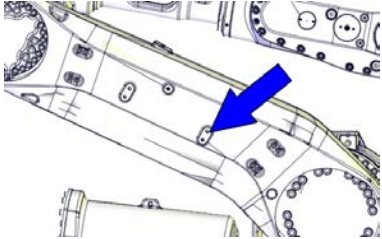
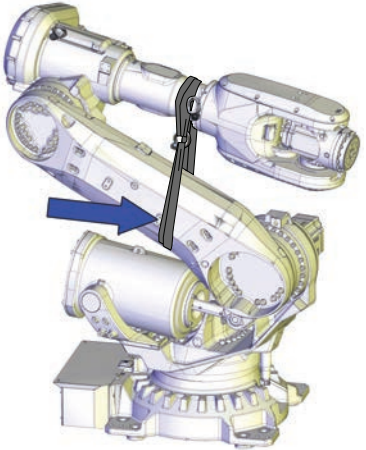

Use this procedure to attach the lifting accessories.

	Action	Note
1	 CAUTION The lower and upper arms together weigh (according to variants) 650 kg. All lifting accessories used must be sized accordingly!	
2	Fit a lifting eye to the wrist.	Lifting eye: 3HAC16131-1  <small>xx1400002106</small>
3	In order to secure the roundsling from gliding when lifting: <ul style="list-style-type: none"> • <i>With no DressPack cable package installed:</i> Insert a M12x50 securing screw, not more than 10-15 mm, into the screw hole shown in the figure. • <i>With DressPack cable package installed:</i> Use the ball joint housing in the same way. 	 <small>xx1200001251</small>
4	Run a roundsling around the lower arm, place it accordingly: <ul style="list-style-type: none"> • <i>With no DressPack cable package installed:</i> Place the roundsling beneath the securing screw. • <i>With DressPack cable package installed:</i> Place the roundsling beneath the ball joint housing on the outside of the lower arm. 	Roundsling, 2.5 m: Length: 2.5 m. Lifting capacity: 2,000 kg.  <small>xx1400002105</small>
5	Run the roundsling up and over the upper arm.	

Continues on next page

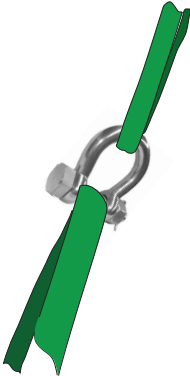
4.8.4 Replacing the axis-2 gearbox (IRB 6700 - 300/2.70, IRB 6700 - 245/3.00)

Continued

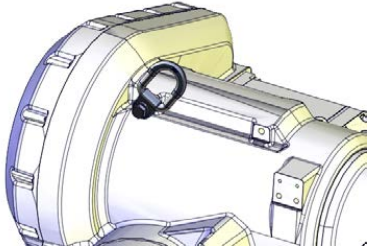
	Action	Note
6	<p>Connect both ends of the roundsling with a shackle.</p>	 <p>xx140000729</p>
7	<p>Stretch the roundsling between the upper and the lower arm by slowly jogging the axis-3.</p> <p> Note</p> <p>Make sure the roundsling is stretched, in order to carry the weight of the lower arm.</p>	
8	<p> DANGER</p> <p>Turn off all:</p> <ul style="list-style-type: none"> • electric power supply • hydraulic pressure supply • air pressure supply <p>to the robot, before entering the robot working area.</p>	
9	<p>Fit a lifting eye in the arm house, with a fender washer underneath.</p>  <p>xx1400002196</p>	<p>Lifting eye: 3HAC16131-1</p> <p>Fender washer: Outer diameter: minimum 26 mm, maximum 30 mm, hole diameter: 13 mm, thickness: 3 mm.</p>  <p>xx1200001134</p>

Continues on next page

4 Repair

4.8.4 Replacing the axis-2 gearbox (IRB 6700 - 300/2.70, IRB 6700 - 245/3.00)

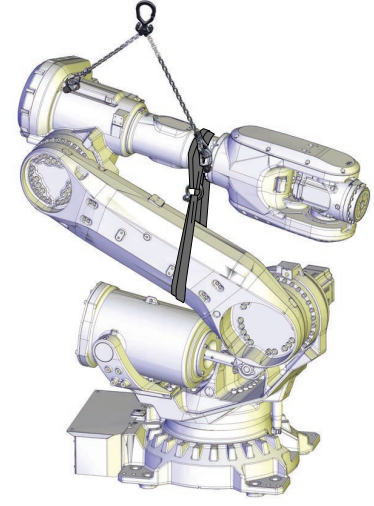

Continued

	Action	Note
10	Attach the Lifting accessory (chain) to an overhead crane (or similar), then to the lifting eye in the arm house and to the lifting eye in the wrist.	Lifting accessory (chain): 3HAC15556-1  xx1400002104
11	Raise the overhead crane to stretch the chains and roundslings. Verify that the roundslings between the wrist and the lower arm is stretched.	
12	To release the brake, connect the 24 VDC power supply. Connect to connector R2.MP2, axis-2 motor: <ul style="list-style-type: none">• + = pin 2• - = pin 5	

Continues on next page

Loosening the cable brackets

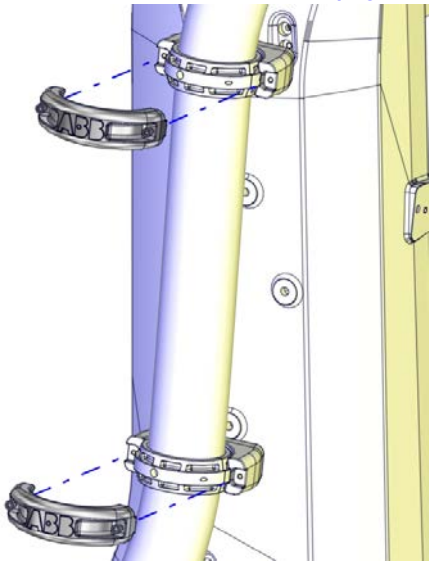
Use this procedure to loosen required cable brackets.

	Action	Note
1	<p>If robot is equipped with DressPack:</p> <ul style="list-style-type: none"> Open the two ball joint housings from the lower arm and lift away the cabling from the ball joint housings. 	<p>How to remove the DressPack cable package is described in more detail in the product manual "IRB 6700 DressPack". For article number see References on page 10.</p>  <p>xx140000195</p>
2	<p>Unscrew the attachment screws that secure the axis-2 lower arm metal clamp and the axis-3 lower arm metal clamp located on the inside of the lower arm by removing the attachment screws.</p> <p> Note</p> <p>The screws are reached from outside the lower arm.</p>	 <p>xx1300000540</p>

Continues on next page

4 Repair

4.8.4 Replacing the axis-2 gearbox (IRB 6700 - 300/2.70, IRB 6700 - 245/3.00)

Continued

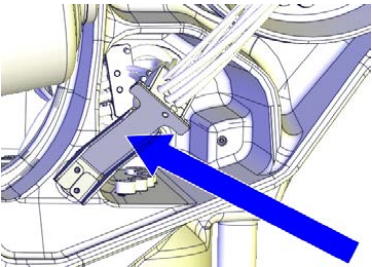
	Action	Note
3	Unscrew the attachment screws of the cable bracket on the frame and let it hang loose.	 xx1200001283

Fitting guide pins to the lower arm

Use this procedure to prepare the removal of the lower arm.

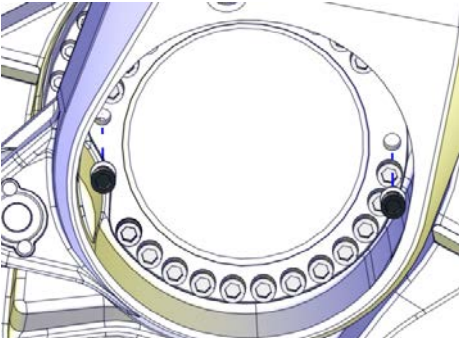
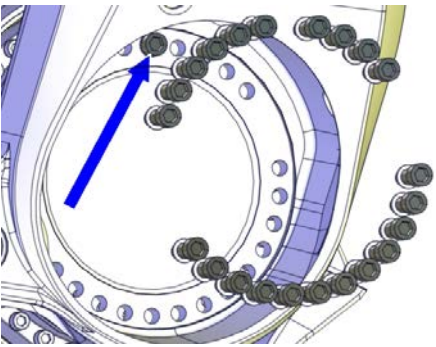
	Action	Note
1	Remove two attachment screws in opposite holes and replace them with guide pins.  Tip Lubricate the guide pins with some grease to make the lower arm slide better.	Guide pin, M16x150: 3HAC13120-2 Guide pin, M16x200: 3HAC13120-3 Always use guide pins in pairs.  xx1400002181
2	Remove all but one of the remaining attachment screws that secure the lower arm to the axis-2 gearbox.	 xx1400002182



Continues on next page

4.8.4 Replacing the axis-2 gearbox (IRB 6700 - 300/2.70, IRB 6700 - 245/3.00)

Continued

Removing and lifting away the lower and upper arms un-separated

Use this procedure to remove and lift away the lower and upper arm un-separated.

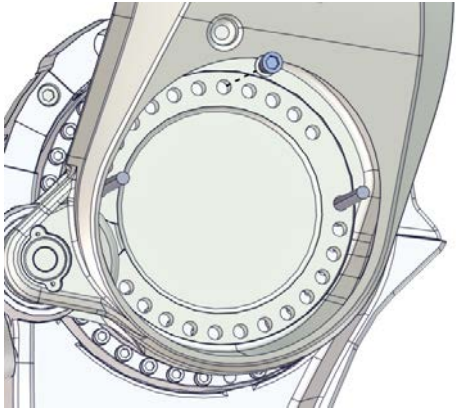
	Action	Note
1	<p>Put two pallets on the floor, in front of the position of the mechanical stop.</p> <p> Note</p> <p>Using the method to replace the gearbox with cable harness and DressPack fitted, is only a recommendation. If it is not possible to put the arm system close enough to the robot and keep the cable harness partly fitted, it is necessary to remove the cable harness and DressPack in base and frame first.</p>	
2	<p> CAUTION</p> <p>The lower and upper arms together weigh 650 kg. All lifting accessories used must be sized accordingly!</p>	
3	<p>Remove the remaining screw and lift away the lower and upper arm together.</p> <p>Let the cabling run in the lower arm. Make sure not to stretch any cabling!</p> <p> Note</p> <p>Two persons required. One person to operate the overhead crane and one person to handle the arm system.</p>	 <p>xx170000442</p>
4	<p>Use a piece of wood or similar as a support under the arm house when the arm system is put down on the pallets.</p> <p>This is done in order not to damage any parts of the cable harness and DressPack.</p>	

Disconnecting the axis-2 motor cables

Use this procedure to disconnect the motor cables.

	Action	Note
1	<p> DANGER</p> <p>Make sure that all supplies for electrical power, hydraulic pressure, and air pressure are turned off.</p>	

Continues on next page

4 Repair

4.8.4 Replacing the axis-2 gearbox (IRB 6700 - 300/2.70, IRB 6700 - 245/3.00)

Continued

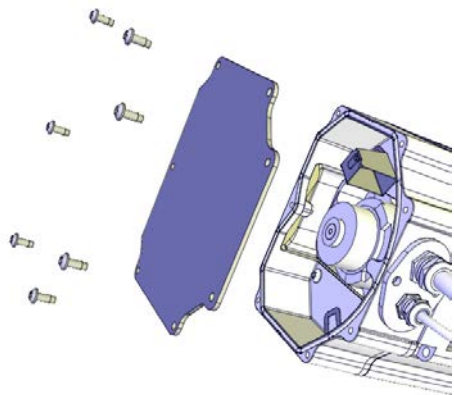
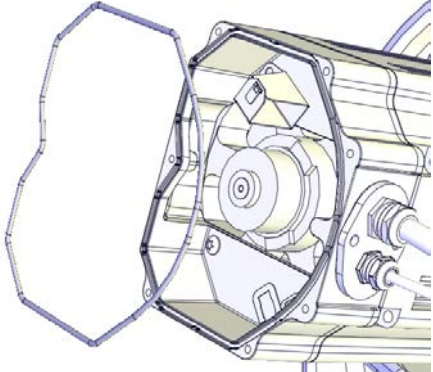
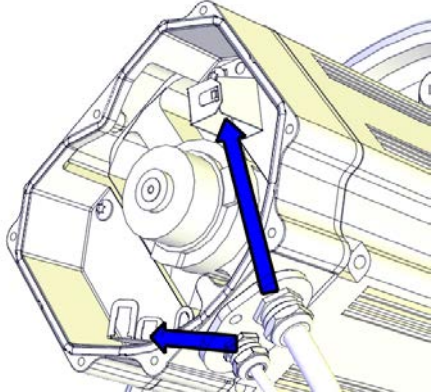
	Action	Note
2	Unscrew the attachment screws and washers and remove the motor cover.	 xx1200001135
3	Make sure the o-ring is present.	 xx1200001070
4	Disconnect the motor cables.	 xx1200001066

Continues on next page

4.8.4 Replacing the axis-2 gearbox (IRB 6700 - 300/2.70, IRB 6700 - 245/3.00)

Continued

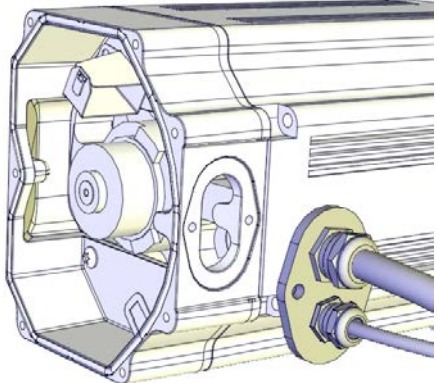
	Action	Note
5	<p>Remove the cable gland cover. Make sure the gasket is not damaged.</p> <p> Tip</p> <p>Make a note in which direction the cable gland hole is facing, if the motor will be removed too. The motor shall be refitted in the same position.</p>	 <p>xx1200001067</p>
6	Use caution and pull out the motor cables.	

Removing the axis-2 motor

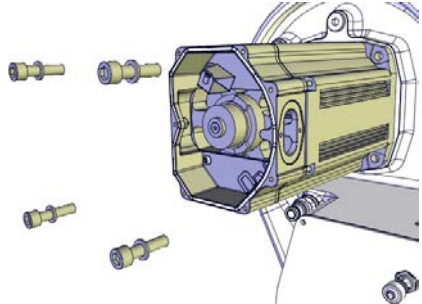

	Action	Note
1	Before removing the motor, make sure that the axis-2 gearbox is completely drained.	
2	<p> DANGER</p> <p>When releasing the holding brakes of the motor, the lower arm will be movable and may fall down if not secured. Verify that the lower arm is secured as previously described, before continuing.</p>	
3	<p>To release the brake, connect the 24 VDC power supply.</p> <p>Connect to connector R2.MP2, axis-2 motor:</p> <ul style="list-style-type: none"> • + = pin 2 • - = pin 5 	
4	<p>Remove the attachment screws.</p> <p>Use a bits extender in order to reach the screws.</p>	<p>Bits extender: 3HAC12342-1</p>  <p>xx1200001117</p>

Continues on next page

4 Repair

4.8.4 Replacing the axis-2 gearbox (IRB 6700 - 300/2.70, IRB 6700 - 245/3.00)

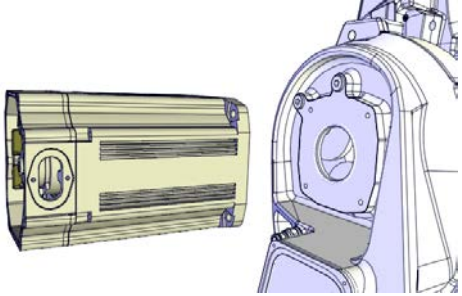

Continued

	Action	Note
5	<p>Fit guide pins in opposite holes.</p> <p> Tip</p> <p>Lubricate the guide pins with some grease to make the motor slide better.</p>	<p>Guide pin, M10x150: 3HAC15521-2</p> <p>Always use guide pins in pairs.</p>
6	<p> CAUTION</p> <p>Whenever parting/mating motor and gearbox, the gears may be damaged if excessive force is used.</p>	
7	<p>If required, press the motor out of its position by using the removal tool in opposite holes of the motor.</p>	<p>Removal tool kit M12 and M14: 3HAC057339-002</p> <p>Removal tool kit M12 and M14: 3HAC057339-002</p> <p>Depending on motor type A or B, see Identifying the motor by article number on page 805</p> <p>Always use removal tools in pairs.</p>
8	<p>Disconnect the 24 VDC power supply.</p>	
9	<p> CAUTION</p> <p>The motor weighs 28 kg.</p> <p>All lifting accessories used must be sized accordingly.</p>	
10	<p>Carefully lift the motor out on the guide pins, in order to get the pinion away from the gear and let it rest on the guide pins.</p>	
11	<p>Fasten the lifting accessory. Attach the lifting chain to the accessory and an overhead crane.</p>	<p>Lifting accessory, motor: 3HAC15534-1</p> <p>Lifting accessory (chain): 3HAC15556-1</p>
12	<p>Remove the motor by sliding it out on the guide pins and lift it off.</p>	<p>Make sure the pinion is not damaged.</p>  <p>xx1200001118</p>

Continues on next page

Removing the axis-2 gearbox

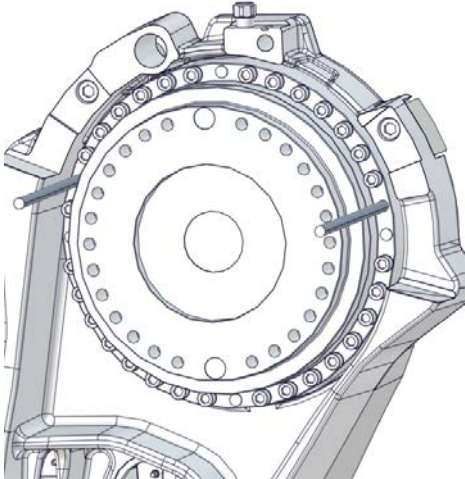
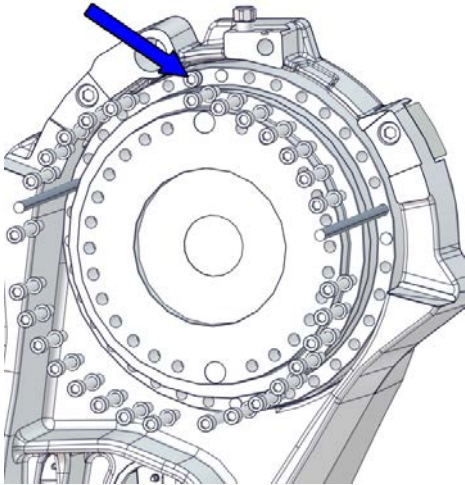
Use the procedure to remove gearbox.

	Action	Note
1	<p>Remove two attachment screws in opposite holes and replace them with guide pins.</p> <p> Tip</p> <p>Lubricate the guide pins with some grease to make the gearbox slide better.</p>	<p>Guide pin, M12x150: 3HAC13056-2 Guide pin, M12x200: 3HAC13056-3 Always use guide pins in pairs.</p>  <p>xx170000443</p>
2	<p>Leave one of the upper attachment screws and remove the rest. The remaining screw is used to prevent the gearbox from falling down.</p>	 <p>xx170000444</p>
3	<p> CAUTION</p> <p>The gearbox weighs 110 kg. All lifting accessories used must be sized accordingly!</p>	

Continues on next page

4 Repair

4.8.4 Replacing the axis-2 gearbox (IRB 6700 - 300/2.70, IRB 6700 - 245/3.00)

Continued

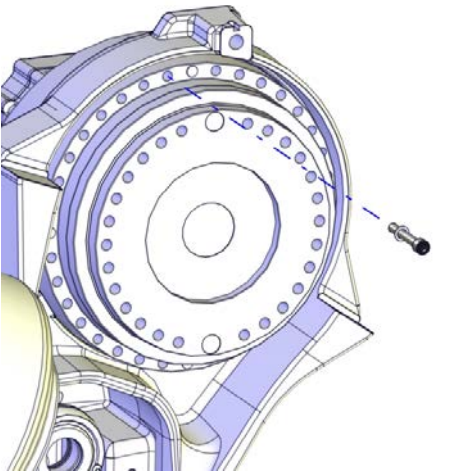
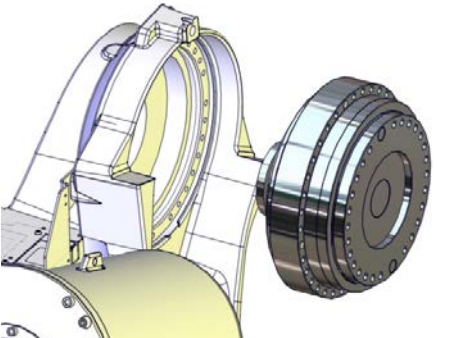
	Action	Note
4	Remove the remaining screw left in the gearbox.	 <p>xx1400002185</p>
5	Use two fully threaded attachment screws (M12) as removal tools to press the gearbox out of position.	
6	Attach the lifting accessory to the gearbox.	Lifting accessory, gearbox: 3HAC046112-001
7	Let the gearbox slide out on the guide pins.	
8	Remove the gearbox.	 <p>xx1400002186</p>

Refitting the axis-2 gearbox

Use these procedures to refit the gearbox.

Follow the order of the separate procedures according to the order they are presented.





CAUTION

When performing these procedures, the cable harness will still be fitted or partly fitted to the robot. Use the utmost caution not to cause any damage to the cable harness!

Continues on next page

Refitting the gearbox

Use this procedure to refit the gearbox.

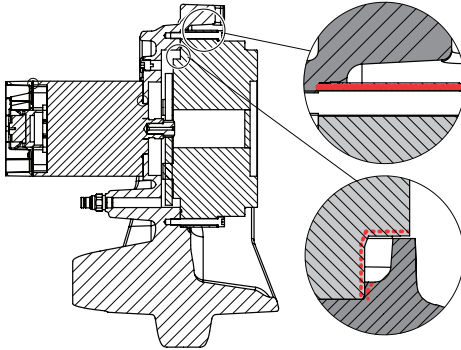
	Action	Note
1	 CAUTION The gearbox weighs according to variant 110 kg. All lifting accessories used must be sized accordingly!	
2	Apply the lifting accessory to the gearbox.	Lifting accessory, gearbox: 3HAC046112-001
3	Use caution and lift the gearbox so that it rests on its side.	
4	Remove the o-ring and wipe it clean.  Note This must also be done on a new spare part!	
5	Wipe clean the contact surfaces from any contamination.  Note Also wipe clean the o-ring groove.	
6	Check the condition of the o-ring. Replace if damaged.	
7	Lubricate the o-ring with some grease, for a better fitting in the groove.	
8	Fit the o-ring in the groove.	
9	<i>Foundry Plus:</i> Apply Mercasol on the surfaces shown in the figure.	 <p>xx140000374</p>

Continues on next page

4 Repair

4.8.4 Replacing the axis-2 gearbox (IRB 6700 - 300/2.70, IRB 6700 - 245/3.00)

Continued

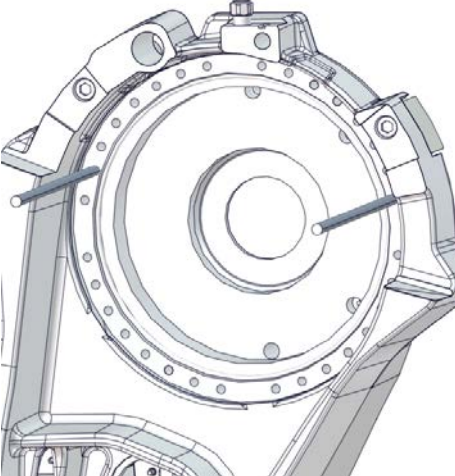
	Action	Note
10	<p>Fit two guide pins in opposite holes (M12).</p> <p> Tip</p> <p>Lubricate the guide pins with some grease to make the gearbox slide better.</p>	<p>Guide pin, M12x150: 3HAC13056-2 Guide pin, M12x200: 3HAC13056-3 Always use guide pins in pairs.</p>  <p>xx170000445</p>
11	Lift the gearbox and let it rest on the guide pins.	
12	Slide the gearbox into position.	

Continues on next page

4.8.4 Replacing the axis-2 gearbox (IRB 6700 - 300/2.70, IRB 6700 - 245/3.00)

Continued

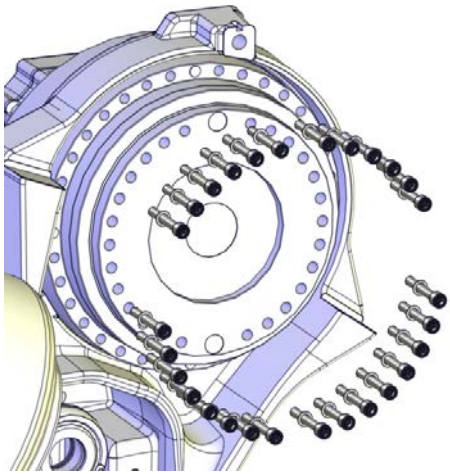
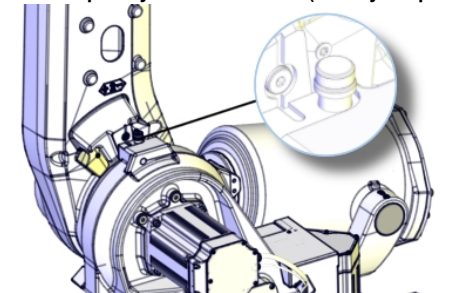
	Action	Note
13	Fit the attachment screws now accessible.	 <p>xx1400002188</p> <p>Screw dimension: There are two versions of the robot frame. Depending on which frame the robot is equipped with, the depth of the screw holes in the frame, used for the axis-2 gearbox, differ. The frame that is configured for Axis Calibration, has a calibration pin and bushing as shown in the figure. For this frame, screws with dimension M12x90 should be used. For a frame without the calibration pin and bushing, screws with dimension M12x80 should be used..</p> <p>Screw quality: 12.9 Gleitmo (totally 32 pcs)</p>  <p>xx1500002118</p>
14	Remove the lifting accessory.	
15	Remove the guide pins and fit the remaining attachment screws.	
16	Secure the gearbox with its attachment screws.	Tightening torque: 120 Nm.

Preparations prior to refitting motor



	Action	Note
1	 <p>DANGER</p> <p>Make sure that all supplies for electrical power, hydraulic pressure, and air pressure are turned off.</p>	

Continues on next page

4 Repair

4.8.4 Replacing the axis-2 gearbox (IRB 6700 - 300/2.70, IRB 6700 - 245/3.00)

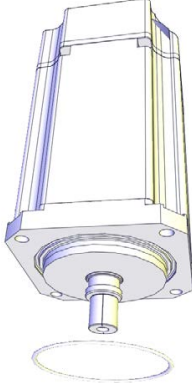
Continued

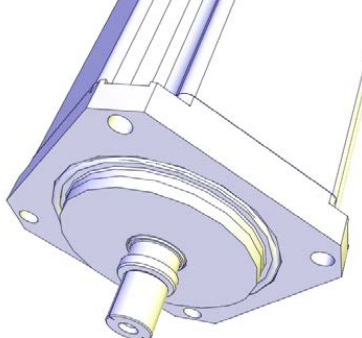
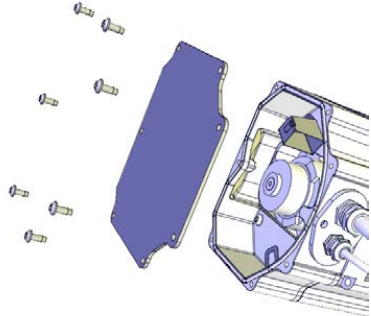
	Action	Note
2	<p>Remove any old paint residues or other contamination from the contact surfaces on both the motor and the mating parts. Wipe clean the contact surfaces and the o-ring groove.</p>	
3	<p>Fit a new o-ring.</p>	 <p>xx1200001019</p>
4	<p>Make sure the o-ring is seated in the groove.</p> <p> Tip Lubricate the o-ring with some grease for a better fitting in the groove.</p>	 <p>xx1200001020</p>
5	<p>If the motor is a new spare part, remove the cover.</p>	 <p>xx1200001135</p>





Securing the axis-2 motor

	Action	Note
1	<p>Fit guide pins in opposite holes.</p>	<p>Guide pin, M10x150: 3HAC15521-2 Always use guide pins in pairs.</p>

Continues on next page

4.8.4 Replacing the axis-2 gearbox (IRB 6700 - 300/2.70, IRB 6700 - 245/3.00)

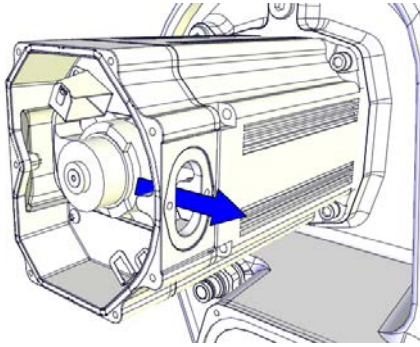
Continued

	Action	Note
2	 CAUTION The motor weighs 28 kg. All lifting accessories used must be sized accordingly.	
3	Apply the lifting accessory.	Lifting accessory, motor: 3HAC15534-1 Lifting accessory (chain): 3HAC15556-1
4	 Note Make sure the cable gland opening is turned the correct way.	 xx1200001120
5	Lift the motor and put it on the guide pins as close as possible to its final position without pushing the motor pinion into the gear.	
6	Remove the lifting accessory and allow the motor to rest on the guide pins.	
7	Apply the rotation tool and use it to rotate the pinion when mating it into the gear.	Rotation tool: 3HAB7887-1
8	To release the brakes, connect the 24 VDC power supply. Connect to connector R2.MP2, axis-2 motor: <ul style="list-style-type: none"> • + = pin 2 • - = pin 5 	
9	 CAUTION Whenever parting/mating motor and gearbox, the gears may be damaged if excessive force is used.	
10	Use caution and fit the motor in its final position while at the same time rotating the motor pinion slightly using the rotation tool. <ul style="list-style-type: none"> • Make sure that the motor pinion is properly mated to the gear of the gearbox. • Make sure that the motor pinion does not get damaged. • Make sure that the direction of the cable exit is facing the correct way. 	
11	Fit two of the attachment screws and washers.	Screws: M10x30 Steel 12.9 Gle 603+Geo500

Continues on next page

4 Repair

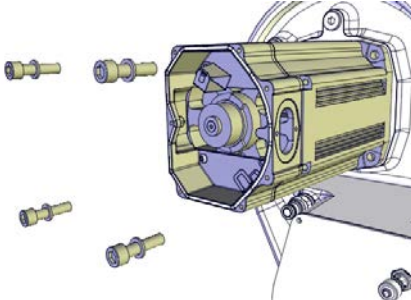

4.8.4 Replacing the axis-2 gearbox (IRB 6700 - 300/2.70, IRB 6700 - 245/3.00)

Continued

	Action	Note
12	Remove the guide pins and replace with the remaining attachment screws.	
13	Secure the motor with its attachment screws and washers. Use a bits extender in order to reach the screws.	Bits extender: 3HAC12342-1 Tightening torque: 50 Nm. Screw dimension: M10x30 Steel 12.9 Gle 603+Geo500 (4 pcs)  xx1200001117
14	Perform a leak-down test.	See Performing a leak-down test on page 186 .

Lifting back and refitting the lower and upper arm

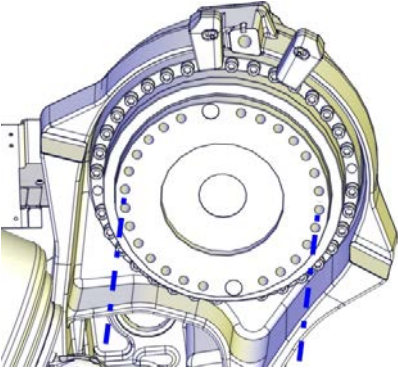

Use this procedure to lift back and refit the lower and upper arm un-separated.

	Action	Note
1	Connect the 24 VDC power supply to the axis-2 motor to release the brakes of the motor.	
2	Fit the rotation tool, if not already fitted.	Rotation tool: 3HAB7887-1
3	Fit two guide pins in opposite holes in the axis-2 gearbox.  Tip Lubricate the guide pins with some grease to make the lower arm slide better.	Guide pin, M16x150: 3HAC13120-2 Always use guide pins in pairs.  xx1400002189
4	 CAUTION The lower and upper arms together weigh 650 kg. All lifting accessories used must be sized accordingly!	
5	Apply the lifting accessories, if not already fitted.	

Continues on next page

4.8.4 Replacing the axis-2 gearbox (IRB 6700 - 300/2.70, IRB 6700 - 245/3.00)

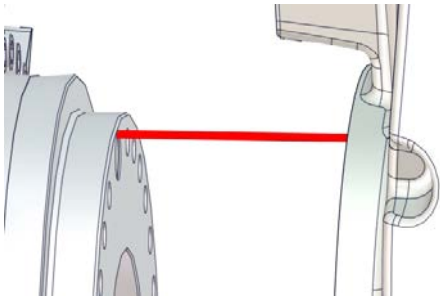
Continued

	Action	Note
6	Lift the lower and upper arm. Make sure: <ul style="list-style-type: none"> not to stretch any of the cables that the arm package is level when lifted. 	
7	Align the lower arm with the gearbox in height. Match the upper edge of the gearbox with the corresponding edge inside the lower arm cavity.  Tip This operation is best performed by two persons working together.	 xx1700000692
8	Rotate the gear to match the hole pattern in the lower arm, using the rotation tool.  Note Some of the screw holes in the gear are unused.	Rotation tool: 3HAB7887-1  xx1300000819
9	Slide the lower arm onto the guide pins, when the hole pattern is matched and in the correct position for all screws.	
10	Slide the lower arm on to the guide pins.	
11	Use caution and move the arms into position at the axis-2 gearbox on the guide pins. Rotate the axis-2 gearbox until the hole pattern is matching the holes in the lower arm.	
12	Fit one attachment screw in one of the upper holes using it for security and lower the lifting accessory a little.	

Continues on next page



4 Repair

4.8.4 Replacing the axis-2 gearbox (IRB 6700 - 300/2.70, IRB 6700 - 245/3.00)

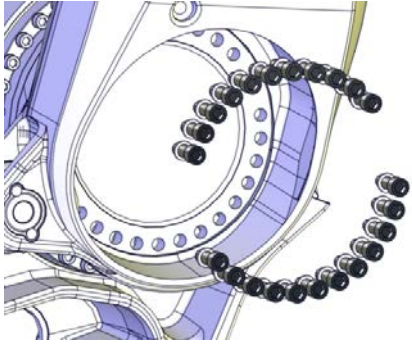
Continued

	Action	Note
13	Fit all now accessible attachment screws.	 <p>xx1400002190</p>
14	Remove the two guide pins and fit the remaining attachment screws.	
15	Secure the lower arm to the axis-2 gearbox with its attachment screws.	Tightening torque M16: 300 Nm.
16	Disconnect the 24 VDC power supply.	
17	Remove the lifting accessories.	

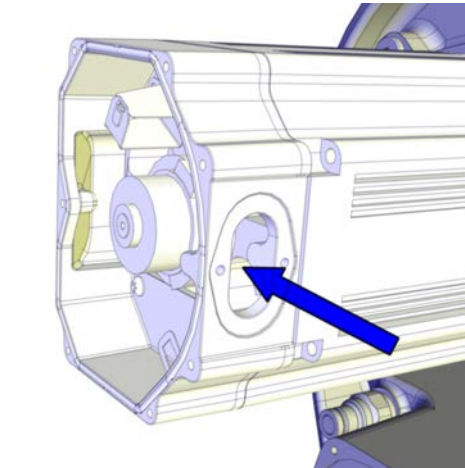

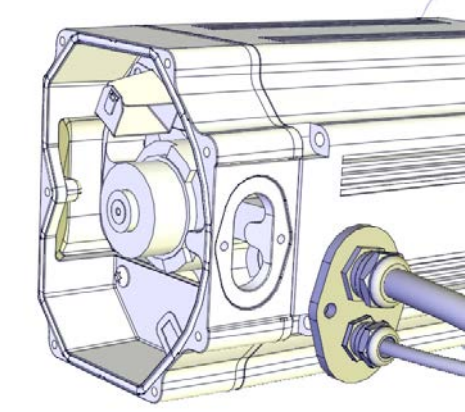

Connecting the axis-2 motor cables

	Action	Note
1	Push the motor cables through the cable gland opening.	 <p>xx1300000738</p>
2	Refit the cable gland cover.  Note Replace the gasket if damaged.	 <p>xx1200001067</p>

Continues on next page

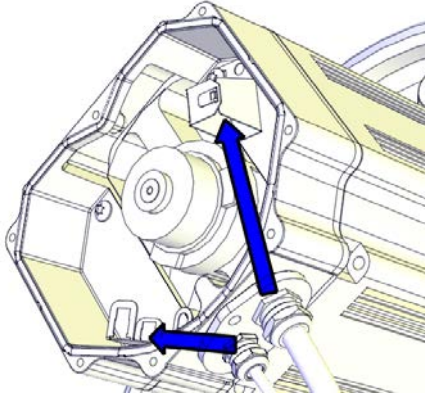
4.8.4 Replacing the axis-2 gearbox (IRB 6700 - 300/2.70, IRB 6700 - 245/3.00)

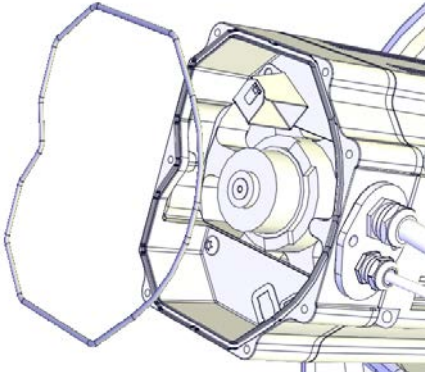
Continued



	Action	Note
3	<p>Connect the motor cables. Connect in accordance with the markings on the connectors.</p>	 <p>xx1200001066</p>
4	<p>Inspect the o-ring.</p> <p> Note Replace if damaged.</p>	<p>O-ring, axis-1: 3HAB3772-111 (circular profile) / 3HAC054692-002 (hexagon profile) O-ring, axis-2: 3HAB3772-111 (circular profile) / 3HAC054692-002 (hexagon profile) O-ring, axis-3: 3HAB3772-111 (circular profile) / 3HAC054692-002 (hexagon profile) O-ring, axis-4: 3HAB3772-110 (circular profile) / 3HAC054692-001 (hexagon profile)</p>  <p>xx1200001070</p>
5	<p>Wipe clean o-ring and o-ring groove.</p>	
6	<p>Refit the o-ring.</p> <p> Tip Lubricate the o-ring with some grease for a better fitting in the groove.</p>	
7	<p> CAUTION When fitting the motor cover, make sure that none of the cables inside will be damaged.</p>	

Continues on next page

4 Repair

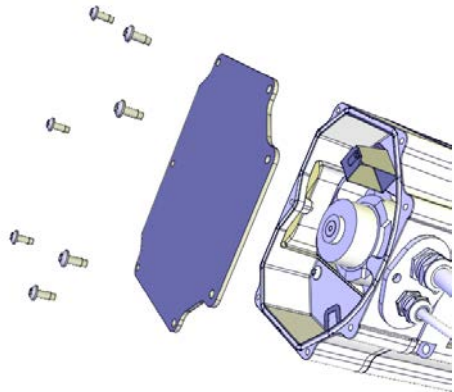

4.8.4 Replacing the axis-2 gearbox (IRB 6700 - 300/2.70, IRB 6700 - 245/3.00)

Continued

	Action	Note
8	<p>Refit the motor cover with its attachment screws.</p> <p> Note</p> <p>Do not reuse the self-threading attachment screws. Replace with standard attachment screws or the threads will be damaged.</p> <p> Note</p> <p>Make sure the o-ring is undamaged and properly fitted.</p>	<p>Attachment screws: M5x12 8.8 (7 pcs)</p>  <p>xx1200001135</p>
9	<p>Make sure that the covers are tightly sealed.</p>	

Refitting the cabling

Use this procedure to refit the cabling.

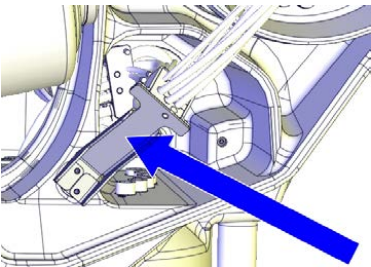
	Action	Note
1	<p>Use caution and push the cable harness into the lower arm.</p>	
2	<p>Refit the <i>axis-2 lower arm metal clamp</i> and the <i>axis-3 lower arm metal clamp</i> located on the inside of the lower arm.</p> <p> Note</p> <p>The screws are reached from the outside of the lower arm!</p>	 <p>xx1200001282</p>
3	<p>Refit the cable bracket on the frame.</p>	 <p>xx1200001283</p>

Continues on next page

4.8.4 Replacing the axis-2 gearbox (IRB 6700 - 300/2.70, IRB 6700 - 245/3.00)

Continued

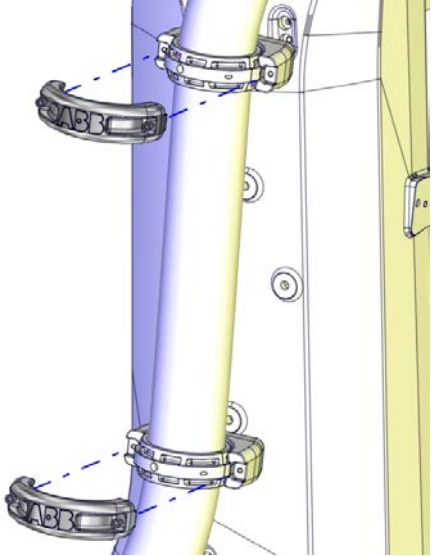
	Action	Note
4	If robot is equipped with DressPack. <ul style="list-style-type: none"> Place the cabling in the two ball joint housings on the lower arm and close the ball joint housings. 	How to refit the DressPack is described in the product manual "IRB 6700 DressPack". For article number see References on page 10 .  <p>xx140000195</p>

Refitting the front shaft of the balancing device



	Action	Note
1	Turn the power to the robot on temporarily.	
2	Use caution and jog the robot to the calibration position (if not already done).	
3	 <p>DANGER</p> Turn off all: <ul style="list-style-type: none"> electric power supply hydraulic pressure supply air pressure supply to the robot, before entering the robot working area.	
4	Apply the lifting accessory to the balancing device (if not already done).	Lifting shackle: SA-10-8-NA1 Lifting accessory (chain): 3HAC15556-1
5	Remove all residue of Loctite in the screw hole of the shaft.	
6	Wipe all contact surfaces inside the recess clean from contamination.	

Continues on next page

4 Repair

4.8.4 Replacing the axis-2 gearbox (IRB 6700 - 300/2.70, IRB 6700 - 245/3.00)

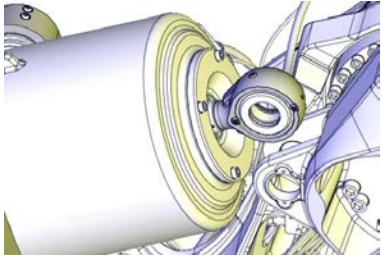
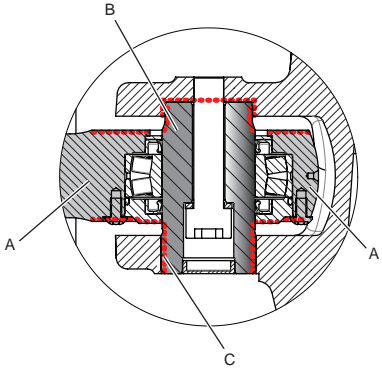

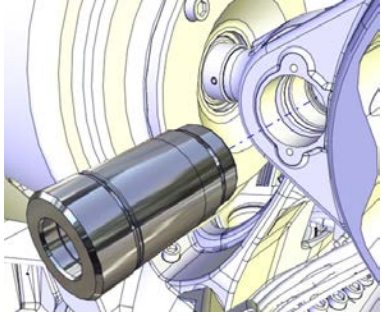
Continued

	Action	Note
7	<p>Align the balancing device link ear with the hole in the lower arm.</p> <p> Note</p> <p>Verify that the link ear is correctly turned.</p>	 <p>xx1300000784</p>
8	<p><i>Foundry Plus:</i></p> <p>Apply Mercasol on the surfaces on the shaft and front ear.</p>	 <p>xx1400000368</p> <p>A Front link ear B Shaft C Mercasol (red dotted lines)</p>
9	<p>Lubricate the shaft and place it to the front ear.</p> <p> Note</p> <p><i>Foundry Plus:</i></p> <p>Do not lubricate surfaces where Mercasol is applied.</p>	 <p>xx1200001280</p>

Continues on next page

4.8.4 Replacing the axis-2 gearbox (IRB 6700 - 300/2.70, IRB 6700 - 245/3.00)

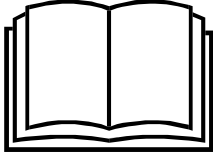
Continued

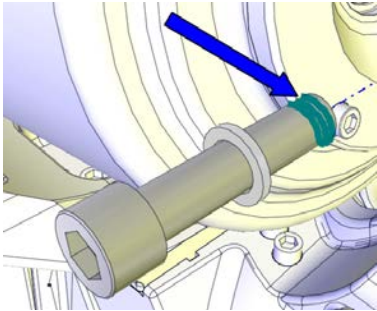
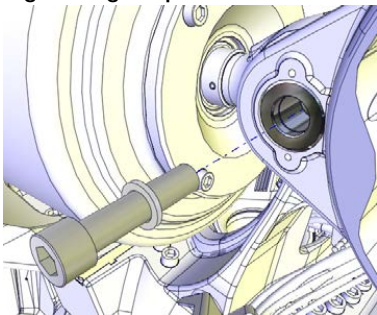
	Action	Note
10	<p>Press in the shaft using the dismantle and mounting tool, according to user instructions enclosed with the equipment.</p>  <p>xx0900000813</p> <p>Go to the user instructions enclosed with the press tool.</p> <p> DANGER</p> <p>Handling the tool incorrectly will cause serious injury.</p> <p>Read and follow enclosed user instructions for the tool.</p>	<p>Dismantle and mounting tool: 3HAC028920-001</p> <p>User instructions are enclosed with the tool.</p>
11	<p>Apply locking liquid (Loctite 2701) on the threads of the screw, first entering the threads in the frame.</p>	 <p>xx1300000782</p>
12	<p>Secure the shaft with screw and washer.</p>	<p>Tightening torque: 180 Nm</p>  <p>xx1200001279</p>

Continues on next page

4 Repair

4.8.4 Replacing the axis-2 gearbox (IRB 6700 - 300/2.70, IRB 6700 - 245/3.00)

Continued

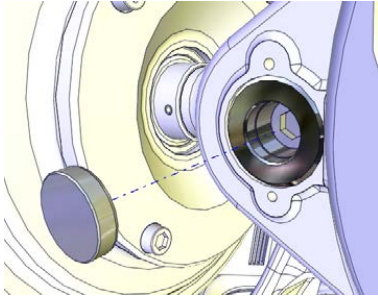
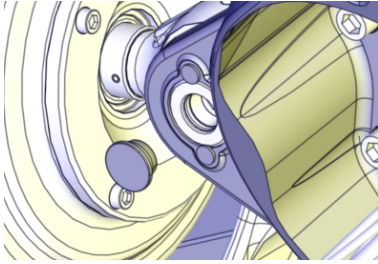
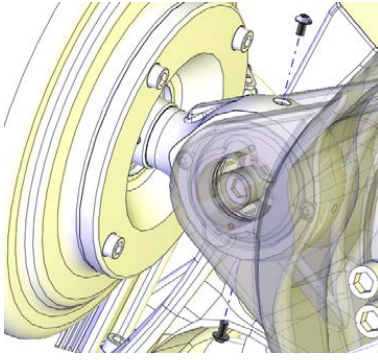
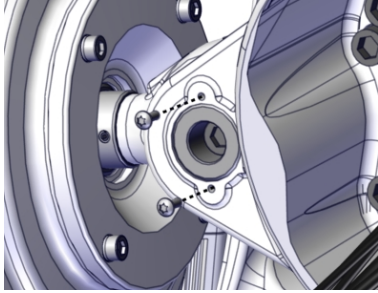
	Action	Note
13	Fit the protection plug or a new VK-cover (depends on shaft version).	 <p>xx1200001278</p>  <p>xx1900002311</p>
14	Unscrew both screws in link ear and fill the bearing with grease from the upper hole until the grease appears in the lower hole.	<p>Grease: 3HAA1001-294</p>  <p>xx1300000783</p>
15	Refit the two screws and wipe clean from residual grease.	<p>Tightening torque: 180 Nm</p>  <p>xx1900002146</p>



Concluded refitting of the front shaft

	Action	Note
1	Remove the lifting accessory from the balancing device.	

Continues on next page

4.8.4 Replacing the axis-2 gearbox (IRB 6700 - 300/2.70, IRB 6700 - 245/3.00)

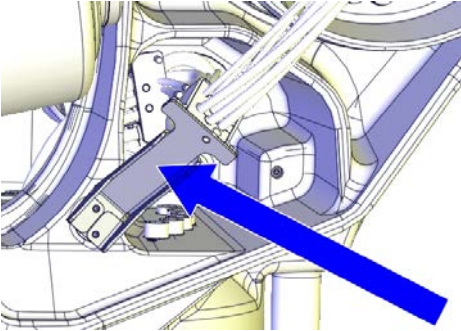
Continued

	Action	Note
2	Refit the cable bracket (if not already refitted).	 <p>xx1200001283</p>
3	<p> DANGER</p> <p>Do not use the Distance tool: 3HAC030662-001 to unload or restore the pressure of the balancing device spring unit! This tool is only used to lock the spring unit in a compressed position, after axis-2 has been jogged to -20° or $+20^\circ$. Fitting and removal of the tool shall only be done with axis-2 in this position!</p> <p>To unload or restore a new balancing device or if the spring unit of the balancing device cannot be compressed by jogging the robot, only use the hydraulic press tool Dismantle and mounting tool 3HAC028920-001.</p>	
4	<p>Jog axis-2 to:</p> <ul style="list-style-type: none"> • -30° or $+30^\circ$. 	This is done in order to compress the spring unit inside the balancing device before refitting or removal of the distance tool.
5	<p> DANGER</p> <p>Turn off all:</p> <ul style="list-style-type: none"> • electric power supply • hydraulic pressure supply • air pressure supply <p>to the robot, before entering the robot working area.</p>	

Continues on next page

4 Repair

4.8.4 Replacing the axis-2 gearbox (IRB 6700 - 300/2.70, IRB 6700 - 245/3.00)

Continued

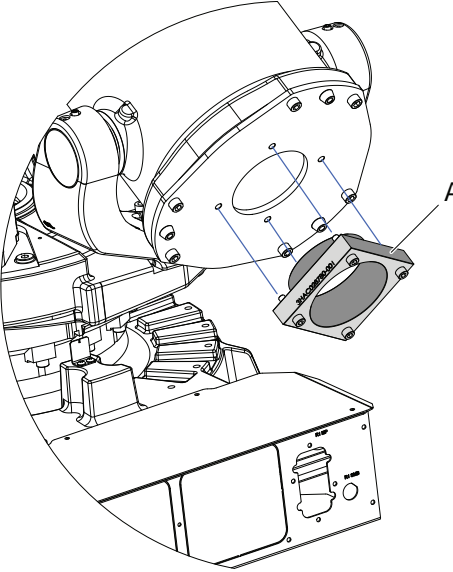
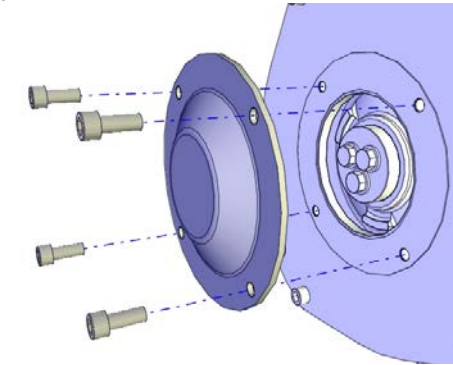
	Action	Note
6	Remove the distance tool.	 <p>xx0800000480</p> <p>A Distance tool: 3HAC030662-001</p>
7	Refit the cover plate.	<p>Attachment screws: M10 quality 12.9 (4 pcs)</p>  <p>xx1300000554</p>

Concluding procedure

	Action	Note
1	If the robot is equipped with DressPack, refit the brackets of the ball joint housings on the wrist.	
2	Refill oil to the axis-2 gearbox.	See Filling oil into the axis-2 gearbox on page 156 .
3	Re-calibrate the robot.	<p>Pendulum Calibration is described in Operating manual - Calibration Pendulum, enclosed with the calibration tools.</p> <p>Axis Calibration is described in Calibrating with Axis Calibration method on page 781.</p> <p>General calibration information is included in section Calibration on page 767.</p>

Continues on next page

4.8.4 Replacing the axis-2 gearbox (IRB 6700 - 300/2.70, IRB 6700 - 245/3.00)

Continued

	Action	Note
4	 DANGER Make sure all safety requirements are met when performing the first test run.	

4 Repair

4.8.5 Replacing the axis-3 gearbox

4.8.5 Replacing the axis-3 gearbox

Space required beside

This section describes how to replace the gearbox without needing to remove the cable harness and DressPack cable package (if installed) from the robot.

The described procedure requires free space on the floor, at the right-hand side of the balancing device (seen from behind). There should be enough space to place two pallets in a row.

If needed, run axis 1 into a position that gives the required space at the right-hand side of the balancing device.



DANGER

Do not unscrew the attachment screws that secure the robot to the foundation!
If unscrewed, the robot will be unstable.

Location of the axis-3 gearbox

The axis-3 gearbox is located as shown in the figure.

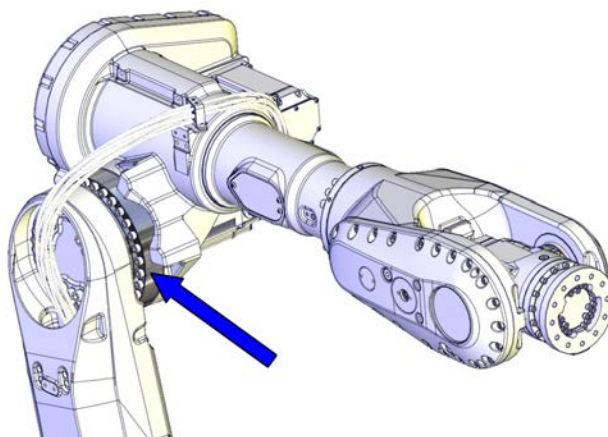

xx1300000515

Continues on next page

Summary of the replacement procedure

This list is a brief summary of the replacement procedure, containing the major actions to be performed.

- 1 Remove the upper arm from the robot and position it as shown in the figure, for easy removal of the axis-3 gearbox.

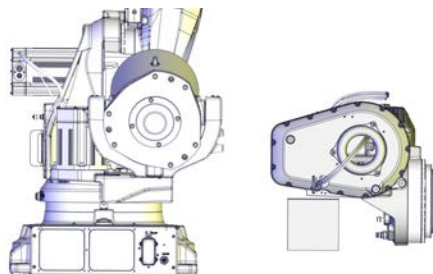

xx1300000553

When removing the upper arm, the cable harness can be kept fitted or partly fitted to the robot. Use caution not to cause any damage to the cable harness.

- 2 Replace the axis-3 gearbox.

Spare parts

Spare parts	Spare part number	Note
Axis-3 gearbox	See <i>Product manual, spare parts - IRB 6700/IRB 6700Inv.</i> <i>Product manual, spare parts - IRB 6790</i>	

Consumables

Equipment, etc	Article number	Note
Grease	3HAC042536-001	Shell Gadus S2 Used to lubricate o-rings.
Rust preventive	3HAC034903-001	Mercasol 3110 Waxcoat. Recommended drying time is 24h.
O-ring	3HAB3772-107	D=102x3 Used on motor flange.
O-ring ⁱ	3HAB3772-111 (circular profile) / 3HAC054692-002 (hexagon profile)	D=169.5x3 Used on motor cover.

Continues on next page

4 Repair

4.8.5 Replacing the axis-3 gearbox

Continued

Equipment, etc	Article number	Note
O-ring	3HAB3772-145 (D=266.3x3.5) (IRB 6700 - 235/2.65, IRB 6700 - 205/2.80, IRB 6700 - 175/3.05, IRB 6700 - 150/3.20) 3HAB3772-120 (D=264.3x5.7) (IRB 6700 - 200/2.60, IRB 6700 - 155/2.85)	Used on gearbox.

ⁱ The cross-section profile is either circular or hexagon. If only ordering the o-ring, order the same profile that is currently installed in the connection box.

Required tools and equipment

Equipment, etc.	Article number	Note
Oil collecting vessel	-	The capacity of the vessel must be sufficient to take the complete amount of oil.
Oil dispenser	-	One example of oil dispenser can be found in section Type of lubrication in gearboxes on page 145 .
Lifting eye	3HAC16131-1	M12
Lifting eye	3HAC14457-4	M16
Fender washer	-	Outer diameter: minimum 26 mm, maximum 30 mm, hole diameter: 13 mm, thickness: 3 mm.
Lifting accessory (chain)	3HAC15556-1	Lifting instruction 3HAC15880-2 enclosed.
Lifting accessory, gearbox	3HAC046128-001 ⁱ 3HACxx ⁱⁱ 3HAC046112-001 ⁱⁱⁱ	
Removal tool kit M12 and M14	3HAC057339-002	Used to push out the motor, if necessary. Always use removal tools in pairs. Size depending on motor type, see Type A vs type B motors on page 805 .
Screws M8x75, fully threaded	-	Used to push out the gearbox, if necessary.
Guide pin, M12x150	3HAC13056-2	Always use guide pins in pairs.
Guide pin, M16x200	3HAC13120-3	Always use guide pins in pairs.
Pinion	3HAC067546-001 ^{iv} 3HAC067547-001 ^v 3HAC067545-001 ^{vi}	Used for rotating the axis-3 gearbox when refitting upper arm.
24 VDC power supply	-	Used to release the motor brakes.
Leak-down tester	-	
Calibration Pendulum toolkit	3HAC15716-1	Required if Calibration Pendulum is the valid calibration method for the robot.
Calibration tool box, Axis Calibration	3HAC055412-001	Delivered as a set of calibration tools. Required if Axis Calibration is the valid calibration method for the robot.

Continues on next page

Equipment, etc.	Article number	Note
Standard toolkit	-	Content is defined in section Standard toolkit on page 814 .

- i IRB 6700 - 235/2.65, IRB 6700 - 205/2.80, IRB 6700 - 175/3.05, IRB 6700 - 150/3.20
- ii IRB 6700 - 200/2.60, IRB 6700 - 155/2.85
- iii IRB 6700 - 300/2.70, IRB 6700 - 245/3.00
- iv IRB 6700 - 235/2.65, IRB 6700 - 205/2.80, IRB 6700 - 175/3.05, IRB 6700 - 150/3.20
- v IRB 6700 - 200/2.60, IRB 6700 - 155/2.85
- vi IRB 6700 - 300/2.70, IRB 6700 - 245/3.00

Deciding calibration routine

Decide which calibration routine to be used, based on the information in the table. Depending on which routine is chosen, action might be required prior to beginning the repair work of the robot, see the table.

	Action	Note
1	Decide which calibration routine to use for calibrating the robot. <ul style="list-style-type: none"> • Reference calibration. External cable packages (DressPack) and tools can stay fitted on the robot. • Fine calibration. All external cable packages (DressPack) and tools must be removed from the robot. 	
	<p>If the robot is to be calibrated with reference calibration:</p> <p>Find previous reference values for the axis or create new reference values. These values are to be used after the repair procedure is completed, for calibration of the robot.</p> <p>If no previous reference values exist, and no new reference values can be created, then reference calibration is not possible.</p>	<p>Follow the instructions given in the reference calibration routine on the FlexPendant to create reference values.</p> <p>Creating new values requires possibility to move the robot.</p> <p>Read more about reference calibration for Axis Calibration in Reference calibration routine on page 782.</p> <p>Read more about reference calibration for Pendulum Calibration in <i>Operating manual - Calibration Pendulum</i>.</p>
	<p>If the robot is to be calibrated with fine calibration:</p> <p>Remove all external cable packages (DressPack) and tools from the robot.</p>	

Removing the axis-3 gearbox

Use these procedures to remove the axis-3 gearbox.

Follow the order of the separate procedure according to the order they are presented.

Preparations before removing the axis-3 gearbox



	Action	Note
1	Decide which calibration routine to use, and take actions accordingly prior to beginning the repair procedure.	

Continues on next page

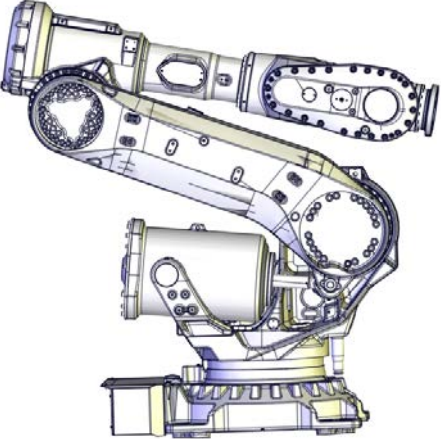

4 Repair

4.8.5 Replacing the axis-3 gearbox

Continued

	Action	Note
2	<p>Jog the robot to:</p> <ul style="list-style-type: none"> • Axis 1 = No significance (as long as the robot is secured to the foundation). • Axis 2 = -65° • Axis 3 = maximum + position, upper arm resting against the mechanical stop (approximately $+70^{\circ}$). • Axis 4 = 0° • Axis 5 = -90° • Axis 6 = 0° 	<p>If needed, run the axis-1 into a position that gives the required space (space to place two pallets in a row) at the right-hand side of the balancing device, as seen from behind.</p>  <p>xx180000029</p>
3	<p> DANGER</p> <p>When releasing the holding brakes of the motor, the upper arm will be movable and may fall down if not secured. Verify that the upper arm is secured as previously described, before continuing.</p>	
4	<p>Release the holding brakes for the axis-3 motor to make the upper arm rest tightly against the mechanical stop.</p>	
5	<p> DANGER</p> <p>Turn off all:</p> <ul style="list-style-type: none"> • electric power supply • hydraulic pressure supply • air pressure supply <p>to the robot, before entering the safeguarded space.</p>	
6	<p>Begin draining the gearbox.</p>	<p>See Draining the axis-3 gearbox on page 160.</p>

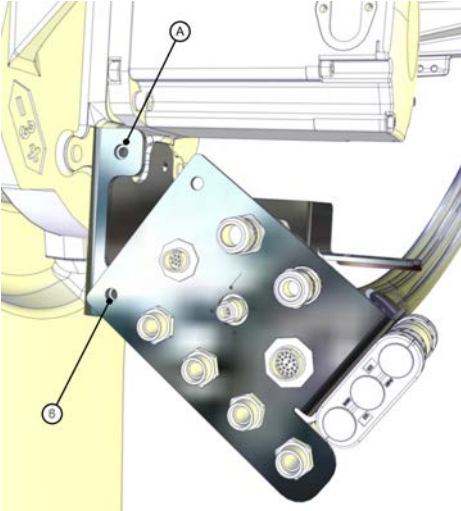
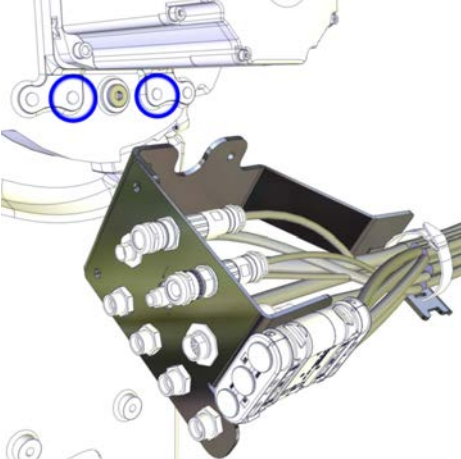
Continues on next page

	Action	Note
7	<p>Unscrew the uppermost attachment screw that holds the bracket of the DressPack cable package (if one is fitted), and let it "fall down" . See figure!</p> <p> Note</p> <p>It is not needed to disconnect the lower end connectors of the DressPack (as the figure shows). Connectors are only hidden to get a better view of which screw to be removed.</p>	 <p>xx1200001331</p> <p>A Attachment screw to be removed B Attachment screw not to be removed</p>
8	<p>Unscrew the two attachment screws that holds the bracket of the DressPack cable package (if one is fitted), and let it hang down together with the rest of the DressPack cable package.</p>	 <p>xx1200001332</p>
9	<p>Put two pallets on the floor, at the right-hand side of the robot.</p> <p> Note</p> <p>This position is only a recommendation. If it is not possible to put the upper arm close enough to the robot and keep the cable harness partly fitted, it may be necessary to remove the cable harness and DressPack in the upper arm and wrist first.</p>	

4 Repair

4.8.5 Replacing the axis-3 gearbox

Continued

Disconnecting the axis-3 and axis-4 motor cables

Use this procedure to disconnect the motor cables on the axis-3 and axis-4 motors.

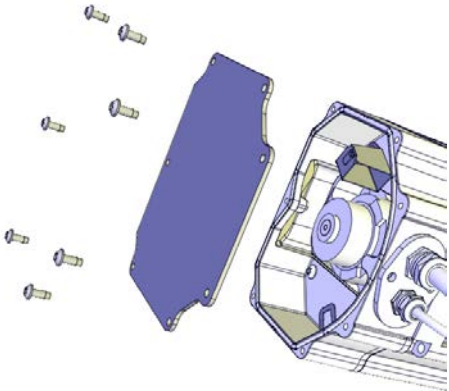
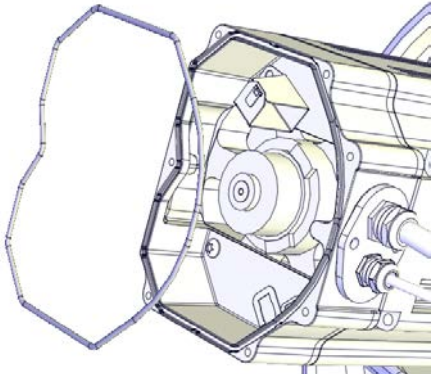
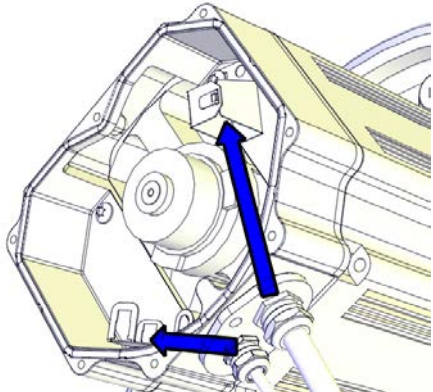
	Action	Note
1	 DANGER Make sure that all supplies for electrical power, hydraulic pressure, and air pressure are turned off.	
2	Unscrew the attachment screws and washers and remove the motor cover.	 xx1200001135
3	Make sure the o-ring is present.	 xx1200001070
4	Disconnect the motor cables.	 xx1200001066

Continues on next page

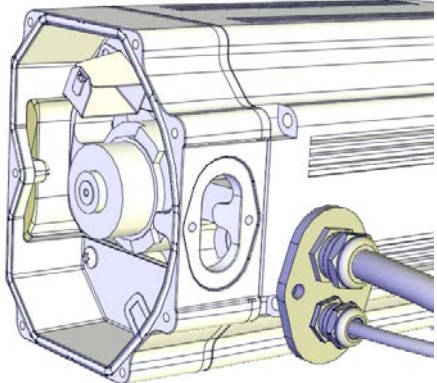
	Action	Note
5	<p>Remove the cable gland cover. Make sure the gasket is not damaged.</p> <p> Tip</p> <p>Make a note in which direction the cable gland hole is facing, if the motor will be removed too. The motor shall be refitted in the same position.</p>	 <p>xx1200001067</p>
6	Use caution and pull out the motor cables.	

Removing the axis-3 motor

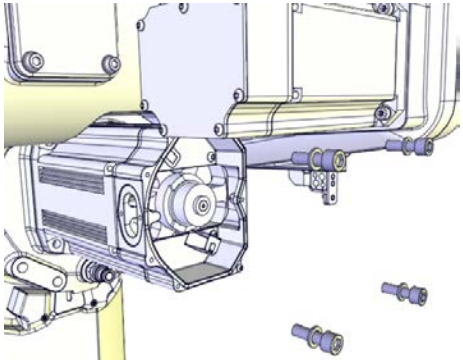



	Action	Note
1	Before removing the motor, make sure that the axis-3 gearbox is completely drained.	
2	<p> DANGER</p> <p>When releasing the holding brakes of the motor, the upper arm will be movable and may fall down if not secured. Verify that the upper arm is secured as previously described, before continuing.</p>	
3	<p>To release the brakes, connect the 24 VDC power supply.</p> <p>Connect to connector R2.MP3:</p> <ul style="list-style-type: none"> • + = pin 2 • - = pin 5 	
4	<p>Unscrew the attachment screws that hold the motor.</p> <p>Use a bits extender to reach the screws.</p>	<p>Bits extender: 3HAC12342-1</p>  <p>xx1200001126</p>

Continues on next page

4 Repair

4.8.5 Replacing the axis-3 gearbox

Continued

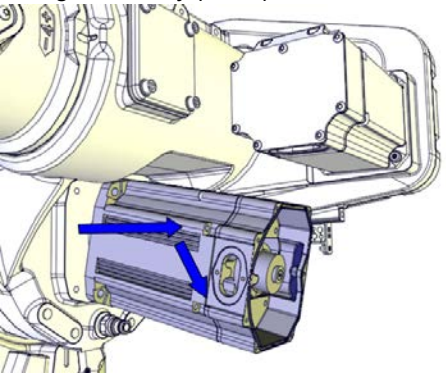
	Action	Note
5	Fit guide pins in opposite holes.  Tip Lubricate the guide pins with some grease to make the motor slide better.	Guide pin, M10x150: 3HAC15521-2 Always use guide pins in pairs.
6	 CAUTION Whenever parting/mating motor and gearbox, the gears may be damaged if excessive force is used.	
7	If required, press the motor out of position by using the removal tool in the remaining holes for the motor.	Removal tool kit M12 and M14: 3HAC057339-002 Removal tool kit M12 and M14: 3HAC057339-002 Depending on motor type A or B, see Identifying the motor by article number on page 805 Always use removal tools in pairs.
8	Use caution and lift the motor out on the guide pins, in order to get the pinion away from the gear, and let the motor rest on the guide pins.	
9	 CAUTION The motor weighs 26 kg. All lifting accessories used must be sized accordingly.	
10	Fasten the lifting accessory to the motor. Attach the lifting chain to the accessory and an overhead crane.	Lifting accessory, motor: 3HAC15534-1 Lifting accessory (chain): 3HAC15556-1
11	When the motor is hanging in the lifting accessory, and the pinion no longer is mated to the gear, let the outer end of the motor hang lower so that it will hang in an angle. This position makes it easier to remove the axis-3 motor with the axis-4 motor still fitted.  CAUTION The pinion must have been parted from the gear before the motor is angled. If not there is a risk of damaging the pinion and gear.	
12	Disconnect the 24 VDC power supply.	

Continues on next page

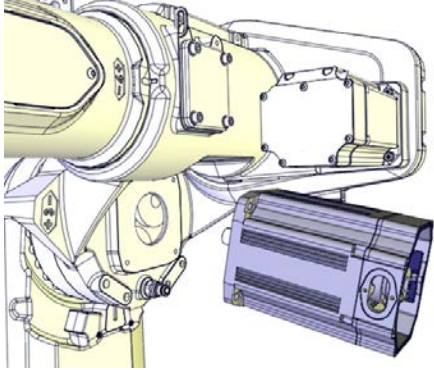
	Action	Note
13	Remove the motor by lifting it straight out.	<p>Make sure the pinion is not damaged.</p>  <p>xx1200001131</p>

Keeping cabling installed in upper arm - loosening the cable brackets

This procedure is valid if wanting to keep the cabling installed in the upper arm, when removing the upper arm from the robot. If this is not possible due to lack of space where to put the upper arm, the cable harness must be removed from the upper arm, see [Removing the cable harness - upper arm and wrist on page 221](#).

Use this procedure to loosen required cable brackets of the robot cable harness, in order to get the longest possible length of the cable harness between the lower and upper arm.

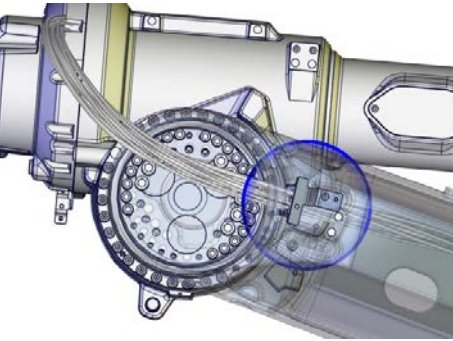

	Action	Note
1	<p>Unscrew the attachment screws that hold the axis-3 lower arm metal clamp (the one closest to the axis-3 gearbox) located on the inside of the lower arm.</p> <p> Note</p> <p>The screw is reached from the outside of the lower arm!</p>	 <p>xx1800000042</p>

Continues on next page

4 Repair

4.8.5 Replacing the axis-3 gearbox

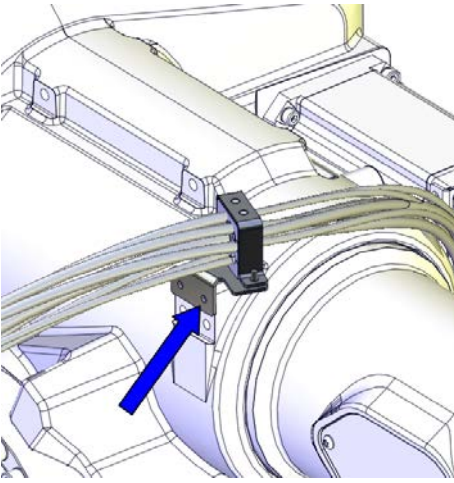
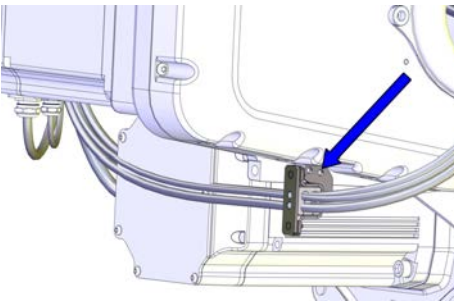
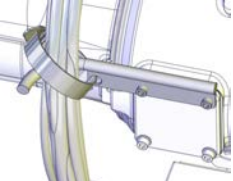
Continued

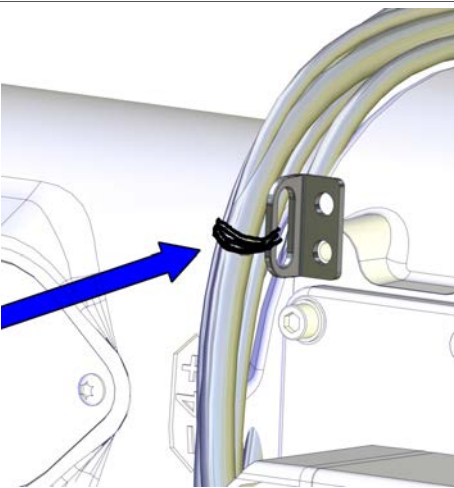
	Action	Note
2	Unscrew the attachment screws that hold the cable bracket on top of the arm house.	 xx130000541
3	Unscrew the attachment screws that hold the cable bracket under the arm house.	 xx130000543
4	Cut the cable tie at the cable fixing bracket.  xx1300001973	<p> Note If DressPack is fitted, the cable fixing bracket is replaced by the cable guide.</p>  xx130000544

Continues on next page

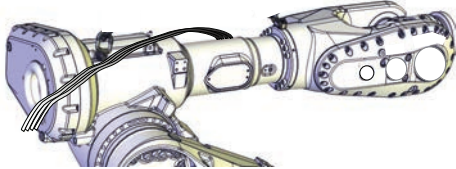
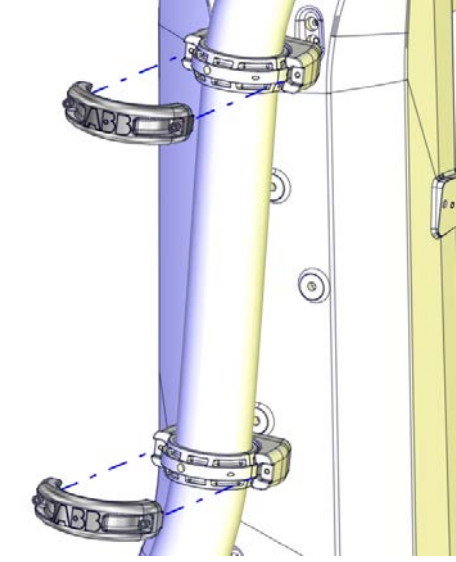
	Action	Note
5	<p>In order not to damage the cable harness later, it shall be moved over to the other side of the arm house and be placed on the right side (as seen from behind) of the back lifting eye. See figure!</p>	 <p>xx130000534</p>
6	<p>If the robot is equipped with DressPack:</p> <ul style="list-style-type: none"> • Open the two ball joint housings on the lower arm and lift away the cable harness from the ball joint housings. 	<p>How to remove the DressPack is described in more detail in the product manual "IRB 6700 DressPack". For article number see References on page 10.</p>  <p>xx140000195</p>
7	<p>If the robot is equipped with DressPack: Lift the DressPack cable package at the arm house up and put the cable bracket on the cable guide where the velcro strap normally is fitted. Secure the temporary position with a velcro strap or similar, to ensure it will not fall down or damage anything.</p>	



4 Repair

4.8.5 Replacing the axis-3 gearbox

Continued

Attaching the lifting accessories to the upper arm

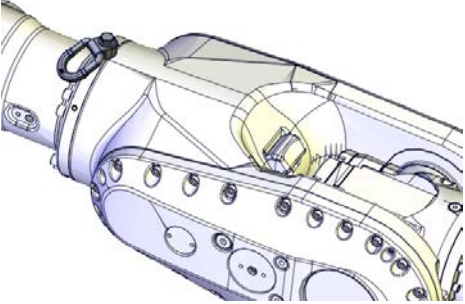

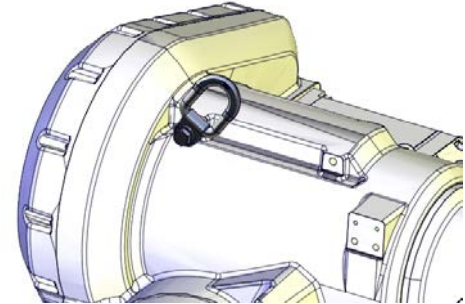
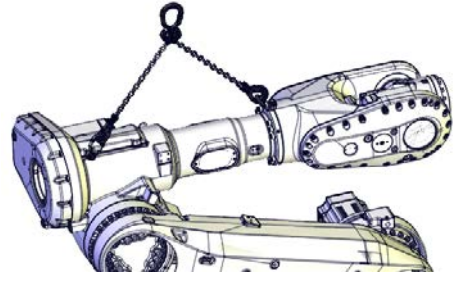
Use this procedure to attach the lifting accessories to the upper arm.

	Action	Note
1	<p> CAUTION</p> <p>The weight of the complete upper arm (including the wrist) is 360 kg (IRB 6700 -235/2.65, -205/2.80, -175/3.05, -150/3.20, -200/2.60, -155/2.85) 465 kg (IRB 6700 -300/2.70, -245/3.00) All lifting accessories used must be sized accordingly.</p>	
2	Fit a lifting eye to the wrist.	<p>Lifting eye: 3HAC16131-1</p>  <p>xx1200001133</p>
3	<p>Fit a lifting eye in the arm house, with a fender washer underneath.</p>  <p>xx1400002196</p>	<p>Lifting eye: 3HAC16131-1 Fender washer: Outer diameter: minimum 26 mm, maximum 30 mm, hole diameter: 13 mm, thickness: 3 mm.</p>  <p>xx1200001134</p>
4	Attach the upper arm lifting accessory (chain) to an overhead crane (or similar) and then to the lifting eye in the arm house and in the wrist.	<p>Lifting accessory (chain): 3HAC15556-1</p>  <p>xx1200001308</p>

Continues on next page

	Action	Note
5	Raise the lifting accessories to take the weight of the upper arm.	
6	In case of necessary adjustments, use the shortening loops on the lifting accessory (chain) to find the level position.	 <p data-bbox="970 730 1078 748">xx1400002197</p>

Preparations before removing the upper arm - IRB 6700 - 235/2.65, IRB 6700 - 205/2.80, IRB 6700 - 175/3.05, IRB 6700 - 150/3.20

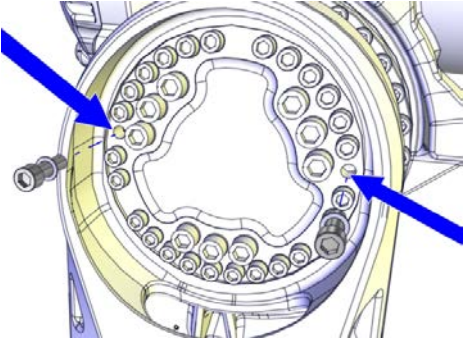
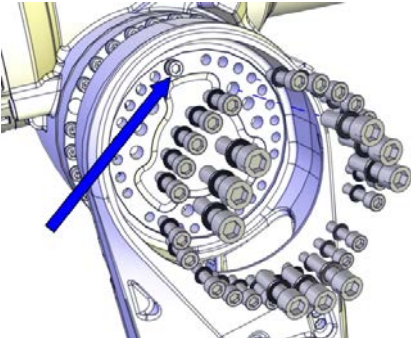
	Action	Note
1	<p data-bbox="497 936 960 1016">Remove two attachment screws (M12) in opposite holes and replace them with guide pins.</p> <p data-bbox="497 1034 644 1093">  Note Make sure that it is the screws that hold the lower arm to the axis-3 gearbox that are removed! </p> <p data-bbox="497 1205 628 1263">  Tip Lubricate the guide pins with some grease to make the upper arm slide better. </p>	<p data-bbox="973 936 1362 1034"> Guide pin, M12x150: 3HAC13056-2 Guide pin, M12x200: 3HAC13056-3 Always use guide pins in pairs. </p>  <p data-bbox="973 1379 1078 1397">xx130000659</p>
2	<p data-bbox="497 1435 935 1494">Leave one of the remaining attachment screws fitted, remove the other screws.</p>	 <p data-bbox="973 1774 1078 1792">xx130000747</p>



Continues on next page

4 Repair



4.8.5 Replacing the axis-3 gearbox

Continued

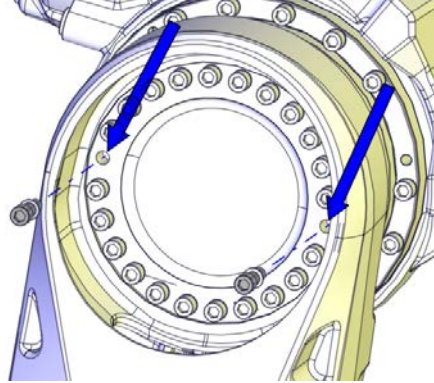
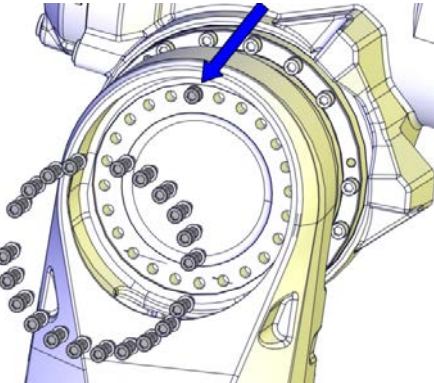
Preparations before removing the upper arm - IRB 6700 - 200/2.60, IRB 6700 - 155/2.85

	Action	Note
1	<p>Remove two attachment screws in opposite holes and replace them with guide pins.</p> <p> Note</p> <p>Make sure that it is the screws that hold the lower arm to the axis-3 gearbox that are removed!</p> <p> Tip</p> <p>Lubricate the guide pins with some grease to make the upper arm slide better.</p>	<p>Guide pin, M12x150: 3HAC13056-2 Guide pin, M12x200: 3HAC13056-3 Always use guide pins in pairs.</p>  <p>xx1300002245</p>
2	<p>Leave one of the remaining attachment screws fitted, remove the other screws.</p>	 <p>xx1300002246</p>

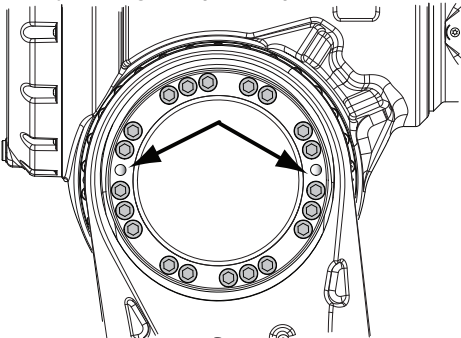

Preparations before removing the upper arm - IRB 6700 - 300/2.70, IRB 6700 - 245/3.00

	Action	Note
1	<p>Remove two attachment screws in opposite holes and replace them with guide pins.</p> <p> Note</p> <p>Make sure that it is the screws that hold the lower arm to the axis-3 gearbox that are removed!</p> <p> Tip</p> <p>Lubricate the guide pins with some grease to make the upper arm slide better.</p>	<p>Guide pin, M16x150: 3HAC13120-2 Guide pin, M16x200: 3HAC13120-3 Always use guide pins in pairs.</p>  <p>xx1400002563</p>

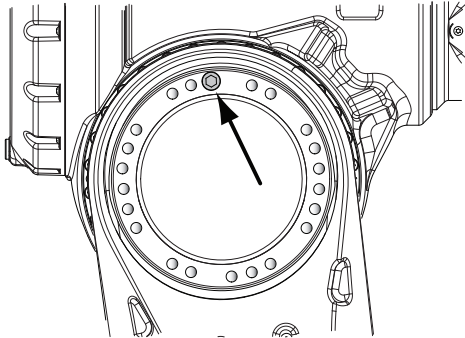
Continues on next page

	Action	Note
2	<p>Leave one of the remaining attachment screws fitted, remove the other screws.</p>	 <p>xx1400002564</p>

Removing the upper arm



	Action	Note
1	<p> Note</p> <p>Make sure the lift is done completely leveled! In case of necessary adjustments, use the shortening loops on the lifting accessory (chain), and make sure to place the chain the right way through the loops.</p>	 <p>xx1400002197</p>

Continues on next page

4 Repair

4.8.5 Replacing the axis-3 gearbox

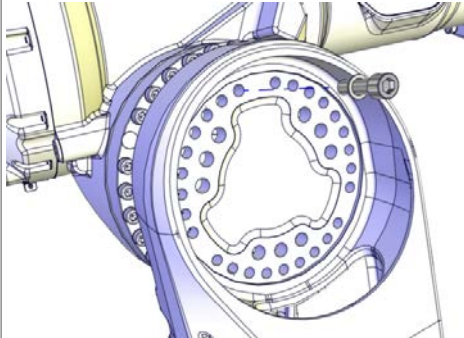
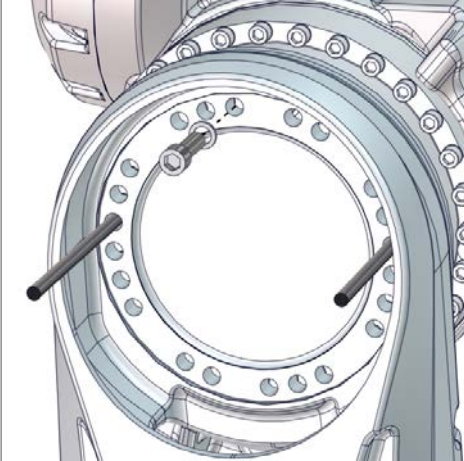
Continued

	Action	Note
2	<p>Remove the remaining attachment screw and let the upper arm slide out from the lower arm with support from the guide pins.</p>	<p>IRB 6700 - 235/2.65, IRB 6700 - 205/2.80, IRB 6700 - 175/3.05, IRB 6700 - 150/3.20</p>  <p>xx1300001610</p> <p>IRB 6700 - 200/2.60, IRB 6700 - 155/2.85 TBD IRB 6700 - 300/2.70, IRB 6700 - 245/3.00</p>  <p>xx170000059</p>
3	<p>Lift the upper arm and place it on the prepared area.</p> <p> CAUTION</p> <p><i>Only valid when the upper arm is removed due to replacement of the axis-3 gearbox:</i> If the cable harness is still fitted or partly fitted, use caution when lifting the upper arm over to the other side of the robot, in order not to cause any damage to the cable harness.</p>	

Continues on next page

4.8.5 Replacing the axis-3 gearbox
Continued

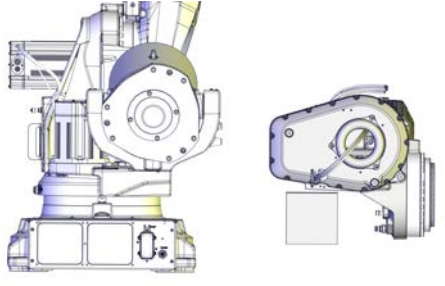
	Action	Note
4	<p><i>This step is only valid when the upper arm is removed due to replacement of the axis-3 gearbox:</i></p> <p>Place pieces of wood (or similar) under arm house and wrist. Lower the upper arm, and let the upper arm rest as shown in the figure.</p> <p>This is done in order to keep the axis-3 gearbox in a vertical position and to get the best position to replace the axis-3 gearbox, if applicable.</p>	 <p>xx1300000553</p>

Removing the axis-3 gearbox

Use this procedure to remove the gearbox.

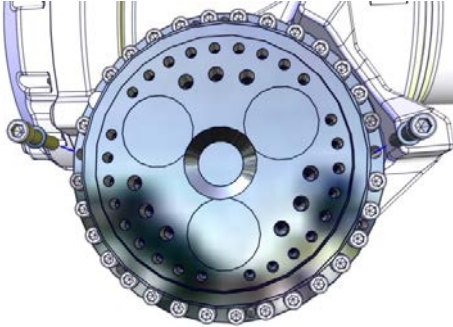
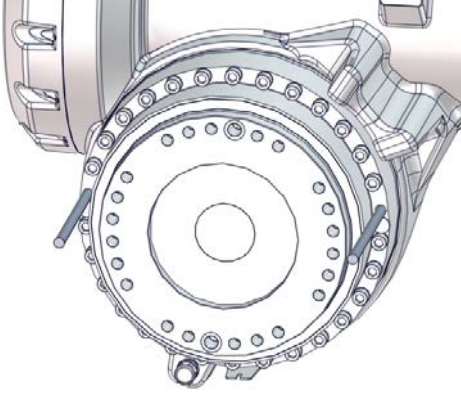

	Action	Note
1	<p>Remove two attachment screws in opposite holes and replace them with guide pins.</p> <p> Tip</p> <p>Lubricate the guide pins with some grease to make the gearbox slide better.</p>	<p>Guide pin, M12x150: 3HAC13056-2 Always use guide pins in pairs. IRB 6700 - 235/2.65, IRB 6700 - 205/2.80, IRB 6700 - 175/3.05, IRB 6700 - 150/3.20</p>  <p>xx1300001969</p> <p>IRB 6700 - 200/2.60, IRB 6700 - 155/2.85 TBD IRB 6700 - 300/2.70, IRB 6700 - 245/3.00</p>  <p>xx1700000370</p>

Continues on next page

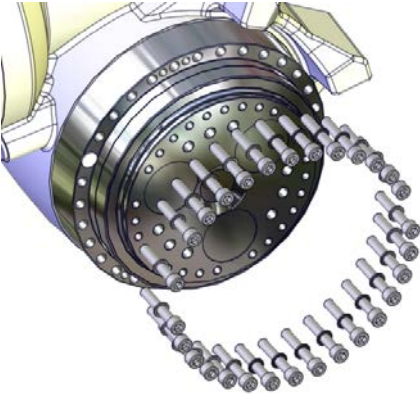
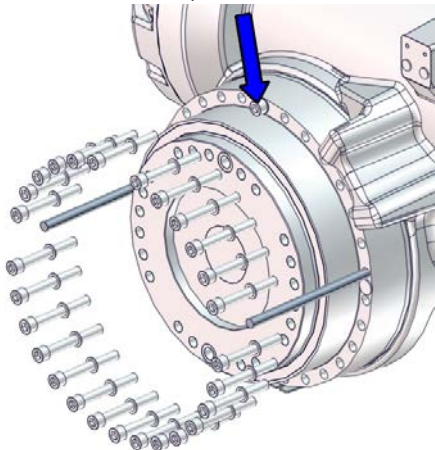

4 Repair

4.8.5 Replacing the axis-3 gearbox

Continued

	Action	Note
2	Remove all but one of the remaining attachment screws.	<p>IRB 6700 - 235/2.65, IRB 6700 - 205/2.80, IRB 6700 - 175/3.05, IRB 6700 - 150/3.20</p>  <p>xx1300001970</p> <p>IRB 6700 - 200/2.60, IRB 6700 - 155/2.85 TBD IRB 6700 - 300/2.70, IRB 6700 - 245/3.00</p>  <p>xx1700000371</p>
3	Fit two fully threaded screws and use them as removal tools.	Removal tool motor M10: Used to push out the motor, if necessary.
4	Remove the remaining attachment screw.	
5	<p>Loosen the gearbox from its fitting position with the help of the removal tools, but only pull it out on the guide pins a little.</p> <p> DANGER</p> <p>There is a risk that the gearbox may glide out and fall down before the lifting accessory is applied, if pulled out too far.</p>	

Continues on next page

	Action	Note
6	 CAUTION The axis-3 gearbox weighs . <ul style="list-style-type: none"> • 56 kg (IRB 6700 - 235/2.65, - 205/2.80, - 175/3.05, - 150/3.20, - 200/2.60, - 155/2.85) • 85 kg (IRB 6700 - 300/2.70, - 245/3.00) All lifting accessories used must be sized accordingly.	
7	Apply the lifting accessory to the gearbox.	Lifting accessory, gearbox: 3HAC046128-001 ⁱ 3HACxx ⁱⁱ 3HAC046112-001 ⁱⁱⁱ
8	 Note There will be some oil spill when the gearbox is removed. Put some oil absorbent cloth or paper below the gearbox.	
9	With the gearbox attached to the lifting accessory, remove the gearbox by letting it slide out on the guide pins.	
10	Remove the gearbox.	

ⁱ IRB 6700 - 235/2.65, IRB 6700 - 205/2.80, IRB 6700 - 175/3.05, IRB 6700 - 150/3.20

ⁱⁱ IRB 6700 - 200/2.60, IRB 6700 - 155/2.85

ⁱⁱⁱ IRB 6700 - 300/2.70, IRB 6700 - 245/3.00

Refitting the axis-3 gearbox

Use these procedures to refit the axis-3 gearbox.

Follow the order of the separate procedures according to the order they are presented.

Preparations before refitting the axis-3 gearbox



	Action	Note
1	 DANGER Make sure that all supplies for electrical power, hydraulic pressure, and air pressure are turned off.	

Continues on next page

4 Repair

4.8.5 Replacing the axis-3 gearbox

Continued

	Action	Note
2	 CAUTION The axis-3 gearbox weighs . <ul style="list-style-type: none"> • 56 kg (IRB 6700 - 235/2.65, - 205/2.80, - 175/3.05, - 150/3.20, - 200/2.60, - 155/2.85) • 85 kg (IRB 6700 - 300/2.70, - 245/3.00) All lifting accessories used must be sized accordingly.	
3	Apply the lifting accessory to the gearbox.	Lifting accessory, gearbox: 3HAC046128-001 ⁱ 3HACxx ⁱⁱ 3HAC046112-001 ⁱⁱⁱ
4	Lift the gearbox so that it rests on the side.	
5	Remove the o-ring and wipe it clean.  Note This shall also be done on a new spare part.	
6	Check the condition of the o-ring. Replace if damaged.	O-ring: . 3HAB3772-145 (D=266.3x3.5) (IRB 6700 - 235/2.65, IRB 6700 - 205/2.80, IRB 6700 - 175/3.05, IRB 6700 - 150/3.20) 3HAB3772-120 (D=264.3x5.7) (IRB 6700 - 200/2.60, IRB 6700 - 155/2.85)
7	Wipe clean the contact surfaces, both on the gearbox and in the upper arm. Also wipe clean the o-ring groove.	
8	Lubricate the o-ring with some grease.	
9	Fit the o-ring in the groove.	
10	Fit two guide pins in opposite holes.  Tip Lubricate the guide pins with some grease to make the gearbox slide better.	Guide pin, M12x150: 3HAC13056-2 Always use guide pins in pairs.
11	Lift the gearbox to the upper arm and let it rest on the guide pins.	

ⁱ IRB 6700 - 235/2.65, IRB 6700 - 205/2.80, IRB 6700 - 175/3.05, IRB 6700 - 150/3.20

ⁱⁱ IRB 6700 - 200/2.60, IRB 6700 - 155/2.85

ⁱⁱⁱ IRB 6700 - 300/2.70, IRB 6700 - 245/3.00

Continues on next page

Securing the axis-3 gearbox - IRB 6700 - 235/2.65, IRB 6700 - 205/2.80, IRB 6700 - 175/3.05, IRB 6700 - 150/3.20

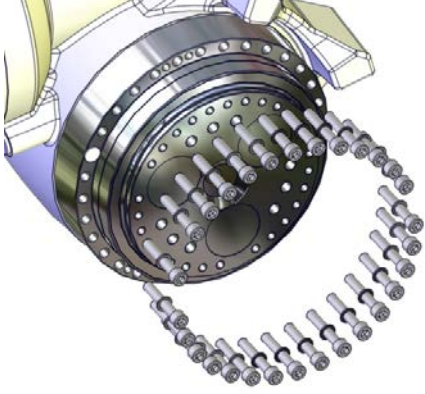
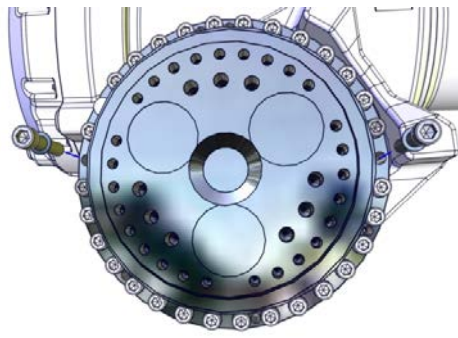
	Action	Note
1	Secure the gearbox with 29 of the 31 attachment screws and washers.	<p>Screws: M12x70 Tightening torque: 120 Nm</p>  <p>xx1300001970</p>
2	Remove the guide pins and replace with the remaining attachment screws and washers.	<p>Screws: M12x70.</p>  <p>xx1300001969</p>
3	Secure the remaining attachment screws.	Tightening torque: 120 Nm.
4	Remove the lifting accessory.	

Continues on next page

4 Repair

4.8.5 Replacing the axis-3 gearbox

Continued

Securing the axis-3 gearbox - IRB 6700 - 200/2.60, IRB 6700 - 155/2.85

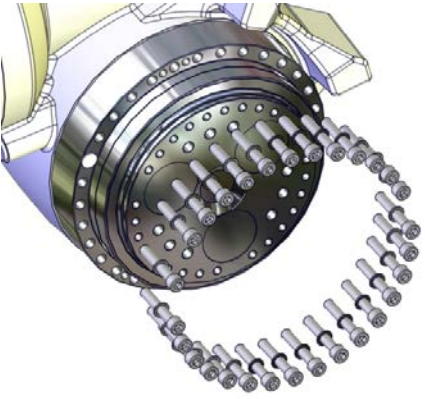
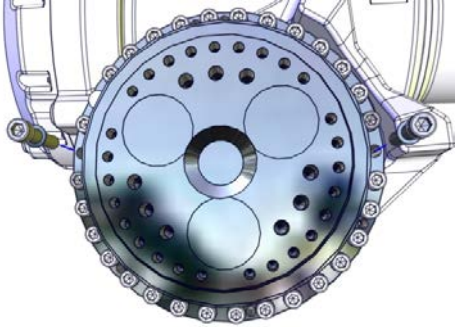
	Action	Note
1	Secure the gearbox with 13 of the 15 attachment screws.	Tightening torque: 120 Nm M12x70.  xx1300001970
2	Remove the guide pins and replace with the remaining attachment screws.	 xx1300001969
3	Secure the remaining attachment screws.	Tightening torque: 120 Nm. M12x70.
4	Remove the lifting accessory.	

Securing the axis-3 gearbox - IRB 6700 - 300/2.70, IRB 6700 - 245/3.00

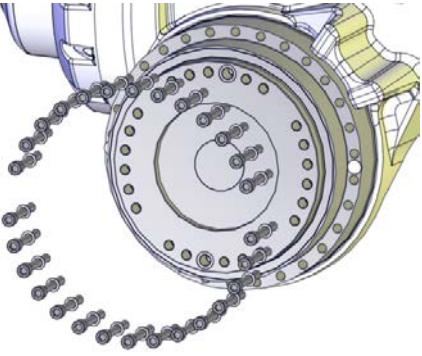
	Action	Note
1	Secure the gearbox with 28 of the 30 attachment screws.	Tightening torque: 120 Nm M12x70.  xx1400002193

Continues on next page

4.8.5 Replacing the axis-3 gearbox
Continued

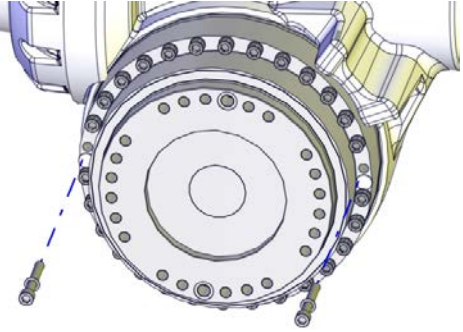
	Action	Note
2	Remove the guide pins and replace with the remaining attachment screws.	 <p>xx1400002194</p>
3	Secure the remaining attachment screws.	Tightening torque: 120 Nm. M12x70.
4	Remove the lifting accessory.	

Preparations before refitting the upper arm

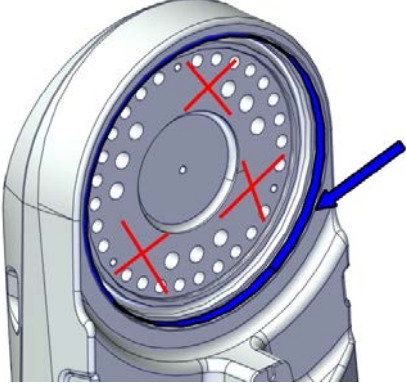



	Action	Note
1	Wipe clean all contact surfaces.	
2	<p><i>Foundry Plus:</i> Apply Mercasol on the surface on the lower arm as shown in the figure.</p> <p> CAUTION</p> <p>Keep the sealing surfaces clean from Mercasol.</p>	<p>Rust preventive: 3HAC034903-001 (Mercasol 3110 Waxcoat. Recommended drying time is 24h.)</p>  <p>xx1700001880</p>

Continues on next page

4 Repair

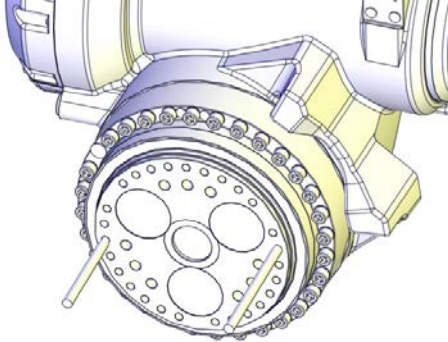
4.8.5 Replacing the axis-3 gearbox

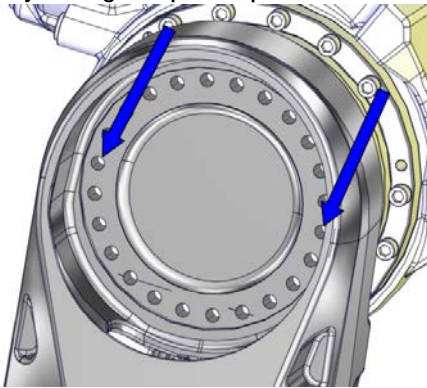
Continued

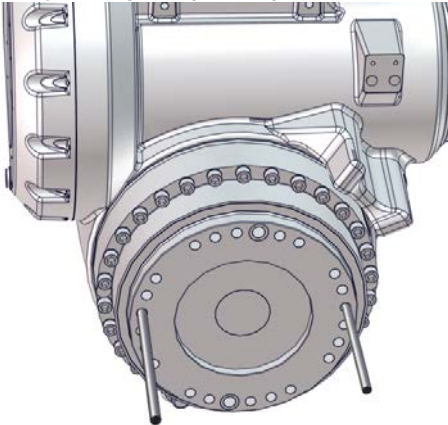
	Action	Note
3	<p>IRB 6700 - 235/2.65, IRB 6700 - 205/2.80, IRB 6700 - 175/3.05, IRB 6700 - 150/3.20</p> <p>Fit two guide pins in opposite M12 holes in the axis-3 gearbox.</p> <p> Tip</p> <p>Lubricate the guide pins with some grease to make the upper arm slide better.</p>	<p>Guide pin, M12x150: 3HAC13056-2 Guide pin, M12x200: 3HAC13056-3 Always use guide pins in pairs.</p>  <p>xx170000058</p>
4	<p>IRB 6700 - 200/2.60, IRB 6700 - 155/2.85</p> <p>Fit two guide pins in opposite M12 holes in the axis-3 gearbox.</p> <p> Tip</p> <p>Lubricate the guide pins with some grease to make the upper arm slide better.</p>	<p>Guide pin, M12x150: 3HAC13056-2 Guide pin, M12x200: 3HAC13056-3 Always use guide pins in pairs.</p>  <p>xx1400000361</p>
5	<p>IRB 6700 - 300/2.70, IRB 6700 - 245/3.00</p> <p>Fit two guide pins in opposite M16 holes in the axis-3 gearbox.</p> <p> Tip</p> <p>Lubricate the guide pins with some grease to make the upper arm slide better.</p>	<p>Guide pin, M16x150: 3HAC13120-2 Guide pin, M16x200: 3HAC13120-3 Always use guide pins in pairs.</p>  <p>xx170000056</p>

Continues on next page

Securing the upper arm - IRB 6700 - 235/2.65, IRB 6700 - 205/2.80, IRB 6700 - 175/3.05, IRB 6700 - 150/3.20

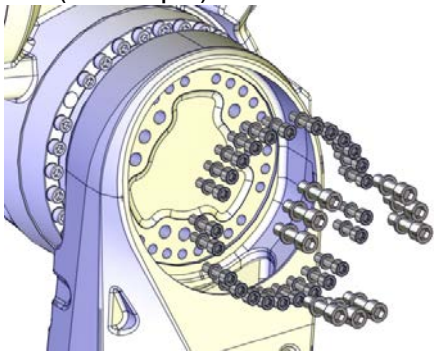
	Action	Note
1	<p> CAUTION</p> <p>The weight of the complete upper arm (including the wrist) is 360 kg (IRB 6700 -235/2.65, -205/2.80, -175/3.05, -150/3.20, -200/2.60, -155/2.85) 465 kg (IRB 6700 -300/2.70, -245/3.00) All lifting accessories used must be sized accordingly.</p>	
2	Attach the lifting accessories, if not already fitted.	See Attaching lifting accessories to the upper arm on page 216 .
3	Lift the upper arm and put it on the guide pins.	
4	<p>If the axis-3 motor is installed to the upper arm: In order to release the brakes, connect the 24 VDC power supply. Connect to R2.MP3-connector:</p> <ul style="list-style-type: none"> • + = pin 2 • - = pin 5 <p>Use the rotation tool and rotate the axis-3 motor to find the correct position for the guide pins in the lower arm.</p>	24 VDC power supply Rotation tool
5	<p>If the axis-3 motor is not installed to the upper arm: Use the pinion to rotate the axis-3 gearbox to find the correct position for the guide pins in the lower arm.</p>	Pinion: 3HAC067546-001 ⁱ 3HAC067547-001 ⁱⁱ 3HAC067545-001 ⁱⁱⁱ
6	Insert all nine M16 screws and 25 of the 27 M12 screws.	Screws: M16 (9 pcs) M12 (25 of 27 pcs)  xx1400000359

Continues on next page

4 Repair

4.8.5 Replacing the axis-3 gearbox

Continued

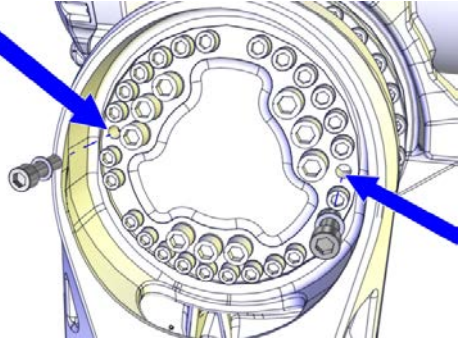
	Action	Note
7	Remove the guide pins and fit the two remaining M12 screws.	 <p data-bbox="948 658 1050 674">xx130000659</p>
8	Secure the upper arm by tightening the attachment screws.	<p data-bbox="948 712 1399 763">Tightening torque depends on screw dimension.</p> <p data-bbox="948 770 1299 799">Tightening torque, M16: 300 Nm</p> <p data-bbox="948 806 1299 835">Tightening torque, M12: 120 Nm</p>

i IRB 6700 - 235/2.65, IRB 6700 - 205/2.80, IRB 6700 - 175/3.05, IRB 6700 - 150/3.20

ii IRB 6700 - 200/2.60, IRB 6700 - 155/2.85

iii IRB 6700 - 300/2.70, IRB 6700 - 245/3.00

Securing the upper arm - IRB 6700 - 200/2.60, IRB 6700 - 155/2.85

	Action	Note
1	<p data-bbox="475 1070 671 1122"> CAUTION</p> <p data-bbox="464 1137 932 1352">The weight of the complete upper arm (including the wrist) is 360 kg (IRB 6700 -235/2.65, -205/2.80, -175/3.05, -150/3.20, -200/2.60, -155/2.85) 465 kg (IRB 6700 -300/2.70, -245/3.00) All lifting accessories used must be sized accordingly.</p>	
2	Attach the lifting accessories, if not already fitted.	See Attaching lifting accessories to the upper arm on page 216 .
3	Lift the upper arm and put it on the guide pins.	
4	<p data-bbox="464 1532 932 1583">If the axis-3 motor is installed to the upper arm:</p> <p data-bbox="464 1590 932 1641">In order to release the brakes, connect the 24 VDC power supply.</p> <p data-bbox="464 1648 932 1700">Connect to R2.MP3-connector:</p> <ul data-bbox="501 1706 639 1736" style="list-style-type: none"> • + = pin 2 • - = pin 5 <p data-bbox="464 1742 932 1823">Use the rotation tool and rotate the axis-3 motor to find the correct position for the guide pins in the lower arm.</p>	<p data-bbox="948 1532 1182 1561">24 VDC power supply</p> <p data-bbox="948 1568 1086 1597">Rotation tool</p>
5	<p data-bbox="464 1843 932 1895">If the axis-3 motor is not installed to the upper arm:</p> <p data-bbox="464 1901 932 1982">Use the pinion to rotate the axis-3 gearbox to find the correct position for the guide pins in the lower arm.</p>	<p data-bbox="948 1843 1023 1872">Pinion:</p> <p data-bbox="948 1879 1150 1908">3HAC067546-001 ⁱ</p> <p data-bbox="948 1915 1150 1944">3HAC067547-001 ⁱⁱ</p> <p data-bbox="948 1951 1150 1980">3HAC067545-001 ⁱⁱⁱ</p>

Continues on next page

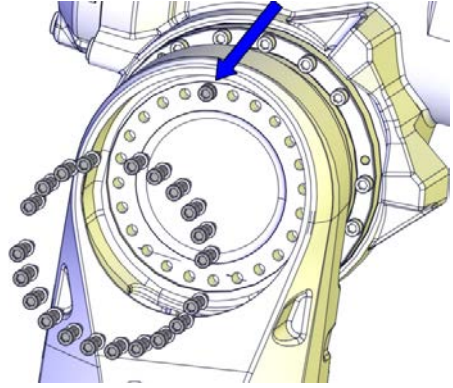
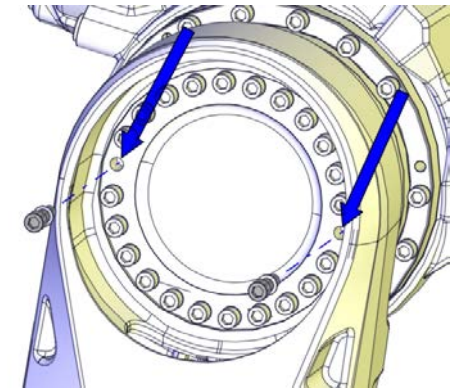
Action	Note
6 Insert 22 of the 24 M12 screws and washers.	 xx1300002246
7 Remove the guide pins and fit the two remaining screws and washers.	 xx1300002245
8 Secure the upper arm by tightening the attachment screws.	M12, tightening torque: 120 Nm

- i IRB 6700 - 235/2.65, IRB 6700 - 205/2.80, IRB 6700 - 175/3.05, IRB 6700 - 150/3.20
- ii IRB 6700 - 200/2.60, IRB 6700 - 155/2.85
- iii IRB 6700 - 300/2.70, IRB 6700 - 245/3.00

Securing the upper arm - IRB 6700 - 300/2.70, IRB 6700 - 245/3.00

Action	Note
<p>1  CAUTION</p> <p>The weight of the complete upper arm (including the wrist) is 360 kg (IRB 6700 -235/2.65, -205/2.80, -175/3.05, -150/3.20, -200/2.60, -155/2.85) 465 kg (IRB 6700 -300/2.70, -245/3.00) All lifting accessories used must be sized accordingly.</p>	
2 Attach the lifting accessories, if not already fitted.	See Attaching lifting accessories to the upper arm on page 216 .
3 Lift the upper arm and bring it towards the lower arm.	

Continues on next page

4 Repair

4.8.5 Replacing the axis-3 gearbox

Continued

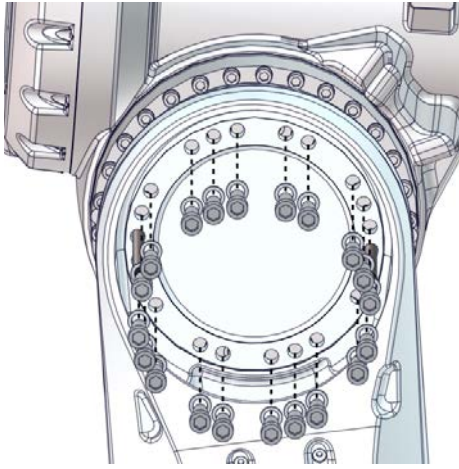
	Action	Note
4	<p>If the axis-3 motor is installed to the upper arm: Connect the 24 VDC power supply, to release the brakes. Connect to R2.MP3-connector:</p> <ul style="list-style-type: none"> • + = pin 2 • - = pin 5 <p>Use the rotation tool and rotate the axis-3 motor to find the correct position for the guide pins in the lower arm. Disconnect and remove the 24 VDC power supply after finding the position.</p>	<p>24 VDC power supply Rotation tool</p>
5	<p>If the axis-3 motor is not installed to the upper arm: Use the pinion to rotate the axis-3 gearbox to find the correct position for the guide pins in the lower arm.</p>	<p>Pinion: 3HAC067546-001 ⁱ 3HAC067547-001 ⁱⁱ 3HAC067545-001 ⁱⁱⁱ</p>
6	<p>Insert and tighten 20 of the 22 M16 screws.</p>	 <p>xx1700000057</p>
7	<p>Remove the guide pins and fit the two remaining screws.</p>	
8	<p>Secure the upper arm by tightening the attachment screws.</p>	<p>M16, tightening torque: 300 Nm</p>

ⁱ IRB 6700 - 235/2.65, IRB 6700 - 205/2.80, IRB 6700 - 175/3.05, IRB 6700 - 150/3.20



ⁱⁱ IRB 6700 - 200/2.60, IRB 6700 - 155/2.85

ⁱⁱⁱ IRB 6700 - 300/2.70, IRB 6700 - 245/3.00

Preparations prior to refitting motor

	Action	Note
1	 <p>DANGER</p> <p>Make sure that all supplies for electrical power, hydraulic pressure, and air pressure are turned off.</p>	

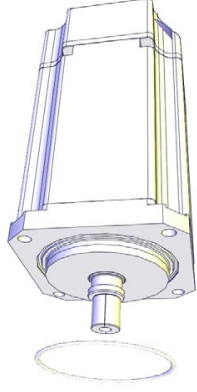
Continues on next page

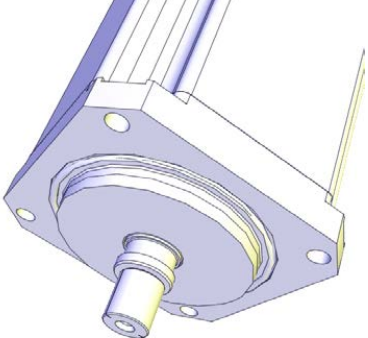
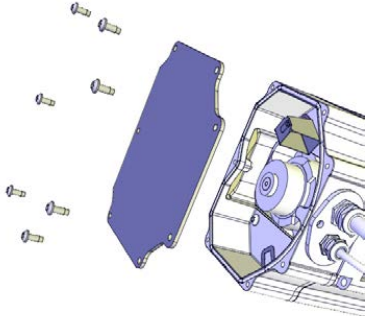
	Action	Note
2	Remove any old paint residues or other contamination from the contact surfaces on both the motor and the mating parts. Wipe clean the contact surfaces and the o-ring groove.	
3	Fit a new o-ring.	 <p>xx1200001019</p>
4	Make sure the o-ring is seated in the groove.  Tip Lubricate the o-ring with some grease for a better fitting in the groove.	 <p>xx1200001020</p>
5	If the motor is a new spare part, remove the cover.	 <p>xx1200001135</p>

Securing the axis-3 motor

Use this procedure to secure the motor.



	Action	Note
1	Fit guide pins in opposite holes.	Guide pin, M10x150: 3HAC15521-2 Always use guide pins in pairs.

Continues on next page

4 Repair

4.8.5 Replacing the axis-3 gearbox

Continued

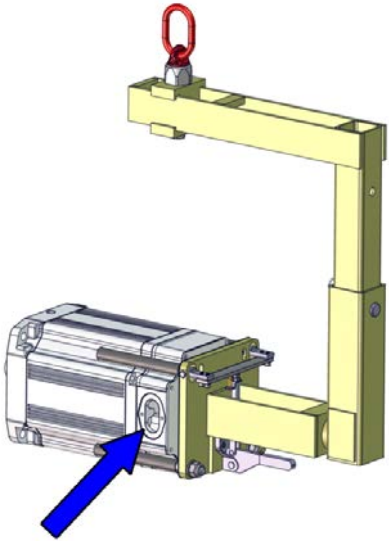
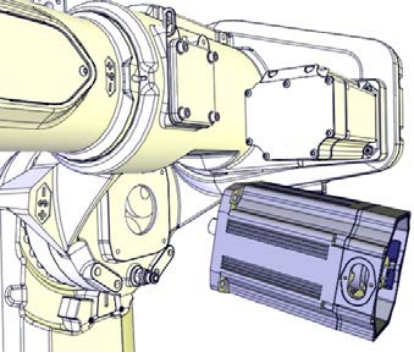
	Action	Note
2	<p> CAUTION</p> <p>The motor weighs 26 kg. All lifting accessories used must be sized accordingly.</p>	
3	<p>Apply the lifting accessories to the motor.</p> <p> Note</p> <p>Make sure the cable gland exit is turned according to figure.</p>	<p>Lifting accessory, motor: 3HAC15534-1</p>  <p>xx1700000273</p>
4	<p>Lift the motor on to the guide pins and let it hang with the outer end a little lower when resting on the guide pins. Do not push the motor pinion into the gear yet.</p> <p>This is done in order to fit the motor with the axis-4 motor still fitted.</p>	 <p>xx1200001131</p>
5	<p>Remove the lifting accessory and allow the motor to rest on the guide pins.</p>	
6	<p>Apply the rotation tool and use it to rotate the pinion when mating it into the gear.</p>	<p>Rotation tool: 3HAB7887-1</p>
7	<p>To release the brakes, connect the 24 VDC power supply.</p> <p>Connect to connector R2.MP3:</p> <ul style="list-style-type: none"> • + = pin 2 • - = pin 5 	

Continues on next page

	Action	Note
8	 CAUTION Whenever parting/mating motor and gearbox, the gears may be damaged if excessive force is used.	
9	Use caution and push the motor in position while at the same time the motor pinion is slightly rotated. Pay attention to following points: <ul style="list-style-type: none"> • Mate the motor pinion properly to the gear of the gearbox. • Do not damage the motor pinion. 	
10	Fit two of the attachment screws and washers.	Screws: M10x30 quality 12.9 Gleitmo
11	Remove the guide pins.	
12	Fit the remaining attachment screws and washers.	Screws: M10x30 quality 12.9 Gleitmo
13	Tighten the screws.	Tightening torque: 50 Nm
14	Remove the rotation tool.	
15	Perform a leak-down test.	See Performing a leak-down test on page 186 .
16	Disconnect the 24 VDC power supply.	

Refitting cable brackets

This procedure is valid if the cabling has been kept installed in the upper arm, when removing the upper arm from the robot. If the cable harness in the upper arm instead has been removed completely, see [Refitting the cable harness - upper arm and wrist on page 256](#).

Use this procedure to refit the cable brackets.

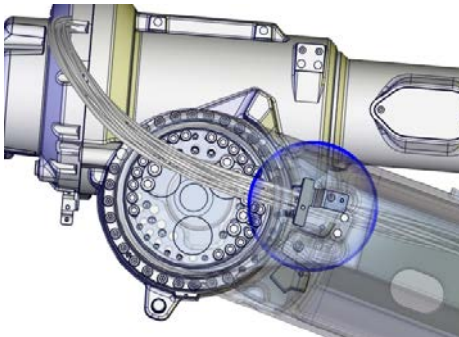

	Action	Note
1	Remove the lifting accessories.	
2	Move the cable harness and DressPack back to the correct side of the robot.	
3	Refit the axis-3 lower arm metal clamp (the one closest to the axis-3 gearbox) located on the inside of the lower arm.  Note The screw is reached from the outside of the lower arm!	 xx180000042

Continues on next page

4 Repair

4.8.5 Replacing the axis-3 gearbox

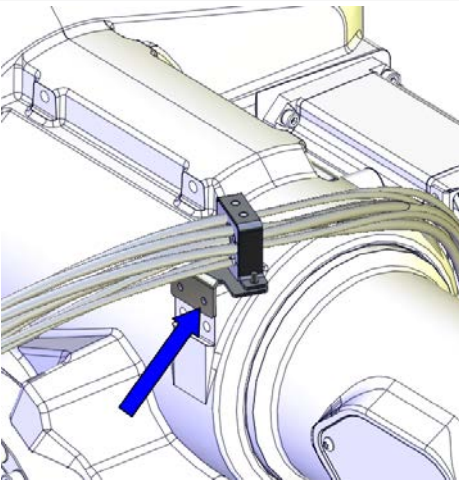
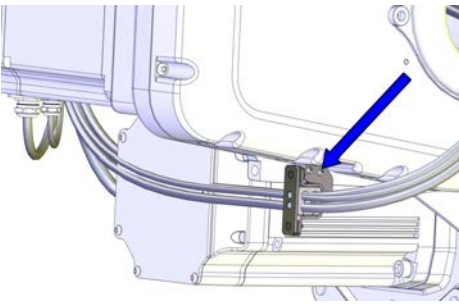
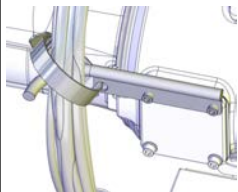
Continued

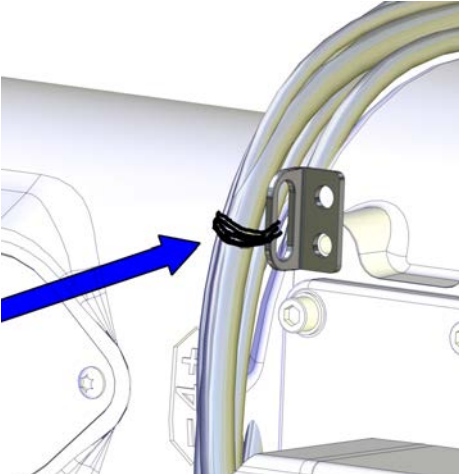
	Action	Note
4	Fasten the cable bracket on top of the arm house.	 xx130000541
5	Fasten the cable bracket under the arm house.	 xx130000543
6	Secure the cable harness to the cable fixing bracket with a cable tie.  xx1300001973	<p> Note If DressPack is fitted, the cable fixing bracket is replaced by the cable guide.</p>  xx130000544

Continues on next page

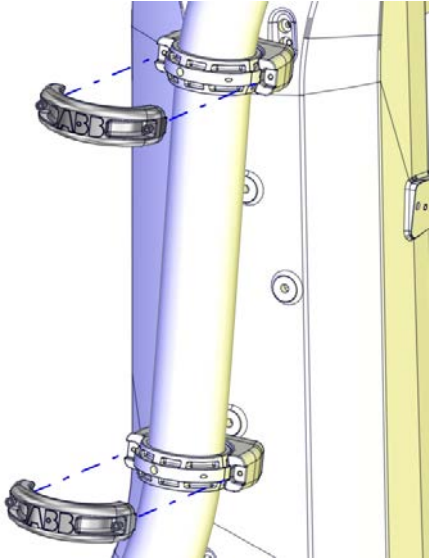
	Action	Note
7	Refit the DressPack cable package into the ball joint housings on the lower arm and close them.	 <p>xx140000195</p>

Connecting the axis-3 and axis-4 motor cables

Use this procedure to connect the motor cables.

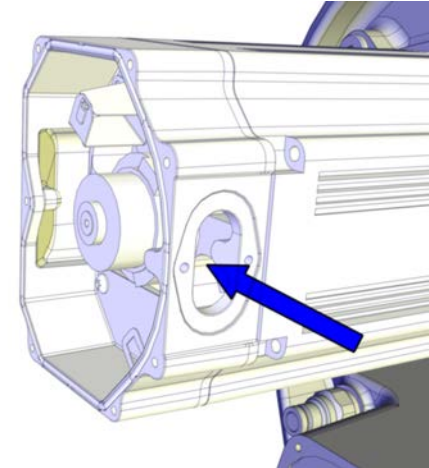

	Action	Note
1	Push the motor cables through the cable gland opening.	 <p>xx130000738</p>

Continues on next page



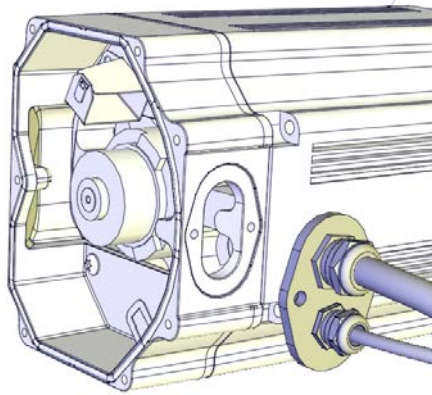
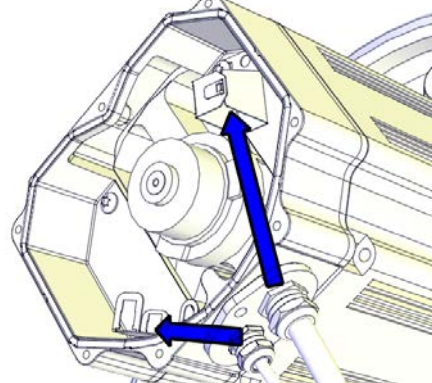

4 Repair

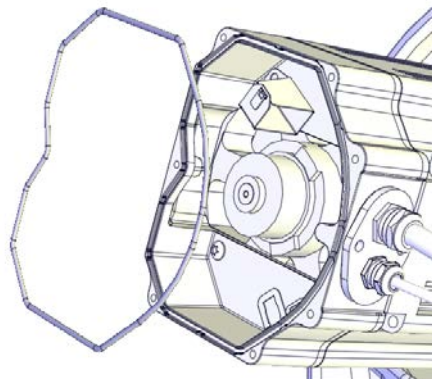
4.8.5 Replacing the axis-3 gearbox

Continued

	Action	Note
2	Refit the cable gland cover.  Note Replace the gasket if damaged.	 xx1200001067
3	Connect the motor cables. Connect in accordance with the markings on the connectors.	 xx1200001066
4	Inspect the o-ring.  Note Replace if damaged.	O-ring, axis-1: 3HAB3772-111 (circular profile) / 3HAC054692-002 (hexagon profile) O-ring, axis-2: 3HAB3772-111 (circular profile) / 3HAC054692-002 (hexagon profile) O-ring, axis-3: 3HAB3772-111 (circular profile) / 3HAC054692-002 (hexagon profile) O-ring, axis-4: 3HAB3772-110 (circular profile) / 3HAC054692-001 (hexagon profile)  xx1200001070

Continues on next page

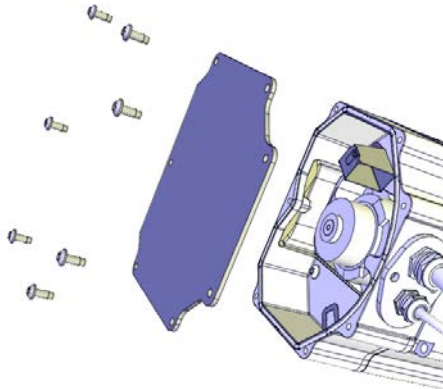
	Action	Note
5	Wipe clean o-ring and o-ring groove.	
6	Refit the o-ring.  Tip Lubricate the o-ring with some grease for a better fitting in the groove.	
7	 CAUTION When fitting the motor cover, make sure that none of the cables inside will be damaged.	
8	Refit the motor cover with it's attachment screws.  Note Do not reuse the self-threading attachment screws. Replace with standard attachment screws or the threads will be damaged.  Note Make sure the o-ring is undamaged and properly fitted.	Attachment screws: M5x12 8.8 (7 pcs)  xx1200001135
9	Make sure that the covers are tightly sealed.	



Refitting DressPack cable packages

	Action	Note
1	Remove the lifting accessory.	

4 Repair

4.8.5 Replacing the axis-3 gearbox

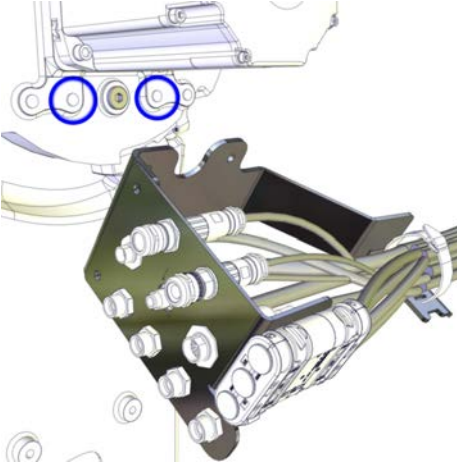
Continued

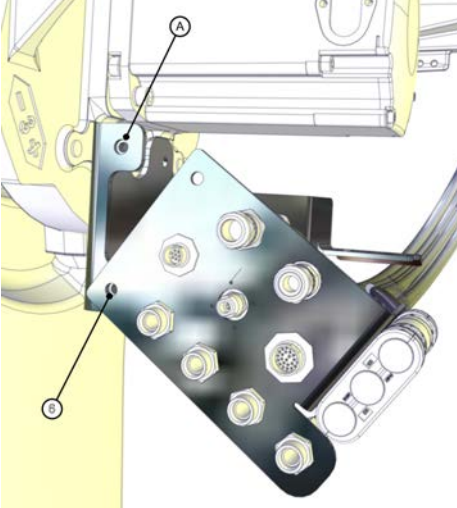
	Action	Note
2	Fit the bracket of the DressPack cable package (if one is fitted) under the arm house with its screws.	 <p>xx1200001332</p>
3	Secure the bracket of the DressPack cable package (if one is fitted) with its attachment screws.  Note It is not needed to disconnect the lower end of the DressPack as the figure shows. Connectors are only hidden here to get a better view of which screw to refit.	 <p>xx1200001331</p> <p>A Removed screw. B Screw unscrewed but not removed.</p>

Concluding procedures

	Action	Note
1	Refill oil in the gearbox.	See Filling oil into the axis-3 gearbox on page 161 .
2	Re-calibrate the robot.	Pendulum Calibration is described in Operating manual - Calibration Pendulum , enclosed with the calibration tools. Axis Calibration is described in Calibrating with Axis Calibration method on page 781 . General calibration information is included in section Calibration on page 767 .
3	 DANGER Make sure all safety requirements are met when performing the first test run.	

4.8.6 Replacing the axis-6 gearbox

Location of the axis-6 gearbox

The axis-6 gearbox is located as shown in the figure.

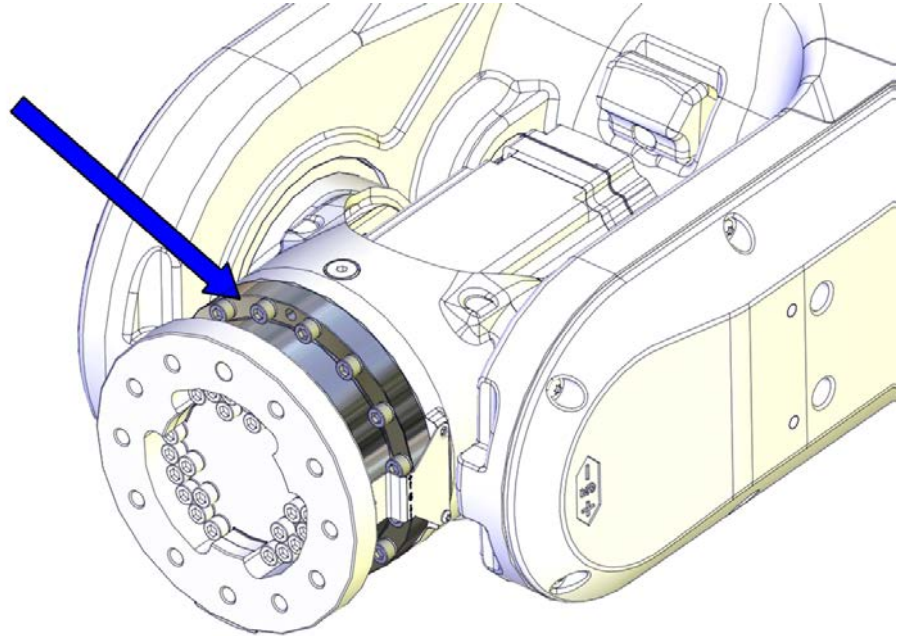

xx130000824

Spare parts

Spare parts	Spare part number	Note
Axis-6 gearbox	See <i>Product manual, spare parts - IRB 6700/IRB 6700Inv.</i> <i>Product manual, spare parts - IRB 6790</i>	

Consumables

Equipment, etc	Article number	Note
Grease	3HAC042536-001	Shell Gadus S2 Used to lubricate o-rings.
O-ring	3HAB3772-107 (IRB 6700 - 235/2.65, IRB 6700 - 205/2.80, IRB 6700 - 175/3.05, IRB 6700 - 150/3.20, IRB 6700 - 300/2.70, IRB 6700 - 245/3.00) 3HAB3772-102 (IRB 6700 - 200/2.60, IRB 6700 - 155/2.85)	D=102x3 Used on motor flange.

Continues on next page

4 Repair

4.8.6 Replacing the axis-6 gearbox

Continued

Equipment, etc	Article number	Note
Gasket	3HAC033489-001/ 3HAC044252-001	Used on motor cover.
O-ring	3HAB3772-58 (IRB 6700 - 235/2.65, IRB 6700 - 205/2.80, IRB 6700 - 175/3.05, IRB 6700 - 150/3.20) 3HAB3772-105 (IRB 6700 - 200/2.60, IRB 6700 - 155/2.85) 3HAB3772-161 (IRB 6700 - 300/2.70, IRB 6700 - 245/3.00)	Used on gearbox.

Required tools and equipment

Equipment, etc.	Article number	Note
Rotation tool	3HAB7887-1	Used to rotate the motor pinion.
24 VDC power supply	-	Used to release the motor brakes.
Leak-down tester	-	
Calibration Pendulum toolkit	3HAC15716-1	Required if Calibration Pendulum is the valid calibration method for the robot.
Calibration tool box, Axis Calibration	3HAC055412-001	Delivered as a set of calibration tools. Required if Axis Calibration is the valid calibration method for the robot.
Standard toolkit	-	Content is defined in section Standard toolkit on page 814 .

Deciding calibration routine

Decide which calibration routine to be used, based on the information in the table. Depending on which routine is chosen, action might be required prior to beginning the repair work of the robot, see the table.

	Action	Note
1	Decide which calibration routine to use for calibrating the robot. <ul style="list-style-type: none"> Reference calibration. External cable packages (DressPack) and tools can stay fitted on the robot. Fine calibration. All external cable packages (DressPack) and tools must be removed from the robot. 	
	<p>If the robot is to be calibrated with reference calibration:</p> <p>Find previous reference values for the axis or create new reference values. These values are to be used after the repair procedure is completed, for calibration of the robot.</p> <p>If no previous reference values exist, and no new reference values can be created, then reference calibration is not possible.</p>	<p>Follow the instructions given in the reference calibration routine on the FlexPendant to create reference values.</p> <p>Creating new values requires possibility to move the robot.</p> <p>Read more about reference calibration for Axis Calibration in Reference calibration routine on page 782.</p> <p>Read more about reference calibration for Pendulum Calibration in Operating manual - Calibration Pendulum.</p>

Continues on next page

	Action	Note
	If the robot is to be calibrated with fine calibration: Remove all external cable packages (DressPack) and tools from the robot.	

Removing the axis-6 gearbox

Use these procedures to remove the axis-6 gearbox.

Preparations before removing the axis-6 gearbox



	Action	Note
1	Decide which calibration routine to use, and take actions accordingly prior to beginning the repair procedure.	
2	 DANGER Turn off all: <ul style="list-style-type: none"> • electric power supply • hydraulic pressure supply • air pressure supply to the robot, before entering the safe-guarded space.	
3	Drain the gearbox.	See Draining the axis-6 gearbox on page 173 .
4	Remove all equipment fitted on the turning disc.	

Continues on next page

4 Repair

4.8.6 Replacing the axis-6 gearbox

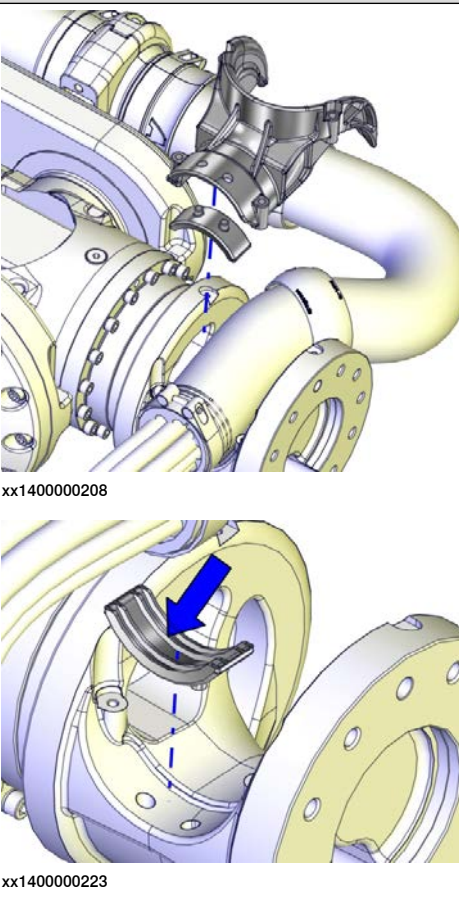
Continued

	Action	Note
5	If installed, remove the DressPack axis-6 support.	 <p>xx140000208</p> <p>xx140000223</p>
6	Jog the robot to: <ul style="list-style-type: none">• Axis 1 = No significance (as long as the robot is secured to the foundation).• Axis 2 = +25°• Axis 3 = +20°• Axis 4 = 0°• Axis 5 = -55°• Axis 6 = -10°	
7	 DANGER Turn off all: <ul style="list-style-type: none">• electric power supply• hydraulic pressure supply• air pressure supply to the robot, before entering the safeguarded space.	

Continues on next page

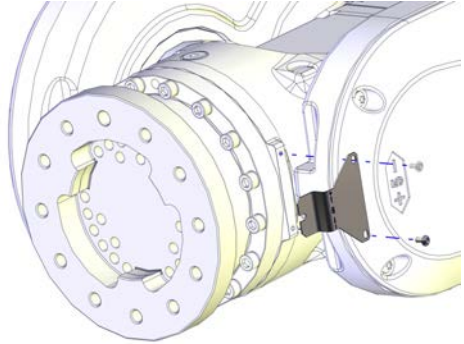
	Action	Note
8	Remove the synchronization plate axis-6.	 <p>xx130000825</p>

Removing the turning disc

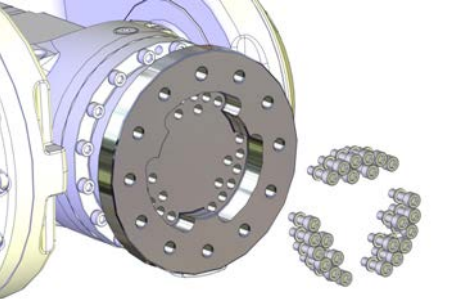
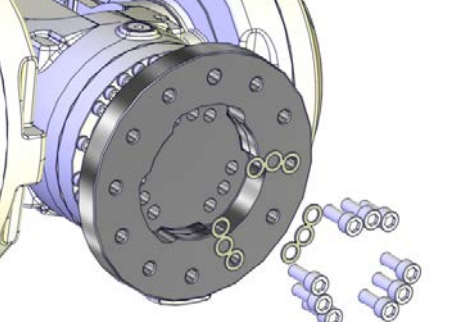
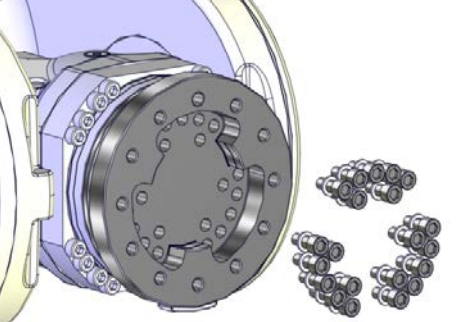
	Action	Note
1	- IRB 6700 - 235/2.65, IRB 6700 - 205/2.80, IRB 6700 - 175/3.05, IRB 6700 - 150/3.20 Remove the screws and washers, that secure the turning disc.	 <p>xx130000492</p>
2	- IRB 6700 - 200/2.60, IRB 6700 - 155/2.85 Remove the screws and washers, that secure the turning disc.	 <p>xx1300002302</p>
3	- IRB 6700 - 300/2.70, IRB 6700 - 245/3.00 Remove the screws and washers, that secure the turning disc.	 <p>xx1400002195</p>

Continues on next page



4 Repair

4.8.6 Replacing the axis-6 gearbox

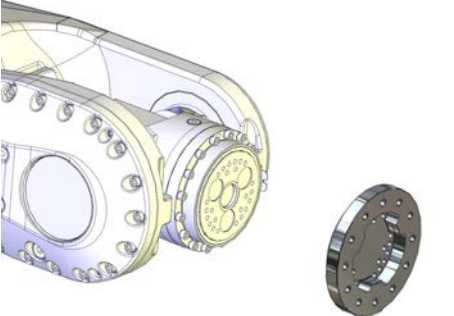
Continued

	Action	Note
4	Remove the turning disc.	 <p data-bbox="943 640 1050 658">xx1300000493</p>

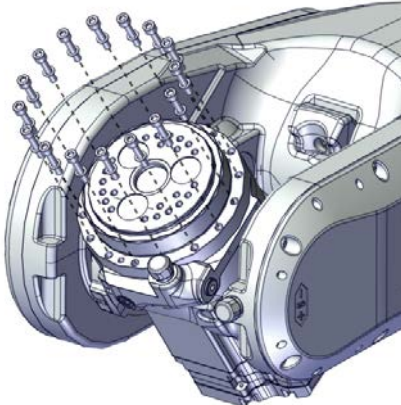
Removing the axis-6 gearbox

	Action	Note
1	Unscrew the attachment screws that secure the axis-6 gearbox.	<ul style="list-style-type: none"> • M8x40 quality 12.9 Gleitmo, 16 pcs (IRB 6700 -235/2.65, -205/2.80, -175/3.05, -150/3.20) • M6x30 quality 12.9 Gleitmo, 24 pcs (IRB 6700 -200/2.60, -155/2.85) • M8x50 quality 12.9 Gleitmo, 16 pcs (IRB 6700 -300/2.70, -245/3.00)  <p data-bbox="943 1480 1050 1498">xx1700001600</p>
2	 CAUTION Whenever parting/mating motor and gearbox, the gears may be damaged if excessive force is used.	

Continues on next page

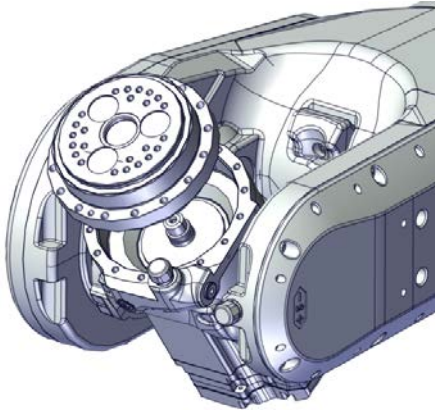

4.8.6 Replacing the axis-6 gearbox
Continued

	Action	Note
3	Remove the gearbox. If required fit two attachment screws and press out the gearbox.	 <p>xx1700001601</p>

Refitting the axis-6 gearbox

Use these procedures to refit the gearbox.

Preparations before refitting the axis-6 gearbox

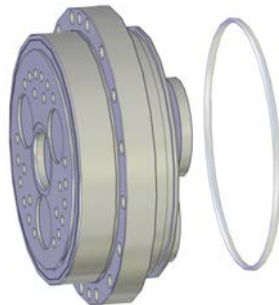
	Action	Note
1	 <p>DANGER</p> <p>Make sure that all supplies for electrical power, hydraulic pressure, and air pressure are turned off.</p>	
2	<p>Ensure a tight fitting of the sealing according to following steps:</p> <ul style="list-style-type: none"> Remove the o-ring and wipe it clean.  <p>Note</p> <p>The o-ring needs to be cleaned also on a new spare part.</p> <ul style="list-style-type: none"> Check the o-ring. Replace if damaged. Wipe clean the contact surfaces from any contamination. Also wipe clean the o-ring groove. Put some grease on the o-ring. Fit the o-ring in the groove of the gearbox. 	<p>O-ring: 3HAB3772-58 (IRB 6700 - 235/2.65, IRB 6700 - 205/2.80, IRB 6700 - 175/3.05, IRB 6700 - 150/3.20) 3HAB3772-105 (IRB 6700 - 200/2.60, IRB 6700 - 155/2.85) 3HAB3772-161 (IRB 6700 - 300/2.70, IRB 6700 - 245/3.00)</p>  <p>xx1300000828</p>

Continues on next page



4 Repair

4.8.6 Replacing the axis-6 gearbox

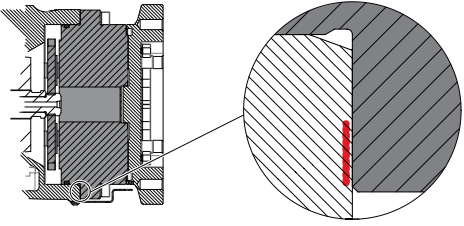
Continued

	Action	Note
3	<p><i>Foundry Plus:</i> Apply Loctite 574 on the surface shown in the figure.</p>	 <p>xx140000717</p>

Refitting the axis-6 gearbox

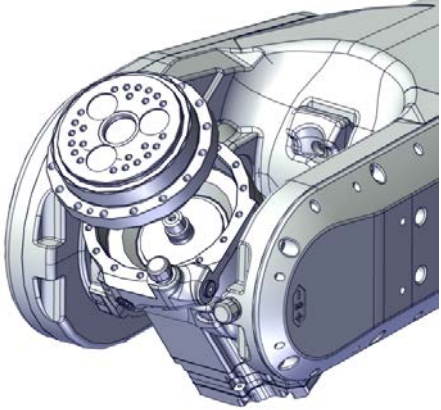
	Action	Note
1	<p> CAUTION</p> <p>Whenever parting/mating motor and gearbox, the gears may be damaged if excessive force is used.</p>	
2	<p>Fit the gearbox to the wrist.</p> <p> CAUTION</p> <p>Be careful not to damage motor pinion or gears!</p>	 <p>xx1700001601</p>

Continues on next page

4.8.6 Replacing the axis-6 gearbox

Continued

Action	Note
3	<p>Secure the gearbox with its attachment screws.</p> <p>Screws:</p> <ul style="list-style-type: none"> • M8x40 quality 12.9 Gleitmo, 16 pcs (IRB 6700 -235/2.65, -205/2.80, -175/3.05, -150/3.20) • M6x30 quality 12.9 Gleitmo, 24 pcs (IRB 6700 -200/2.60, -155/2.85) • M8x50 quality 12.9 Gleitmo, 16 pcs (IRB 6700 -300/2.70, -245/3.00) <p>Tightening torque: 35 Nm (IRB 6700 -235/2.65, -205/2.80, -175/3.05, -150/3.20, -300/2.70, -245/3.00) 14 Nm (IRB 6700 -200/2.60, -155/2.85)</p>  <p style="text-align: right; font-size: small;">xx1700001600</p>
4	<p>Perform a leak-down test.</p> <p>See Performing a leak-down test on page 186.</p>
5	<p>Jog axis-5 to horizontal position.</p>
6	<p>Refill oil in the gearbox.</p> <p>See Filling oil into the axis-6 gearbox on page 175.</p>

Refitting the turning disc

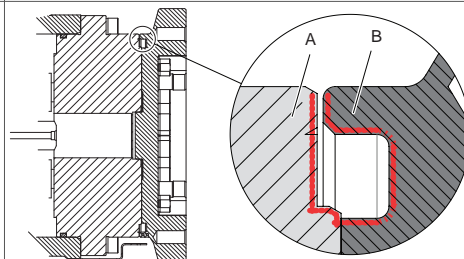
Action	Note
1	<p>If new turning disc spare part is installed: verify that the correct synchronization mark plate for axis-6 is installed on the wrist.</p> <p>See Replacing the synchronization mark plate on page 355.</p>
2	<p>Wipe clean the contact surfaces.</p>
3	<p>Foundry Plus: Apply Mercasol on the surfaces on turning disc and axis-6 gearbox as shown in the figure.</p>  <p style="text-align: right; font-size: small;">xx140000385</p>

Continues on next page

4 Repair

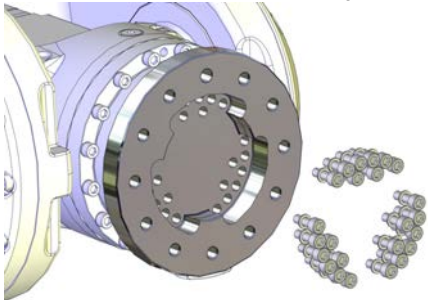
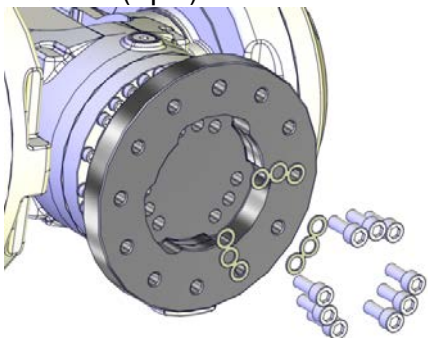
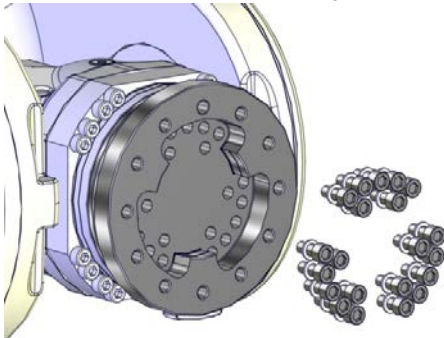

4.8.6 Replacing the axis-6 gearbox

Continued

	Action	Note
4	IRB 6700 - 235/2.65, IRB 6700 - 205/2.80, IRB 6700 - 175/3.05, IRB 6700 - 150/3.20 Secure the turning disc with its attachment screws and washers.	Tightening torque: 35 Nm. Attachment screws: M8x25, Steel 12.9 Gleitmo 603 (24 pcs) Washers: Steel 8.4x13x1.5 (24 pcs)  <small>xx1300000492</small>
5	IRB 6700 - 200/2.60, IRB 6700 - 155/2.85 Secure the turning disc with its attachment screws and washers.	Tightening torque: 70 Nm Attachment screws: M10x25, Steel 12.9 Gleitmo 603, (9 pcs) Washers: (3 pcs)  <small>xx1300002302</small>
6	IRB 6700 - 300/2.70, IRB 6700 - 245/3.00 Secure the turning disc with its attachment screws and washers.	Tightening torque: 70 Nm Attachment screws: M10x25, Steel 12.9 Gleitmo 603, (21 pcs) Washers: Steel 11x17x25 (21 pcs)  <small>xx1400002195</small>

Continues on next page

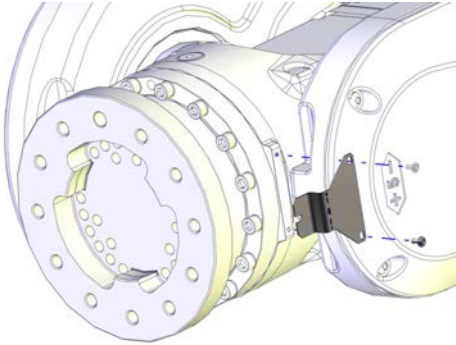
Concluding procedure

	Action	Note
1	Refit the synchronization plate axis-6.	 <p>xx1300000825</p>
2	Re-calibrate the robot.	<p>Pendulum Calibration is described in <i>Operating manual - Calibration Pendulum</i>, enclosed with the calibration tools.</p> <p>Axis Calibration is described in Calibrating with Axis Calibration method on page 781.</p> <p>General calibration information is included in section Calibration on page 767.</p>
3	 <p>DANGER</p> <p>Make sure all safety requirements are met when performing the first test run.</p>	

This page is intentionally left blank

5 Calibration

5.1 Introduction to calibration

5.1.1 Introduction and calibration terminology

Calibration information

This chapter includes general information about the recommended calibration methods and also the detailed procedures for updating the revolution counters, checking the calibration position etc.

Detailed instructions of how to perform Axis Calibration are given on the FlexPendant during the calibration procedure. To prepare calibration with Axis Calibration method, see [Calibrating with Axis Calibration method on page 781](#).

Detailed instructions of how to perform Pendulum Calibration are given in the documentation enclosed with the calibration tools.

Calibration terminology

Term	Definition
Calibration method	A collective term for several methods that might be available for calibrating the ABB robot. Each method contains calibration routines.
Synchronization position	Known position of the complete robot where the angle of each axis can be checked against visual synchronization marks.
Calibration position	Known position of the complete robot that is used for calibration of the robot.
Standard calibration	A generic term for all calibration methods that aim to move the robot to calibration position.
Fine calibration	A calibration routine that generates a new zero position of the robot.
Reference calibration	<p>A calibration routine that in the first step generates a reference to current zero position of the robot. The same calibration routine can later on be used to recalibrate the robot back to the same position as when the reference was stored.</p> <p>This routine is more flexible compared to fine calibration and is used when tools and process equipment are installed.</p> <p>Requires that a reference is created before being used for recalibrating the robot.</p> <p>Requires that the robot is dressed with the same tools and process equipment during calibration as during creation of the reference values.</p>
Update revolution counter	A calibration routine to make a rough calibration of each manipulator axis.
Synchronization mark	Visual marks on the robot axes. When marks are aligned, the robot is in synchronization position.

5 Calibration

5.1.2 Calibration methods

5.1.2 Calibration methods

Overview

This section specifies the different types of calibration and the calibration methods that are supplied by ABB.

Types of calibration

Type of calibration	Description	Calibration method
Standard calibration	<p>The calibrated robot is positioned at calibration position.</p> <p>Standard calibration data is found on the SMB (serial measurement board) or EIB in the robot. For robots with RobotWare 5.04 or older, the calibration data is delivered in a file, calib.cfg, supplied with the robot at delivery. The file identifies the correct resolver/motor position corresponding to the robot home position.</p>	Axis Calibration or Calibration Pendulum ⁱ
Absolute accuracy calibration (optional)	<p>Based on standard calibration, and besides positioning the robot at synchronization position, the Absolute accuracy calibration also compensates for:</p> <ul style="list-style-type: none"> • Mechanical tolerances in the robot structure • Deflection due to load <p>Absolute accuracy calibration focuses on positioning accuracy in the Cartesian coordinate system for the robot.</p> <p>Absolute accuracy calibration data is found on the SMB (serial measurement board) in the robot.</p> <p>For robots with RobotWare 5.05 or older, the absolute accuracy calibration data is delivered in a file, absacc.cfg, supplied with the robot at delivery. The file replaces the calib.cfg file and identifies motor positions as well as absolute accuracy compensation parameters.</p> <p>A robot calibrated with Absolute accuracy has a sticker next to the identification plate of the robot.</p> <p>A robot calibrated with Absolute accuracy has the option information printed on its name plate.</p> <p>To regain 100% Absolute accuracy performance, the robot must be recalibrated for absolute accuracy after repair or maintenance that affects the mechanical structure.</p> <div style="border: 1px solid black; padding: 5px; margin-top: 10px;">  </div> <p>xx0400001197</p>	CalibWare

Continues on next page

Type of calibration	Description	Calibration method
Optimization	<p>Optimization of TCP reorientation performance. The purpose is to improve reorientation accuracy for continuous processes like welding and gluing.</p> <p>Wrist optimization will update standard calibration data for axes 4 and 5.</p>	Wrist Optimization

- ⁱ The robot is calibrated by either Calibration Pendulum or Axis Calibration at factory. Always use the same calibration method as used at the factory. Information about valid calibration method is found on the calibration label or in the calibration menu on the FlexPendant. If no data is found related to standard calibration, contact the local ABB Service.

Brief description of calibration methods

Calibration Pendulum method

Calibration Pendulum is a standard calibration method for calibration of many of ABB robots (except IRB 6400R, IRB 640, IRB 1400H, and IRB 4400S). This calibration method is not used on OmniCore robots.

Two different routines are available for the Calibration Pendulum method:

- Calibration Pendulum II
- Reference calibration

The calibration equipment for Calibration Pendulum is delivered as a complete toolkit, including the *Operating manual - Calibration Pendulum*, which describes the method and the different routines further.

Axis Calibration method

Axis Calibration is a standard calibration method for calibration of IRB 6700. It is the recommended method in order to achieve proper performance.

The following routines are available for the Axis Calibration method:

- Fine calibration
- Update revolution counters
- Reference calibration

The calibration equipment for Axis Calibration is delivered as a toolkit.

An introduction to the calibration method is given in this manual, see [Calibrating with Axis Calibration method on page 781](#).

The actual instructions of how to perform the calibration procedure and what to do at each step is given on the FlexPendant. You will be guided through the calibration procedure, step by step.

Wrist Optimization method

Wrist Optimization is a method for improving reorientation accuracy for continuous processes like welding and gluing and is a complement to the standard calibration method.

The following routines are available for the Wrist Optimization method:

- Wrist Optimization

Continues on next page

5 Calibration

5.1.2 Calibration methods

Continued

The actual instructions of how to perform the calibration procedure and what to do at each step is given on the FlexPendant. You will be guided through the calibration procedure, step by step.

CalibWare - Absolute Accuracy calibration

The CalibWare tool guides through the calibration process and calculates new compensation parameters. This is further detailed in the *Application manual - CalibWare Field*.

If a service operation is done to a robot with the option Absolute Accuracy, a new absolute accuracy calibration is required in order to establish full performance. For most cases after replacements that do not include taking apart the robot structure, standard calibration is sufficient.

The Absolute Accuracy option varies according to the robot mounting position. This is printed on the robot name plate for each robot. The robot must be in the correct mounting position when it is recalibrated for absolute accuracy.

References

Article numbers for the calibration tools are listed in the section [Special tools on page 815](#).

The calibration equipment for Calibration Pendulum is delivered as a complete toolkit, including the *Operating manual - Calibration Pendulum*, which describes the method and the different routines further.

5.1.3 When to calibrate

When to calibrate

The system must be calibrated if any of the following situations occur.

The resolver values are changed

If resolver values are changed, the robot must be re-calibrated using the calibration methods supplied by ABB. Calibrate the robot carefully with standard calibration, according to information in this manual.

If the robot has *absolute accuracy* calibration, it is also recommended, but not always necessary to calibrate for new absolute accuracy.

The resolver values will change when parts affecting the calibration position are replaced on the robot, for example motors or parts of the transmission.

The revolution counter memory is lost

If the revolution counter memory is lost, the counters must be updated. See [Updating revolution counters on page 775](#). This will occur when:

- The battery is discharged
- A resolver error occurs
- The signal between a resolver and measurement board is interrupted
- A robot axis is moved with the control system disconnected

The revolution counters must also be updated after the robot and controller are connected at the first installation.

The robot is rebuilt

If the robot is rebuilt, for example, after a crash or when the reach ability of a robot is changed, it needs to be re-calibrated for new resolver values.

If the robot has *absolute accuracy* calibration, it needs to be calibrated for new absolute accuracy.

5 Calibration

5.2.1 Synchronization marks and synchronization position for axes

5.2 Synchronization marks and axis movement directions

5.2.1 Synchronization marks and synchronization position for axes

Introduction

This section shows the position of the synchronization marks and the synchronization position for each axis.

Synchronization marks, IRB 6700

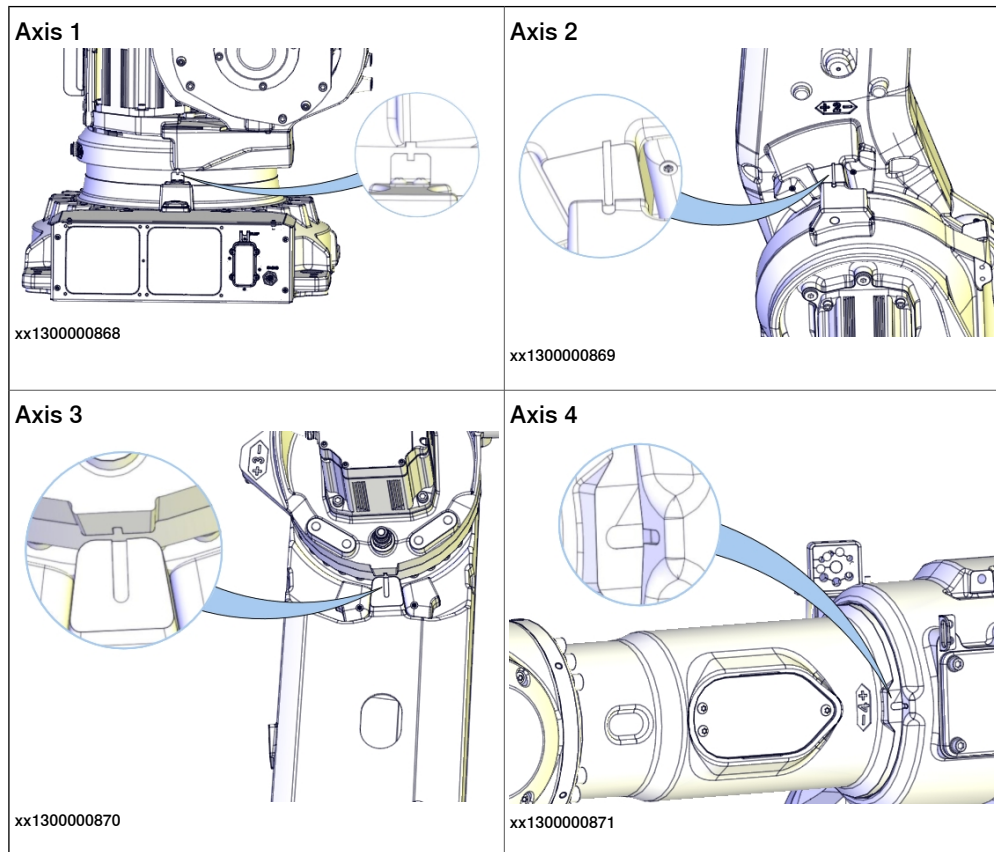

Continues on next page

5.2.1 Synchronization marks and synchronization position for axes

Continued

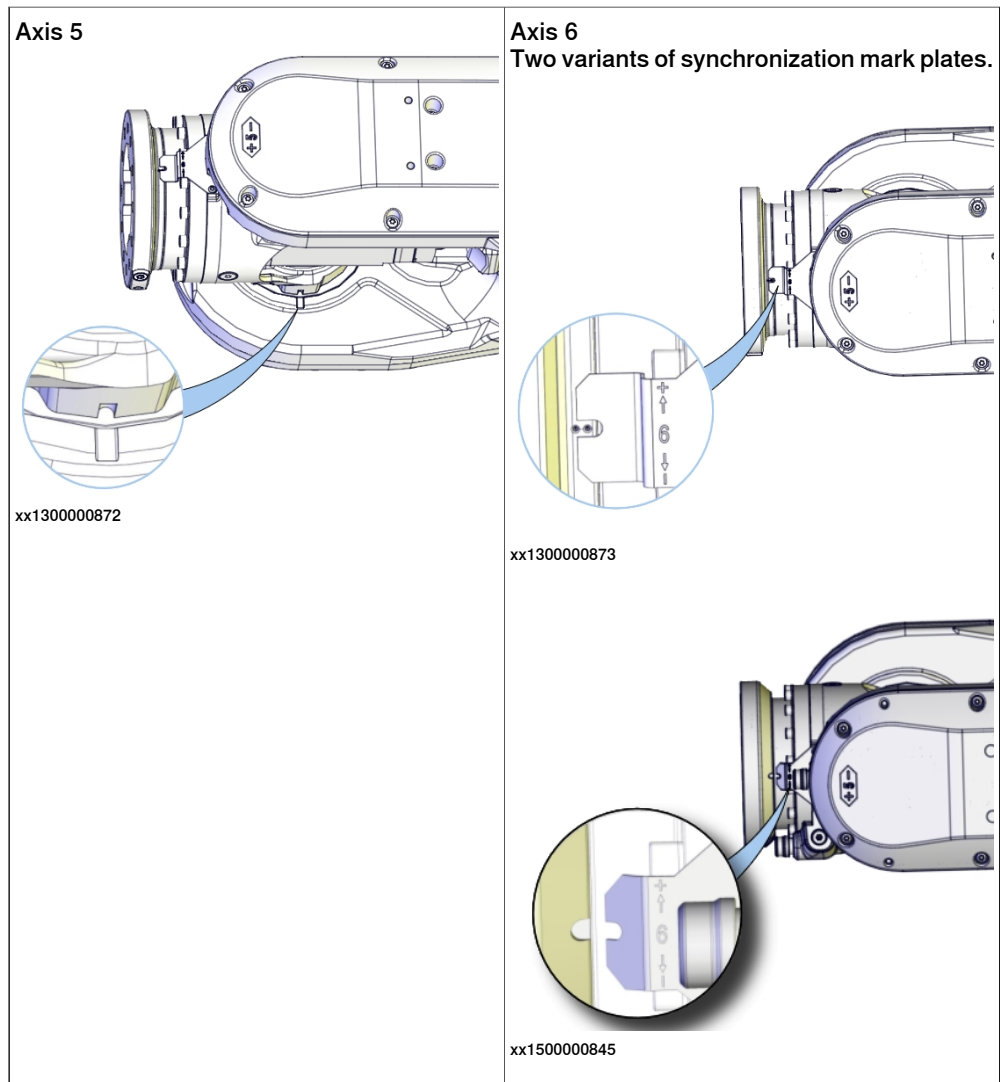

5 Calibration

5.2.2 Calibration movement directions for all axes

5.2.2 Calibration movement directions for all axes

Overview

When calibrating, the axis must consistently be run towards the calibration position in the same direction in order to avoid position errors caused by backlash in gears and so on. Positive directions are shown in the graphic below.

Calibration service routines will handle the calibration movements automatically and these might be different from the positive directions shown below.

Manual movement directions, 6 axes

Note! The graphic shows an IRB 7600. The positive direction is the same for all 6-axis robots, except the positive direction of axis 3 for IRB 6400R, which is in the opposite direction!

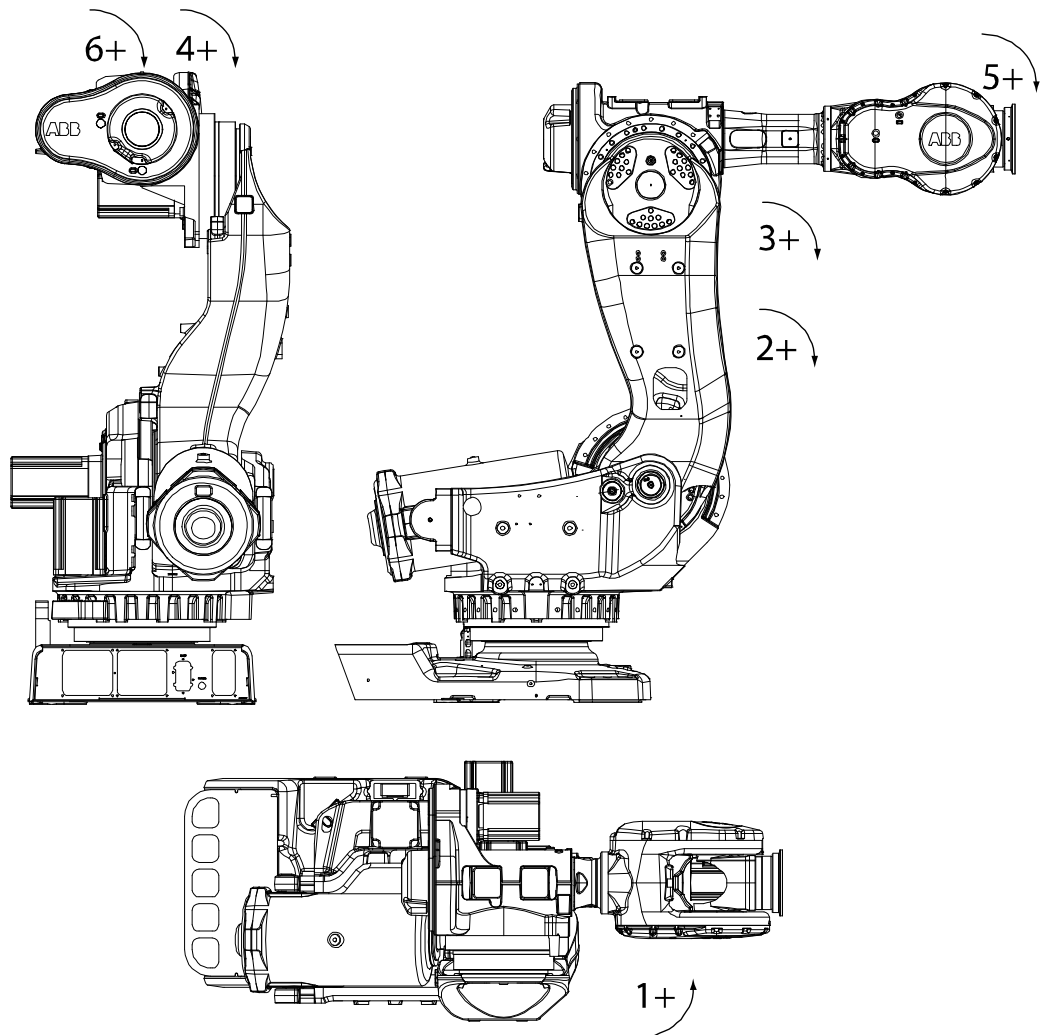

xx020000089

5.3 Updating revolution counters

5.3.1 Updating revolution counters on IRC5 robots

Introduction

This section describes how to do a rough calibration of each manipulator axis by updating the revolution counter for each axis, using the FlexPendant.

Step 1 - Manually running the manipulator to the synchronization position

Use this procedure to manually run the manipulator to the synchronization position.

	Action	Note
1	Select axis-by-axis motion mode.	
2	Jog the manipulator to align the synchronization marks.	See Synchronization marks and synchronization position for axes on page 772 .
3	When all axes are positioned, update the revolution counter.	Step 2 - Updating the revolution counter with the FlexPendant on page 776 .

Correct calibration position of axis 4 and 6

When jogging the manipulator to synchronization position, it is extremely important to make sure that axes 4 and 6 of the following mentioned manipulators are positioned correctly. The axes can be calibrated at the wrong turn, resulting in an incorrect manipulator calibration.

Make sure the axes are positioned according to the correct calibration values, not only according to the synchronization marks. The correct values are found on a label, located either on the lower arm, underneath the flange plate on the base or on the frame.

At delivery the manipulator is in the correct position. Do NOT rotate axis 4 or 6 at power up before the revolution counters are updated.

If one of the following mentioned axes are rotated one or more turns from its calibration position before updating the revolution counter, the correct calibration position will be lost due to non-integer gear ratio. This affects the following manipulators:

Manipulator variant	Axis 4	Axis 6
IRB 6700-235/2.65, -205/2.80, -175/3.05, -150/3.20, -200/2.60, -155/2.85	Yes	No
IRB 6700-300/2.70, -245/3.00	No	No

If the synchronization marks seem to be wrong (even if the motor calibration data is correct), try to rotate the axis one turn, update the revolution counter and check the synchronization marks again (try both directions, if needed).

Continues on next page

5 Calibration

5.3.1 Updating revolution counters on IRC5 robots

Continued

Step 2 - Updating the revolution counter with the FlexPendant

Use this procedure to update the revolution counter with the FlexPendant (IRC5).

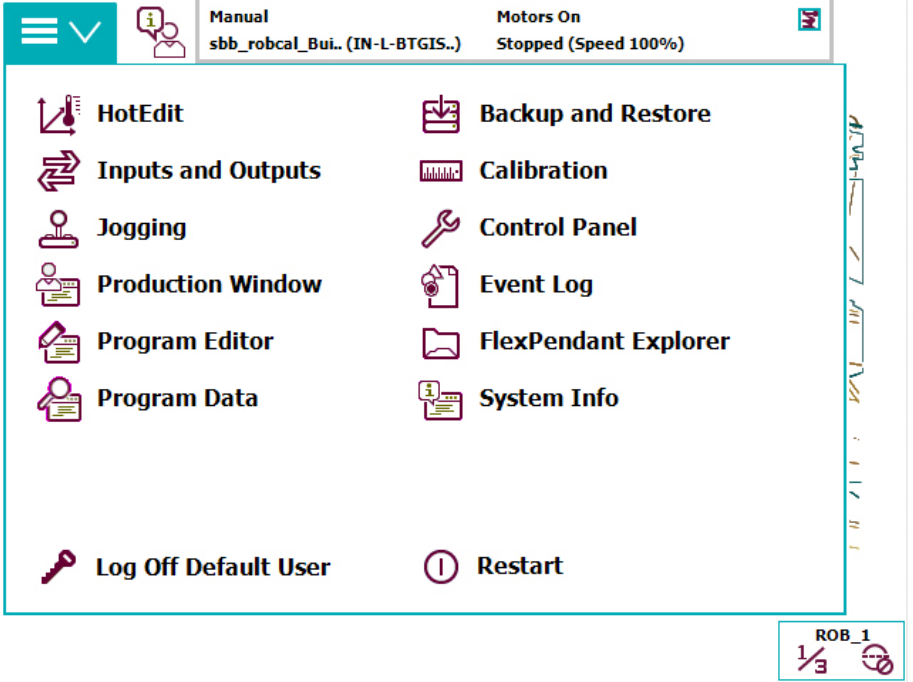
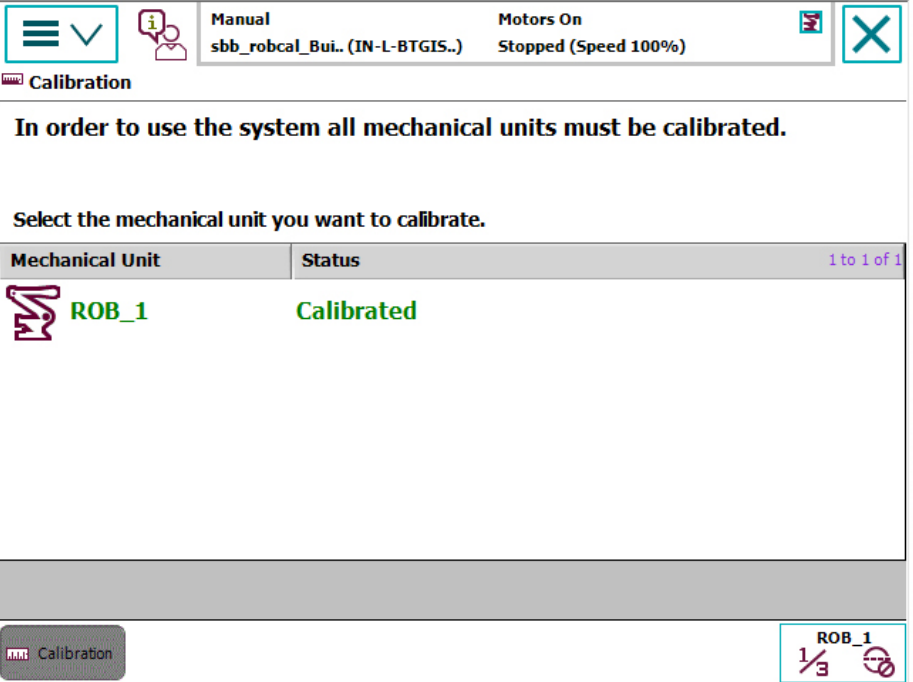
	Action
1	<p>On the ABB menu, tap Calibration.</p>  <p>xx1500000942</p>
2	<p>All mechanical units connected to the system are shown with their calibration status. Tap the mechanical unit in question.</p>  <p>xx1500000943</p>

Continues on next page

Action

3 This step is valid for RobotWare 6.02 and later.
Calibration method used at factory for each axis is shown, as well as calibration method used during last field calibration.
Tap **Manual Method (Advanced)**.

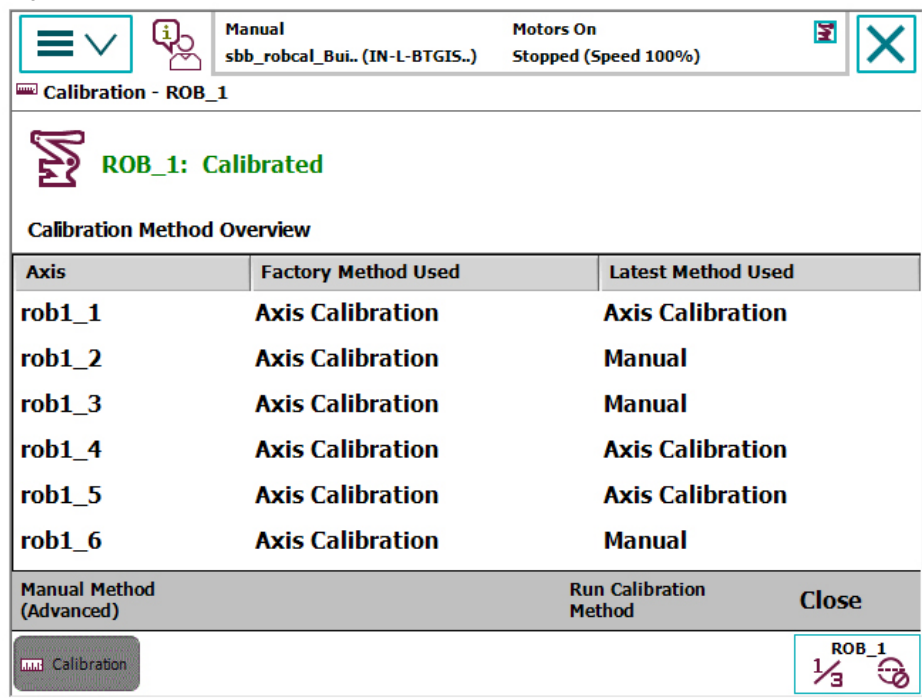

Manual sbb_robcal_Bui.. (IN-L-BTGIS..) Motors On Stopped (Speed 100%)

Calibration - ROB_1

ROB_1: Calibrated

Calibration Method Overview

Axis	Factory Method Used	Latest Method Used
rob1_1	Axis Calibration	Axis Calibration
rob1_2	Axis Calibration	Manual
rob1_3	Axis Calibration	Manual
rob1_4	Axis Calibration	Axis Calibration
rob1_5	Axis Calibration	Axis Calibration
rob1_6	Axis Calibration	Manual

Manual Method (Advanced) Run Calibration Method Close

xx1500000944

4 A screen is displayed, tap **Rev. Counters**.

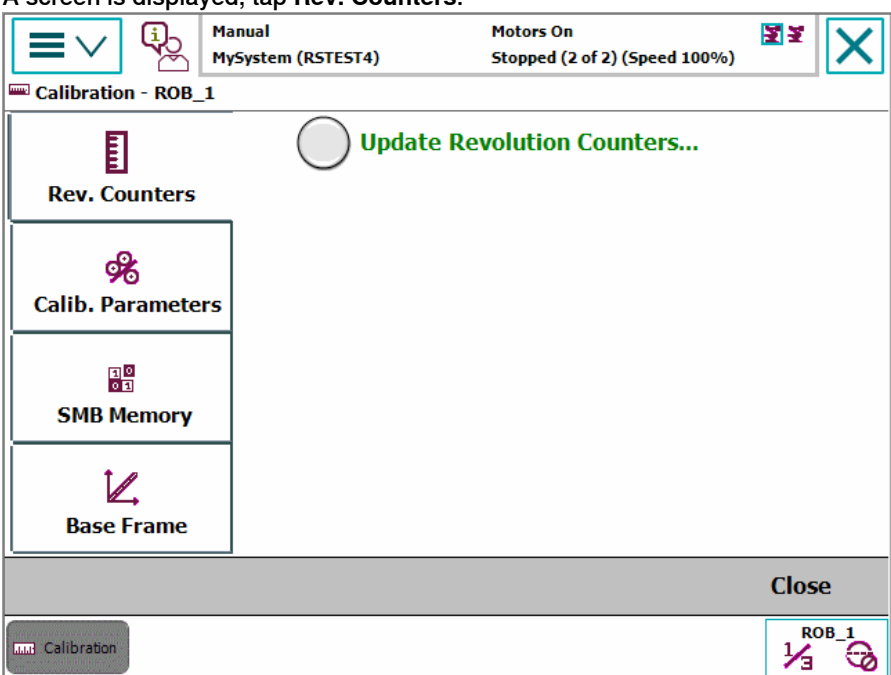

Manual MySystem (RSTEST4) Motors On Stopped (2 of 2) (Speed 100%)

Calibration - ROB_1

Update Revolution Counters...

Rev. Counters

Calib. Parameters

SMB Memory

Base Frame

Close

en0400000771

Continues on next page

5 Calibration

5.3.1 Updating revolution counters on IRC5 robots

Continued

	Action
5	<p>Tap Update Revolution Counters...</p> <p>A dialog box is displayed, warning that updating the revolution counters may change programmed robot positions:</p> <ul style="list-style-type: none">• Tap Yes to update the revolution counters.• Tap No to cancel updating the revolution counters. <p>Tapping Yes displays the axis selection window.</p>
6	<p>Select the axis to have its revolution counter updated by:</p> <ul style="list-style-type: none">• Ticking in the box to the left• Tapping Select all to update all axes. <p>Then tap Update.</p>
7	<p>A dialog box is displayed, warning that the updating operation cannot be undone:</p> <ul style="list-style-type: none">• Tap Update to proceed with updating the revolution counters.• Tap Cancel to cancel updating the revolution counters. <p>Tapping Update updates the selected revolution counters and removes the tick from the list of axes.</p>
8	<p> CAUTION</p> <p>If a revolution counter is incorrectly updated, it will cause incorrect manipulator positioning, which in turn may cause damage or injury!</p> <p>Check the synchronization position very carefully after each update. See Checking the synchronization position on page 797.</p>

5.3.2 Updating revolution counters on OmniCore robots

Introduction

This section describes how to do a rough calibration of each manipulator axis by updating the revolution counter for each axis, using the FlexPendant.



Step 1 - Manually running the manipulator to the synchronization position

Use this procedure to manually run the manipulator to the synchronization position.

	Action	Note
1	Select axis-by-axis motion mode.	
2	Jog the manipulator to align the synchronization marks.	See Synchronization marks and synchronization position for axes on page 772 .
3	When all axes are positioned, update the revolution counter.	Step 2 - Updating the revolution counter with the FlexPendant on page 779 .

Step 2 - Updating the revolution counter with the FlexPendant

Use this procedure to update the revolution counter with the FlexPendant (OmniCore).

	Action
1	On the start screen, tap Calibrate .
2	Select Calibration from the menu. The Mechanical Units page displays a list of available mechanical units.  Note This step is required only if you are not already in the Mechanical Unit page when you open Calibrate .  Note The Mechanical Unit page is displayed only if there are more than one mechanical unit available. Otherwise, the calibration summary page for the available mechanical unit is displayed.
3	Select the mechanical unit for which revolution counter need to be updated.
4	The calibration summary page for the selected mechanical unit is displayed. Calibration method used at factory for each axis is shown, as well as calibration method used during last field calibration.
5	Tap Calibration Methods on the right pane. The calibration options are displayed.
6	Tap Revolution Counters .
7	In the Selection column select the axes for which revolution counters need to be updated.
8	Tap Update . A dialog box is displayed, warning that the updating operation cannot be undone: <ul style="list-style-type: none"> • Tap Update to proceed with updating the revolution counters. • Tap Cancel to cancel updating the revolution counters. Tapping Update and a confirmation window is displayed.

Continues on next page

5 Calibration

5.3.2 Updating revolution counters on OmniCore robots

Continued

Action	
9	Tap OK. The revolution counter for the selected axes is updated.
10	 CAUTION If a revolution counter is incorrectly updated, it will cause incorrect manipulator positioning, which in turn may cause damage or injury! Check the synchronization position very carefully after each update. See Checking the synchronization position on page 797 .

5.4 Calibrating with Axis Calibration method

5.4.1 Description of Axis Calibration

Instructions for Axis Calibration procedure given on the FlexPendant

The actual instructions of how to perform the calibration procedure and what to do at each step is given on the FlexPendant. You will be guided through the calibration procedure, step by step.

This manual contains a brief description of the method, additional information to the information given on the FlexPendant, article number for the tools and images of where to fit the calibration tools on the robot.

Overview of the Axis Calibration procedure

The Axis Calibration procedure applies to all axes, and is performed on one axis at the time. The robot axes are both manually and automatically moved into position, as instructed on the FlexPendant.

A fixed calibration pin/bushing is installed on each robot axis at delivery.

The Axis Calibration procedure described roughly:

- 1 A removable calibration tool is inserted by the operator into a calibration bushing on the axis chosen for calibration, according to instructions on the FlexPendant.



WARNING

Calibrating the robot with Axis Calibration requires special calibration tools from ABB. Using other pins in the calibration bushings may cause severe damage to the robot and/or personnel.



WARNING

The calibration tool must be fully inserted into the calibration bushing, until the steel spring ring snaps into place.

- 2 During the calibration procedure, RobotWare moves the robot axis chosen for calibration so that the calibration tools get into contact. RobotWare records values of the axis position and repeats the coming-in-contact procedure several times to get an exact value of the axis position.



WARNING

Risk of pinching! The contact force for large robots can be up to 150 kg. Keep a safe distance to the robot.

- 3 The axis position is stored in RobotWare with an active choice from the operator.

Continues on next page

5 Calibration

5.4.1 Description of Axis Calibration

Continued

Routines in the calibration procedure

The following routines are available in the Axis Calibration procedure, given at the beginning of the procedure on the FlexPendant.

Fine calibration routine

Choose this routine to calibrate the robot when there are no tools, process cabling or equipment fitted to the robot.

Reference calibration routine

Choose this routine to create reference values and to calibrate the robot when the robot is dressed with tools, process cabling or other equipment.



Note

When calibrating the robot with the reference calibration routine, the robot must be dressed with the same tools, process cabling and any other equipment as when the reference values were created.

If calibrating the robot with reference calibration there must be reference values created before repair is made to the robot, if values are not already available. Creating new values requires possibility to move the robot. The reference values contain positions of all axes, torque of axes and technical data about the tool installed. A benefit with reference calibration is that the current state of the robot is stored and not the state when the robot left the ABB factory. The reference value will be named according to tool name, date etc.

Follow the instructions given in the reference calibration routine on the FlexPendant to create reference values.

When reference calibration is performed, the robot is restored to the status given by the reference values.

Update revolution counters

Choose this routine to make a rough calibration of each manipulator axis by updating the revolution counter for each axis, using the FlexPendant.

Validation

In the mentioned routines, it is also possible to validate the calibration data.

Position of robot axes

The robot axes should be positioned close to 0 degrees before commencing the calibration program. The axis chosen for calibration is then automatically run by the calibration program to its exact calibration position during the calibration procedure.

It is possible to position some of the other axes in positions different from 0 degrees. Information about which axes are allowed to be jogged is given on the FlexPendant.

Continues on next page

These axes are marked with **Unrestricted** in the FlexPendant window. Also the following table shows the dependencies between the axes.

Requirements for axis positioning during calibration

Required position of axis	Axis to calibrate					
	Axis 1	Axis 2	Axis 3	Axis 4	Axis 5	Axis 6
Axis 1	-	*	*	*	*	*
Axis 2	0	-	0	*	*	*
Axis 3	0	0	-	*	*	*
Axis 4	*	*	*	-	*	*
Axis 5	*	*	*	*	-	*
Axis 6	*	*	*	*	*	-

-	Axis to be calibrated
*	Unrestricted. Axis is allowed to be jogged to other position than 0 degrees.
0	Axis must be put in position 0 degrees.

System containing SafeMove

SafeMove will lose its synchronization to the controller if a new calibration is done. New calibration values have to be downloaded to SafeMove, and a new SafeMove calibration has to be done. Make sure that the user rights admit to change the safety settings and to synchronize SafeMove.

For robots with EPS, the same applies as for SafeMove.

5 Calibration

5.4.2 Calibration tools for Axis Calibration

5.4.2 Calibration tools for Axis Calibration

Calibration tool set

The calibration tools used for Axis Calibration are designed to meet requirements for calibration performance, durability and safety in case of accidental damage.

The calibration tool will eventually break from fatigue after longer period of use and then needs to be replaced. There is no risk for bad calibrations as long as the calibration tool is in one piece.



WARNING

Calibrating the robot with Axis Calibration requires special calibration tools from ABB. Using other pins in the calibration bushings may cause severe damage to the robot and/or personnel.

Equipment, etc.	Article number	Note
Calibration tool box, Axis Calibration	3HAC055412-001	Delivered as a set of calibration tools. Required if Axis Calibration is the valid calibration method for the robot.

Examining the calibration tool

Check prior to usage

Before using the calibration tool, make sure that the tube insert, the plastic protection and the steel spring ring are present.



WARNING

If any part is missing or damaged, the tool must be replaced immediately.

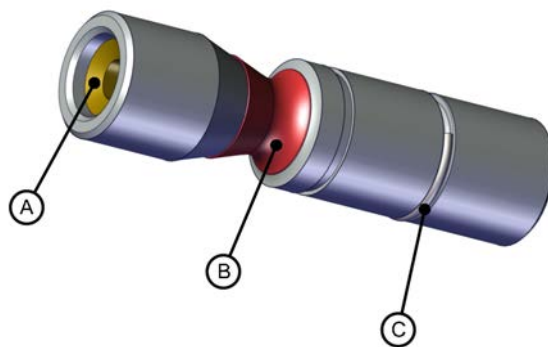

xx1500001914

A	Tube insert
B	Plastic protection
C	Steel spring ring

Continues on next page

Periodic check of the calibration tool

If including the calibration tool in a local periodic check system, the following measures should be checked.

- Outer diameter within $\varnothing 12g4$ mm, $\varnothing 8g4$ mm or $\varnothing 6g5$ mm (depending on calibration tool size).
- Straightness within 0.005 mm.

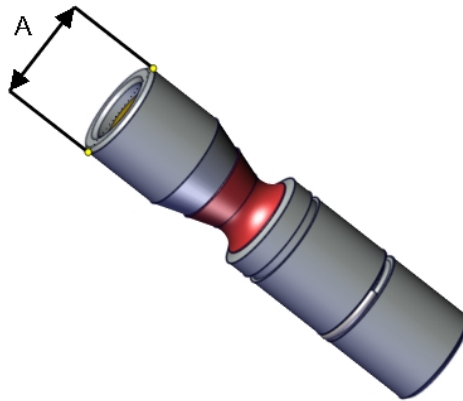

xx150000951

A	Outer diameter
---	----------------

Identifying the calibrating tools

It is possible to make the calibration tool identifiable with, for example, an RFID chip. The procedure of how to install an RFID chip is described below.



Note

The tool identifier is NOT delivered from ABB, it is a customized solution.

	Action	Note
1	<p>It is possible to use any RFID solution, with the correct dimensions. ABB has verified function on some suppliers fulfilling the requirements of NFC compatible devices (13.56 Mhz) according to ISO 14443 or ISO 15693.</p> <div style="margin-top: 10px;"> <p>Note</p> <p>The maximum dimensions on the RFID chip must not exceed $\varnothing 7.9$ mm x 8.0 mm, $\varnothing 5.9$ mm x 8.0 mm or $\varnothing 3.9$ mm x 8.0 mm (depending on calibration tool size).</p> </div>	
2	<p>There is a cavity on one end of the calibration tool in which the RFID chip can be installed.</p> <p>Install the RFID chip according to supplier instructions.</p> <p>Install the chip in flush with the tool end.</p>	

5 Calibration

5.4.3 Installation locations for the calibration tools

5.4.3 Installation locations for the calibration tools

Location of fixed calibration items

This section shows how the robot is equipped with items for installation of calibration tools for Axis Calibration (fixed calibration pins and/or bushings). Installed calibration tools are not shown.

A fixed calibration pin and a bushing for the movable calibration tool are located on each axis as follows.

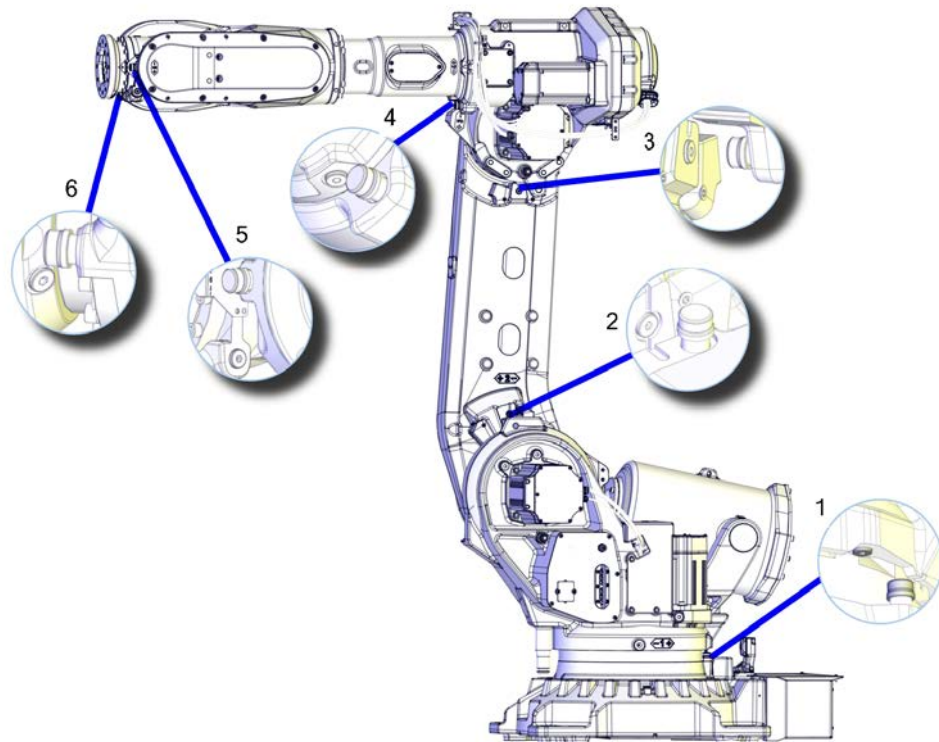

xx150000890

Spare parts

When calibration is not being performed, a protective cover and an o-ring should always be installed on the fixed calibration pin as well as a protective plug, included a sealing, in the bushing. Replace damaged parts with new.

Spare part	Article number	Note
Protection cover and plug set	3HAC056806-001	Contains replacement calibration pin covers and protective plugs for the bushing.

5.4.4 Axis Calibration - Running the calibration procedure

Required tools

The calibration tools used for Axis Calibration are designed to meet requirements for calibration performance, durability and safety in case of accidental damage.



WARNING

Calibrating the robot with Axis Calibration requires special calibration tools from ABB. Using other pins in the calibration holes may cause severe damage to the robot and/or personnel.

Equipment, etc.	Article number	Note
Calibration tool box, Axis Calibration	3HAC055412-001	Delivered as a set of calibration tools. Required if Axis Calibration is the valid calibration method for the robot.

Required consumables

Consumable	Article number	Note
Clean cloth	-	

Spare parts

Spare part	Article number	Note
Protection cover and plug set	3HAC056806-001	Contains replacement calibration pin covers and protective plugs for the bushing.

Overview of the calibration procedure on the FlexPendant

The actual instructions of how to perform the calibration procedure and what to do at each step is given on the FlexPendant. You will be guided through the calibration procedure, step by step.

Use the following list to learn about the calibration procedure before running the RobotWare program on the FlexPendant. It gives you a brief overview of the calibration procedure.

After the calibration method has been started on the FlexPendant, the following sequence will be run.

- 1 Choose calibration routine. The routines are described in [Routines in the calibration procedure on page 782](#).
- 2 Choose which axis/axes to calibrate.
- 3 The robot moves to synchronization position.
- 4 Validate the synchronization marks.
- 5 The robot moves to preparation position.
- 6 Remove the protective cover from the fixed pin and the protection plug from the bushing, if any, and install the calibration tool.

Continues on next page

5 Calibration

5.4.4 Axis Calibration - Running the calibration procedure



Continued

- 7 The robot performs a measurement sequence by rotating the axis back and forth.
- 8 Remove the calibration tool and reinstall the protective cover on the fixed pin and the protection plug in the bushing, if any.
- 9 The robot moves to verify that the calibration tool is removed.
- 10 Choose whether to save the calibration data or not.

Calibration of the robot is not finished until the calibration data is saved, as last step of the calibration procedure.

Preparation prior to calibration

The calibration procedure is described in the FlexPendant while conducting it.

	Action	Note
1	 DANGER While conducting the calibration, the robot needs to be connected to power. Make sure that the robot's working area is empty, as the robot can make unpredictable movements.	
2	Wipe the calibration tool clean.  Note The calibration method is exact. Dust, dirt or color flakes will affect the calibration value.	Use a clean cloth.
3	Check if the standard calibration data for axes 4 or 5 are updated with wrist optimization. This is shown in the calibration overview/summary window on the FlexPendant.	If the data is optimized, the calibration routine Wrist Optimization must be re-run after standard calibration. See Calibrating with Wrist Optimization method on page 794 .

Starting the calibration procedure

Use this procedure to start the Axis Calibration routine on the FlexPendant.

	Action	Note
1	Tap the calibration icon and enter the calibration main page.	
2	All mechanical units connected to the system are shown with their calibration status. Tap the mechanical unit in question.  Note For RobotWare 7, the mechanical unit page is displayed only if there is more than one mechanical unit available.	
3	The calibration method used at ABB factory for each axis is shown, as well as calibration method used for the robot during last field calibration.	The FlexPendant will give all information needed to proceed with Axis Calibration.

Continues on next page

5.4.4 Axis Calibration - Running the calibration procedure

Continued

	Action	Note
4	Valid for RobotWare 6 Tap Call Calibration Method . The software will automatically call for the procedure for the valid calibration method. If not, tap Call Routine and then tap Axis calibration .	
5	Valid for RobotWare 7 Tap Calibration Methods on the right pane and then tap Calibration . The software will automatically call for the procedure for the valid calibration method.	
6	Follow the instructions given on the FlexPendant.	A brief overview of the sequence that will be run on the FlexPendant is given in Overview of the calibration procedure on the FlexPendant on page 787 .

Restarting an interrupted calibration procedure

If the Axis Calibration procedure is interrupted before the calibration is finished, the RobotWare program needs to be started again. Use this procedure to take required action.

Situation	Action
The three-position enabling device on the FlexPendant has been released during robot movement.	Press and hold the three-position enabling device and press Play .
The RobotWare program is terminated with PP to Main .	Remove the calibration tool, if it is installed, and restart the calibration procedure from the beginning. See Starting the calibration procedure . If the calibration tool is in contact the robot axis needs to be jogged in order to release the calibration tool. Jogging the axis in wrong direction will cause the calibration tool to break. Directions of axis movement is shown in Calibration movement directions for all axes on page 774

Axis Calibration with SafeMove option

To be able to run Axis Calibration, SafeMove needs to be unsynchronized. The Axis Calibration routine recognizes if the robot is equipped with SafeMove and will force SafeMove to unsynchronize automatically.

However, SafeMove may generate other warning messages anytime during the Axis Calibration routine. When a warning message is displayed, tap **Acknowledge** to confirm the unsynchronized state and continue Axis Calibration procedure.



CAUTION

SafeMove must be synchronized after the calibration is completed.

Continues on next page

5 Calibration

5.4.4 Axis Calibration - Running the calibration procedure

Continued

After calibration

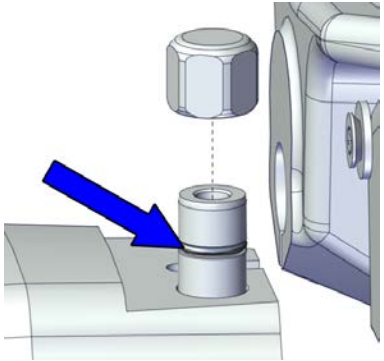
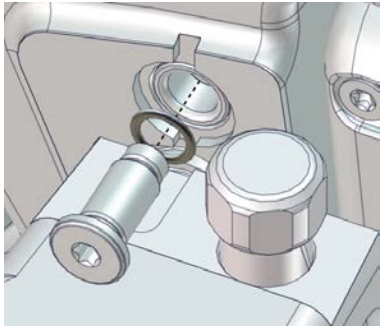
	Action	Note
1	Check the o-ring on the fixed calibration pin. Replace if damaged or missing.	 <p>xx1600002102</p> <p>Protection cover and plug set: 3HAC056806-001.</p>
2	Reinstall the protective cover on the fixed calibration pin on each axis, directly after the axis has been calibrated. Replace the cover with new spare part, if missing or damaged.	
3	Reinstall the protective plug and sealing in the bushing on each axis, directly after the axis has been calibrated. Ensure that the sealing is not damaged. Replace the plug and the sealing with new spare part, if missing or damaged.	 <p>xx1500000952</p> <p>Protection cover and plug set: 3HAC056806-001.</p>
4	If the standard calibration data for axes 4, 5 or 6 should be updated with wrist optimization, run the calibration routine Wrist Optimization .	See Calibrating with Wrist Optimization method on page 794 .

5.4.5 Reference calibration

Brief introduction to Reference Calibration

Reference calibration is a faster method compared to Fine calibration, as it refers to a previously made calibration.

- 1 Create a backup of the current robot system.
- 2 Check that the active calibration offset values corresponds to the values on the silver label (on the lower arm or the base).
- 3 Jog the manipulator so that all axes are in zero position (ex use `MoveAbsJ` instruction). Check that all axis scales are aligned with calibration marks.
- 4 If the scales differ from calibration marks it might depend on wrong turns of the revolution counters. Make a marker line on the corresponding axis to be able to validate the result of the calibration. If more than one motor revolutions are wrong, the calibration will fail.
- 5 Use a verification position. This is especially recommended if all axes were not aligned with the synchronization marks (step 3). Reuse an existing position that is suitable and accurate so it can be used to validate the repair. Use a position where a deviation in axis calibration gives a big deviation in positioning. Note! Check the position after each repair in one axis.
- 6 Use Reference calibration to save reference values for all axes that is to be replaced. Make sure that the values are saved in RobotStudio or FTP program. The files are located in "Active system folder name/HOME/RefCalibFiles".
- 7 Perform the repair.
- 8 Make sure that the tooling and process equipment are the same as when creating the reference. Use Reference calibration to update the system with new calibration offset value for the repaired axis.
- 9 Check the position against the verification position (step 5).
- 10 Proceed with the repair of the next axis, if necessary, and repeat (step 8-9) for every axis.
- 11 (For system containing SafeMove or EPS) Download new calibration values to SafeMove. Use Visual SafeMove in RobotStudio.(For system containing SafeMove) Download new calibration values to SafeMove. Use Visual SafeMove in RobotStudio.
- 12 (For system containing SafeMove or EPS) Synchronize SafeMove to activate SafeMove.(For system containing SafeMove) Synchronize SafeMove to activate SafeMove.
- 13 Perform test run.
- 14 Update the label for resolver values with new calibration values.

Manual tuning of calibration offset

Manual tuning of calibration offset is normally not needed, but can be useful in some situations. The requirement to do manual tuning is that there is a known accurate position, that worked accurately before the repair (step 5, see [Brief introduction to Reference Calibration on page 791](#)).

Continues on next page

5 Calibration

5.4.5 Reference calibration

Continued

Example "Adjust axis 4":

- 1 Create a backup.
- 2 Run the manipulator to the verification position. (The manipulator position is now deviating from the verification position.)
- 3 Read and note current axis 4 value in degrees (example: 96.3 degrees).
- 4 Manually jog, only axis 4, so that the manipulator is correctly positioned to the verification position.
- 5 Read and note current axis 4 value in degrees (example: 94.2 degrees).
- 6 Move the manipulator to its calibration position.
- 7 Calculate the angle difference (ie $96.3 - 94.2 = 2.1$ degrees).
- 8 Manually jog axis 4 the calculated angle difference (-2.1). NOTE! The direction +/- shall be the same direction as the direction used when axis 4 was manually jogged to coincide with the verification process. In the example -2.1 degrees.
- 9 Make a new manual fine calibration of axis 4 with axis in -2.1 degrees position.
- 10 Check again against the verification position.
- 11 Repeat the manual tuning if needed.
- 12 Create a new reference if the intention is to use the reference in the future.

5.5 Calibrating with Calibration Pendulum method

Where to find information for Calibration Pendulum

Detailed instructions of how to perform Pendulum Calibration are given in the documentation enclosed with the calibration tools.

5 Calibration

5.6 Calibrating with Wrist Optimization method

5.6 Calibrating with Wrist Optimization method

When to run Wrist Optimization

Wrist Optimization routine is run to improve TCP reorientation performance.

Calibrating the robot with standard calibration method overwrites the optimized positions of axes 4, 5. Re-run the Wrist Optimization routine after standard calibration to re-achieve the optimized positions of the wrist axes.

Overview of the calibration procedure on the FlexPendant

The actual instructions of how to perform the calibration procedure and what to do at each step is given on the FlexPendant. You will be guided through the calibration procedure, step by step.

Use the following list to learn about the calibration procedure before running the RobotWare program on the FlexPendant. It gives you a brief overview of the calibration procedure sequence.

After the calibration method has been called for on the FlexPendant, the following sequence will be run.

- 1 Choose calibration routine Wrist Optimization.
- 2 Modify targets for 4-point tool frame definition, in Wrist Optimization routine.



Tip

Select positions with large reorientations around the TCP. For best results, make sure that axis 4 and 5 have large movements.

- a Jog the robot to an appropriate position, A, for the first approach point.
Use small increments to accurately position the tool tip as close to the reference point as possible.
- b Tap **Modify Position** to define the point.
- c Repeat for each approach point to be defined, positions B, C, and D.
Jog away from the fixed world point to achieve the best result. Just changing the tool orientation will not give as good a result.

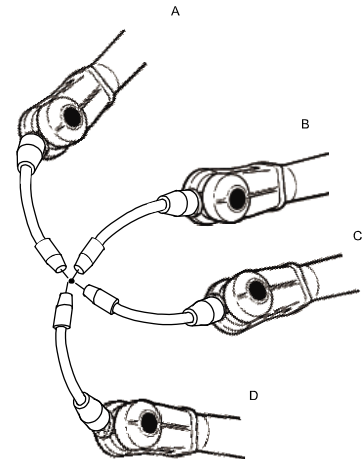

en0400000906

- 3 Improved calibration data to the wrist axes is identified and presented.
- 4 Optimized positions for the wrist axes are presented.

Continues on next page

- 5 The robot moves to the optimized positions for the wrist axes and automatically overwrites previous calibration data.

**WARNING**

Robot moves automatically when pressing **Calibrate**.

- 6 Wrist optimization is finished.
- 7 Redefine / verify TCP for all tools.

5 Calibration

5.7 Verifying the calibration

5.7 Verifying the calibration

Introduction

Always verify the results after calibrating *any* robot axis to verify that all calibration positions are correct.

Verifying the calibration

Use this procedure to verify the calibration result.

	Action	Note
1	Run the calibration home position program twice. Do not change the position of the robot axes after running the program!	See Checking the synchronization position on page 797 .
2	Adjust the <i>synchronization marks</i> when the calibration is done, if necessary.	This is detailed in section Synchronization marks and synchronization position for axes on page 772 .
3	Write down the values on a new label and stick it on top of the calibration label. The label is located on the lower arm.	

5.8 Checking the synchronization position

Introduction

Check the synchronization position of the robot before beginning any programming of the robot system. This may be done:

- Using a `MoveAbsJ` instruction with argument zero on all axes.
- Using the **Jogging** window on the FlexPendant. Using the **Jog** window on the FlexPendant.

Using a `MoveAbsJ` instruction

Use this procedure to create a program that runs all the robot axes to their synchronization position.

	Action	Note
1	On ABB menu tap Program editor .	
2	Create a new program.	
3	Use MoveAbsJ in the Motion&Proc menu.	
4	Create the following program: <pre>MoveAbsJ [[0,0,0,0,0,0], [9E9,9E9,9E9,9E9,9E9,9E9]] \NoEOffs, v1000, fine, tool0</pre>	
5	Run the program in manual mode.	
6	Check that the synchronization marks for the axes align correctly. If they do not, update the revolution counters.	See Synchronization marks and synchronization position for axes on page 772 and Updating revolution counters on page 775 .

Using the jogging window

Use this procedure to jog the robot to the synchronization position of all axes.

	Action	Note
1	On the ABB menu, tap Jogging .	
2	Tap Motion mode to select group of axes to jog.	
3	Tap to select the axis to jog, axis 1, 2, or 3.	
4	Manually run the robots axes to a position where the axis position value read on the FlexPendant, is equal to zero.	
5	Check that the synchronization marks for the axes align correctly. If they do not, update the revolution counters.	See Synchronization marks and synchronization position for axes on page 772 and Updating revolution counters on page 775 .

Continues on next page

5 Calibration

5.8 Checking the synchronization position

Continued

Using a MoveAbsJ instruction

Use this procedure to create a program that runs all the robot axes to their synchronization position.

	Action	Note
1	Tap Code.	
2	Create a new program.	
3	Use MoveAbsJ in the Add Instruction menu.	
4	Create the following program: <pre>MoveAbsJ [[0,0,0,0,0,0], [9E9,9E9,9E9,9E9,9E9,9E9]] \NoEOfs, v1000, fine, tool0</pre>	
5	Run the program in manual mode.	
6	Check that the synchronization marks for the axes align correctly. If they do not, update the revolution counters.	See Synchronization marks and synchronization position for axes on page 772 and Updating revolution counters on page 775 .

Using the jogging window

Use this procedure to jog the robot to the synchronization position of all axes.

	Action	Note
1	Tap Jog.	
2	From the Mechanical unit list select a mechanical unit.	
3	From the Motion mode section, select an axis-set that need to be jogged. For example, to jog axis 2, select the axis set Axis 1-3 .	
4	Follow the screen instruction on joystick movements to understand the direction of the axis that you want to move and move the joystick.	
5	Manually run the robots axes to a position where the axis position value read on the FlexPendant, is equal to zero.	
6	Check that the synchronization marks for the axes align correctly. If they do not, update the revolution counters.	See Synchronization marks and synchronization position for axes on page 772 and Updating revolution counters on page 775 .

6 Decommissioning

6.1 Environmental information

Introduction

ABB robots contain components in different materials. During decommissioning, all materials should be dismantled, recycled, or reused responsibly, according to the relevant laws and industrial standards. Robots or parts that can be reused or upcycled helps to reduce the usage of natural resources.

Symbol

The following symbol indicates that the product must not be disposed of as common garbage. Handle each product according to local regulations for the respective content (see table below).

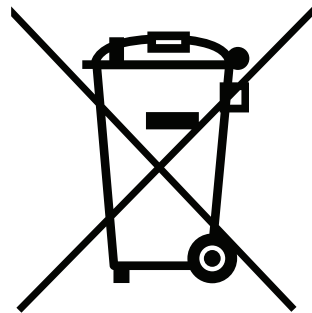

xx180000058

Materials used in the product

The table specifies some of the materials in the product and their respective use throughout the product.

Dispose components properly according to local regulations to prevent health or environmental hazards.

Material	Example application
Aluminium	Covers, synchronization brackets
Batteries, Lithium	Serial measurement board
Cast iron/nodular iron	Base, lower arm, upper arm
Copper	Cables, motors
Neodymium	Brakes, motors
Nickel	Turning disc (foundry)
Oil, grease	Gearboxes
Plastic/rubber	Cables, connectors, drive belts, and so on.
Steel	Gears, screws, base frame, and so on.

Continues on next page

6 Decommissioning

6.1 Environmental information

Continued

Oil and grease

Where possible, arrange for oil and grease to be recycled. Dispose of via an authorized person/contractor in accordance with local regulations. Do not dispose of oil and grease near lakes, ponds, ditches, down drains, or onto soil. Incineration must be carried out under controlled conditions in accordance with local regulations.

Also note that:

- Spills can form a film on water surfaces causing damage to organisms. Oxygen transfer could also be impaired.
- Spillage can penetrate the soil causing ground water contamination.

6.2 Scrapping of robot

Important when scrapping the robot



DANGER

When a robot is disassembled while being scrapped, it is very important to remember the following before disassembling starts, in order to prevent injuries:

- Always remove all batteries. If a battery is exposed to heat, for example from a blow torch, it will explode.
- Always remove all oil/grease in gearboxes. If exposed to heat, for example from a blow torch, the oil/grease will catch fire.
- When motors are removed from the robot, the robot will collapse if it is not properly supported before the motor is removed.

6 Decommissioning

6.3 Decommissioning of balancing device

6.3 Decommissioning of balancing device

General

There is much energy stored in the balancing device. Therefore a special procedure is required to disassemble it. The coil springs inside the balancing device exert a potentially lethal force unless disassembled properly.

The device must be disassembled by a decommissioning company.

Required equipment

Equipment	Article number	Note
Standard toolkit	-	Content is defined in section Standard toolkit on page 814 .
Protective clothing that also covers face and hands	-	Must protect against spatter of sparks and flames.
Cutting torch with a long shaft	-	For opening housing and cutting coils. The long shaft is a safety requirement.
Other tools and procedures may be required. See references to these procedures in the step-by-step instructions below.		These procedures include references to the tools required.



DANGER

Do not, under any circumstances, deal with the balancing device in any other way than that detailed in the product documentation! For example, attempting to open the balancing device is potentially lethal!

Action on field, decommissioning



The procedure below details the actions to perform on field, when the balancing device is to be decommissioned.

	Action	Note
1	Remove the balancing device from the robot.	Detailed in section Replacing the balancing device on page 448 .
2	Send the device to a decommissioning company.	Make sure the decommissioning company is well informed about the stored energy built up by high tensioned compression springs and that the device contains some grease. The following procedure contains useful information about decommissioning.

Continues on next page

Decommissioning at decommissioning company, balancing device

The instruction below details how to decommission the balancing device. Contact ABB Robotics for further consultation.

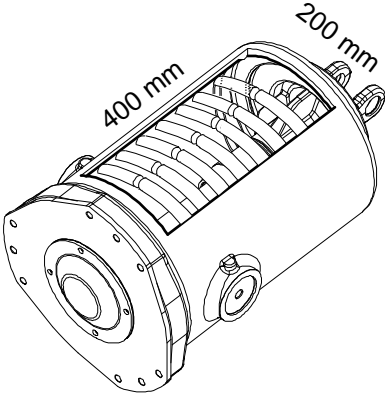
	Action	Note
1	 <p>DANGER</p> <p>There is stored energy built up by high tensioned compression springs inside the balancing device! When a coil is cut the released tension creates a spatter of sparks and flames.</p> <p>The working area must be free of flammable materials. Position the balancing device so that the spatter will be directed away from personnel.</p>	
2	<p>Clamp the device at the working location. Place the device at ground level so that the hole and spring coils are cut from a safe distance and somewhat from above.</p>	
3	 <p>DANGER</p> <p>The hole must be cut as specified in the figure. Pieces of the spring can be thrown out from the cylinder at high speed if the hole is cut larger than specified!</p>	
4	<p>Cut a hole in the housing as shown in the figure.</p>	<p>Use a cutting torch with a long shaft. The measurements shown below are maximum values!</p>  <p>xx0700000391</p>
5	<p>Cut the coils of the springs inside the housing as specified below:</p> <ul style="list-style-type: none"> • Outer spring: cut at least five coils! • Middle spring: cut at least four coils! • Inner spring: cut at least four coils! 	<p>Use a cutting torch with a long shaft.</p>

Continues on next page

6 Decommissioning

6.3 Decommissioning of balancing device

Continued

	Action	Note
6	Double-check the number of coils cut and make sure all the tension in the springs is removed. Double-check the number of coils cut and make sure all the tension in the springs is removed.	

7 Robot description

7.1 Type A vs type B motors

Identifying the motor visually

Type B motors include evacuation on the motor flange to indicate failure of primary sealing between the gearbox and the motor. Robots with protection type Foundry Plus have a sight glass installed in the evacuation holes.

Use the images to identify which type of motor is installed on each robot axis.

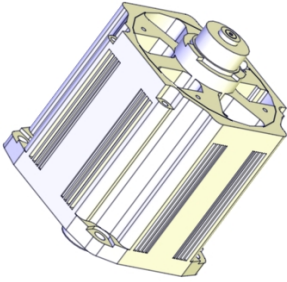
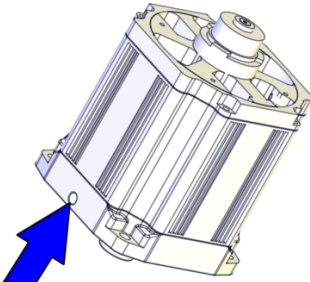
Type A motor	Type B motor
 <p>xx1500001058</p>	 <p>xx1500001057</p>
No evacuation on type A motors.	The type B motor include evacuation on the motor flange.
Attachment holes M14 (axis 1, 2, 3)	Attachment holes M12 (axis 1, 2, 3)

Identifying the motor by article number

Use the table to identify which type of motor is installed on each robot axis by article number. The article numbers specified are found in WebConfig.

Contact ABB Service for further assistance regarding which motor type is installed on the robot, if needed.



Note

The article numbers in the table can not be used for ordering spare parts. The numbers are only used for identification of installed motors.

See *Product manual, spare parts - IRB 6700/IRB 6700Inv* for spare part numbers.

Robot axis	Article number Type A motor	Article number Type B motor	235 /2.65	205 /2.80	175 /3.05	150 /3.20	200 /2.60	155 /2.85	300 /2.70	245 /3.00
1	3HAC045060-001	3HAC055433-001	X	X	X	X	X	X		
	3HAC051321-001	3HAC055442-001							X	X
2	3HAC045061-001	3HAC055434-001	X	X	X	X	X	X		
	3HAC051323-001	3HAC055443-001							X	X
3	3HAC045063-001	3HAC055435-001	X	X	X	X	X	X		
	3HAC051323-001	3HAC055443-001							X	X

Continues on next page

7 Robot description

7.1 Type A vs type B motors

Continued

Robot axis	Article number Type A motor	Article number Type B motor	235 /2.65	205 /2.80	175 /3.05	150 /3.20	200 /2.60	155 /2.85	300 /2.70	245 /3.00
4	3HAC045064-001	3HAC055436-001	X	X	X	X	X	X		
	3HAC045762-001	3HAC055449-001							X	X
5	3HAC045064-001	3HAC055436-001	X	X	X	X	X	X	X	X
6	3HAC045066-001	3HAC055445-001	X	X	X	X			X	X
	3HAC045067-001	3HAC055438-001					X	X		

Interchangeable parts

Use the table to see if type A and type B motors are interchangeable on each robot axis.

Robot axis	Motor replacement from type A to type B	Requirements/notes for replacing type A motor with type B motor
1	Fully interchangeable.	
2	Fully interchangeable.	
3	Fully interchangeable.	
4	Fully interchangeable.	
5	Partly interchangeable.	Replacement to type B requires replacement of the heat protection plates that are fitted to the motor.
6	Interchangeable in a wrist that is manufactured in and after October 2015.	A type B motor does not fit a wrist that is manufactured before October 2015.

8 Reference information

8.1 Introduction

General

This chapter includes general information, complementing the more specific information in the different procedures in the manual.

8 Reference information

8.2 Applicable standards

8.2 Applicable standards

General

The product is compliant with ISO 10218-1:2011, *Robots for industrial environments - Safety requirements - Part 1 Robots*, and applicable parts in the normative references, as referred to from ISO 10218-1:2011. In case of deviation from ISO 10218-1:2011, these are listed in the declaration of incorporation. The declaration of incorporation is part of the delivery.

Robot standards

Standard	Description
ISO 9283	Manipulating industrial robots – Performance criteria and related test methods
ISO 9787	Robots and robotic devices – Coordinate systems and motion nomenclatures
ISO 9946	Manipulating industrial robots – Presentation of characteristics

Other standards used in design

Standard	Description
IEC 60204	Safety of machinery - Electrical equipment of machines - Part 1: General requirements, normative reference from ISO 10218-1
IEC 61000-6-2	Electromagnetic compatibility (EMC) – Part 6-2: Generic standards – Immunity standard for industrial environments
IEC 61000-6-4	Electromagnetic compatibility (EMC) – Part 6-4: Generic standards – Emission standard for industrial environments
ISO 13849-1:2006	Safety of machinery - Safety related parts of control systems - Part 1: General principles for design, normative reference from ISO 10218-1

Region specific standards and regulations

Standard	Description
ANSI/RIA R15.06	Safety requirements for industrial robots and robot systems
ANSI/UL 1740	Safety standard for robots and robotic equipment
CAN/CSA Z 434-03	Industrial robots and robot Systems - General safety requirements
EN ISO 10218-1	Robots and robotic devices — Safety requirements for industrial robots — Part 1: Robots

8.3 Unit conversion

Converter table

Use the following table to convert units used in this manual.

Quantity	Units		
Length	1 m	3.28 ft.	39.37 in
Weight	1 kg	2.21 lb.	
Weight	1 g	0.035 ounces	
Pressure	1 bar	100 kPa	14.5 psi
Force	1 N	0.225 lbf	
Moment	1 Nm	0.738 lbf-ft	
Volume	1 L	0.264 US gal	

8 Reference information

8.4 Screw joints

8.4 Screw joints

General

This section describes how to tighten the various types of screw joints on ABB robots.

The instructions and torque values are valid for screw joints comprised of metallic materials and do *not* apply to soft or brittle materials.

UNBRAKO screws

UNBRAKO is a special type of screw recommended by ABB for certain screw joints. It features special surface treatment (Gleitmo as described below) and is extremely resistant to fatigue.

Whenever used, this is specified in the instructions, and in such cases, *no other type of replacement screw* is allowed. Using other types of screws will void any warranty and may potentially cause serious damage or injury.

Gleitmo treated screws

Gleitmo is a special surface treatment to reduce the friction when tightening the screw joint. It is recommended by ABB for M6-M20 screw joints. Screws treated with Gleitmo may be reused 3-4 times before the coating disappears. After this the screw must be discarded and replaced with a new one.

When handling screws treated with Gleitmo, protective gloves of nitrile rubber type should be used.

Generally, screws are lubricated with *Gleitmo 603* mixed with *Geomet 500* or *Geomet 702* in proportion 1:3. *Geomet* thickness varies according to screw dimensions, refer to the following.

Dimension	Lubricant	Geomet thickness
M6-M20 (any length except M20x60)	<i>Gleitmo 603 + Geomet 500</i>	3-5 µm
M6-M20 (any length except M20x60)	<i>Gleitmo 603 + Geomet 720</i>	3-5 µm
M20x60	<i>Gleitmo 603 + Geomet 500</i>	8-12 µm
M20x60	<i>Gleitmo 603 + Geomet 720</i>	6-10 µm

Screws lubricated in other ways

Screws lubricated with Molykote 1000 or Molykote P1900 should *only* be used when specified in the repair, maintenance or installation procedure descriptions.

In such cases, proceed as follows:

- 1 Apply lubricant to the screw thread.
- 2 Apply lubricant between the plain washer and screw head.
- 3 Screw dimensions of M8 or larger must be tightened with a torque wrench. Screw dimensions of M6 or smaller may be tightened without a torque wrench *if* this is done by trained and qualified personnel.

Continues on next page

Lubricant	Article number
Molykote 1000 (molybdenum disulphide grease)	3HAC042472-001
Molykote P1900 (molybdenum disulphide grease)	3HAC070875-001

Tightening torque

Before tightening any screw, note the following:

- Determine whether a **standard** tightening torque or **special** torque is to be applied. The **standard torques** are specified in the following tables. Any **special torques** are specified in the repair, maintenance or installation procedure descriptions. **Any special torque specified overrides the standard torque!**
- Use the *correct tightening torque* for each type of screw joint.
- Only use *correctly calibrated* torque keys.
- *Always tighten the joint by hand*, and never use pneumatic tools.
- Use the *correct tightening technique*, that is *do not* jerk. Tighten the screw in a slow, flowing motion.
- Maximum allowed total deviation from the specified value is **10%!**

Oil-lubricated screws with slotted or cross-recess head screws

The following table specifies the recommended standard tightening torque for *oil-lubricated screws with slotted or cross-recess head screws*.



Note

A special torque specified in the repair, maintenance or installation procedure overrides the standard torque.

Oil-lubricated screws with allen head screws

The following table specifies the recommended standard tightening torque for *oil-lubricated screws with allen head screws*.



Note

A special torque specified in the repair, maintenance or installation procedure overrides the standard torque.

Dimension	Tightening torque (Nm) Class 8.8, oil-lubricated	Tightening torque (Nm) Class 10.9, oil-lubricated	Tightening torque (Nm) Class 12.9, oil-lubricated
M5	6	-	-
M6	10	-	-
M8	24	34	40
M10	47	67	80
M12	82	115	140
M16	200	290	340
M20	400	560	670

Continues on next page

8 Reference information

8.4 Screw joints

Continued

Dimension	Tightening torque (Nm) Class 8.8, oil-lubricated	Tightening torque (Nm) Class 10.9, oil-lubricated	Tightening torque (Nm) Class 12.9, oil-lubricated
M24	680	960	1150

Lubricated screws (Molykote, Gleitmo or equivalent) with allen head screws

The following table specifies the recommended standard tightening torque for *screws lubricated with Molykote 1000, Gleitmo 603 or equivalent with allen head screws*.



Note

A special torque specified in the repair, maintenance or installation procedure overrides the standard torque.

Dimension	Tightening torque (Nm) Class 10.9, lubricated ⁱ	Tightening torque (Nm) Class 12.9, lubricated ⁱ
M8	28	35
M10	55	70
M12	96	120
M16	235	300
M20	460	550
M24	790	950

ⁱ Lubricated with Molykote 1000, Gleitmo 603 or equivalent

Water and air connectors

The following table specifies the recommended standard tightening torque for *water and air connectors* when *one or both* connectors are made of *brass*.



Note

A special torque specified in the repair, maintenance or installation procedure overrides the standard torque.

Dimension	Tightening torque Nm - Nominal	Tightening torque Nm - Min.	Tightening torque Nm - Max.
1/8	12	8	15
1/4	15	10	20
3/8	20	15	25
1/2	40	30	50
3/4	70	55	90

8.5 Weight specifications

Definition

In installation, repair, and maintenance procedures, weights of the components handled are sometimes specified. All components exceeding 22 kg (50 lbs) are highlighted in this way.

To avoid injury, ABB recommends the use of a lifting accessory when handling components with a weight exceeding 22 kg. A wide range of lifting accessories and devices are available for each manipulator model.

Example

Following is an example of a weight specification in a procedure:

Action	Note
 CAUTION The arm weighs 25 kg. All lifting accessories used must be sized accordingly.	

8 Reference information

8.6 Standard toolkit

8.6 Standard toolkit

General

All service (repairs, maintenance, and installation) procedures contains lists of tools required to perform the specified activity.

All special tools required are listed directly in the procedures while all the tools that are considered standard are gathered in the standard toolkit and defined in the following table.

This way, the tools required are the sum of the standard toolkit and any tools listed in the instruction.

Contents, standard toolkit

Qty	Tool	Comment
1	Ring-open-end spanner 8-19 mm	
1	Socket head cap 2.5-17 mm	
1	Torx socket no: 20-60	
1	Box spanner set	
1	Torque wrench 10-100 Nm	
1	Torque wrench 75-400 Nm	
1	Ratchet head for torque wrench 1/2	
2	Hexagon-headed screw M10x100	
1	Hexagon-headed screw M16x90	
1	Hex bit socket head cap no. 14 socket 40 mm L=100 mm	
1	Hex bit socket head cap no. 14 socket 40 mm L=20 mm	To be shortened to 12 mm
1	Hex bit socket head cap no. 6 socket 40 mm L=145 mm	
1	Hex bit socket head cap no. 6 socket 40mm bit L=220 mm	
1	Plastic mallet	

8.7 Special tools

General





All service instructions contain lists of tools required to perform the specified activity. The required tools are a sum of standard tools, defined in the section [Standard toolkit on page 814](#), and of special tools, listed directly in the instructions and also gathered in this section.

Special tools

Continues on next page

8 Reference information

8.7 Special tools

Tools and equipment with spare part number: (These tools can be ordered from ABB)		Cable harness	SMB	Brake release unit	Lower arm	Upper arm	Wrist	Turning disc	Balancing device	Spherical roller bearing (link ear)	Rear bearing (balancing device)	Axis 1 motor	Axis 2 motor	Axis 3 motor	Axis 4 motor	Axis 5 motor	Axis 6 motor	Axis 1 gearbox	Axis 2 gearbox	Axis 3 gearbox	Axis 6 gearbox
Guide pins																					
3HAC15520-1	Guide pin, M8x100															2					
3HAC15521-2	Guide pin, M10x150											2 ⁱ	2 ⁱ	2 ⁱ	2			2	2	2	
3HAC13056-2	Guide pin, M12x150				x	x	2					2 ⁱ	2 ⁱ	2 ⁱ					x	x	
3HAC13056-3	Guide pin, M12x200				x	x												x	x	x	
3HAC13120-2	Guide pin, M16x150				x													x	x		
3HAC13120-3	Guide pin, M16x200				x													x	x		
Lifting accessories																					
3HAC15556-1	Lifting accessory (chain)				x	x								x				x	x	x	
																					
					xx1200001241																
3HAC14459-1	Lifting accessory, motor											x						x			
3HAC15534-1	Lifting accessory, motor												x	x					x		
3HAC046112-001	Lifting accessory, gearbox																		x		
3HAC046128-001 ⁱⁱⁱ 3HACxx ^{iv} 3HAC046112-001 ^v	Lifting accessory, gearbox																				x
3HAC16131-1	Lifting eye M12				2	2												2	2	2	
																					
					xx1200001242																
3HAC14457-4	Lifting eye M16																	2	x		
																					
					xx1200001242																
-	Lifting shackle SA-10-8-NA1				x				x	x	x								x		
																					
					xx1200001243																

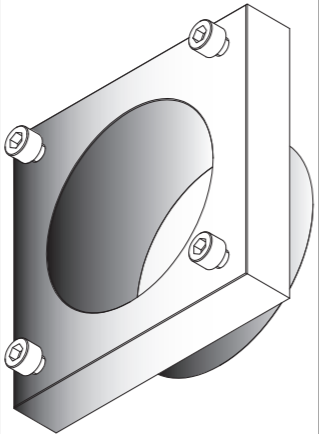
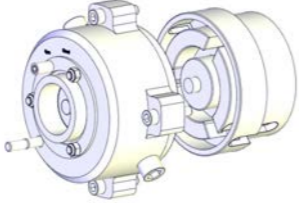

Continues on next page

Tools and equipment with spare part number: (These tools can be ordered from ABB)		Cable harness	SMB	Brake release unit	Lower arm	Upper arm	Wrist	Turning disc	Balancing device	Spherical roller bearing (link ear)	Rear bearing (balancing device)	Axis 1 motor	Axis 2 motor	Axis 3 motor	Axis 4 motor	Axis 5 motor	Axis 6 motor	Axis 1 gearbox	Axis 2 gearbox	Axis 3 gearbox	Axis 6 gearbox	
-	Fender washer Outer diameter: minimum 26 mm, maximum 30 mm, hole diameter: 13 mm, thickness: 3 mm.				x	x												x	x	x		
-	Roundsling, 1.5 m Length: 1.5 m. Lifting capacity: 2,000 kg.				x													x	x			
-	Roundsling, 1 m Length: 1 m, lifting capacity: 1,000 kg.				x		x		x	x	x	x	x	x				x	x			
3HAC047054-003	Fork lift accessory set				x				x		x							x	x			
Press, puller and unloading tools																						
3HAC12475-6	AdapterM20-M16				x				x											x		
3HAC028920-001	Dismantle and mounting tool				x				x	x	x									x		
3HAC030662-001	Distance tool				x					x	x									x		
		 xx1400000726																				
3HAC020902-001	Hydraulic press tool, balancing device								x													
		 xx1300000672																				
3HAC11731-1	Hydraulic cylinder								x	x	x									x		
3HAC13086-1	Hydraulic pump 80 MPa								x	x	x									x		
-	Threaded bar, M16x340				x				x		x									x		

Continues on next page

8 Reference information

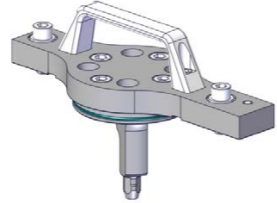
8.7 Special tools

Tools and equipment with spare part number: (These tools can be ordered from ABB)		Cable harness	SMB	Brake release unit	Lower arm	Upper arm	Wrist	Turning disc	Balancing device	Spherical roller bearing (link ear)	Rear bearing (balancing device)	Axis 1 motor	Axis 2 motor	Axis 3 motor	Axis 4 motor	Axis 5 motor	Axis 6 motor	Axis 1 gearbox	Axis 2 gearbox	Axis 3 gearbox	Axis 6 gearbox
Removal tools																					
-	Screws M8x75, fully threaded																				3
3HAC057339-002	Removal tool kit M12 and M14											x ⁱ	x ⁱ	x ⁱ	x	x	x				
3HAC057339-002	Removal tool kit M12 and M14											x ⁱ	x ⁱ	x ⁱ				x	x		
Other tools																					
-	24 VDC power supply				x	x	x					x	x	x	x	x	x	x	x	x	x
3HAC046645-003	Aligning tool																	x			
	 xx1700001659																				
-	Long AllenKeySocketIN19L 6-140														x	x	x				
3HAC12342-1	Bits extender											x	x	x				x	x		
3HAC15716-1	Calibration Pendulum toolkit ^{vii}				x	x	x	x				x	x	x	x	x	x	x	x	x	x
3HAC055412-001	Calibration tool box, Axis Calibration ^{vii}				x	x	x	x				x	x	x	x	x	x	x	x	x	x
3HAC043870-009	Guide for reduction gear																	x			
	 xx1700002195																				
-	Leak-down tester											x	x	x	x	x	x	x	x	x	x
-	Lock screw, M16x120								x	x	x		x								
-	Oil collecting vessel												x	x				x	x	x	x
-	Oil dispenser												x	x				x	x	x	x

Continues on next page

Tools and equipment with spare part number: (These tools can be ordered from ABB)			Cable harness	SMB	Brake release unit	Lower arm	Upper arm	Wrist	Turning disc	Balancing device	Spherical roller bearing (link ear)	Rear bearing (balancing device)	Axis 1 motor	Axis 2 motor	Axis 3 motor	Axis 4 motor	Axis 5 motor	Axis 6 motor	Axis 1 gearbox	Axis 2 gearbox	Axis 3 gearbox	Axis 6 gearbox	
3HAC067546-001 ^{viii} 3HAC067547-001 ^{ix} 3HAC067545-001 ^x	Pinion	 xx1800001147																				x	
3HAB7887-1	Rotation tool					x	x						x	x	x	x	x	x	x	x	x	x	x

- ⁱ Tool depending on motor types. See [Type A vs type B motors on page 805](#).
IRB 6700 - 235/2.65, IRB 6700 - 205/2.80, IRB 6700 - 175/3.05, IRB 6700 - 150/3.20, IRB 6700 - 200/2.60, IRB 6700 - 155/2.85
- ⁱⁱⁱ IRB 6700 - 235/2.65, IRB 6700 - 205/2.80, IRB 6700 - 175/3.05, IRB 6700 - 150/3.20
- ^{iv} IRB 6700 - 200/2.60, IRB 6700 - 155/2.85
- ^v IRB 6700 - 300/2.70, IRB 6700 - 245/3.00
Included in Dismantle and mounting tool (3HAC028920-001).
- ^{vii} The robot is calibrated by either Calibration Pendulum or Axis Calibration at factory. Always use the same calibration method as used at the factory.
Information about valid calibration method is found on the calibration label or in the calibration menu on the FlexPendant.
- ^{viii} IRB 6700 - 235/2.65, IRB 6700 - 205/2.80, IRB 6700 - 175/3.05, IRB 6700 - 150/3.20
- ^{ix} IRB 6700 - 200/2.60, IRB 6700 - 155/2.85
- ^x IRB 6700 - 300/2.70, IRB 6700 - 245/3.00

Continues on next page

8 Reference information

8.8 Lifting accessories and lifting instructions

8.8 Lifting accessories and lifting instructions

General

Many repair and maintenance activities require different pieces of lifting accessories, which are specified in each procedure.

The use of each piece of lifting accessories is *not* detailed in the activity procedure, but in the instruction delivered with each piece of lifting accessories.

The instructions delivered with the lifting accessories should be stored for later reference.

9 Spare parts

9.1 Spare part lists and illustrations

Location

Spare parts and exploded views are not included in the manual but delivered as a separate document for registered users on myABB Business Portal, www.abb.com/myABB.



Tip

All documents can be found via myABB Business Portal, www.abb.com/myABB.

This page is intentionally left blank

10 Circuit diagrams

10.1 Circuit diagrams

Overview

The circuit diagrams are not included in this manual, but are available for registered users on myABB Business Portal, www.abb.com/myABB.

See the article numbers in the tables below.

Controllers

Product	Article numbers for circuit diagrams
<i>Circuit diagram - OmniCore V250XT</i>	<i>3HAC074000-008</i>
<i>Circuit diagram - IRC5</i>	<i>3HAC024480-011</i>
<i>Circuit diagram - IRC5 Panel Mounted Controller</i>	<i>3HAC026871-020</i>
<i>Circuit diagram - Euromap 67, design 14</i>	<i>3HAC024120-005</i>
<i>Circuit diagram - Spot welding cabinet</i>	<i>3HAC057185-001</i>

Manipulators

Product	Article numbers for circuit diagrams
<i>Circuit diagram - IRB 120</i>	<i>3HAC031408-003</i>
<i>Circuit diagram - IRB 140 type C</i>	<i>3HAC6816-3</i>
<i>Circuit diagram - IRB 260</i>	<i>3HAC025611-001</i>
<i>Circuit diagram - IRB 360</i>	<i>3HAC028647-009</i>
<i>Circuit diagram - IRB 460</i>	<i>3HAC036446-005</i>
<i>Circuit diagram - IRB 660</i>	<i>3HAC025691-001</i>
<i>Circuit diagram - IRB 760</i>	<i>3HAC025691-001</i>
<i>Circuit diagram - IRB 1200</i>	<i>3HAC046307-003</i>
<i>Circuit diagram - IRB 1410</i>	<i>3HAC2800-3</i>
<i>Circuit diagram - IRB 1600/1660</i>	<i>3HAC021351-003</i>
<i>Circuit diagram - IRB 1520</i>	<i>3HAC039498-007</i>
<i>Circuit diagram - IRB 2400</i>	<i>3HAC6670-3</i>
<i>Circuit diagram - IRB 2600</i>	<i>3HAC029570-007</i>
<i>Circuit diagram - IRB 4400/4450S</i>	<i>3HAC9821-1</i>
<i>Circuit diagram - IRB 4600</i>	<i>3HAC029038-003</i>
<i>Circuit diagram - IRB 6620</i>	<i>3HAC025090-001</i>
<i>Circuit diagram - IRB 6620 / IRB 6620LX</i>	<i>3HAC025090-001</i>
<i>Circuit diagram - IRB 6640</i>	<i>3HAC025744-001</i>
<i>Circuit diagram - IRB 6650S</i>	<i>3HAC13347-1</i> <i>3HAC025744-001</i>

Continues on next page

10 Circuit diagrams

10.1 Circuit diagrams

Continued

Product	Article numbers for circuit diagrams
<i>Circuit diagram - IRB 6660</i>	<i>3HAC025744-001 3HAC029940-001</i>
<i>Circuit diagram - IRB 6700 / IRB 6790</i>	<i>3HAC043446-005</i>
<i>Circuit diagram - IRB 7600</i>	<i>3HAC13347-1 3HAC025744-001</i>
<i>Circuit diagram - IRB 14000</i>	<i>3HAC050778-003</i>
<i>Circuit diagram - IRB 910SC</i>	<i>3HAC056159-002</i>

Index

A

Absolute Accuracy, calibration, 770
 additional mechanical stop location, 139
 allergenic material, 30
 aluminum
 disposal, 799
 ambient humidity
 operation, 45
 storage, 45
 ambient temperature
 operation, 45
 storage, 45
 assembly instructions, 41
 assessment of hazards and risks, 30
 axis-6
 gearbox
 replacing, 755
 axis-1 gearbox
 replacing, 680
 axis 1
 gearbox
 replacing, 564
 mechanical stop
 replacing, 479
 motor
 replacing, 483
 axis 2
 gearbox
 replacing, 642
 motor
 replacing, 497
 axis 3
 gearbox
 replacing, 718
 motor
 replacing, 510
 axis 4
 motor
 replacing, 522
 axis 5
 motor
 replacing, 533
 axis 6
 motor
 replacing, 550
 Axis Calibration, 781
 calibration tool
 article number, 784, 787
 examining, 784
 installation position, 786
 overview of method, 781
 procedure on FlexPendant, 787, 794
 protective cover and protection plug, 786–787

B

balancing device
 inspection, 127
 lubrication of front eye bearing, 180
 replacing, 448
 base plate
 guide pins, 64
 securing, 64
 batteries
 disposal, 799

battery
 replacing, 177
 battery shutdown
 service routine, 177
 bearing
 balancing device front eye, 180
 brake release, 78
 brake release unit
 replacing, 279
 brakes
 testing function, 38
 BRU
 replacing, 279
 buttons for brake release, 78

C

cabinet lock, 31
 cable harness
 replacing, 219, 243
 cable harness attachments, 131
 cabling, robot, 90
 cabling between robot and controller, 90
 calibrating
 robot, 781
 roughly, 775, 779
 calibrating robot, 781, 793–794
 calibration
 Absolute Accuracy type, 768
 rough, 775, 779
 standard type, 768
 verification, 796
 when to calibrate, 771
 calibration, Absolute Accuracy, 770
 calibration manuals, 770
 calibration marks, 772
 Calibration Pendulum
 overview of method, 793
 calibration position
 jogging to, 797–798
 scales, 772
 calibration scales, 772
 CalibWare, 768
 carbon dioxide extinguisher, 31
 cast iron
 disposal, 799
 changing oil
 axis 1, 147
 axis 2, 154
 axis 3, 159
 axis 4, 165
 axis 5, 169
 axis 6, 173
 cleaning, 182
 climbing on robot, 34
 Cold environments, 101
 connecting the robot and controller, cabling, 90
 cooling fan, 95
 copper
 disposal, 799

D

damage to additional mechanical stop, 139
 damage to mechanical stop, 137
 dampers
 inspection, 141
 direction of axes, 774

E

environmental information, 799
EPS, 86
equipment, on robot, 81
ESD
 damage elimination, 55
 sensitive equipment, 55
expected life, 107
extended working range, 86
extended working range, axis 1, 86

F

fan, 95
fire extinguishing, 31
fitting equipment to robot, 81
FlexPendant
 jogging to calibration position, 797–798
 MoveAbsJ instruction, 797–798
 updating revolution counters, 776, 779
foundation
 requirements, 44
 securing robot, 75

G

gearbox
 axis-6
 replacing, 755
 axis 1
 replacing, 564
 axis 2
 replacing, 642
 axis 3
 replacing, 718
 inspecting oil level axis 1, 110
 inspecting oil level axis 2, 115
 inspecting oil level axis 3, 117
 inspecting oil level axis 4, 120
 inspecting oil level axis 5, 122
 inspecting oil level axis 6, 124
 oil change axis 1, 147
 oil change axis 2, 154
 oil change axis 3, 159
 oil change axis 4, 165
 oil change axis 5, 169
 oil change axis 6, 173
gearbox axis-1
 replacing, 603
gearboxes
 location of, 145
grease, 34
 disposal, 799
guide pins, base plate, 64

H

hanging
 installed hanging, 30
hazard levels, 21
hazardous material, 799
height
 installed at a height, 30
holes for equipment, 81
hot surfaces, 34
HRA, 30
humidity
 operation, 45
 storage, 45

I

information labels location, 133
inspecting
 additional mechanical stop, 139
 cable harness, 131
 dampers, 141
 information labels, 133
 mechanical stop, 137
 motor seal, 108
inspecting balancing device, 127
inspecting oil levels
 axis 1, 110
 axis 2, 115
 axis 3, 117
 axis 4, 120
 axis 5, 122
 axis 6, 124
installation
 mechanical stop axis 1, 88
installation on track motion carriage, 76
installation procedure, 62
installing
 motor cooling fan, 95
instructions for assembly, 41
integrator responsibility, 30
intervals for maintenance, 105

L

labels
 robot, 23
leak-down test, 186
lifting
 complete arm system, 194
 lower and upper arm together, 205, 211
 robot, 66, 69
 upper arm, 216
lifting accessory, 813
lifting accessory, robot, 67
lifting robot
 with lifting accessory, 67
limitation of liability, 19
Lithium
 disposal, 799
loads on foundation, 43
lock and tag, 31
lower arm
 replacing, 364
lubricants, 34
lubricating
 spherical roller bearing, 180
lubrication
 amount in gearboxes, 145
 type of lubrication, 145

M

magnesium
 disposal, 799
maintenance intervals, 105
maintenance schedule, 105
manually releasing brakes, 78
mechanical stop
 axis 1, 88
 replacing, 479
mechanical stop location, 137
motor
 axis 1
 replacing, 483

- axis 2
 - replacing, 497
- axis 3
 - replacing, 510
- axis 4
 - replacing, 522
- axis 5
 - replacing, 533
- axis 6
 - replacing, 550
- motor cooling fan, 95
- motor seal
 - inspecting, 108
- MoveAbsJ instruction, 797–798

N

- national regulations, 30
- negative directions, axes, 774
- neodymium
 - disposal, 799
- nodular iron
 - disposal, 799

O

- oil, 34
 - amount in gearboxes, 145
 - disposal, 799
 - type of oil, 145
- oil change
 - axis 1, 147
 - axis 2, 154
 - axis 3, 159
 - axis 4, 165
 - axis 5, 169
 - axis 6, 173
- oil level
 - gearbox axis 1, 110
 - gearbox axis 2, 115
 - gearbox axis 3, 117
 - gearbox axis 4, 120
 - gearbox axis 5, 122
 - gearbox axis 6, 124
- operating conditions, 45
- option
 - Extended working range, 86
- original spare parts, 19

P

- pedestal
 - installed on pedestal, 30
- personnel
 - requirements, 20
- plastic
 - disposal, 799
- positive directions, axes, 774
- PPE, 20
- product standards, 808
- protection classes, 45
- protection type, 45
- protective equipment, 20
- protective wear, 20

R

- rear bearings
 - replacing, 467
- recycling, 799
- regional regulations, 30

- release brakes, 37
- replacements, report, 185
- replacing
 - axis-6 gearbox, 755
 - axis-6 motor, 550
 - axis-5 motor, 533
 - axis-4 motor, 522
 - axis-3 gearbox, 718
 - axis-3 motor, 510
 - axis-2 gearbox, 642
 - axis-2 motor, 497
 - axis-1 gearbox, 564, 680
 - axis-1 motor, 483
 - balancing device, 448
 - battery, 177
 - brake release unit, 279
 - cable harness, 219, 243
 - gearbox axis-1, 603
 - lower arm, 364
 - mechanical stop pin, 479
 - SMB unit, 273
 - turning disc, 352
 - upper arm, 284
 - wrist, 327
 - xx, 467
- report replacements, 185
- requirements on foundation, 44
- responsibility and validity, 19
- restricting
 - working range axis 1, 86, 88
- revolution counters
 - storing on FlexPendant, 776, 779
 - updating, 775, 779
- risk of burns, 34
- risk of tipping, 52
- robot
 - labels, 23
 - lifting, 66, 69
 - protection class, 45
 - protection types, 45
 - securing to foundation, 75
 - securing to track motion, 76
 - symbols, 23
- roundslings
 - lifting the robot, 69
- rubber
 - disposal, 799

S

- safety
 - brake testing, 38
 - ESD, 55
 - fire extinguishing, 31
 - release robot axes, 37
 - signal lamp, 94
 - signals, 21
 - signals in manual, 21
 - symbols, 21
 - symbols on robot, 23
- safety devices, 31
- safety equipment
 - mechanical stop, 88
 - signal lamp, 143
- safety hazard
 - hydraulic system, 32
 - pneumatic system, 32
- safety signals

- in manual, 21
- safety standards, 808
- scales on robot, 772
- schedule of maintenance, 105
- screw joints, 810
- securing
 - base plate, 64
- securing the robot to foundation, attachment screws, 74
- serial measurement board
 - replacing, 273
- signal lamp, 94
- signals
 - safety, 21
- SMB
 - replacing, 273
- SMB battery
 - extension of lifetime, 177
 - replacing, 177
- speed
 - adjusting, 101
- stability, 52
- standards, 808
 - ANSI, 808
 - CAN, 808
- start of robot in cold environments, 101
- steel
 - disposal, 799
- stop pin
 - replacing, 479
- storage conditions, 45
- symbols
 - safety, 21
- synchronization position, 775, 779
- sync marks, 772
- system integrator requirements, 30

T

- temperatures
 - operation, 45
 - storage, 45
- testing
 - brakes, 38
- torques on foundation, 43
- track motion

- securing robot, 76
- transporting the robot, 60
- transport support, 60
- troubleshooting
 - oil spills, 182
 - safety, 39
- turning disc
 - replacing, 352
- type A motors, 805
- type B motors, 805

U

- upcycling, 799
- updating revolution counters, 775, 779
- upper arm
 - replacing, 284
- users
 - requirements, 20

V

- validity and responsibility, 19
- velocity
 - adjusting, 101
- verifying calibration, 796

W

- weight, 43
 - axis-1 gearbox, 581, 584, 621, 623
 - axis-1 gearbox and base, 619, 628
 - axis-1 motor, 488, 491, 575, 594, 613, 633
 - balancing device, 370, 436, 452, 457, 471, 649, 686
 - base plate, 63, 65
 - robot, 68, 72, 580, 589, 618, 630
 - upper arm, complete, 217, 301, 307, 309–310, 387, 401, 403–404, 730, 743–745
- working range
 - restricting axis 1, 88
- wrist
 - replacing, 327
- Wrist Optimization
 - overview of method, 794

Z

- zero position
 - checking, 797