

ROBOTICS

Product specification

IRB 6700



Trace back information:
Workspace 22A version a16
Checked in 2022-03-11
Skribenta version 5.4.005

Product specification

IRB 6700-300/2.70
IRB 6700-270/2.70 LID
IRB 6700-245/3.00
IRB 6700-220/3.00 LID
IRB 6700-235/2.65
IRB 6700-220/2.65 LID
IRB 6700-205/2.80
IRB 6700-200/2.80 LID
IRB 6700-200/2.60
IRB 6700-175/2.60 LID
IRB 6700-175/3.05
IRB 6700-155/3.05 LID
IRB 6700-155/2.85
IRB 6700-140/2.85 LID
IRB 6700-150/3.20
IRB 6700-145/3.20 LID
IRB 6700I-300/2.60
IRB 6700I-270/2.60 LID
IRB 6700I-245/2.90
IRB 6700I-210/2.90 LID

OmniCore

Document ID: 3HAC080365-001

Revision: B

The information in this manual is subject to change without notice and should not be construed as a commitment by ABB. ABB assumes no responsibility for any errors that may appear in this manual.

Except as may be expressly stated anywhere in this manual, nothing herein shall be construed as any kind of guarantee or warranty by ABB for losses, damage to persons or property, fitness for a specific purpose or the like.

In no event shall ABB be liable for incidental or consequential damages arising from use of this manual and products described herein.

This manual and parts thereof must not be reproduced or copied without ABB's written permission.

Keep for future reference.

Additional copies of this manual may be obtained from ABB.

Original instructions.

© Copyright 20212022 ABB. All rights reserved.
Specifications subject to change without notice.

Table of contents

Overview of this product specification	7
1 Description	9
1.1 Structure	9
1.1.1 Introduction	9
1.1.2 Different robot versions	12
1.1.3 Definition of version designations	13
1.2 Standards	18
1.2.1 Applicable standards	18
1.3 Installation	19
1.3.1 Introduction to installation	19
1.3.2 Operating requirements	20
1.3.3 Assembling the manipulator	21
1.4 Calibration and references	24
1.4.1 Calibration methods	24
1.4.2 Fine calibration	26
1.4.3 Absolute Accuracy calibration	27
1.5 Load diagrams	30
1.5.1 Introduction	30
1.5.2 Diagrams	31
1.5.3 Maximum load and moment of inertia for full and limited axis 5 (center line down) movement	61
1.5.4 Wrist torque	65
1.5.5 Maximum TCP acceleration	66
1.6 Fitting equipment to the robot	67
1.7 Maintenance and troubleshooting	76
1.8 Robot motion	77
1.8.1 Robot motion	77
1.8.2 Performance according to ISO 9283	90
1.8.3 Velocity	92
1.8.4 Robot stopping distances and times	93
2 DressPack	95
2.1 Introduction	95
2.1.1 Included options	95
2.1.2 Product range	96
2.1.3 Limitations of robot movements	97
2.1.4 Impact on MH3 DressPack lifetime	98
2.1.5 Information structure	99
2.2 DressPack	100
2.2.1 Introduction	100
2.2.2 Built-in features for upper arm DressPack	101
2.2.3 Interface descriptions for DressPack	102
2.2.4 Dimensions	107
2.3 Connection kits	109
2.3.1 Base - Connector kits	110
2.3.2 Axis 3 - Connector kits	111
2.3.3 Axis 6 - Connector kits	112
3 Specification of variants and options	113
3.1 Introduction to variants and options	113
3.2 Manipulator	114
3.3 Floor cables	119
3.4 Application	120
Index	123

This page is intentionally left blank

Overview of this product specification

About this product specification

This product specification describes the performance of the manipulator or a complete family of manipulators in terms of:

- The structure and dimensional prints
- The fulfilment of standards, safety, and operating equipment
- The load diagrams, mounting or extra equipment, the motion, and the robot reach
- The specification of available variants and options

The specification covers the manipulator using the OmniCore controller.

Usage

Product specifications are used to find data and performance about the product, for example to decide which product to buy. How to handle the product is described in the product manual.

The specification is intended for:

- Product managers and product personnel
- Sales and marketing personnel
- Order and customer service personnel

References

Reference	Document ID
<i>Product specification - OmniCore V line</i>	3HAC074671-001
<i>Product manual - IRB 6700</i>	3HAC044266-001
<i>Product manual - IRB 6700Inv</i>	3HAC058254-001
<i>Product manual - OmniCore V250XT</i>	3HAC073447-001

Revisions

Revision	Description
A	First edition.
B	Published in release 22A. The following updates are done in this revision: <ul style="list-style-type: none"> • Updated the DressPack section, especially in connector kits chapter.

This page is intentionally left blank

1 Description

1.1 Structure

1.1.1 Introduction

General

The IRB 6700 series is ABB Robotics 7th generation of high payload, high performance industrial robots. Based on the famous IRB 6640 series, with large working range, the very high wrist torque, the service friendly modular built up and the availability, significant for ABB's robots, the IRB 6700 robot family goes even further. With focus on high production capacity, compact design and low weight, simple service and low maintenance cost. The IRB 6700 is ideal for process applications, regardless of industry.

Typical areas are for example Material Handling, Machine Tending.

Software product range

We have added a range of software products - all falling under the umbrella designation of Active Safety - to protect not only personnel in the unlikely event of an accident, but also robot tools, peripheral equipment and the robot itself.

Options

There are a large number of options for material handling and spot welding integrated in the robot. For a complete description of Material handling see [DressPack on page 95](#).

Operating system

The robot is equipped with the OmniCore V250XT controller and robot control software, RobotWare. RobotWare supports every aspect of the robot system, such as motion control, development and execution of application programs, communication etc. See *Product specification - OmniCore V line*.

Safety

Safety standards valid for complete robot, manipulator and controller.

Additional functionality

For additional functionality, the robot can be equipped with optional software for application support - for example gluing and welding, communication features - network communication - and advanced functions such as multitasking, sensor control etc. For a complete description on optional software, see the *Product specification - OmniCore V line*.

Protection type Foundry Plus 2

Robots with the option Foundry Plus 2 are designed for harsh environments where the robot is exposed to sprays of coolants, lubricants and metal spits that are typical for die casting applications or other similar applications.

Continues on next page

1 Description

1.1.1 Introduction

Continued

Typical applications are spraying insertion and part extraction of die-casting machines, handling in sand casting and gravity casting, etc. (Please refer to Foundry Prime robots for washing applications or other similar applications). Special care must be taken in regard to operational and maintenance requirements for applications in foundry as well as in other applications areas. Please contact ABB Robotics Sales organization if in doubt regarding specific application feasibility for the Foundry Plus 2 protected robot.

The robot is painted with two-component epoxy on top of a primer for corrosion protection. To further improve the corrosion protection additional rust preventive are applied to exposed and crucial areas, e.g. has the tool flange a special preventive coating. Although, continuous splashing of water or other similar rust formation fluids may cause rust attach on the robots unpainted areas, joints, or other unprotected surfaces. Under these circumstances it is recommended to add rust inhibitor to the fluid or take other measures to prevent potential rust formation on the mentioned.

The entire robot is IP67 compliant according to IEC 60529 - from base to wrist, which means that the electrical compartments are sealed against water and solid contaminants. Among other things all sensitive parts are better protected than the standard offer.

Selected Foundry Plus 2 features:

- Improved sealing to prevent penetration into cavities to secure IP67
- Additional protection of cabling and electronics
- Special covers that protect cavities
- Well-proven connectors
- Nickel coated tool flange
- Rust preventives on screws, washers and unpainted/machined surfaces
- Extended service and maintenance program

The Foundry Plus 2 robot can be cleaned with appropriate washing equipment according to the robot product manual. Appropriate cleaning and maintenance is required to maintain the protection, for example can rust preventive be washed off with wrong cleaning method.

Available robot versions

The option Foundry Plus 2 might not be available for all robot versions.

See [Specification of variants and options on page 113](#) for robot versions and other options not selectable together with Foundry Plus 2.

Continues on next page

Robot axes

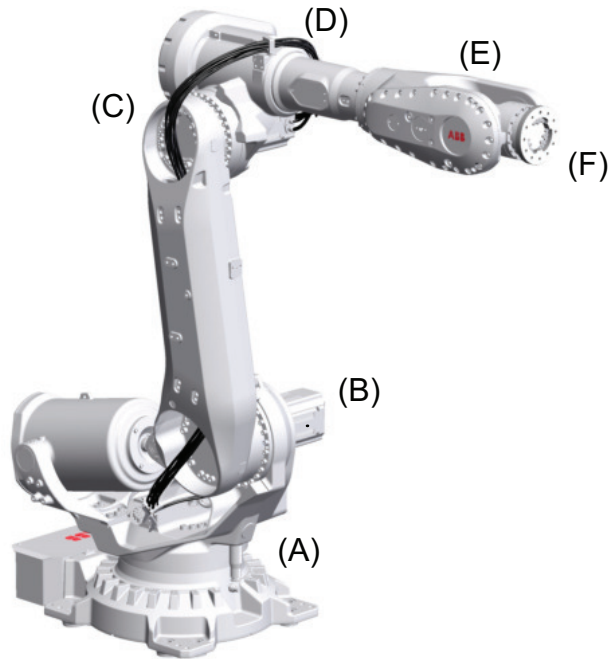

xx130000244

Pos	Description	Pos	Description
A	Axis 1	B	Axis 2
C	Axis 3	D	Axis 4
E	Axis 5	F	Axis 6

1 Description

1.1.2 Different robot versions

1.1.2 Different robot versions

General

The IRB 6700 is available in twenty versions.

Robot versions

The following standard robot versions are available.

Robot variants	Handling capacity (kg)	Reach (m)
6700-300/2.70	300	2.70
6700-270/2.70 LID	270	2.70
6700-245/3.00	245	3.00
6700-220/3.00 LID	220	3.00
6700-235/2.65	235	2.65
6700-220/2.65 LID	220	2.65
6700-205/2.80	205	2.80
6700-200/2.80 LID	200	2.80
6700-200/2.60	200	2.60
6700-175/2.60 LID	175	2.60
6700-175/3.05	175	3.05
6700-155/3.05 LID	155	3.05
6700-155/2.85	155	2.85
6700-140/2.85 LID	140	2.85
6700-150/3.20	150	3.20
6700-145/3.20 LID	145	3.20
6700I-300/2.60	300	2.60
6700I-270/2.60 LID	270	2.60
6700I-245/2.90	245	2.90
6700I-210/2.90 LID	210	2.90



Note

If LeanID is selected, the payload will decrease as stated above, for detailed information see [Load diagrams on page 30](#)

1.1.3 Definition of version designations

Manipulator weight

Robot type	Weight [kg] ⁱ
IRB 6700 - 300/2.70	1,525
IRB 6700 - 270/2.70 LID	1,525
IRB 6700 - 245/3.00	1,540
IRB 6700 - 220/3.00 LID	1,540
IRB 6700 - 235/2.65	1,250
IRB 6700 - 220/2.65 LID	1,250
IRB 6700 - 205/2.80	1,260
IRB 6700 - 200/2.80 LID	1,260
IRB 6700 - 200/2.60	1,205
IRB 6700 - 175/2.60 LID	1,205
IRB 6700 - 175/3.05	1,270
IRB 6700 - 155/3.05 LID	1,270
IRB 6700 - 155/2.85	1,220
IRB 6700 - 140/2.85 LID	1,220
IRB 6700 - 150/3.20	1,280
IRB 6700 - 145/3.20 LID	1,280
IRB 6700I - 300/2.60	1,690
IRB 6700I - 270/2.60 LID	1,690
IRB 6700I - 245/2.90	1,705
IRB 6700I - 210/2.90 LID	1,705

ⁱ Weight without DressPack

Other technical data

Data	Description	Note
Airborne noise level	The sound pressure level outside the working space.	< 71 dB (A) Leq (acc. to machinery directive 2006/42/EG)

Continues on next page

1 Description

1.1.3 Definition of version designations

Continued

Power consumption at max speed (vmax)

	235/2.65 205/2.80 200/2.60 175/3.05 155/2.85 150/3.20	300/2.70 245/3.00	I-300/2.60 I-300/2.60
ISO Cube Max. velocity (kW)	2.8	3.4	3.4
Robot in calibration position	235/2.65 205/2.80 200/2.60 175/3.05 155/2.85 150/3.20	300/2.70 245/3.00	I-300/2.60 I-300/2.60
Brakes engaged (kW)	0.24	0.24	0.24
Brakes disengaged (kW)	0.87	0.87	1.07

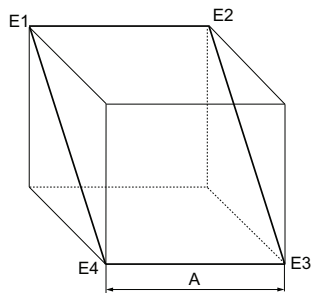

xx1000000101

A	1,000 mm
---	----------

Power factor (cos φ)

The power factor is above 0.95 at a steady state power consumption higher than 2.0 kW, when the IRB 6700 is connected to the OmniCore V line.

Continues on next page

Main dimensions of IRB 6700

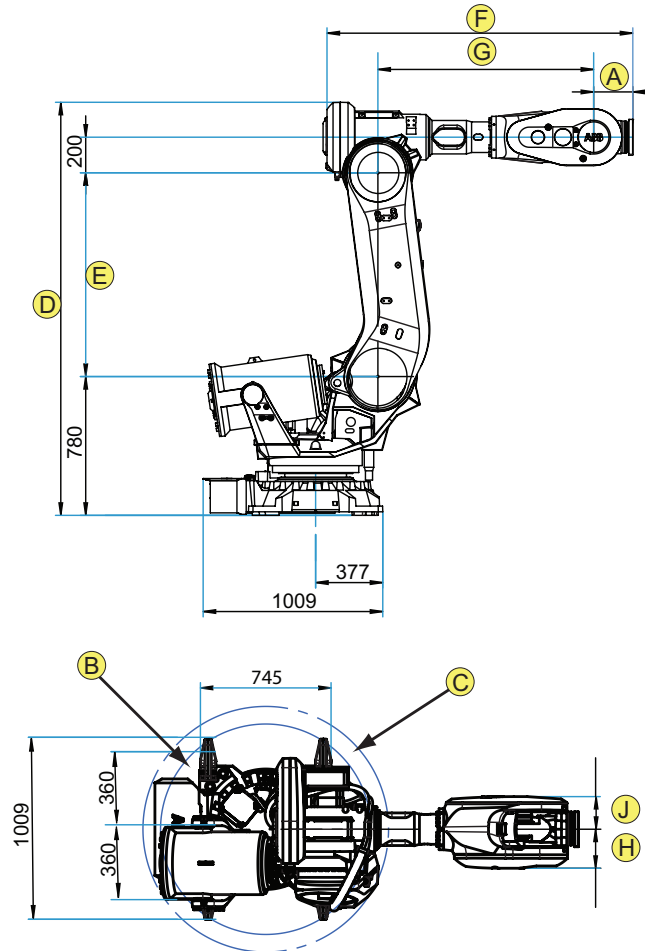

xx130000241

Pos	Description
A	200 mm (all standard variants); except 300/2.70 and 245/3.00 =220 mm 350 mm (all LeanID variants); except IRB 6700-270/2.70 LID and IRB 6700-220/3.00 LID = 380 mm
B	Radius ax1, front = 532 mm (IRB 6700-235/2.65, -220/2.65 LID, -205/2.80, -200/2.80 LID, -175/3.05, -155/3.05 LID, -150/3.20, -145/3.20 LID, -200/2.60, -175/2.60 LID, -155/2.85 and 140/2.85 LID) Radius ax1, front = 600 mm (IRB 6700-300/2.70, -270/2.70 LID, -245/3.00 and -220/3.00 LID)
C	Radius ax1, back = 700 mm (IRB 6700-300/2.70, 6700-270/2.70 LID, -245/3.00 and -220/3.00 LID)

Robot variant	D	E	F	G	H	J
IRB 6700 - 235/2.65	2300	1135	1670	1182.5	209	186
IRB 6700 - 205/2.80	2445	1280	1670	1182.5	186	209
IRB 6700 - 200/2.60	2276	1125	1623	1,142.5	197.5	193
IRB 6700 - 175/3.05	2300	1135	2080	1,592.5	209	186
IRB 6700 - 150/3.20	2445	1280	2080	1592.5	209	186

Continues on next page

1 Description

1.1.3 Definition of version designations

Continued

Robot variant	D	E	F	G	H	J
IRB 6700 - 155/2.85	2276	1125	1873	1,392.5	197.5	193
IRB 6700 - 300/2.70	2321	1145	1718.5	1212.5	222.5	187
IRB 6700 - 245/3.00	2321	1145	1968.5	1462.5	222.5	186
IRB 6700 - 220/2.65 LID	2300	1135	1820	1182.5	209	186
IRB 6700 - 200/2.80 LID	2445	1280	1820	1182.5	186	209
IRB 6700 - 155/3.05 LID	2300	1135	2230	1592.5	209	186
IRB 6700 - 145/3.20 LID	2445	1280	2230	1592.5	209	186
IRB 6700 - 175/2.60 LID	2276	1125	1773	1142.5	197.5	193
IRB 6700 - 140/2.85 LID	2276	1125	2023	1392.5	197.5	193
IRB 6700 - 270/2.70 LID	2321	1145	1878.5	1212.5	222.5	187
IRB 6700 - 220/3.00 LID	2321	1145	2128.5	1462.5	222.5	186



Note

For DressPack dimensions, see [Dimensions for robot with DressPack on page 107](#)

Continues on next page

Main dimensions of IRB 6700 inverted variants

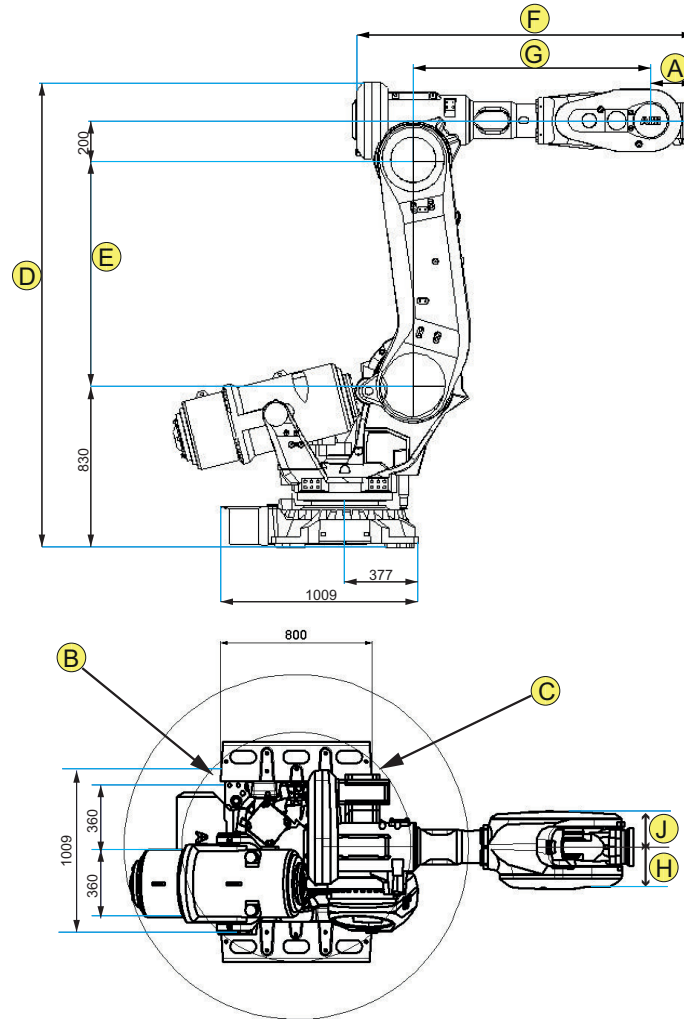

xx170000559

Pos	Description
A	220 mm (all IRB 6700Inv variants) 380 mm (all IRB 6700Inv LeanID variants)
B	Radius ax1, front = 626 mm
C	Radius ax1, back = 910 mm

Robot variant	D	E	F	G	H	J
IRB 6700I-300/2.60	2372	1145	1718.5	1212.5	222.5	187
IRB 6700I-245/2.90	2372	1145	1968.5	1468.5	222.5	186
IRB 6700I - 210/2.90 LID	2372	1145	2128.5	1468.5	222.5	186
IRB 6700I - 270/2.60 LID	2372	1145	1878.5	1212.5	222.5	187

1 Description

1.2.1 Applicable standards

1.2 Standards

1.2.1 Applicable standards

General

The product is compliant with ISO 10218-1:2011, *Robots for industrial environments - Safety requirements - Part 1 Robots*, and applicable parts in the normative references, as referred to from ISO 10218-1:2011. In case of deviation from ISO 10218-1:2011, these are listed in the declaration of incorporation. The declaration of incorporation is part of the delivery.

Robot standards

Standard	Description
ISO 9283	Manipulating industrial robots – Performance criteria and related test methods
ISO 9787	Robots and robotic devices – Coordinate systems and motion nomenclatures
ISO 9946	Manipulating industrial robots – Presentation of characteristics

Other standards used in design

Standard	Description
IEC 60204	Safety of machinery - Electrical equipment of machines - Part 1: General requirements, normative reference from ISO 10218-1
IEC 61000-6-2	Electromagnetic compatibility (EMC) – Part 6-2: Generic standards – Immunity standard for industrial environments
IEC 61000-6-4	Electromagnetic compatibility (EMC) – Part 6-4: Generic standards – Emission standard for industrial environments
ISO 13849-1:2006	Safety of machinery - Safety related parts of control systems - Part 1: General principles for design, normative reference from ISO 10218-1

Region specific standards and regulations

Standard	Description
ANSI/RIA R15.06	Safety requirements for industrial robots and robot systems
ANSI/UL 1740	Safety standard for robots and robotic equipment
CAN/CSA Z 434-03	Industrial robots and robot Systems - General safety requirements
EN ISO 10218-1	Robots and robotic devices — Safety requirements for industrial robots — Part 1: Robots

1.3 Installation

1.3.1 Introduction to installation

General

IRB 6700 are designed for floor mounting (no tilting allowed around X-axis or Y-axis). IRB 6700Inv variants are designed for inverted mounting (no tilting allowed around X-axis or Y-axis). Depending on the robot version, an end effector with max. weight of 150 to 300 kg including payload, can be mounted on the tool flange (axis 6). See [Load diagrams on page 30](#).

Extra loads

Extra load (valve packages, transformers, DressPack) of 50 kg, which is included in the load diagrams, can be mounted on the upper arm. An extra load of 250 kg can also be mounted on the frame of axis 1.

See [Fitting equipment to the robot on page 67](#).

Working range limitation

The working range of axes 1 can be limited by mechanical stops as option. See [Working range limitation on page 117](#).

1 Description

1.3.2 Operating requirements

1.3.2 Operating requirements

Protection standards

Robot version/Protection standard	IEC 60529
All variants, manipulator	IP67

Explosive environments

The robot must not be located or operated in an explosive environment.

Ambient temperature

Description	Standard/Option	Temperature
Manipulator during operation	Standard	Minimum: +5 °C ⁱ (41 °F) Maximum: +50 °C (122 °F)
For the controller	Standard/Option	See <i>Product specification - Omni-Core V line</i>
Complete robot during transportation and storage,	Standard	Minimum: -25 °C (-13 °F) Maximum: +55 °C (+131 °F)
for short periods (not exceeding 24 hours)	Standard	+70 °C (+158 °F)

ⁱ At low environmental temperature (below 10 °C) a warm-up phase is recommended to be run with the robot. Otherwise there is a risk that the robot stops or runs with lower performance due to temperature dependent oil and grease viscosity.

Relative humidity

Description	Relative humidity
Complete robot during transportation and storage	Maximum 95% at constant temperature.
Complete robot during operation	Maximum 95% at constant temperature.

1.3.3 Assembling the manipulator

Maximum load

Maximum load in relation to the base coordinate system.

Floor mounted

Force	Endurance load (in operation)	Max. load (emergency stop)
Force xy	$\pm 7.4 \text{ kN}^i / \pm 8.7 \text{ kN}^{ii}$	$\pm 19.8 \text{ kN}^i / \pm 21.8 \text{ kN}^{ii}$
Force z	$14.6 \pm 4.5 \text{ kN}^i / 18.0 \pm 5.4 \text{ kN}^{ii}$	$14.6 \pm 15.7 \text{ kN}^i / 18.0 \pm 17.4 \text{ kN}^{ii}$
Torque xy	$\pm 21.0 \text{ kNm}^i / \pm 24.9 \text{ kNm}^{ii}$	$\pm 37.1 \text{ kNm}^i / \pm 45.3 \text{ kNm}^{ii}$
Torque z	$\pm 5.0 \text{ kNm}^i / \pm 6.5 \text{ kNm}^{ii}$	$\pm 11.4 \text{ kNm}^i / \pm 15.5 \text{ kNm}^{ii}$

ⁱ Valid for IRB 6700-235/2.65, 205/2.80, 200/2.60, 175/3.05, 155/2.85, 150/3.20, 220/2.65 LID, 200/2.80 LID, 175/2.60 LID, 155/3.05 LID, 140/2.85 LID, 145/3.20 LID.

ⁱⁱ Valid for IRB 6700-300/2.70, -245/3.00, 270/2.70 LID, 220/3.00 LID.

Inverted Mounted

Force	Endurance load (in operation)	Max. load (emergency stop)
Force xy	$\pm 8.9 \text{ kN}^i$	$\pm 23.7 \text{ kN}^i$
Force z	$-22.1 \pm 6.6 \text{ kN}^i$	$-22.1 \pm 18.1 \text{ kN}^i$
Torque xy	$\pm 22.5 \text{ kNm}^i$	$\pm 45.4 \text{ kNm}^i$
Torque z	$\pm 6.5 \text{ kNm}^i$	$\pm 15.7 \text{ kNm}^i$

ⁱ Valid for IRB 6700I-300/2.60, I-270/2.60 LID, I-245/2.90, I-210/2.90 LID.

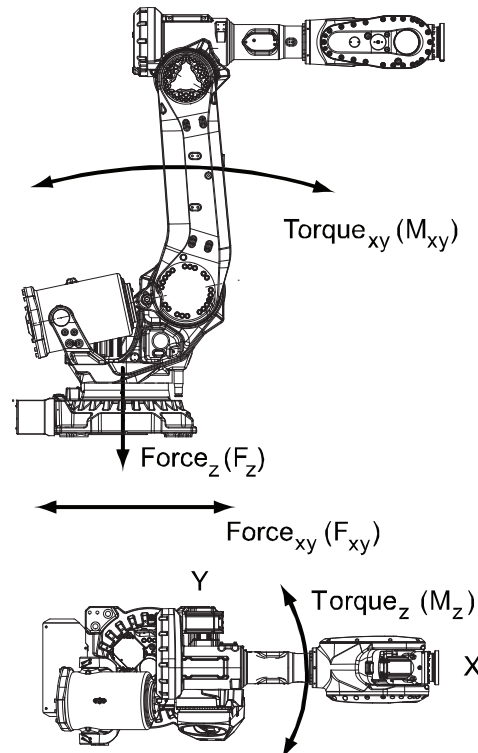

xx1300000242

Continues on next page

1 Description

1.3.3 Assembling the manipulator

Continued

Note regarding M_{xy} and F_{xy}

The bending torque (M_{xy}) can occur in any direction in the XY-plane of the base coordinate system.

The same applies to the transverse force (F_{xy}).

Fastening holes robot base - for all variants

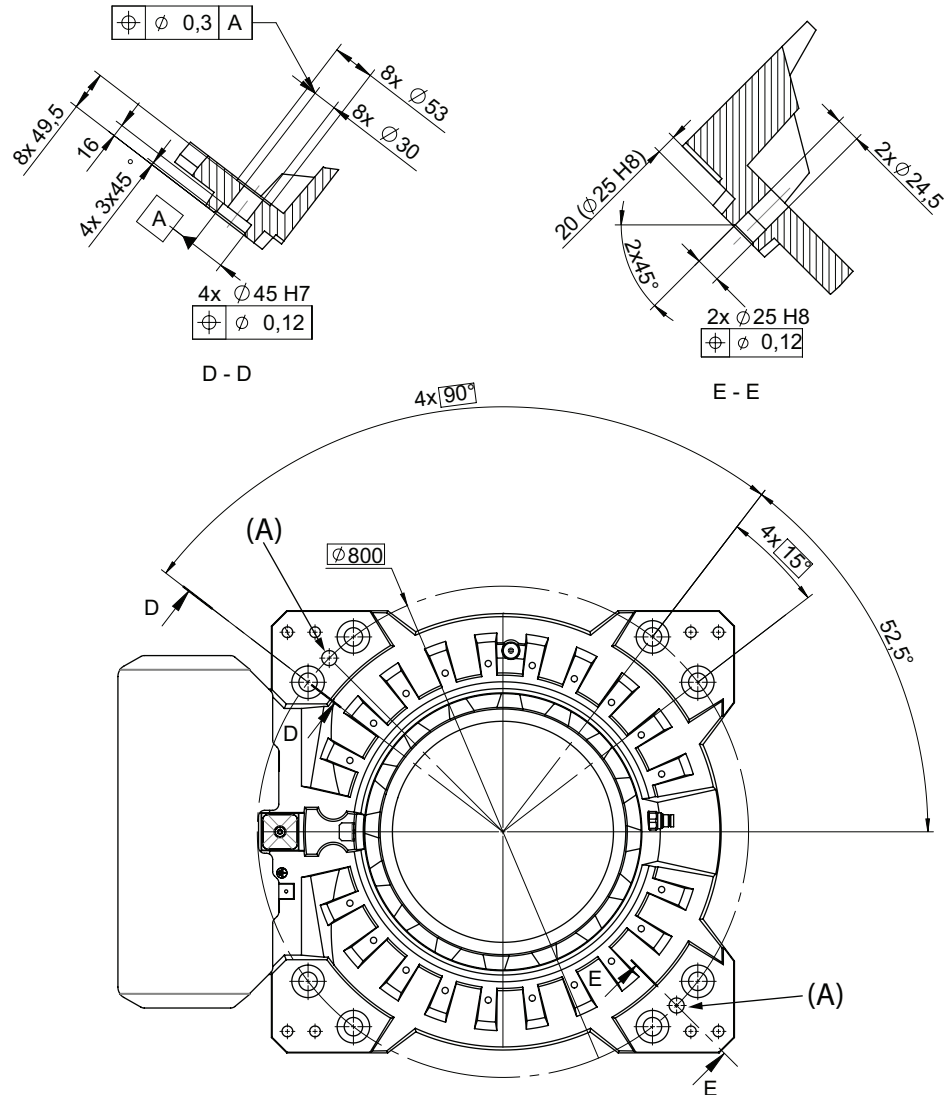

xx1300000243

Pos	Description
A	Holes for guide pins (x2)



Note

Holes for guide pins (x2) Rear hole straight slot.

Continues on next page

Fastener quality

Suitable screws:	M24 x 100 (installation on base plate/foundation)
Quality:	8.8
Screw tightening yield point utilization factor (v) (according to VDI2230):	90% (v=0.9)
Suitable washer:	4 mm flat washer
Tightening torque:	550 Nm (screws lubricated with Molykote 1000) 600-725 Nm, typical 650 Nm (screws none or lightly lubricated)



Note

Only two guide pins shall be used.

AbsAcc performance

Regarding AbsAcc performance, the use of guide pins are mandatory.

Continues on next page

1 Description

1.4.1 Calibration methods

Continued

1.4 Calibration and references

1.4.1 Calibration methods

Overview

This section specifies the different types of calibration and the calibration methods that are supplied by ABB.

The original calibration data delivered with the robot is generated when the robot is floor mounted. If the robot is not floor mounted, then the robot accuracy could be affected. The robot needs to be calibrated after it is mounted.

More information is available in the product manual.

Types of calibration

Type of calibration	Description	Calibration method
Standard calibration	The calibrated robot is positioned at calibration position. Standard calibration data is found on the SMB (serial measurement board) or EIB in the robot.	Axis Calibration
Absolute accuracy calibration (optional)	Based on standard calibration, and besides positioning the robot at synchronization position, the Absolute accuracy calibration also compensates for: <ul style="list-style-type: none">Mechanical tolerances in the robot structureDeflection due to load Absolute accuracy calibration focuses on positioning accuracy in the Cartesian coordinate system for the robot. Absolute accuracy calibration data is found on the SMB (serial measurement board) in the robot. A robot calibrated with Absolute accuracy has the option information printed on its name plate. To regain 100% Absolute accuracy performance, the robot must be recalibrated for absolute accuracy after repair or maintenance that affects the mechanical structure.	CalibWare
Optimization	Optimization of TCP reorientation performance. The purpose is to improve reorientation accuracy for continuous processes like welding and gluing. Wrist optimization will update standard calibration data for axes 4 and 5.	Wrist Optimization

Brief description of calibration methods

Axis Calibration method

Axis Calibration is a standard calibration method for calibration of IRB 6700. It is the recommended method in order to achieve proper performance.

The following routines are available for the Axis Calibration method:

- Fine calibration

Continues on next page

- Update revolution counters
- Reference calibration

The calibration equipment for Axis Calibration is delivered as a toolkit.

The actual instructions of how to perform the calibration procedure and what to do at each step is given on the FlexPendant. You will be guided through the calibration procedure, step by step.

Wrist Optimization method

Wrist Optimization is a method for improving reorientation accuracy for continuous processes like welding and gluing and is a complement to the standard calibration method.

The following routines are available for the Wrist Optimization method:

- Wrist Optimization

The actual instructions of how to perform the calibration procedure and what to do at each step is given on the FlexPendant. You will be guided through the calibration procedure, step by step.

CalibWare - Absolute Accuracy calibration

The CalibWare tool guides through the calibration process and calculates new compensation parameters. This is further detailed in the *Application manual - CalibWare Field*.

If a service operation is done to a robot with the option Absolute Accuracy, a new absolute accuracy calibration is required in order to establish full performance. For most cases after replacements that do not include taking apart the robot structure, standard calibration is sufficient.

The Absolute Accuracy option varies according to the robot mounting position. This is printed on the robot name plate for each robot. The robot must be in the correct mounting position when it is recalibrated for absolute accuracy.

1 Description

1.4.2 Fine calibration

1.4.2 Fine calibration

General

Fine calibration is made using the Axis calibration method, see *Product manual - IRB 6700* and *Product manual - IRB 6700Inv*.

Axes

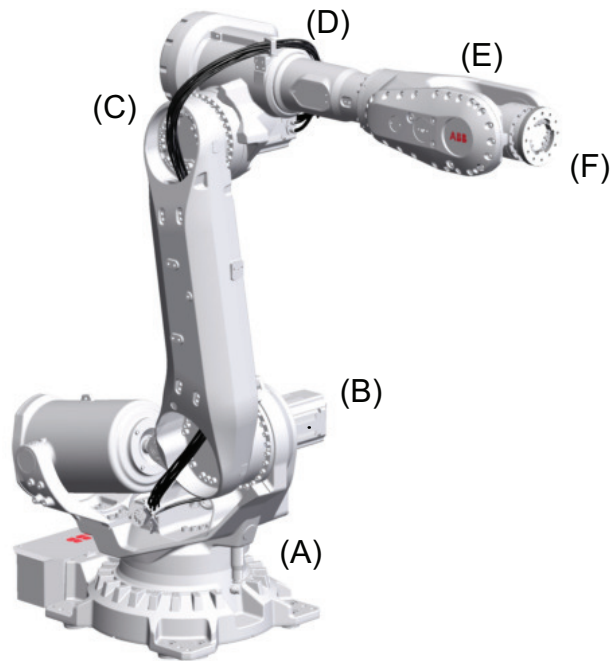

xx130000244

Pos	Description	Pos	Description
A	Axis 1	B	Axis 2
C	Axis 3	D	Axis 4
E	Axis 5	F	Axis 6

Calibration

Calibration	Position
Calibration of all axes	All axes are in zero position
Calibration of axis 1 and 2	Axis 1 and 2 in zero position
	Axis 3 to 6 in any position
Calibration of axis 1	Axis 1 in zero position
	Axis 2 to 6 in any position

1.4.3 Absolute Accuracy calibration

**Note**

IRB 6700Inv is valid for field AbsAcc but does not have an AbsAcc option.

Purpose

Absolute Accuracy is a calibration concept that improves TCP accuracy. The difference between an ideal robot and a real robot can be several millimeters, resulting from mechanical tolerances and deflection in the robot structure. *Absolute Accuracy* compensates for these differences.

Here are some examples of when this accuracy is important:

- Exchangeability of robots
- Offline programming with no or minimum touch-up
- Online programming with accurate movement and reorientation of tool
- Programming with accurate offset movement in relation to eg. vision system or offset programming
- Re-use of programs between applications

The option *Absolute Accuracy* is integrated in the controller algorithms and does not need external equipment or calculation.

**Note**

The performance data is applicable to the corresponding RobotWare version of the individual robot.

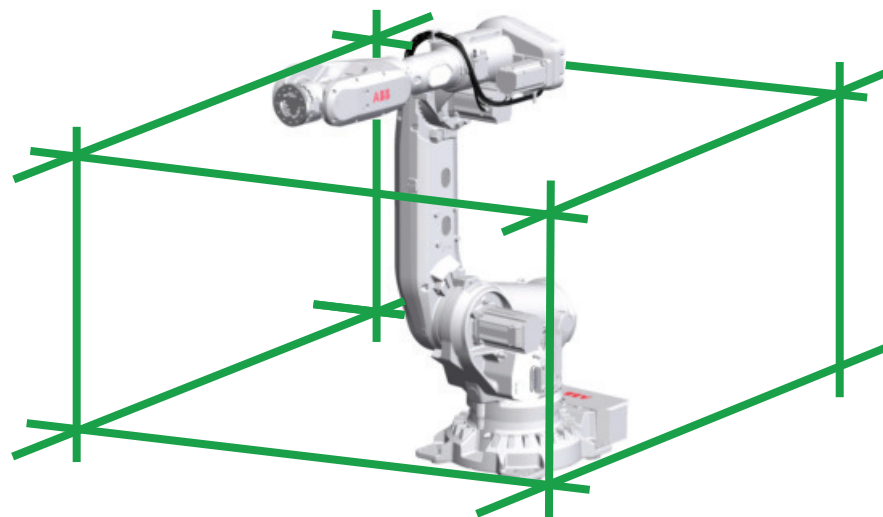

xx1300002177

What is included

Every *Absolute Accuracy* robot is delivered with:

- compensation parameters saved on the robot's serial measurement board

Continues on next page

1 Description

1.4.3 Absolute Accuracy calibration

Continued

- a birth certificate representing the *Absolute Accuracy* measurement protocol for the calibration and verification sequence.

A robot with *Absolute Accuracy* calibration has a label with this information on the manipulator.

Absolute Accuracy supports floor mounted, wall mounted and ceiling mounted installations. Compensation parameters saved in the robot's serial measurement board differ depending on which Absolute Accuracy option is selected.

When is *Absolute Accuracy* being used

Absolute Accuracy works on a robot target in Cartesian coordinates, not on the individual joints. Therefore, joint based movements (e.g. `MoveAbsJ`) will not be affected.

If the robot is inverted, the Absolute Accuracy calibration must be performed when the robot is inverted.

Absolute Accuracy active

Absolute Accuracy will be active in the following cases:

- Any motion function based on robtargets (e.g. `MoveL`) and ModPos on robtargets
- Reorientation jogging
- Linear jogging
- Tool definition (4, 5, 6 point tool definition, room fixed TCP, stationary tool)
- Work object definition

Absolute Accuracy not active

The following are examples of when Absolute Accuracy is not active:

- Any motion function based on a jointtarget (`MoveAbsJ`)
- Independent joint
- Joint based jogging
- Additional axes
- Track motion



Note

In a robot system with, for example, an additional axis or track motion, the Absolute Accuracy is active for the manipulator but not for the additional axis or track motion.

RAPID instructions

There are no RAPID instructions included in this option.

Continues on next page

Production data

Typical production data regarding calibration are:

Robot	Positioning accuracy (mm)		
	Average	Max	% Within 1 mm
IRB 6700 (all variants except LID)	0.35	0.75	100
IRB 6700 LID (all variants)	0.40	0.85	100

1 Description

1.5.1 Introduction

1.5 Load diagrams

1.5.1 Introduction



WARNING

It is very important to always define correct actual load data and correct payload of the robot. Incorrect definitions of load data can result in overloading of the robot.

If incorrect load data is used, and/or if loads outside the load diagram are used, the following parts can be damaged due to overload:

- motors
- gearboxes
- mechanical structure



WARNING

In RobotWare, the service routine LoadIdentify can be used to determine correct load parameters. The routine automatically defines the tool and the load. See *Operating manual - OmniCore*, for detailed information.



WARNING

Robots running with incorrect load data and/or with loads outside the load diagram, will not be covered by robot warranty.

General

The load diagrams include a nominal payload inertia, J_0 of 15 kgm^2 , and an extra load of 50 kg at the upper arm housing.

At different moment of inertia the load diagram will be changed. For robots that are allowed tilted, wall or inverted mounted, the load diagrams as given are valid and thus it is also possible to use RobotLoad within those tilt and axis limits.

Control of load case by "RobotLoad"

To verify a specific load case, use the RobotStudio add-in RobotLoad.

The result from RobotLoad is only valid within the maximum loads and tilt angles. There is no warning if the maximum permitted arm load is exceeded. For over-load cases and special applications, contact ABB for further analysis.

1.5.2 Diagrams

IRB 6700-235/2.65

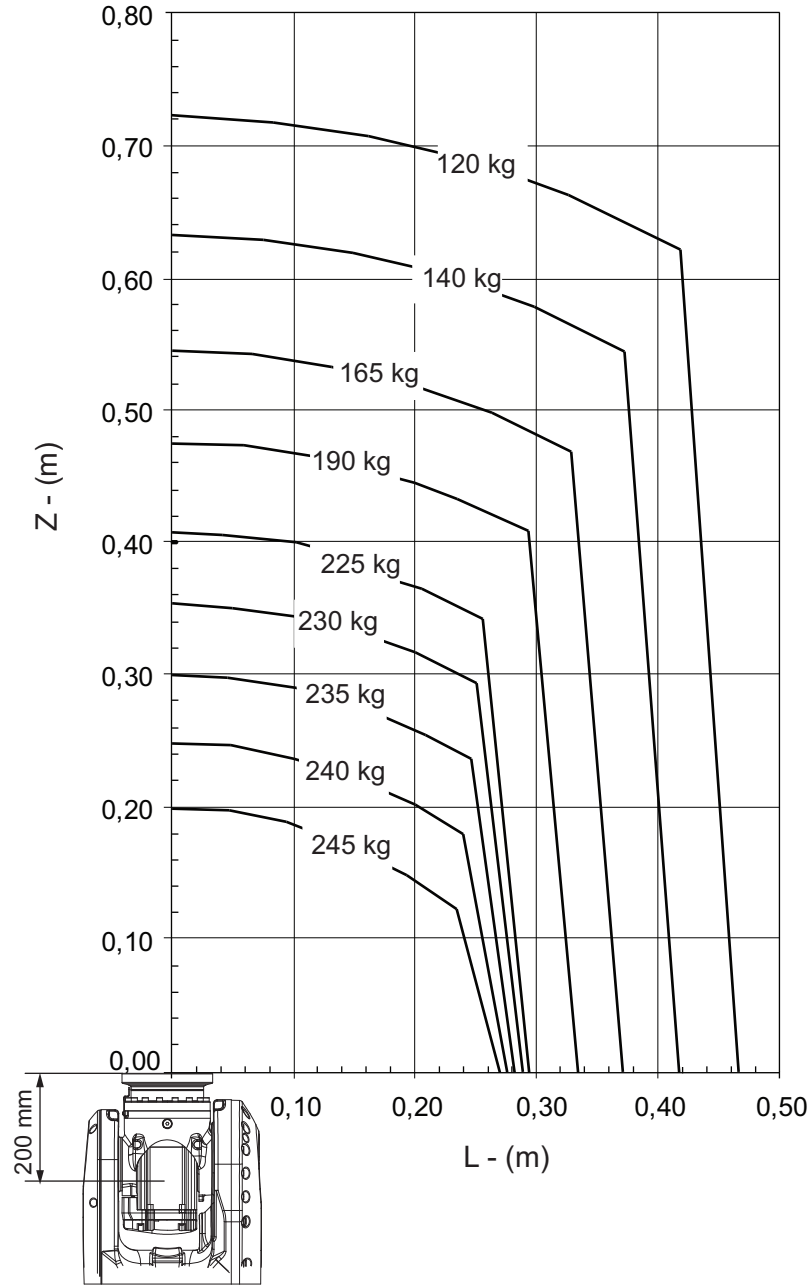

xx1300000245

Continues on next page

1 Description

1.5.2 Diagrams

Continued

IRB 6700-235/2.65 "Vertical Wrist" ($\pm 10^\circ$)

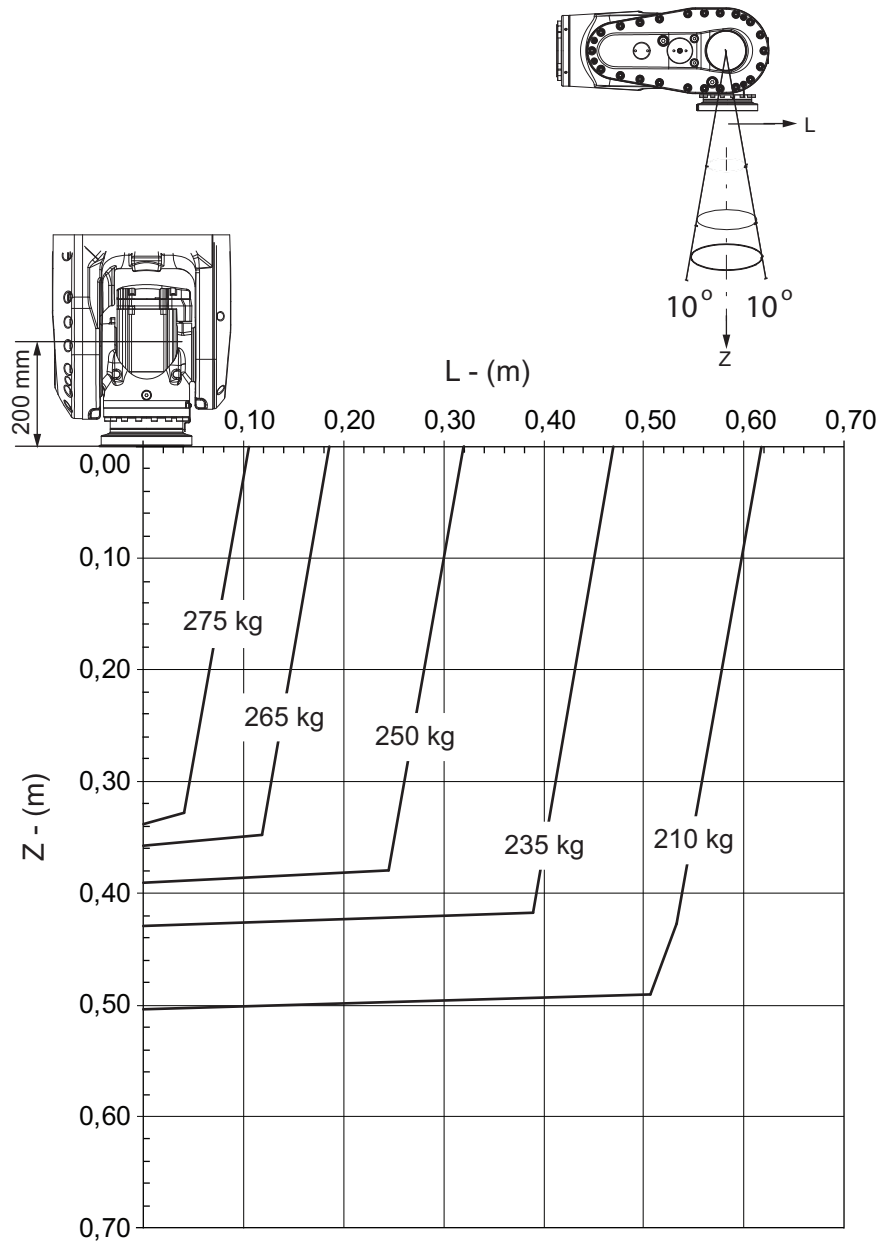

xx1300000246

For wrist down (0° deviation from the vertical line).

	Description
Max load	280 kg
Z _{max}	0.327 m
L _{max}	0.100 m

Continues on next page

IRB 6700-220/2.65 LID

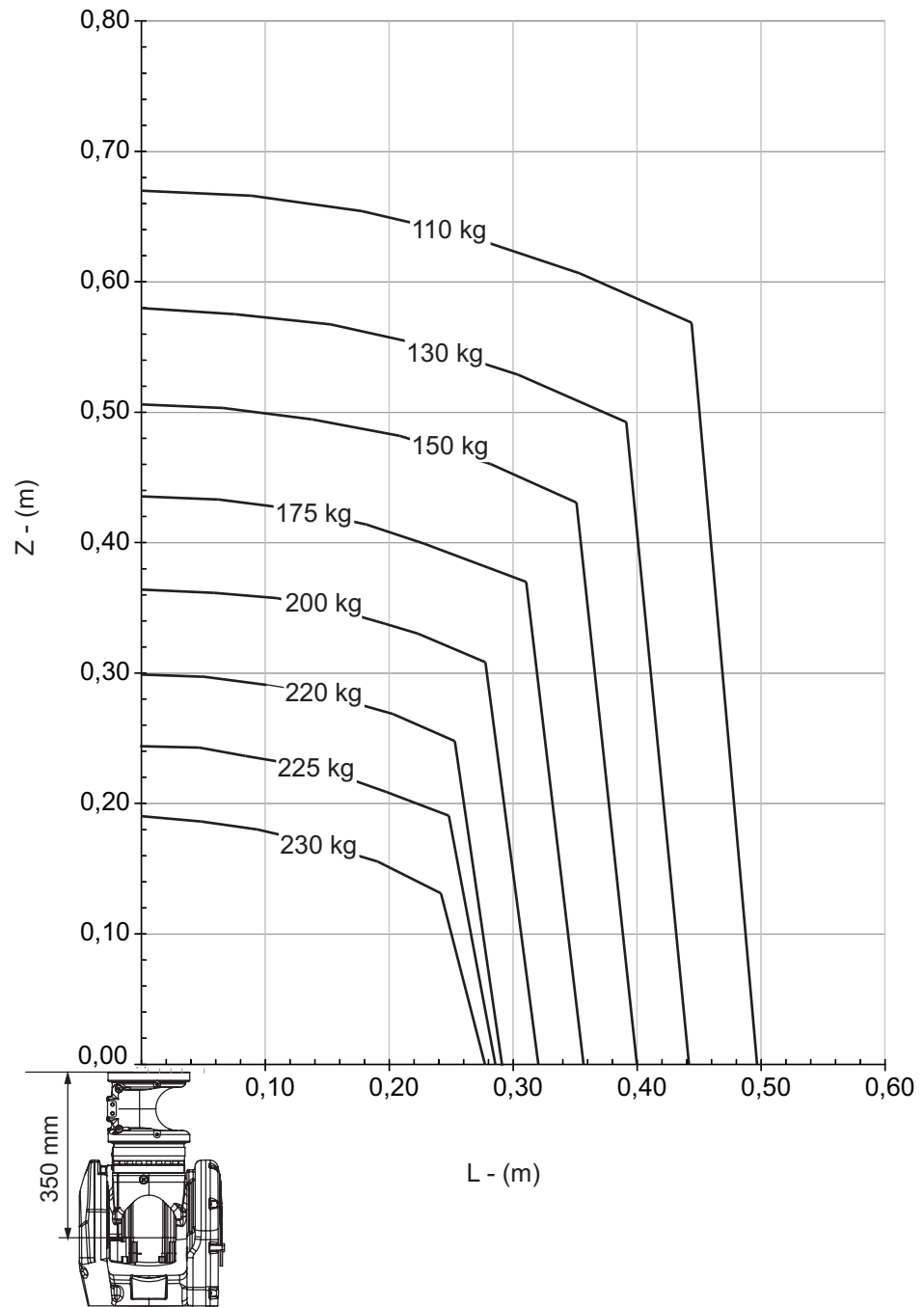

xx130000248

Continues on next page

1 Description

1.5.2 Diagrams

Continued

IRB 6700-205/2.80

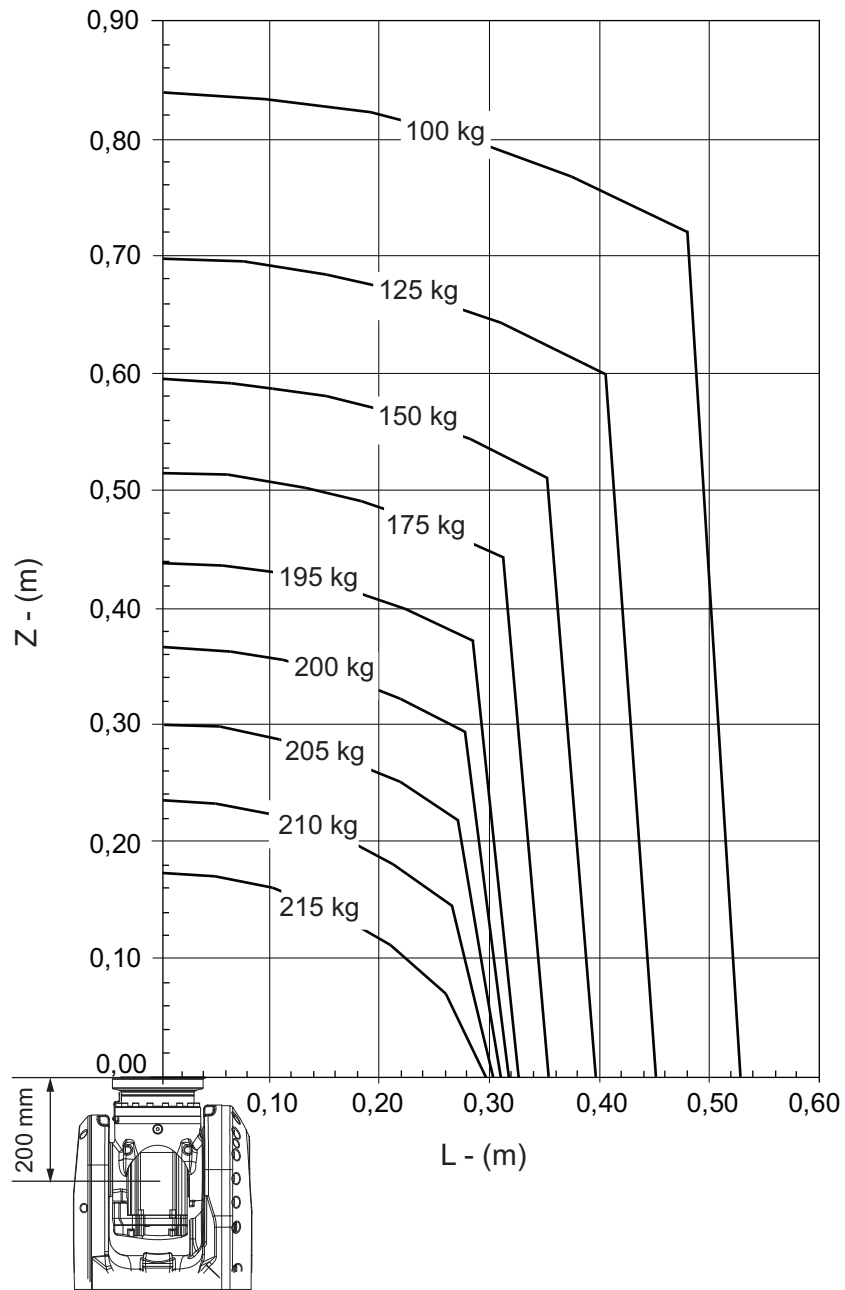

xx1300000249

Continues on next page

IRB 6700-205/2.80 "Vertical Wrist" ($\pm 10^\circ$)

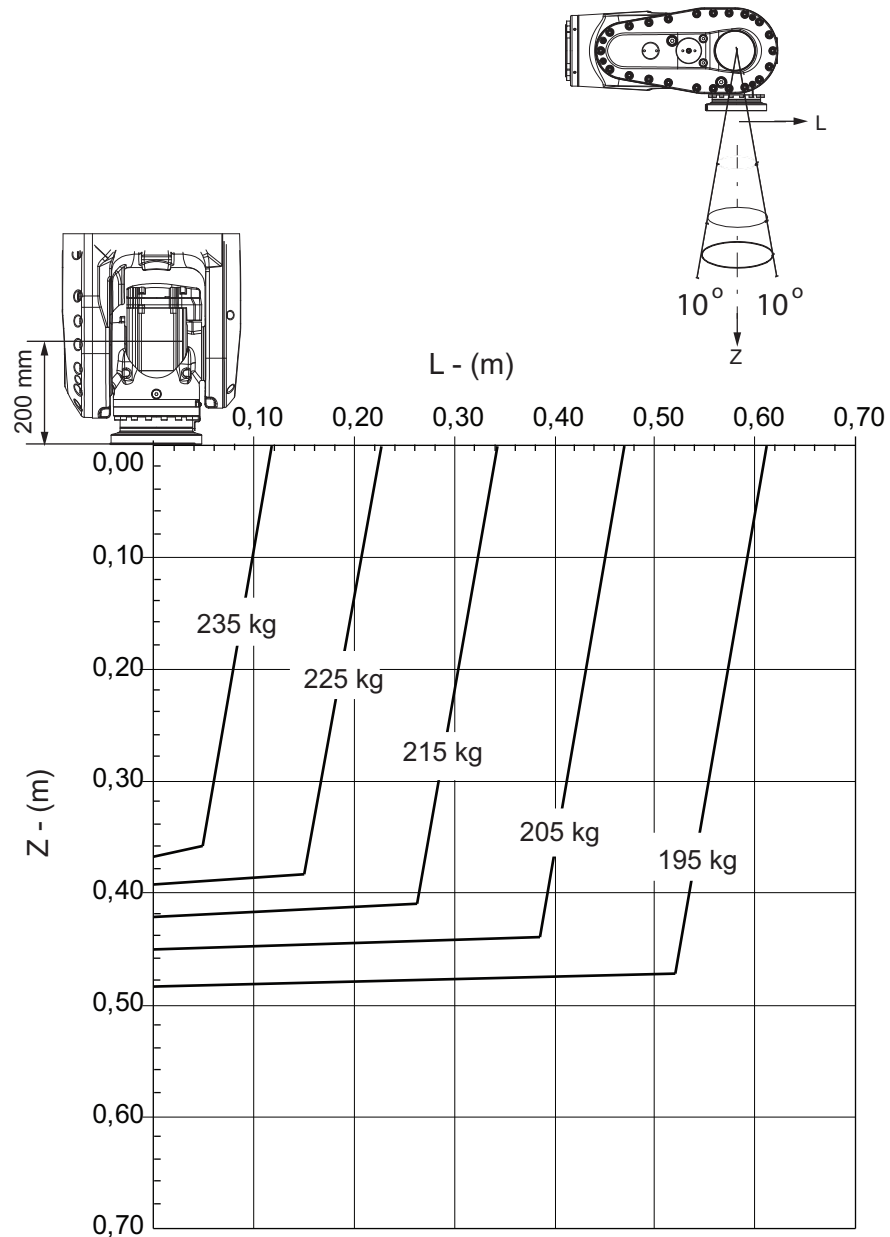

xx1300000250

For wrist down (0° deviation from the vertical line).

	Description
Max load	240 kg
Z _{max}	0.355 m
L _{max}	0.103 m

Continues on next page

1 Description

1.5.2 Diagrams

Continued

IRB 6700-200/2.80 LID

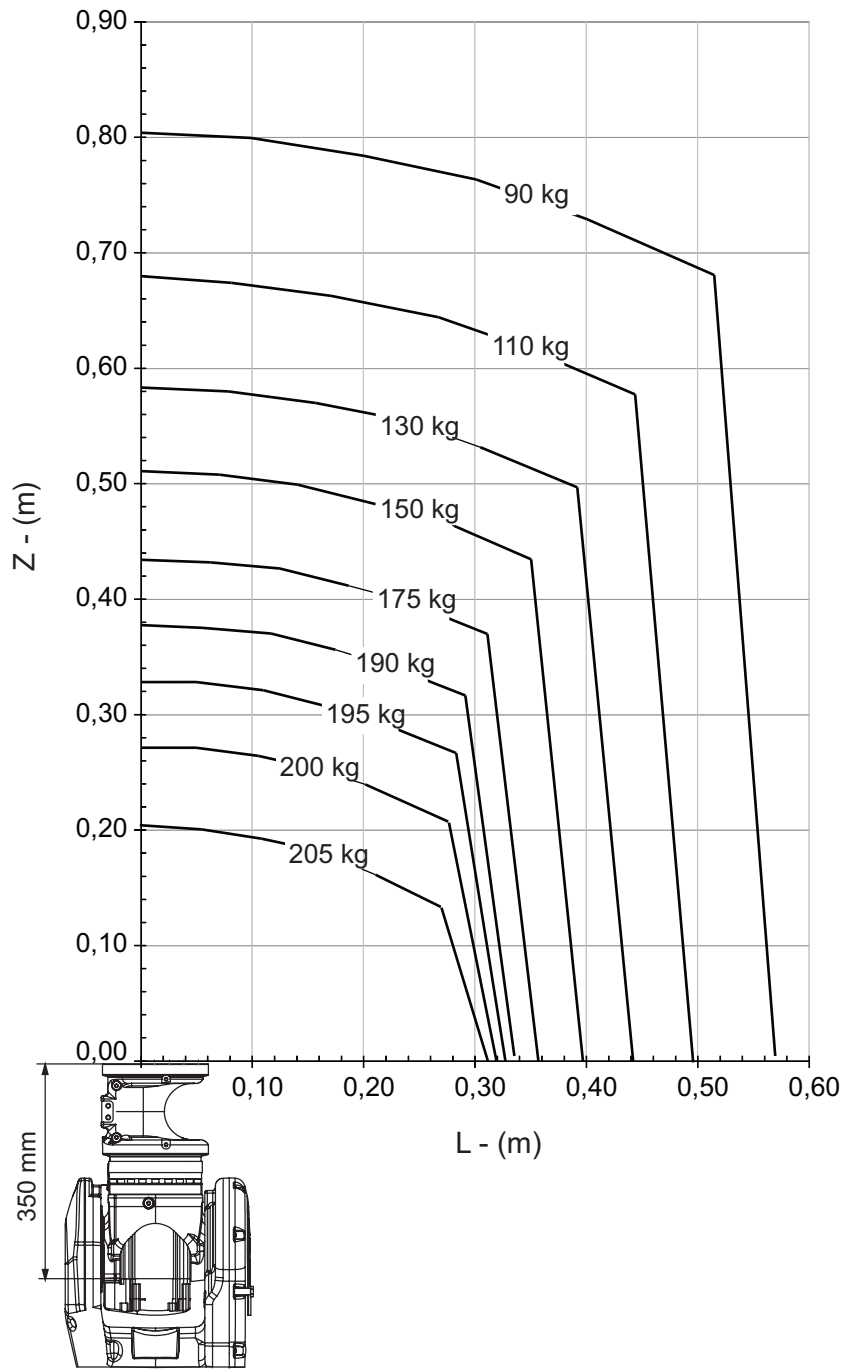

xx1300000251

Continues on next page

IRB 6700-200/2.60

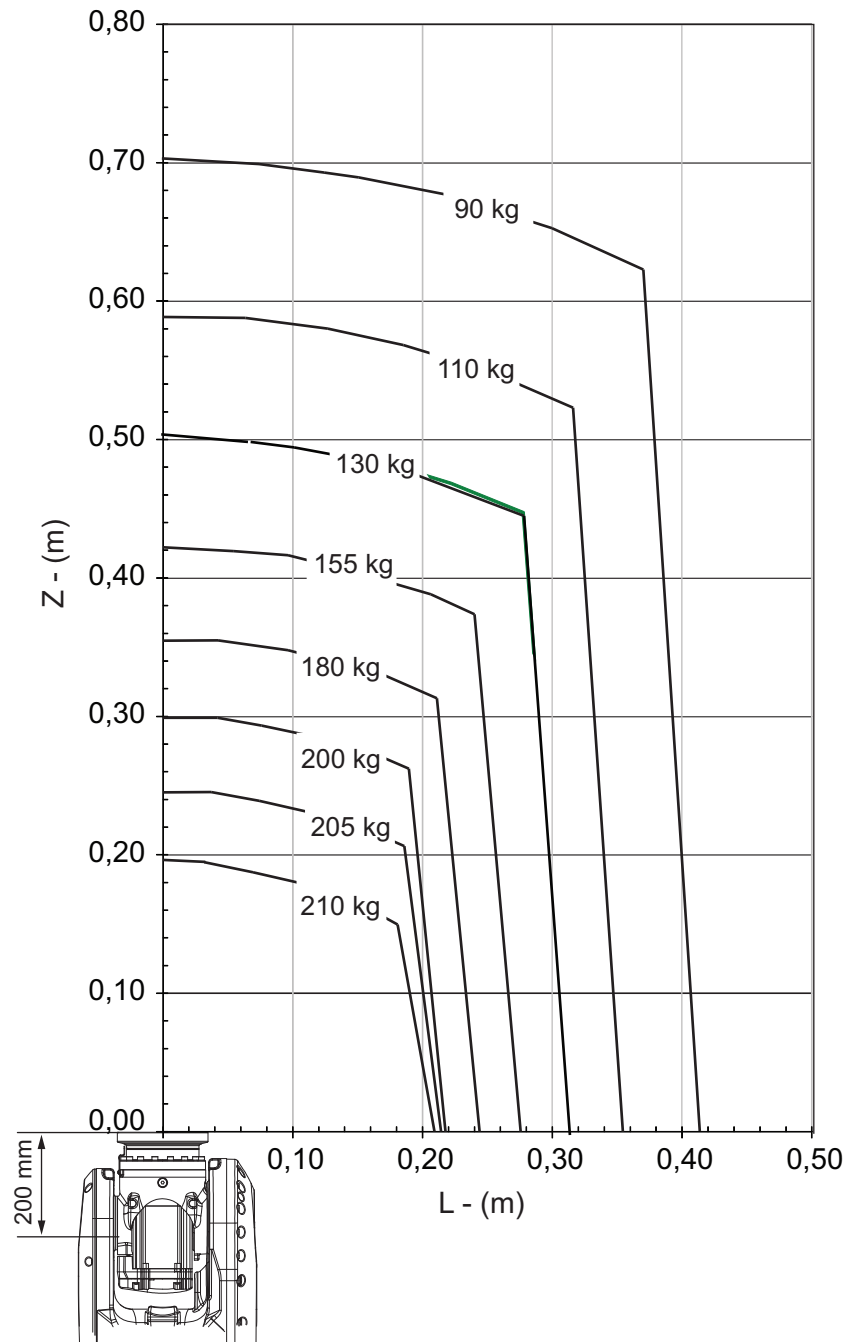

xx130000333

Continues on next page

1 Description

1.5.2 Diagrams

Continued

IRB 6700-200/2.60 "Vertical Wrist" ($\pm 10^\circ$)

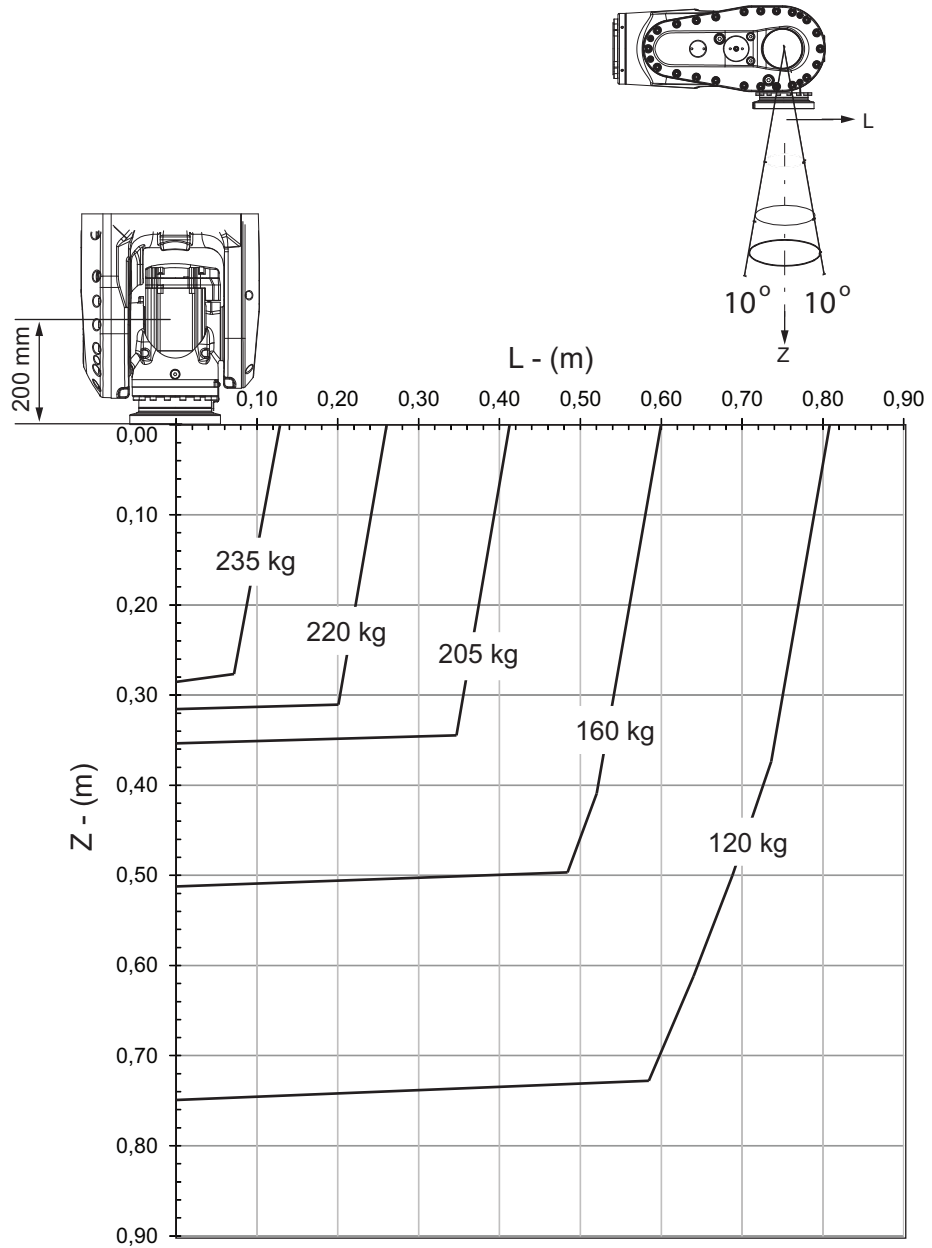

xx1300000334

For wrist down (0° deviation from the vertical line).

	Description
Max load	242 kg
Z _{max}	0.27 m
L _{max}	0.104 m

Continues on next page

IRB 6700-175/2.60 LID

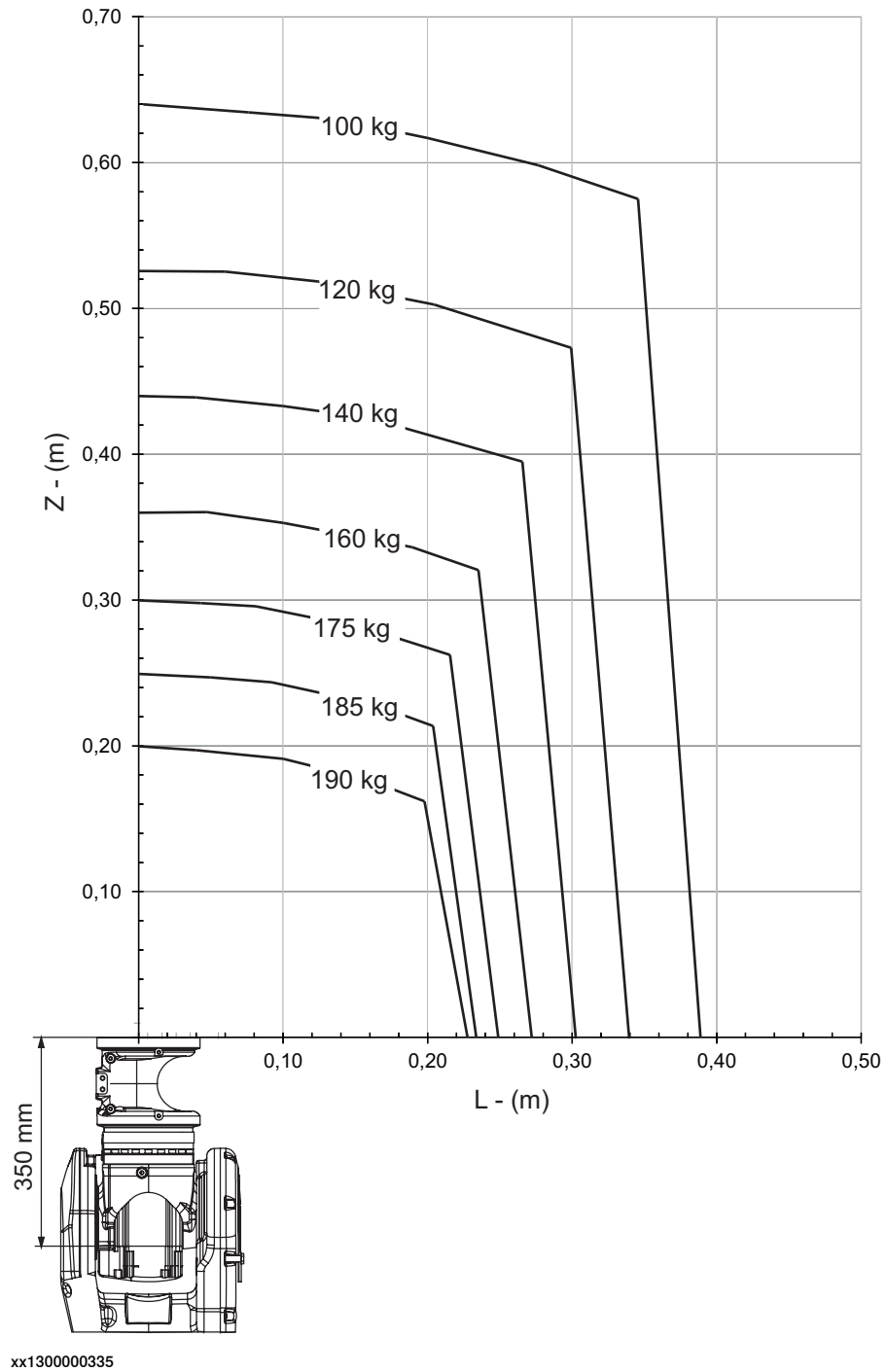

Continues on next page

1 Description

1.5.2 Diagrams

Continued

IRB 6700-175/3.05

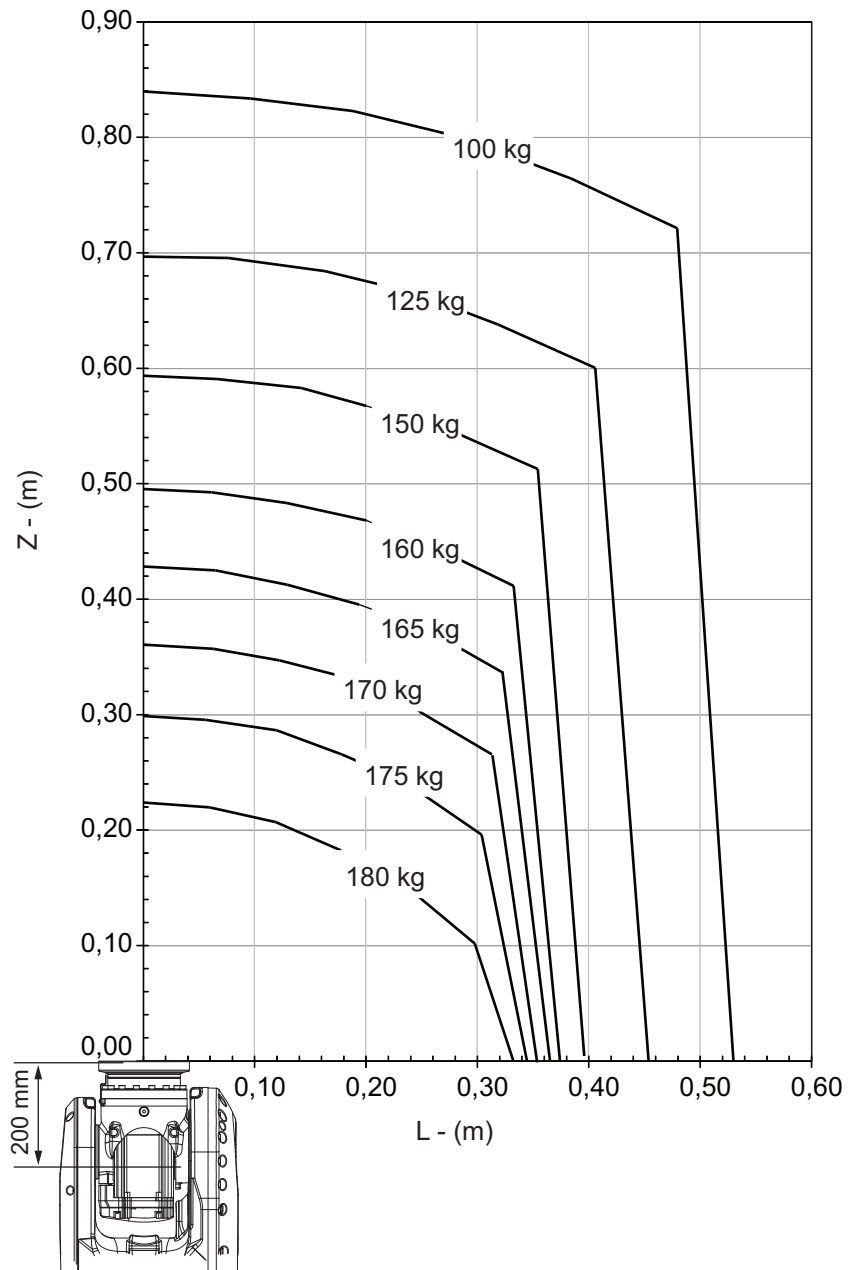

xx1300000252

Continues on next page

IRB 6700-175/3.05 "Vertical Wrist" ($\pm 10^\circ$)

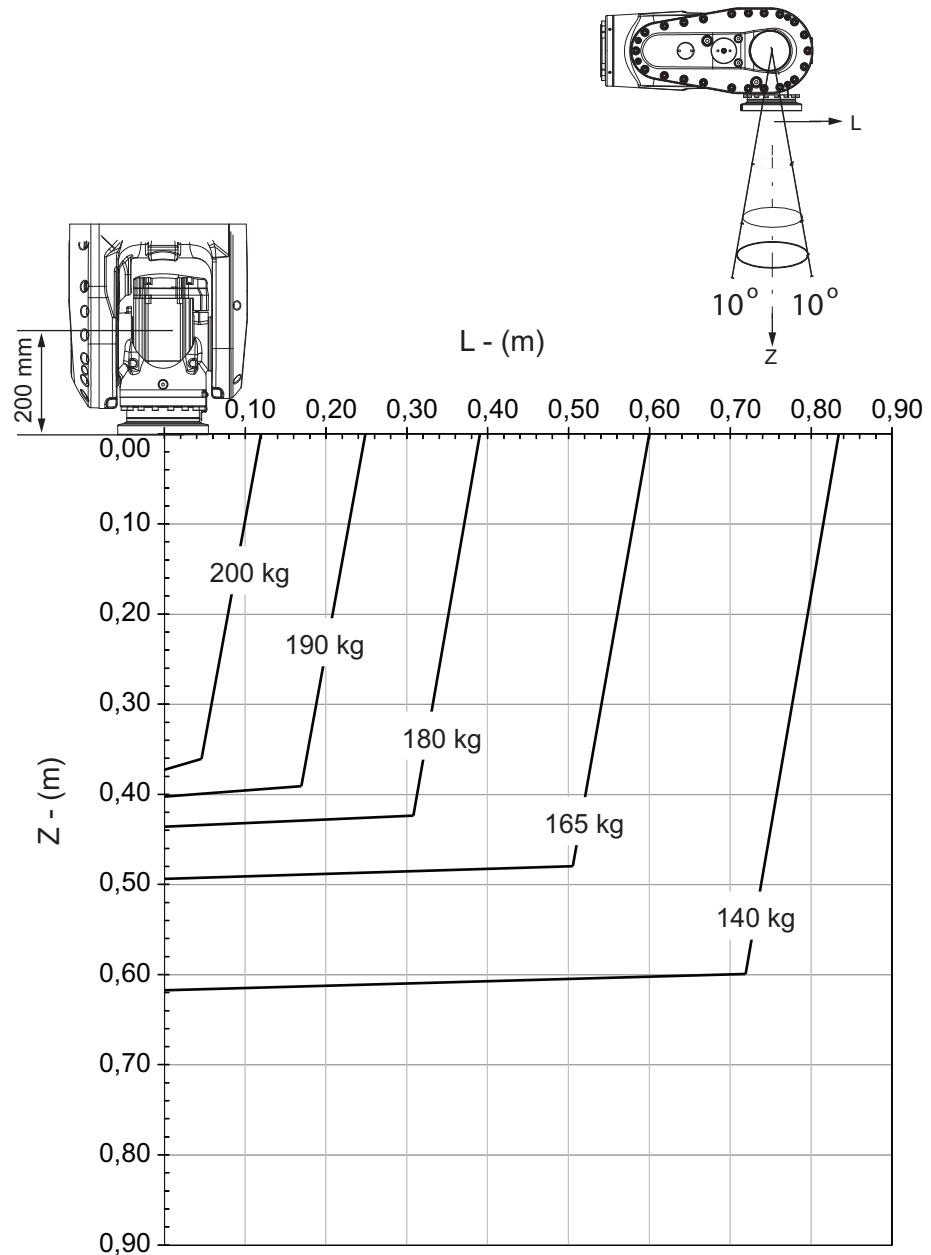

xx1300000253

	Description
Max load	204 kg
Z_{max}	0.360 m
L_{max}	0.101 m

Continues on next page

1 Description

1.5.2 Diagrams

Continued

IRB 6700-155/3.05 LID

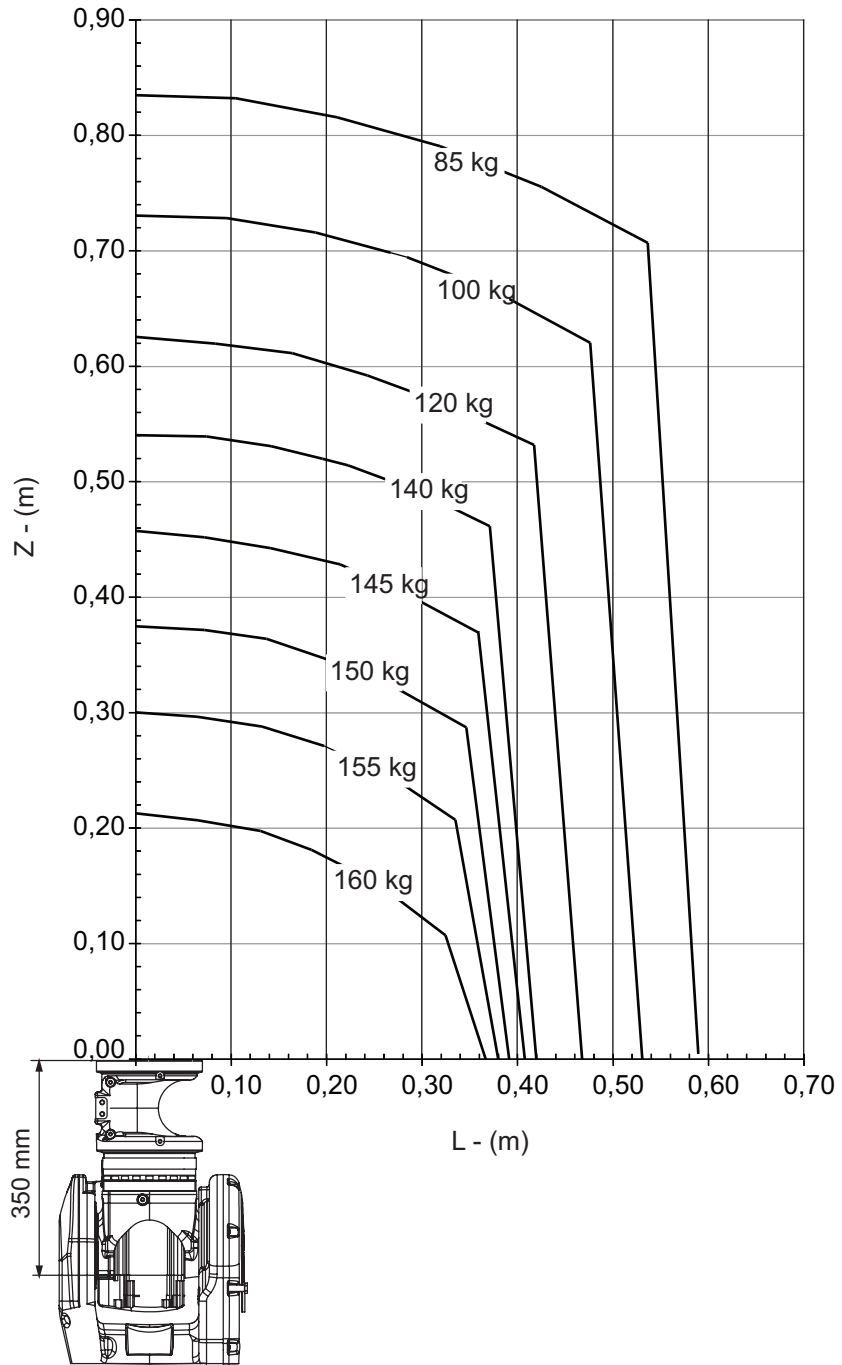

xx130000254

Continues on next page

IRB 6700-155/2.85

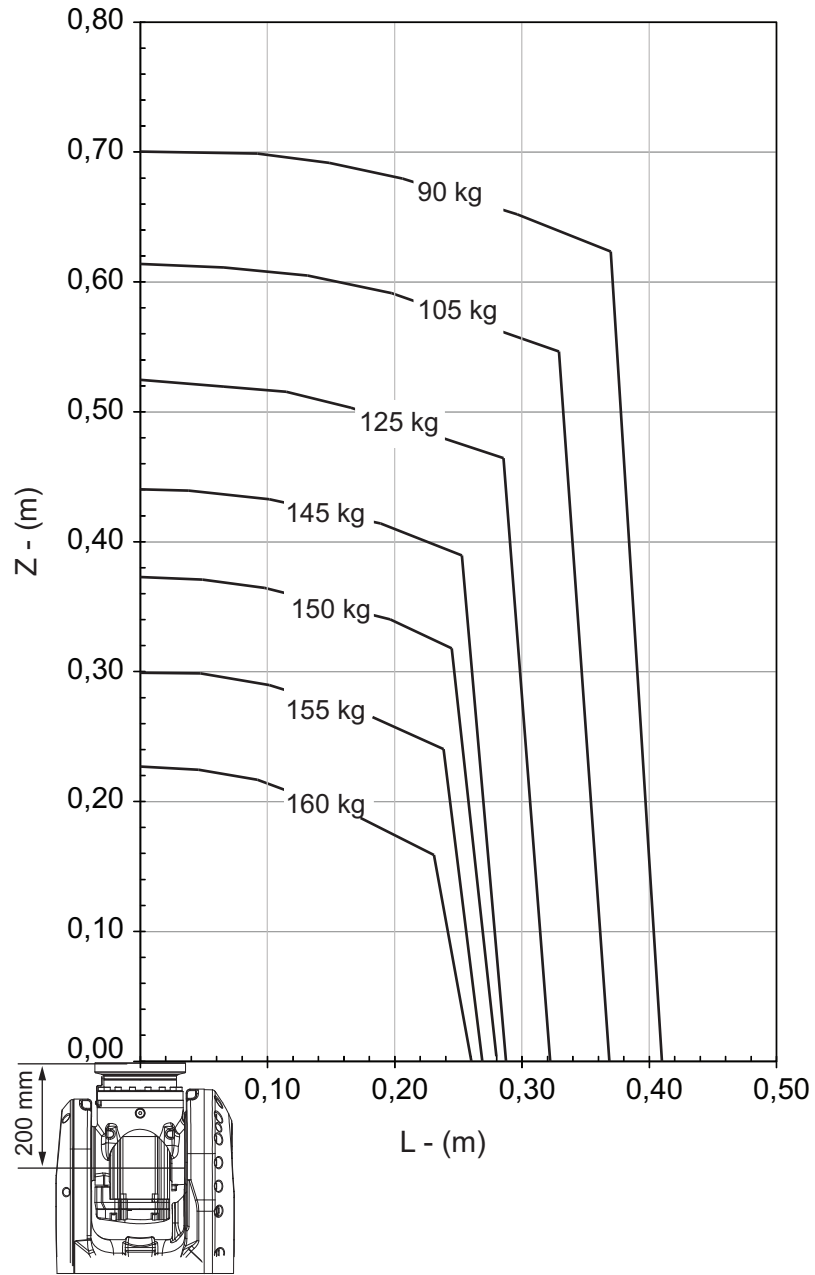

xx1300000336

Continues on next page

1 Description

1.5.2 Diagrams

Continued

IRB 6700-155/2.85 "Vertical Wrist" ($\pm 10^\circ$)

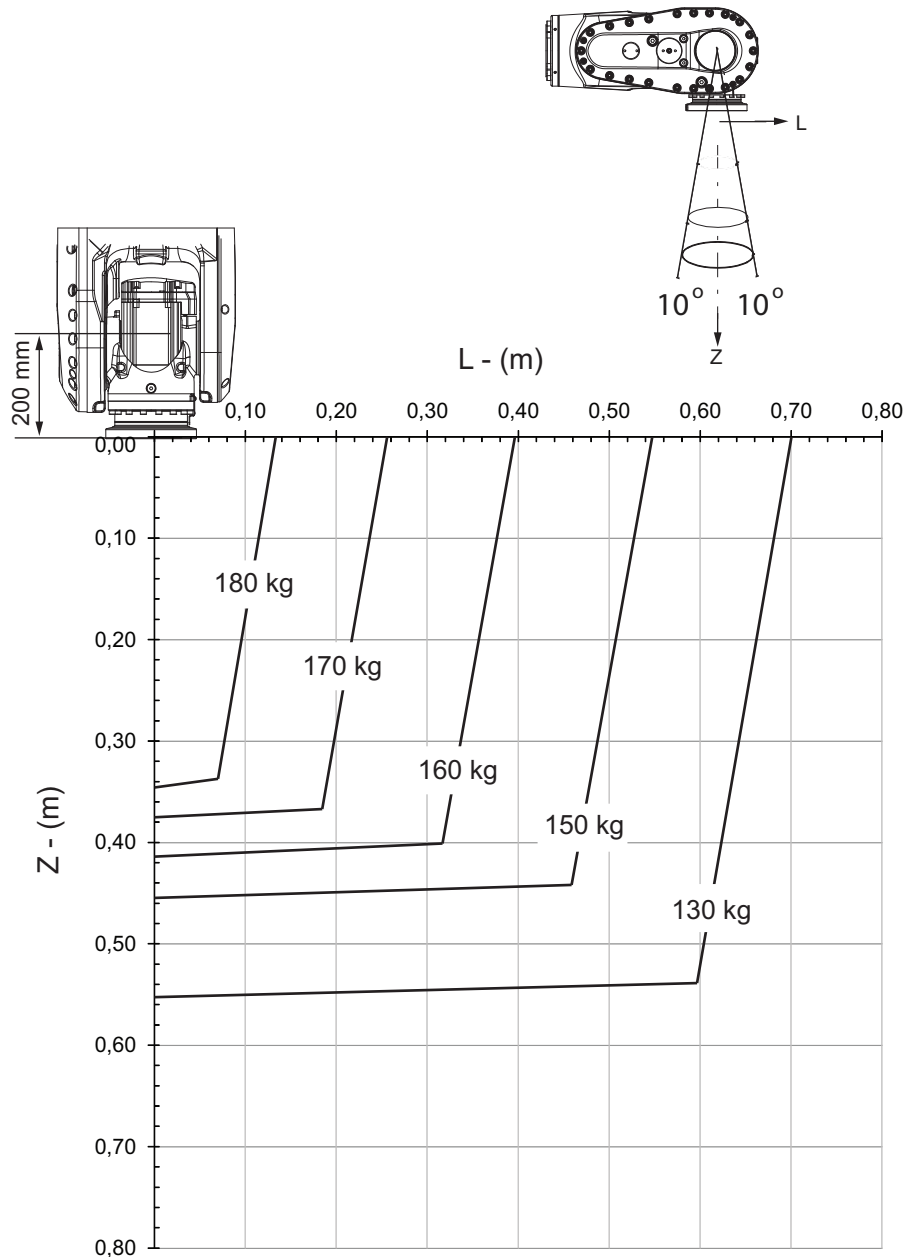

xx1300000337

	Description
Max load	186 kg
Z _{max}	0.327 m
L _{max}	0.101 m

Continues on next page

IRB 6700-140/2.85 LID

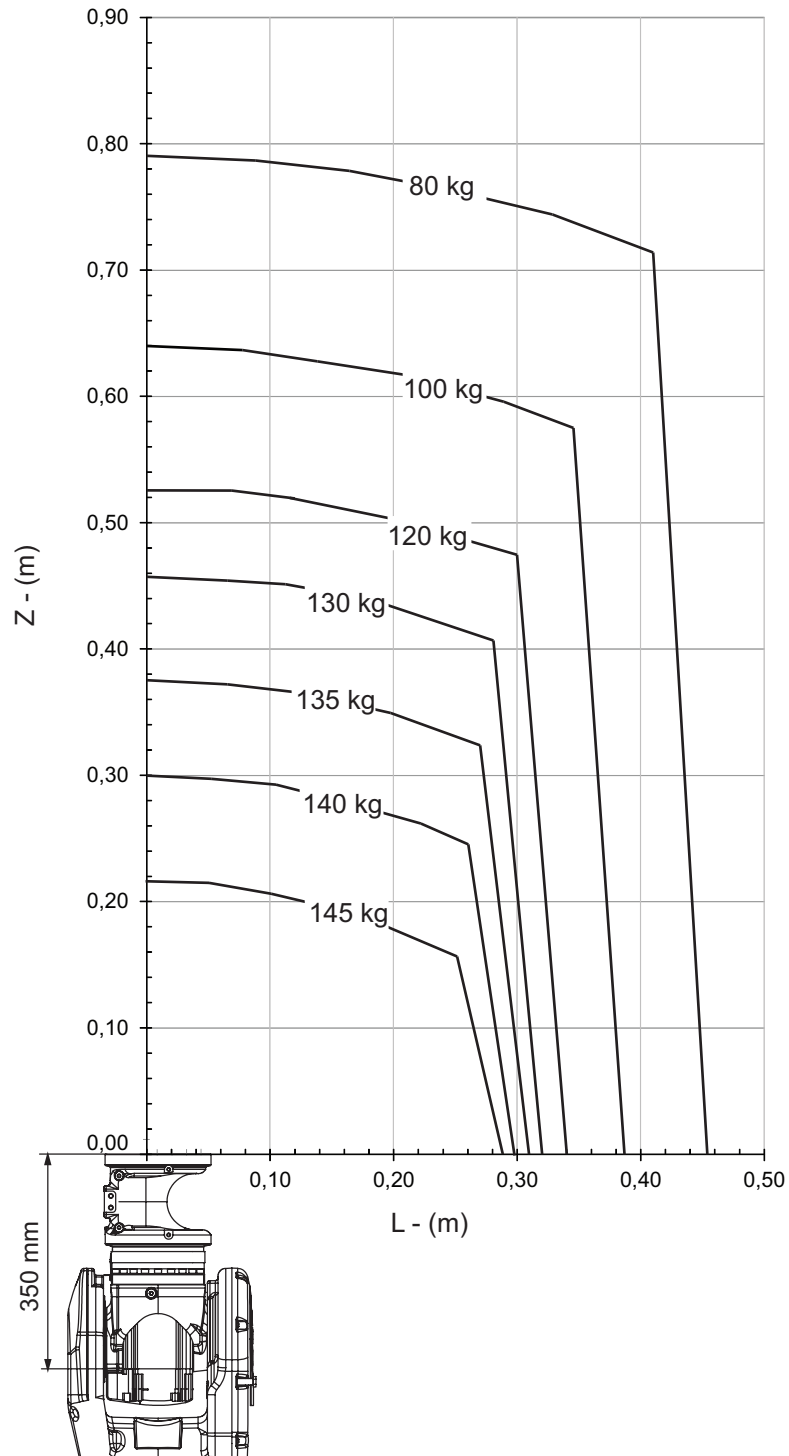

xx1300000338

Continues on next page

1 Description

1.5.2 Diagrams

Continued

IRB 6700-150/3.20

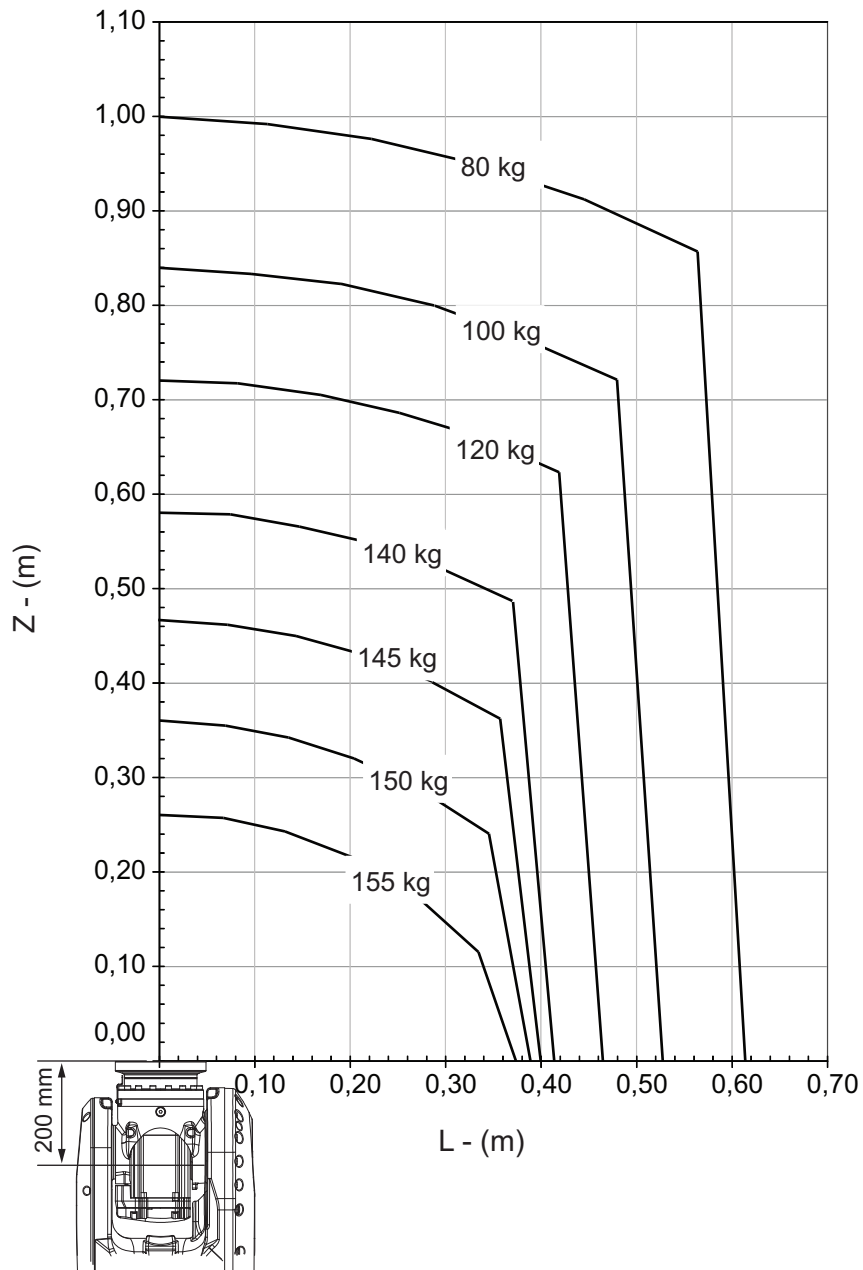

xx1300000255

Continues on next page

IRB 6700-150/3.20 "Vertical Wrist" ($\pm 10^\circ$)

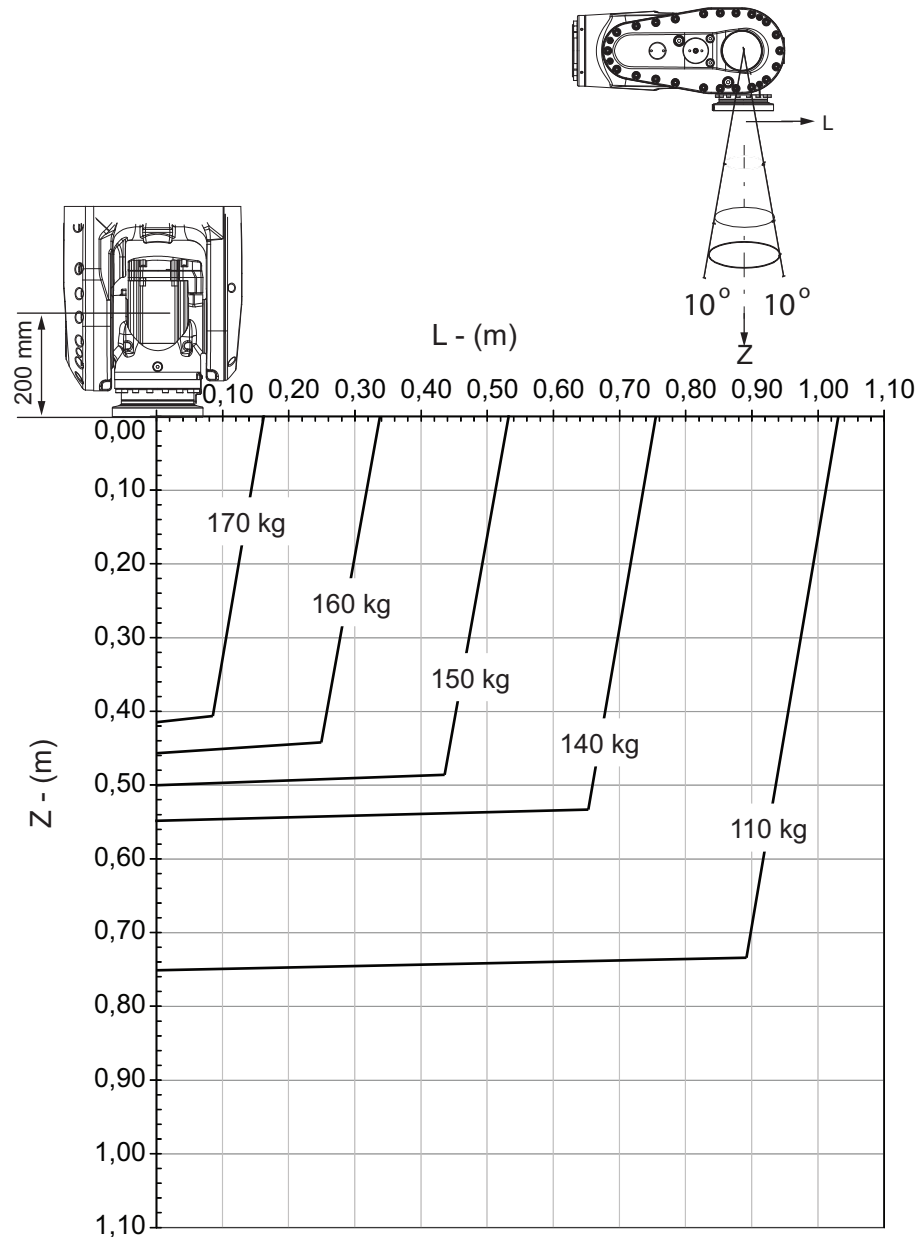

xx1300000256

For wrist down (0° deviation from the vertical line).

	Description
Max load	177 kg
Z _{max}	0.394 m
L _{max}	0.106 m

Continues on next page

1 Description

1.5.2 Diagrams

Continued

IRB 6700-145/3.20 LID

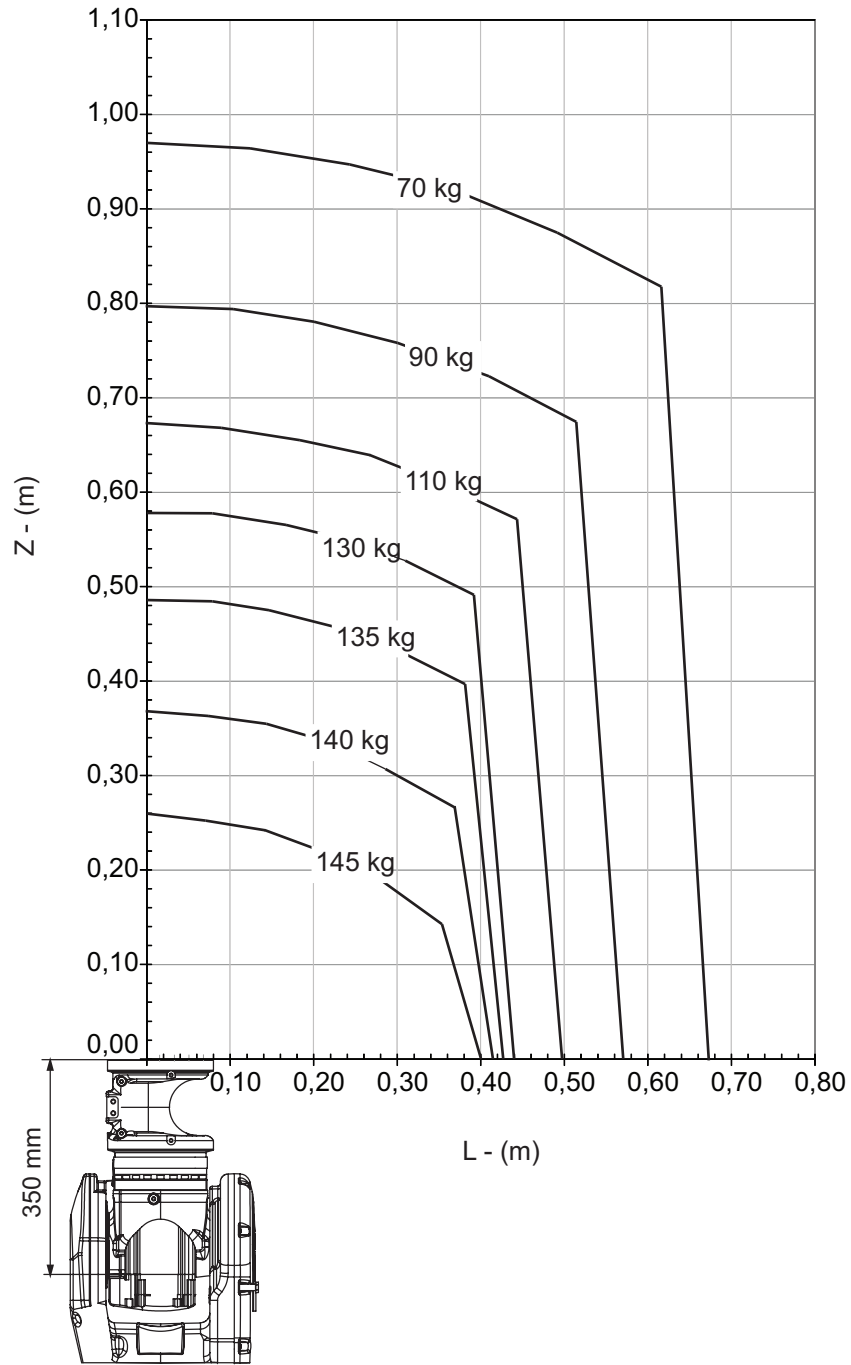

xx1300000257

Continues on next page

IRB 6700-300/2.70

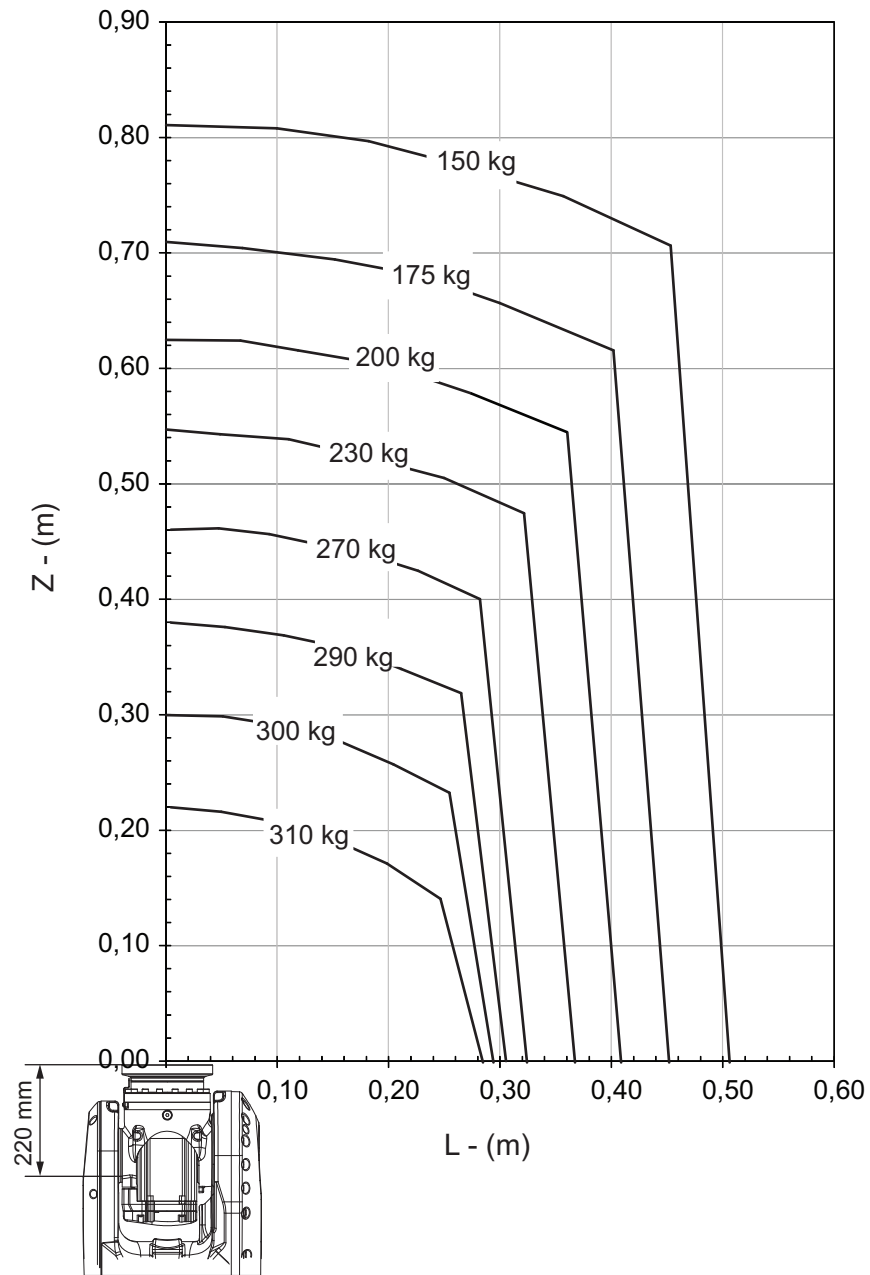

xx1400002044

Continues on next page

1 Description

1.5.2 Diagrams

Continued

IRB 6700-300/2.70 "Vertical Wrist" ($\pm 10^\circ$)

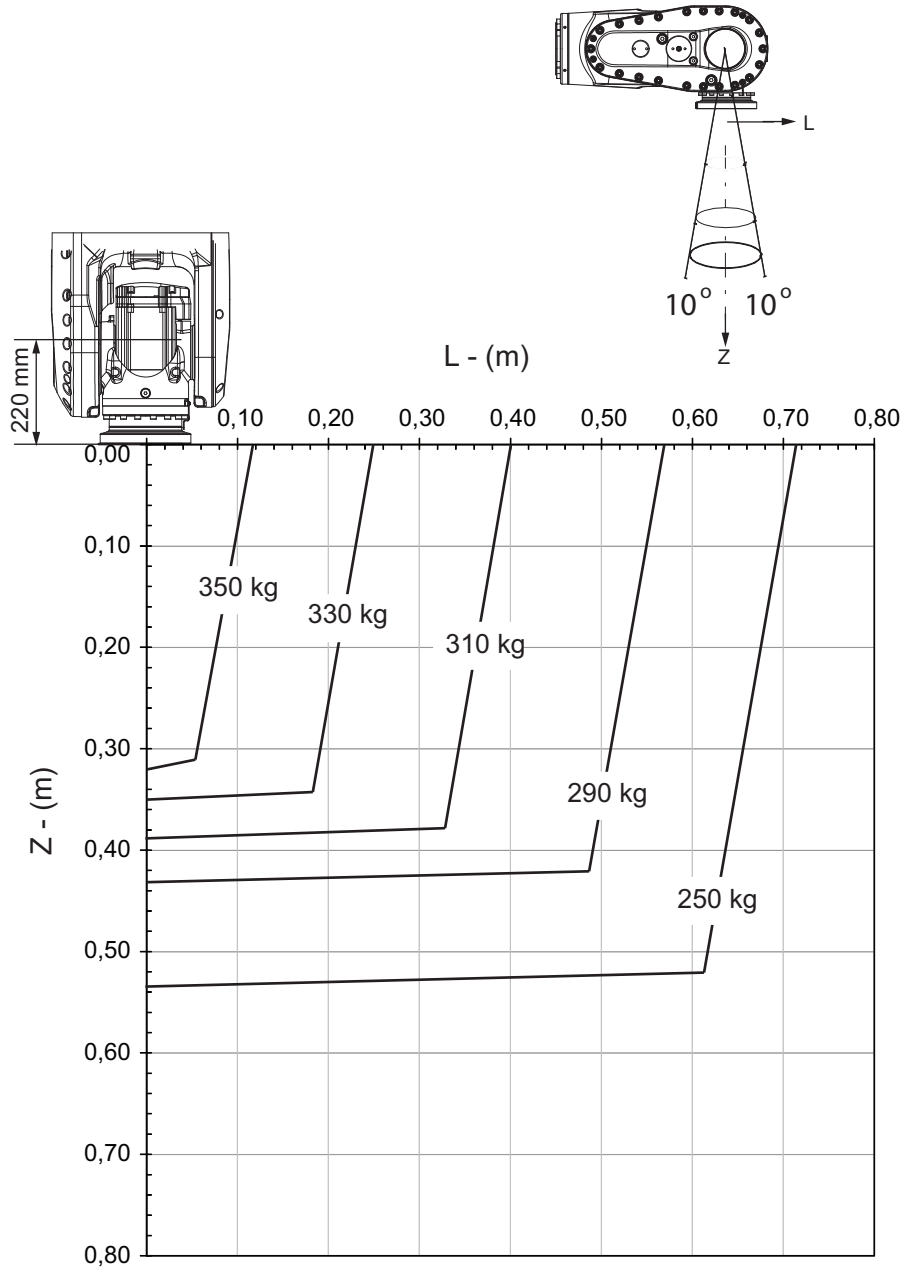

xx1400002045

For wrist down (0° deviation from the vertical line).

	Description
Max load	357 kg
Z _{max}	0.308 m
L _{max}	0.102 m

Continues on next page

IRB 6700-270/2.70 LID

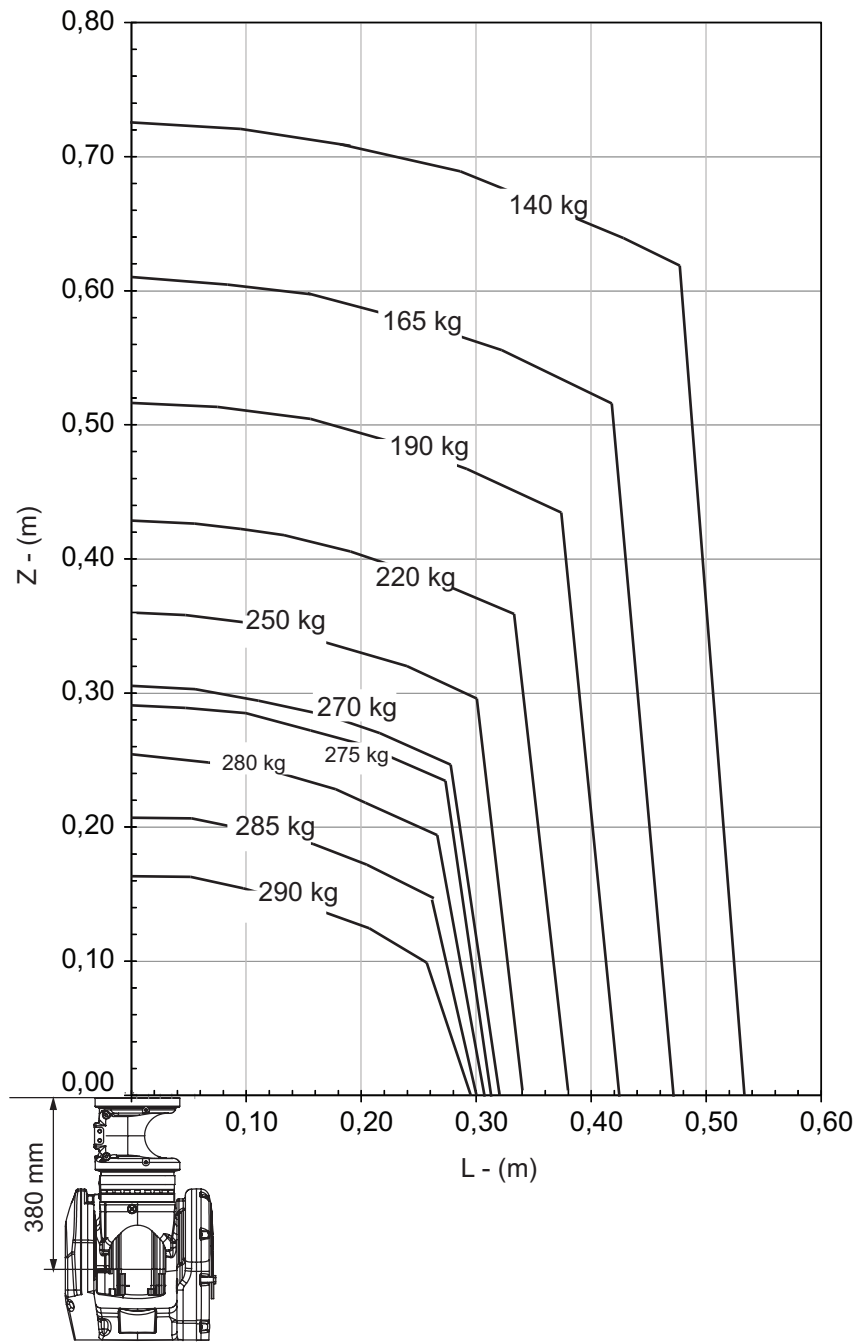

xx1400002046

Continues on next page

1 Description

1.5.2 Diagrams

Continued

IRB 6700-245/3.00

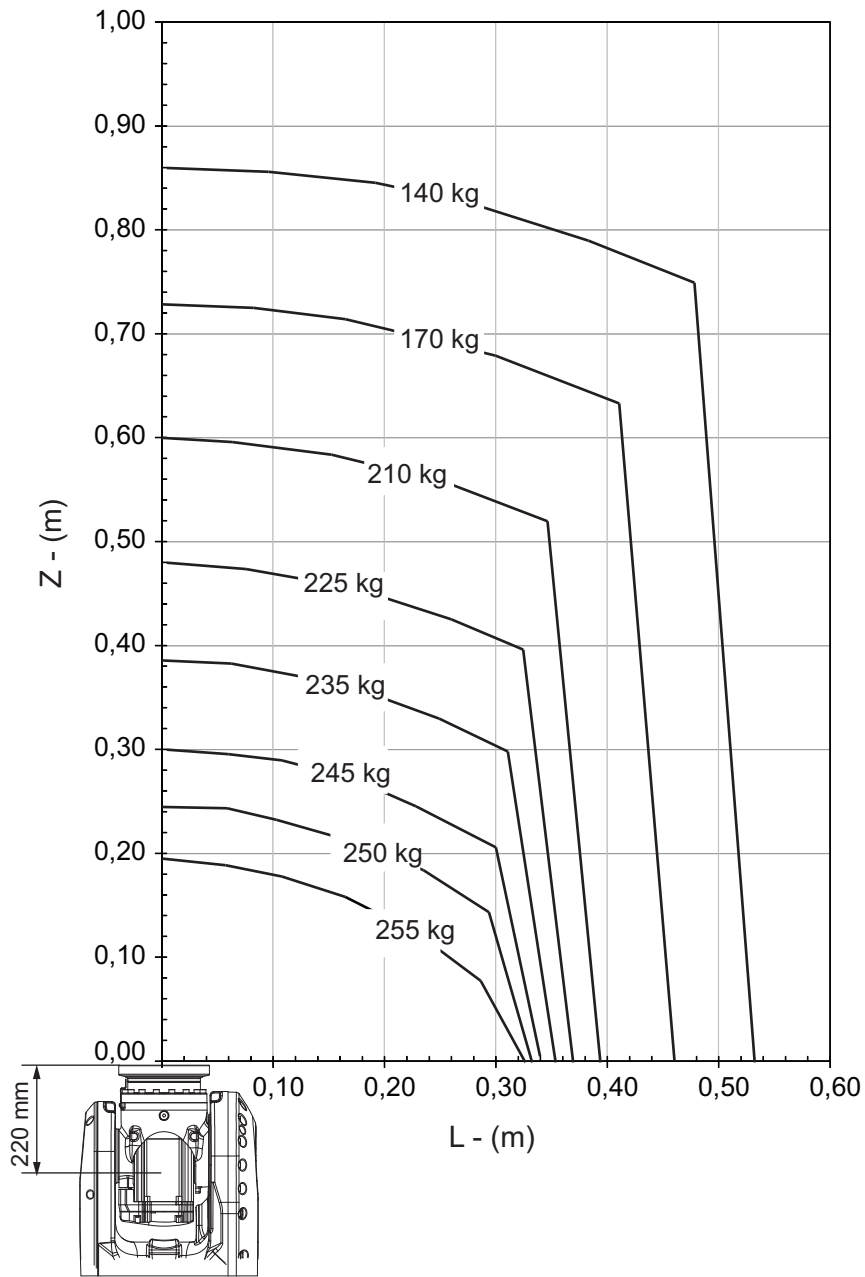

xx1400002041

Continues on next page

IRB 6700-245/3.00 "Vertical Wrist" ($\pm 10^\circ$)

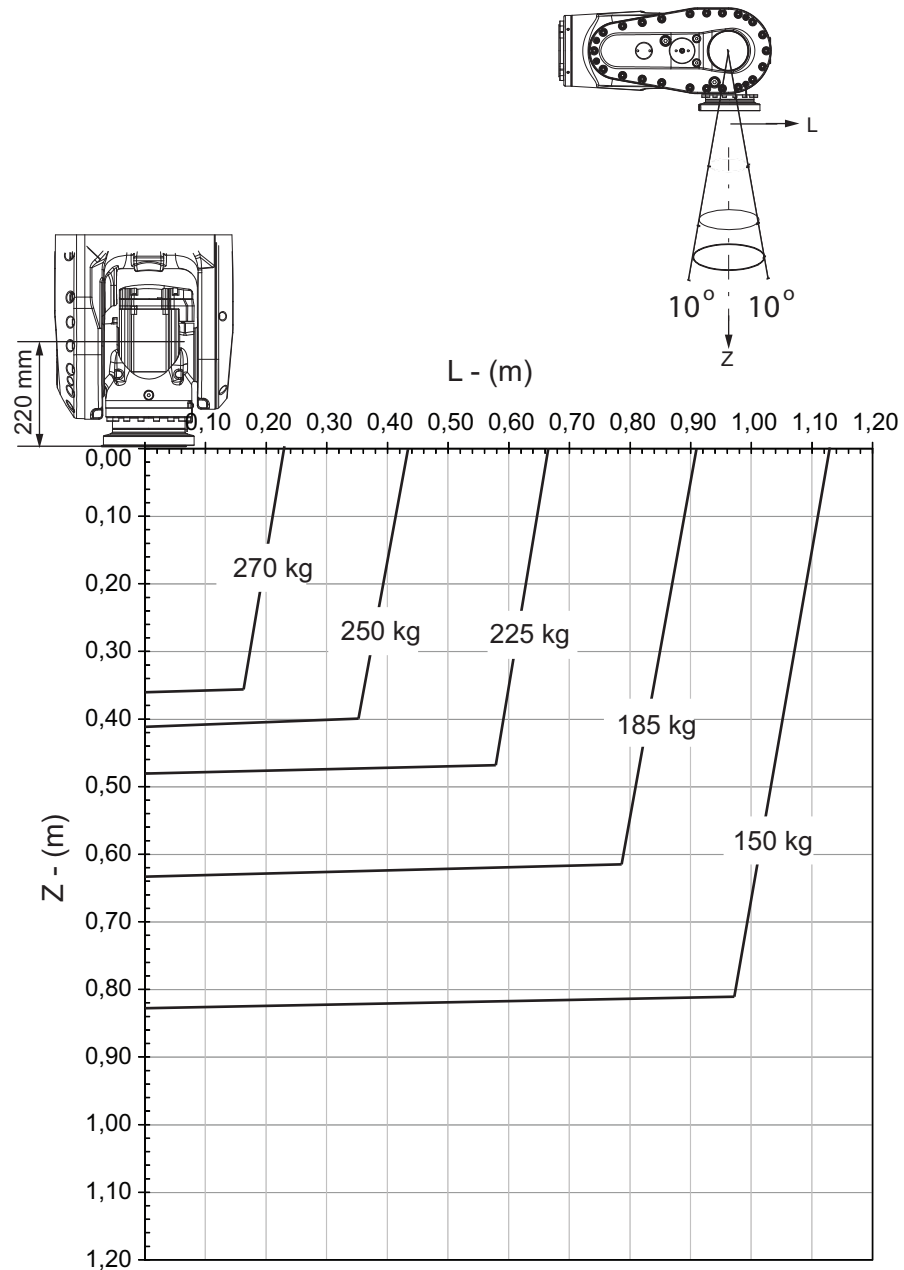

xx1400002042

For wrist down (0° deviation from the vertical line).

	Description
Max load	315 kg
Z _{max}	0.280 m
L _{max}	0.102 m

Continues on next page

1 Description

1.5.2 Diagrams

Continued

IRB 6700-220/3.00 LID

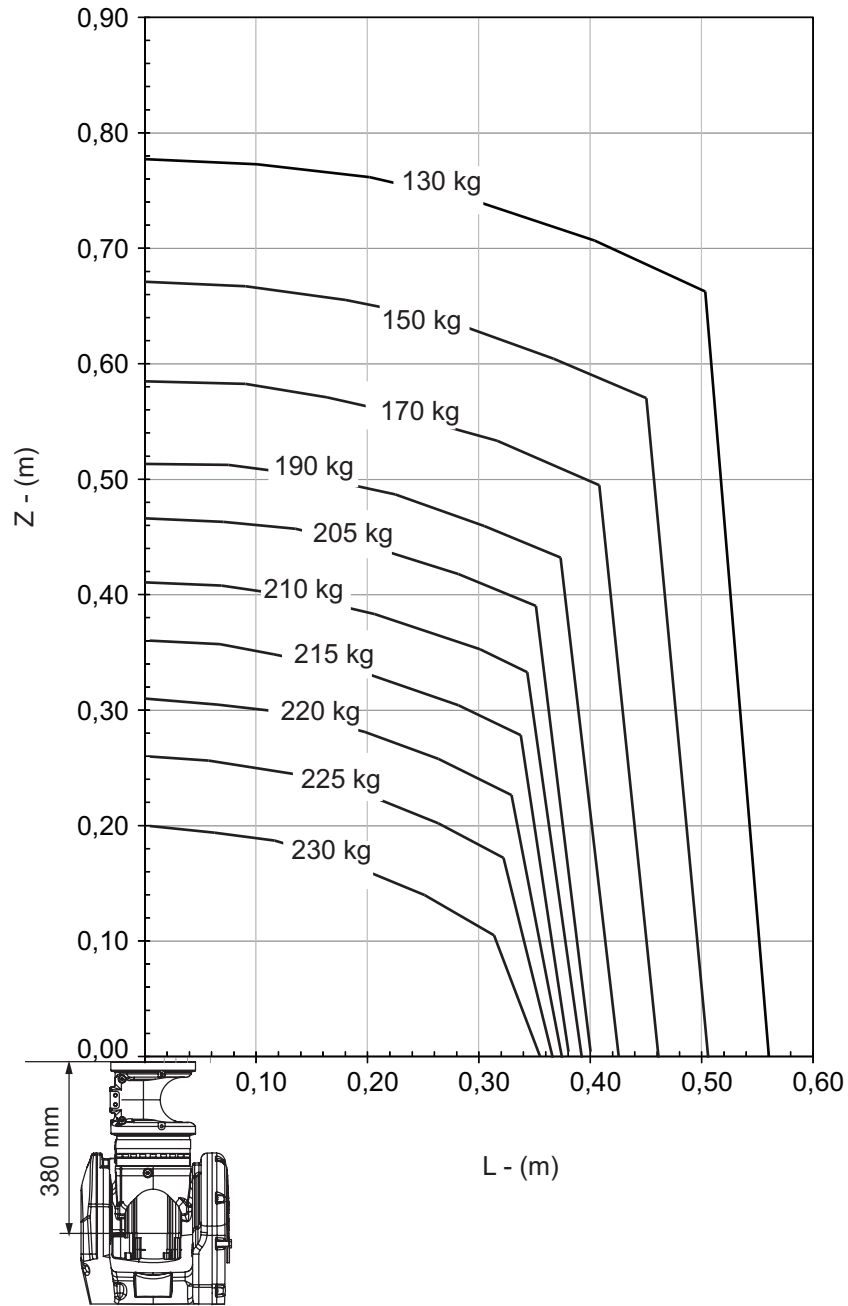

xx1400002043

Continues on next page

IRB 6700I-300/2.60

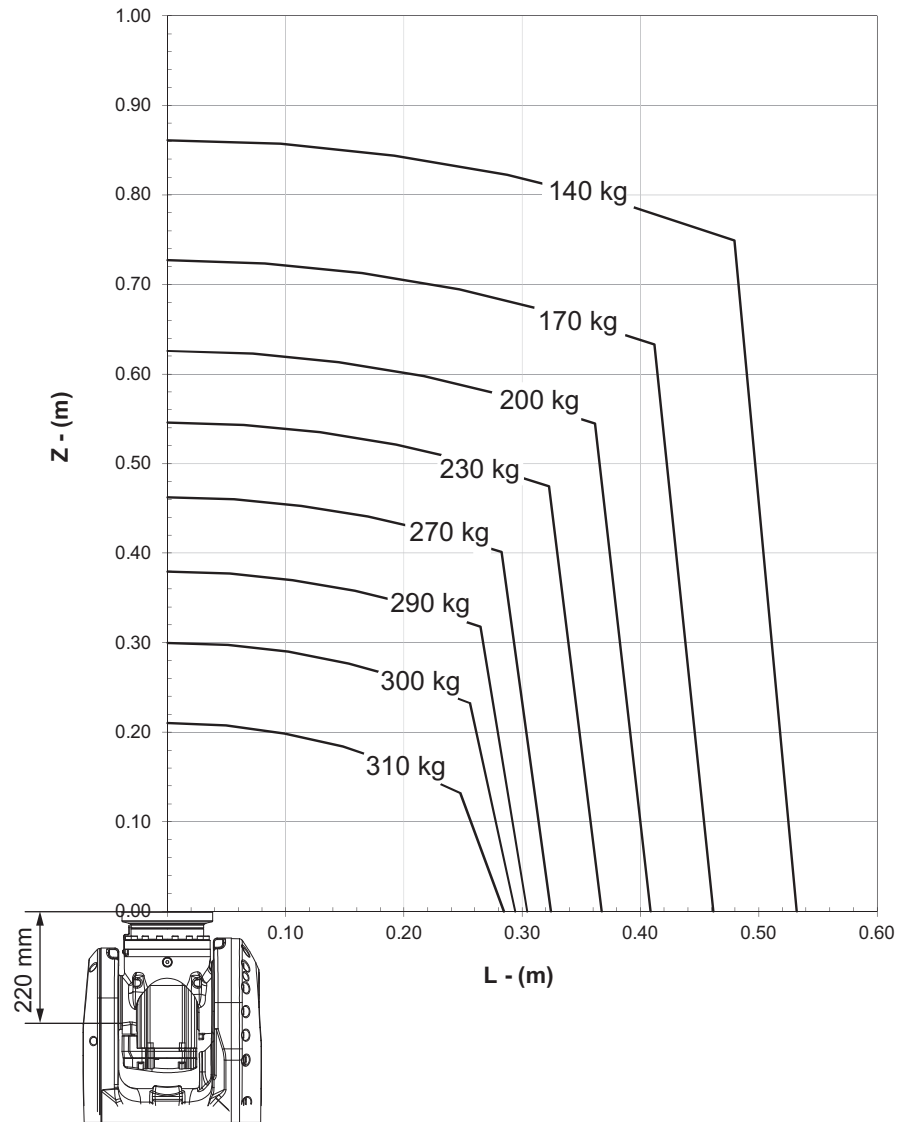

xx1600002017

Continues on next page

1 Description

1.5.2 Diagrams

Continued

"Vertical Wrist" ($\pm 10^\circ$) IRB 6700I-300/2.60

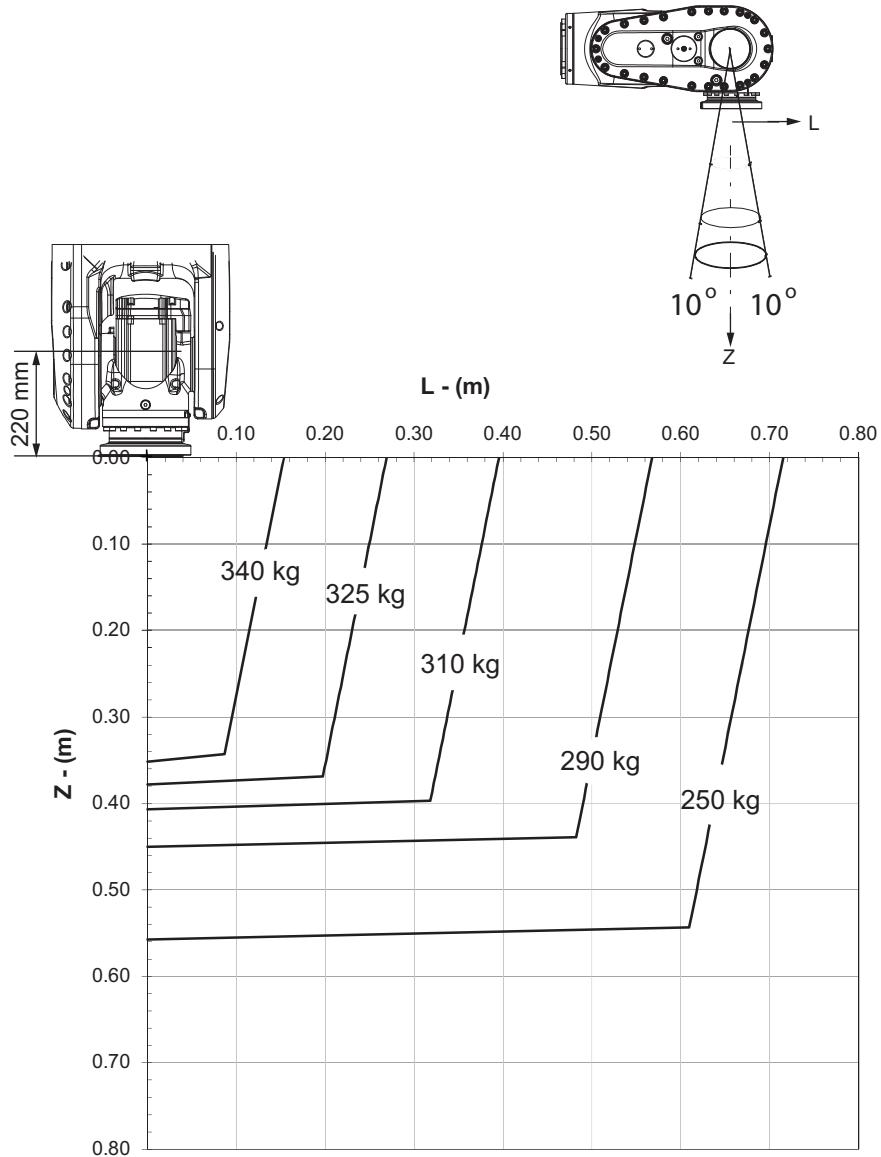

xx1600002018

For wrist down (0° deviation from the vertical line).

	Description
Max load	352 kg
Z _{max}	0.332 m
L _{max}	0.105 m

Continues on next page

IRB 6700I-270/2.60 LID

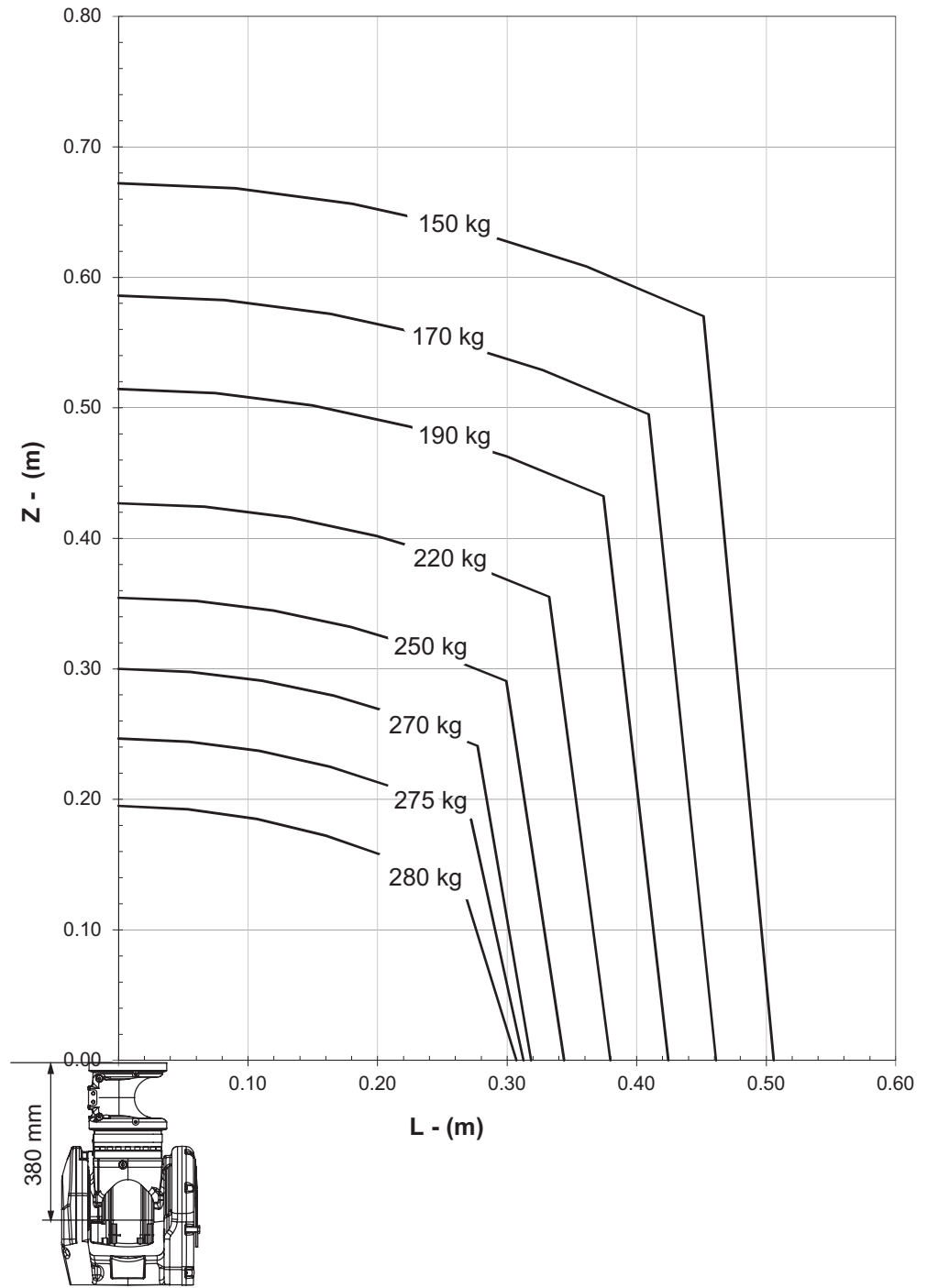

xx1600002050

Continues on next page

1 Description

1.5.2 Diagrams

Continued

IRB 6700I-245/2.90

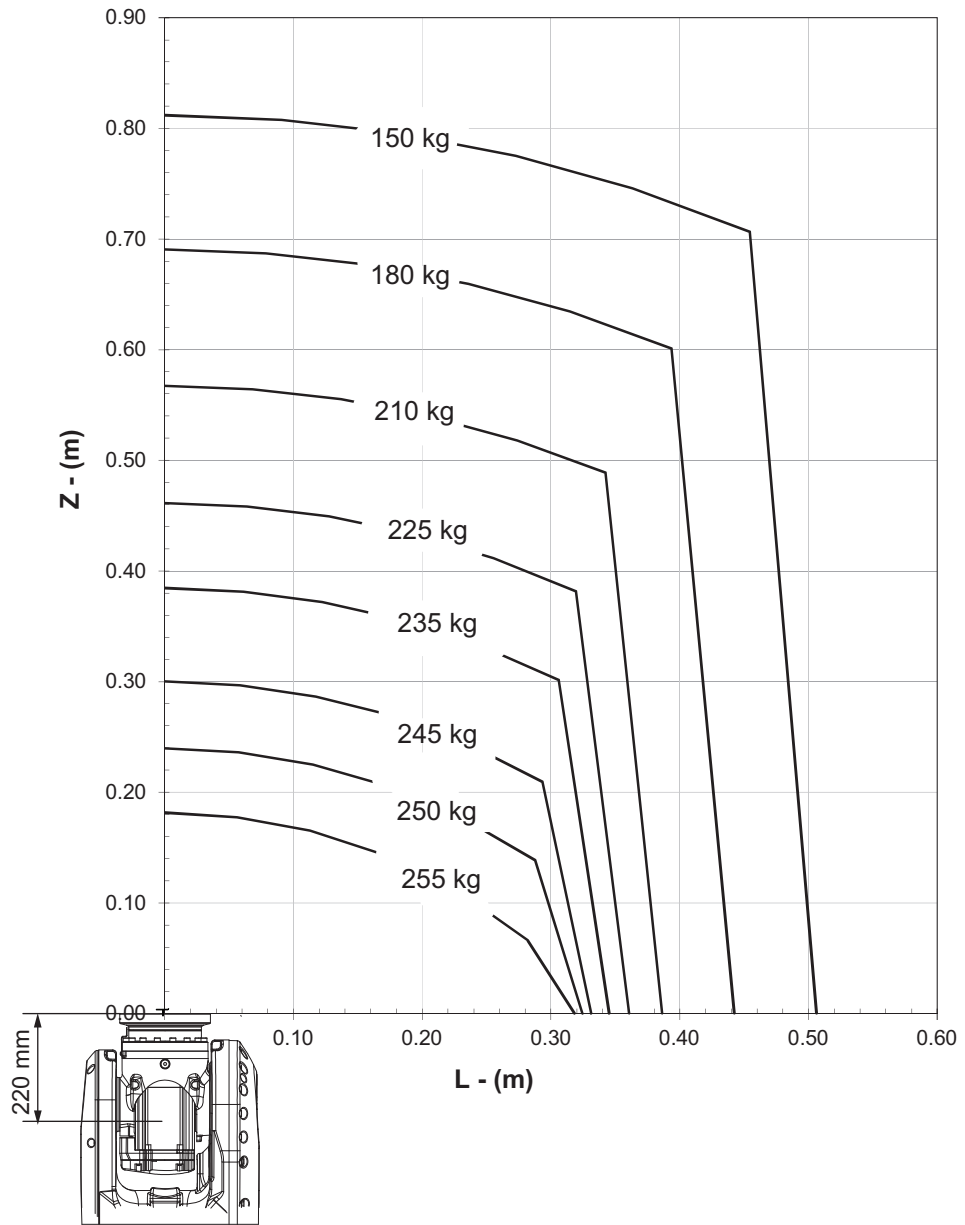

xx1600002019

Continues on next page

"Vertical Wrist" ($\pm 10^\circ$) IRB 6700I-245/2.90

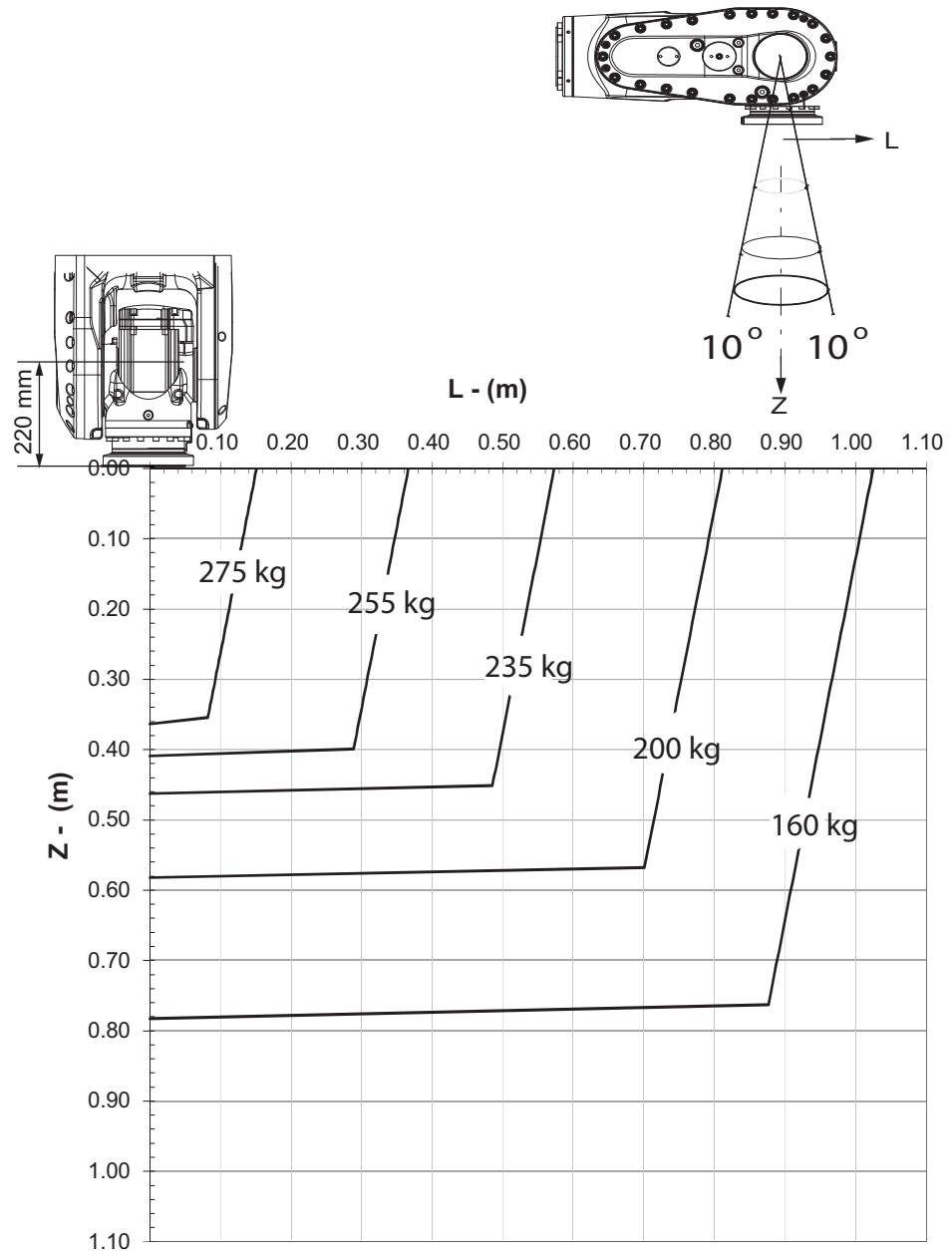

xx1600002020

For wrist down (0° deviation from the vertical line).

	Description
Max load	284 kg
Z _{max}	0.345 m
L _{max}	0.101 m

Continues on next page

1 Description

1.5.2 Diagrams

Continued

IRB 6700I-210/2.90 LID

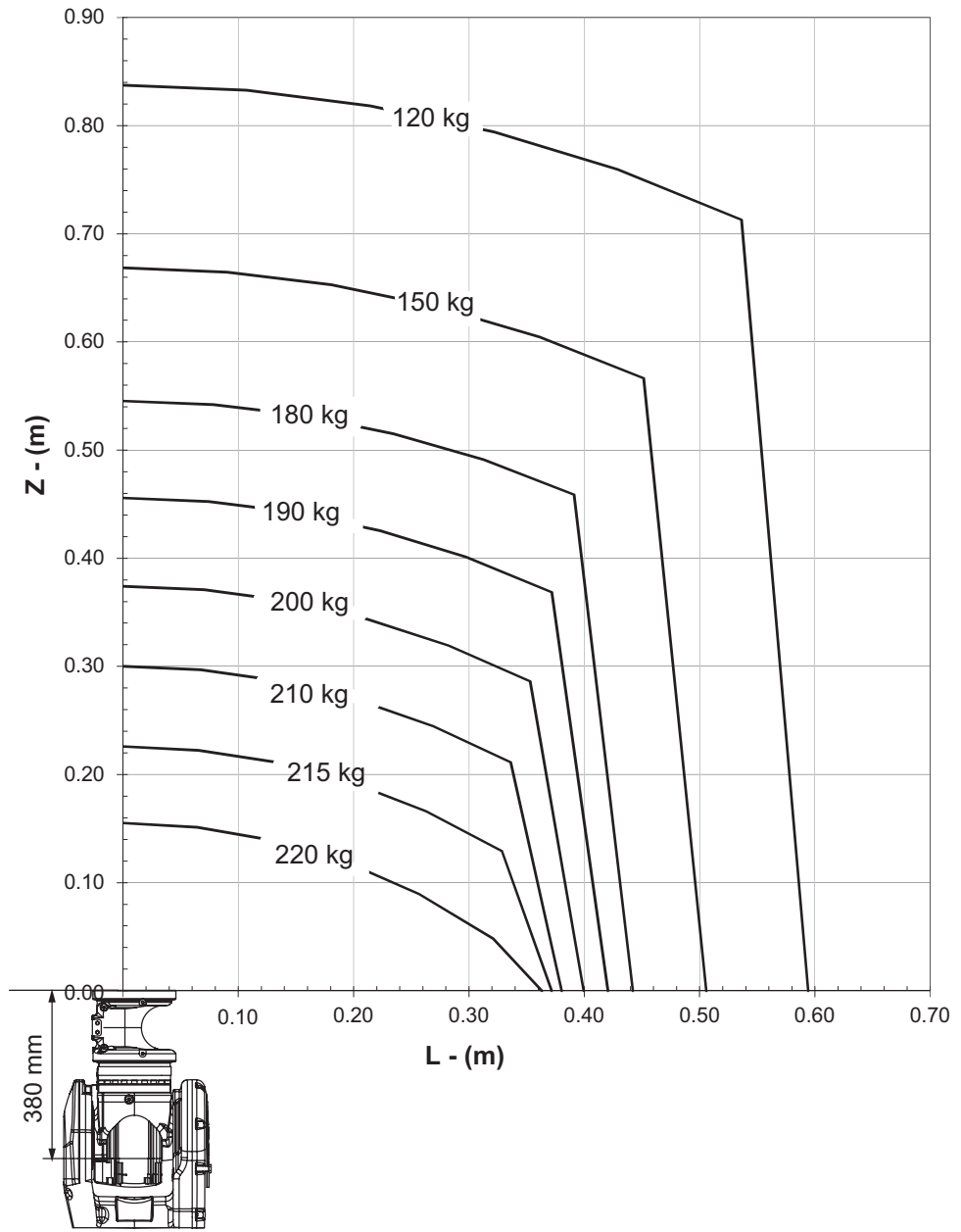

xx1600002051

1.5.3 Maximum load and moment of inertia for full and limited axis 5 (center line down) movement

1.5.3 Maximum load and moment of inertia for full and limited axis 5 (center line down) movement



Note

Total load given as: mass in kg, center of gravity (Z and L) in meters and moment of inertia (J_{0x} , J_{0y} , J_{0z}) in kgm^2 . $L = \text{sqr}(X^2 + Y^2)$, see the following figure.

Full movement of axis 5 ($\pm 130^\circ$)

Axis	Robot type	Maximum moment of inertia
5	IRB 6700-235/2.65 IRB 6700-205/2.80 IRB 6700-175/3.05 IRB 6700-150/3.20	$J_{a5} = \text{Load} \times ((Z + 0.200)^2 + L^2) + \max(J_{0x}, J_{0y}) \leq 250 \text{ kgm}^2$
	IRB 6700-220/2.65 LID IRB 6700-200/2.80 LID IRB 6700-155/3.05 LID IRB 6700-145/3.20 LID	$J_{a5} = \text{Load} \times ((Z + 0.350)^2 + L^2) + \max(J_{0x}, J_{0y}) \leq 250 \text{ kgm}^2$
	IRB 6700-200/2.60 IRB 6700-155/2.85	$J_{a5} = \text{Load} \times ((Z + 0.200)^2 + L^2) + \max(J_{0x}, J_{0y}) \leq 195 \text{ kgm}^2$
	IRB 6700-175/2.60 LID IRB 6700-140/2.85 LID	$J_{a5} = \text{Load} \times ((Z + 0.350)^2 + L^2) + \max(J_{0x}, J_{0y}) \leq 195 \text{ kgm}^2$
	IRB 6700-300/2.70 IRB 6700-245/3.00 IRB 6700I-300/2.60 IRB 6700I-245/2.90	$J_{a5} = \text{Load} \times ((Z + 0.220)^2 + L^2) + \max(J_{0x}, J_{0y}) \leq 325 \text{ kgm}^2$
	IRB 6700-270/2.70 LID IRB 6700-220/3.00 LID IRB 6700I-270/2.60 LID IRB 6700I-210/2.90 LID	$J_{a5} = \text{Load} \times ((Z + 0.380)^2 + L^2) + \max(J_{0x}, J_{0y}) \leq 325 \text{ kgm}^2$

Continues on next page

1 Description

1.5.3 Maximum load and moment of inertia for full and limited axis 5 (center line down) movement

Continued

Axis	Robot type	Maximum moment of inertia	
6	IRB 6700-235/2.65	$Ja_6 = \text{Load} \times L^2 + J_{0Z} \leq 185 \text{ kgm}^2$	
	IRB 6700-220/2.65 LID		
	IRB 6700-205/2.80		
	IRB 6700-200/2.80 LID		
	IRB 6700-175/3.05		
	IRB 6700-155/3.05 LID		
	IRB 6700-150/3.20		
	IRB 6700-145/3.20 LID		
	IRB 6700-200/2.60		$Ja_6 = \text{Load} \times L^2 + J_{0Z} \leq 145 \text{ kgm}^2$
	IRB 6700-175/2.60 LID		
IRB 6700-155/2.85			
IRB 6700-140/2.85 LID			
6	IRB 6700-300/2.70	$Ja_6 = \text{Load} \times L^2 + J_{0Z} \leq 225 \text{ kgm}^2$	
	IRB 6700-270/2.70 LID		
	IRB 6700-245/3.00		
	IRB 6700-220/3.00 LID		
	IRB 6700I-300/2.60		
	IRB 6700I-270/2.60 LID		
	IRB 6700I-245/2.90		
	IRB 6700I-210/2.90 LID		

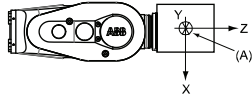

xx1400002028

Pos	Description
A	Center of gravity
Description	
J_{0X}, J_{0Y}, J_{0Z}	Max. moment of inertia around the X, Y and Z axes at center of gravity.

Continues on next page

1.5.3 Maximum load and moment of inertia for full and limited axis 5 (center line down) movement Continued

Limited axis 5, center line down

Axis	Robot type	Maximum moment of inertia
5	IRB 6700-235/2.65 IRB 6700-205/2.80 IRB 6700-175/3.05 IRB 6700-150/3.20	$Ja_5 = \text{Load} \times ((Z + 0.200)^2 + L^2) + \max(J_{0x}, J_{0y}) \leq 275 \text{ kgm}^2$
	IRB 6700-220/2.65 LID IRB 6700-200/2.80 LID IRB 6700-155/3.05 LID IRB 6700-145/3.20 LID	$Ja_5 = \text{Load} \times ((Z + 0.350)^2 + L^2) + \max(J_{0x}, J_{0y}) \leq 275 \text{ kgm}^2$
	IRB 6700-200/2.60 IRB 6700-155/2.85	$Ja_5 = \text{Load} \times ((Z + 0.200)^2 + L^2) + \max(J_{0x}, J_{0y}) \leq 215 \text{ kgm}^2$
	IRB 6700-175/2.60 LID IRB 6700-140/2.85 LID	$Ja_5 = \text{Load} \times ((Z + 0.350)^2 + L^2) + \max(J_{0x}, J_{0y}) \leq 215 \text{ kgm}^2$
	IRB 6700-300/2.70 IRB 6700-245/3.00 IRB 6700I-300/2.60 IRB 6700I-245/2.90	$Ja_5 = \text{Load} \times ((Z + 0.220)^2 + L^2) + \max(J_{0x}, J_{0y}) \leq 360 \text{ kgm}^2$
	IRB 6700-270/2.70 LID IRB 6700-220/3.00 LID IRB 6700I-270/2.60 LID IRB 6700I-210/2.90 LID	$Ja_5 = \text{Load} \times ((Z + 0.380)^2 + L^2) + \max(J_{0x}, J_{0y}) \leq 360 \text{ kgm}^2$
	6	IRB 6700-235/2.65 IRB 6700-220/2.65 LID IRB 6700-205/2.80 IRB 6700-200/2.80 LID IRB 6700-175/3.05 IRB 6700-155/3.05 LID IRB 6700-150/3.20 IRB 6700-145/3.20 LID
IRB 6700-200/2.60 IRB 6700-175/2.60 LID IRB 6700-155/2.85 IRB 6700-140/2.85 LID		$Ja_6 = \text{Load} \times L^2 + J_{0z} \leq 195 \text{ kgm}^2$
IRB 6700-300/2.70 IRB 6700-270/2.70 LID IRB 6700-245/3.00 IRB 6700-220/3.00 LID IRB 6700I-300/2.60 IRB 6700I-270/2.60 LID IRB 6700I-245/2.90 IRB 6700I-210/2.90 LID		$Ja_6 = \text{Load} \times L^2 + J_{0z} \leq 320 \text{ kgm}$

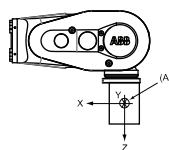

xx1400002029

Continues on next page

1 Description

1.5.3 Maximum load and moment of inertia for full and limited axis 5 (center line down) movement

Continued

Pos	Description
A	Center of gravity
	Description
J_{ox}, J_{oy}, J_{oz}	Max. moment of inertia around the X, Y and Z axes at center of gravity.

1.5.4 Wrist torque

**Note**

The wrist torque values are for reference only, and should not be used for calculating permitted load offset (position of center of gravity) within the load diagram, since those also are limited by main axes torques as well as dynamic loads. Furthermore, arm loads will influence the permitted load diagram. To find the absolute limits of the load diagram, use the RobotStudio add-in RobotLoad.

Torque

The table below shows the maximum permissible torque due to payload.

Robot type	Max wrist torque axis 4 and 5	Max wrist torque axis 6	Max torque valid at load
IRB 6700 - 235/2.65	1,324 Nm	650 Nm	225 kg
IRB 6700 - 205/2.80	1,263 Nm	625 Nm	192 kg
IRB 6700 - 200/2.60	981 Nm	429 Nm	175 kg
IRB 6700 - 175/3.05	1,179 Nm	589 Nm	154 kg
IRB 6700 - 155/2.85	927 Nm	410 Nm	144 kg
IRB 6700 - 150/3.20	1,135 Nm	570 Nm	137 kg
IRB 6700 - 300/2.70	1,825 Nm	865 Nm	280 kg
IRB 6700 - 245/3.00	1,693 Nm	815 Nm	214 kg
IRB 6700I - 300/2.60	1,825 Nm	865 Nm	280 kg
IRB 6700I - 245/2.90	1,645 Nm	796 Nm	194 kg

Torque for LeanID variants

The table below shows the maximum permissible torque due to payload.

Robot type	Max wrist torque axis 4 and 5	Max wrist torque axis 6	Max torque valid at load
IRB 6700 - 270/2.70 LID	1,825 Nm	865 Nm	280 kg
IRB 6700 - 220/3.00 LID	1,693 Nm	815 Nm	214 kg
IRB 6700 - 220/2.65 LID	1,324 Nm	650 Nm	225 kg
IRB 6700 - 200/2.80 LID	1,263 Nm	625 Nm	192 kg
IRB 6700 - 175/2.60 LID	981 Nm	429 Nm	175 kg
IRB 6700 - 155/3.05 LID	1,179 Nm	589 Nm	154 kg
IRB 6700 - 140/2.85 LID	927 Nm	410 Nm	144 kg
IRB 6700 - 145/3.20 LID	1,135 Nm	570 Nm	137 kg
IRB 6700I - 270/2.60 LID	1,825 Nm	865 Nm	280 kg
IRB 6700I - 210/2.90 LID	1,645 Nm	796 Nm	194 kg

1 Description

1.5.5 Maximum TCP acceleration

1.5.5 Maximum TCP acceleration

General

Higher values can be reached with lower loads than the nominal because of our dynamical motion control QuickMove2. For specific values in the unique customer cycle, or for robots not listed in the table below, we recommend then to use RobotStudio.



Note

Acceleration levels for emergency stop and controlled motion includes acceleration due to gravitational forces. Nominal load is defined with nominal mass and cog with max offset in Z and L (see the load diagram).

1.6 Fitting equipment to the robot

General

Extra loads can be fitted on the upper arm housing, the lower arm, and on the frame. Definitions of distances and masses are shown in the following figures. The robot is supplied with holes for fitting extra equipment (see figure in [Holes for fitting extra equipment on page 70](#)). Maximum allowed arm load depends on center of gravity of arm load and robot payload.



Note

All equipment and cables used on the robot, must be designed and fitted not to damage the robot and/or its parts.

Frame (hip load)

Extra load can be fitted on the frame.

	Description
Permitted extra load on frame	$J_H = 100 \text{ kgm}^2$
Recommended position (see the following figure)	$J_H = J_{H0} + M4 \times R^2$ where: <ul style="list-style-type: none"> • J_{H0} is the moment of inertia of the equipment • R is the radius (m) from the center of axis 1 • $M4$ is the total mass (kg) of the equipment including bracket and harness ($\leq 250 \text{ kg}$)

Continues on next page

1 Description

1.6 Fitting equipment to the robot

Continued

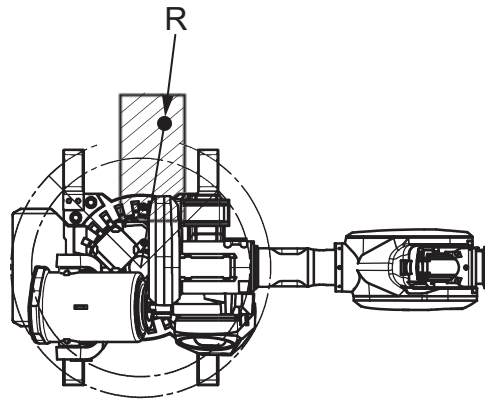
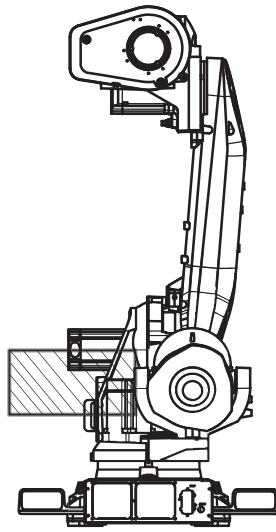

xx130000262

Upper arm

Allowed extra load on the upper arm housing, in addition to the maximum handling weight, is $M1 \leq 50$ kg with a distance (a) ≤ 500 mm from the center of gravity in the axis-3 extension.

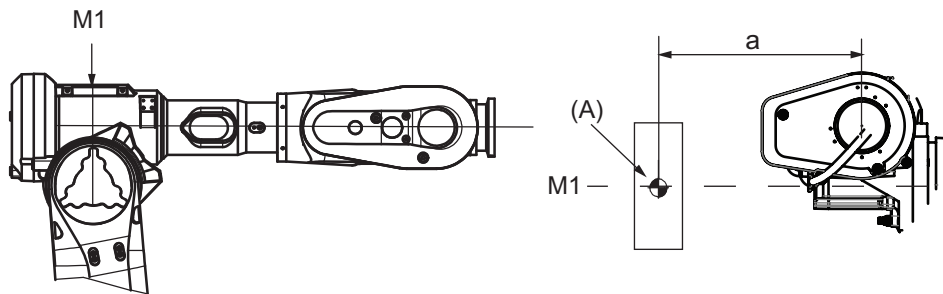

xx1400002019

A	Mass center
---	-------------

Continues on next page

1 Description

1.6 Fitting equipment to the robot

Continued

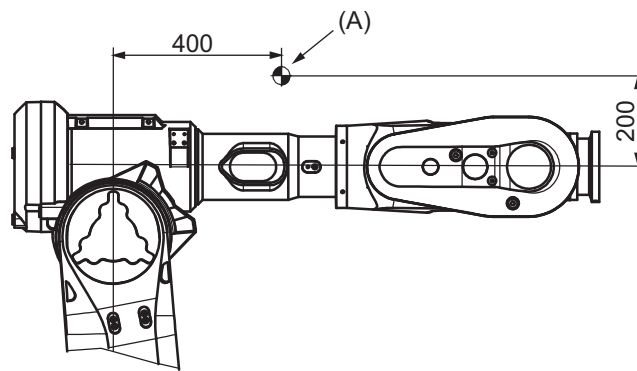

xx130000866

A	Center of gravity 50 kg
---	-------------------------

Continues on next page

1 Description

1.6 Fitting equipment to the robot

Continued

Holes for fitting extra equipment

Position of attachment holes - drawing 1

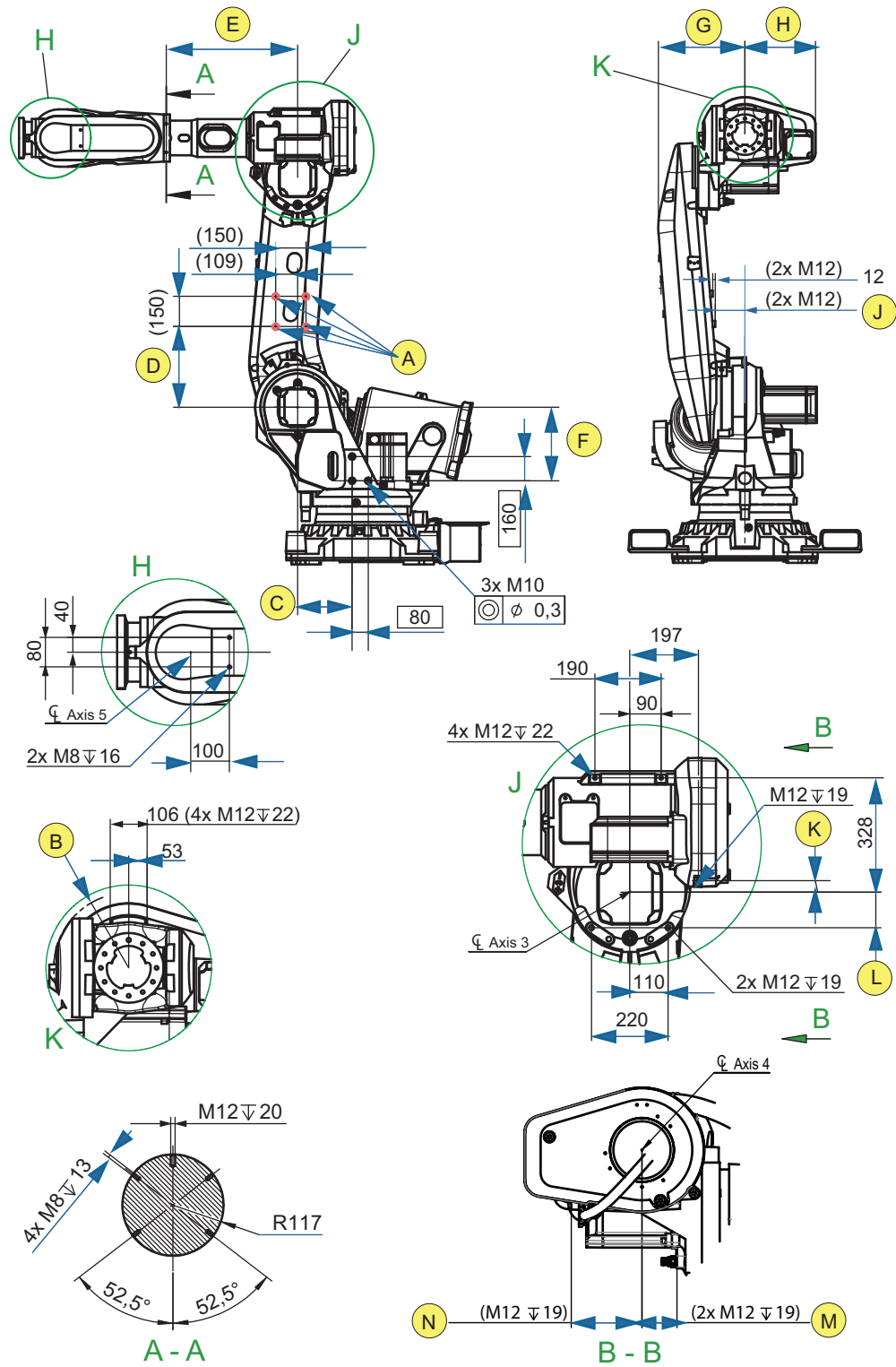

A	Allowed position for attachment holes, M12 through. Be careful not to touch the cables when drilling.
---	---

Continues on next page

1 Description

1.6 Fitting equipment to the robot

Continued

Variant	B ⁱ	C	D	E	F	G	H	J	K	L	M	N
IRB 6700 - 235/2.65	R=216	270	400	652.5	365	437	349	147	33	102	104	210
IRB 6700 - 220/2.65 LID	R=216	270	400	652.5	365	437	349	147	33	102	104	210
IRB 6700 - 205/2.80	R=216	270	500	652.5	365	437	349	147	33	102	104	210
IRB 6700 - 200/2.80 LID	R=216	270	500	652.5	365	437	349	147	33	102	104	210
IRB 6700 - 175/3.05	R=216	270	400	652.5	365	437	349	147	33	102	104	210
IRB 6700 - 155/3.05 LID	R=216	270	400	652.5	365	437	349	147	33	102	104	210
IRB 6700 - 150/3.20	R=216	270	500	652.5	365	437	349	147	33	102	104	210
IRB 6700 - 145/3.20 LID	R=216	270	500	652.5	365	437	349	147	33	102	104	210
IRB 6700 - 200/2.60	R=204.5	270	400	650.5	365	437	315	143	43	102	95	210
IRB 6700 - 175/2.60 LID	R=204.5	270	400	650.5	365	437	315	143	43	102	95	210
IRB 6700 - 155/2.85	R=204.5	270	400	650.5	365	437	315	143	43	102	95	210
IRB 6700 - 140/2.85 LID	R=204.5	270	400	650.5	365	437	315	143	43	102	95	210
IRB 6700 - 300/2.70	R=230	310	450	652.5	376	467	405	152	12	117	98.5	215.5
IRB 6700 - 270/2.70 LID	R=230	310	450	652.5	376	467	405	152	12	117	98.5	215.5
IRB 6700 - 245/3.00	R=230	310	450	652.5	376	467	405	152	12	117	98.5	215.5
IRB 6700 - 220/3.00 LID	R=230	310	450	652.5	376	467	405	152	12	117	98.5	215.5
IRB 6700I - 300/2.60	R=230	310	450	652.5	425.6	467	405	152	12	117	98.5	215.5
IRB 6700I - 270/2.60 LID	R=230	310	450	652.5	425.6	467	405	152	12	117	98.5	215.5
IRB 6700I - 245/2.90	R=230	310	450	652.5	425.6	467	405	152	12	117	98.5	215.5
IRB 6700I - 210/2.90 LID	R=230	310	450	652.5	425.6	467	405	152	12	117	98.5	215.5

ⁱ Smallest circumscribed radius axis-4.

Continues on next page

1 Description

1.6 Fitting equipment to the robot

Continued

Position of attachment holes - drawing 2

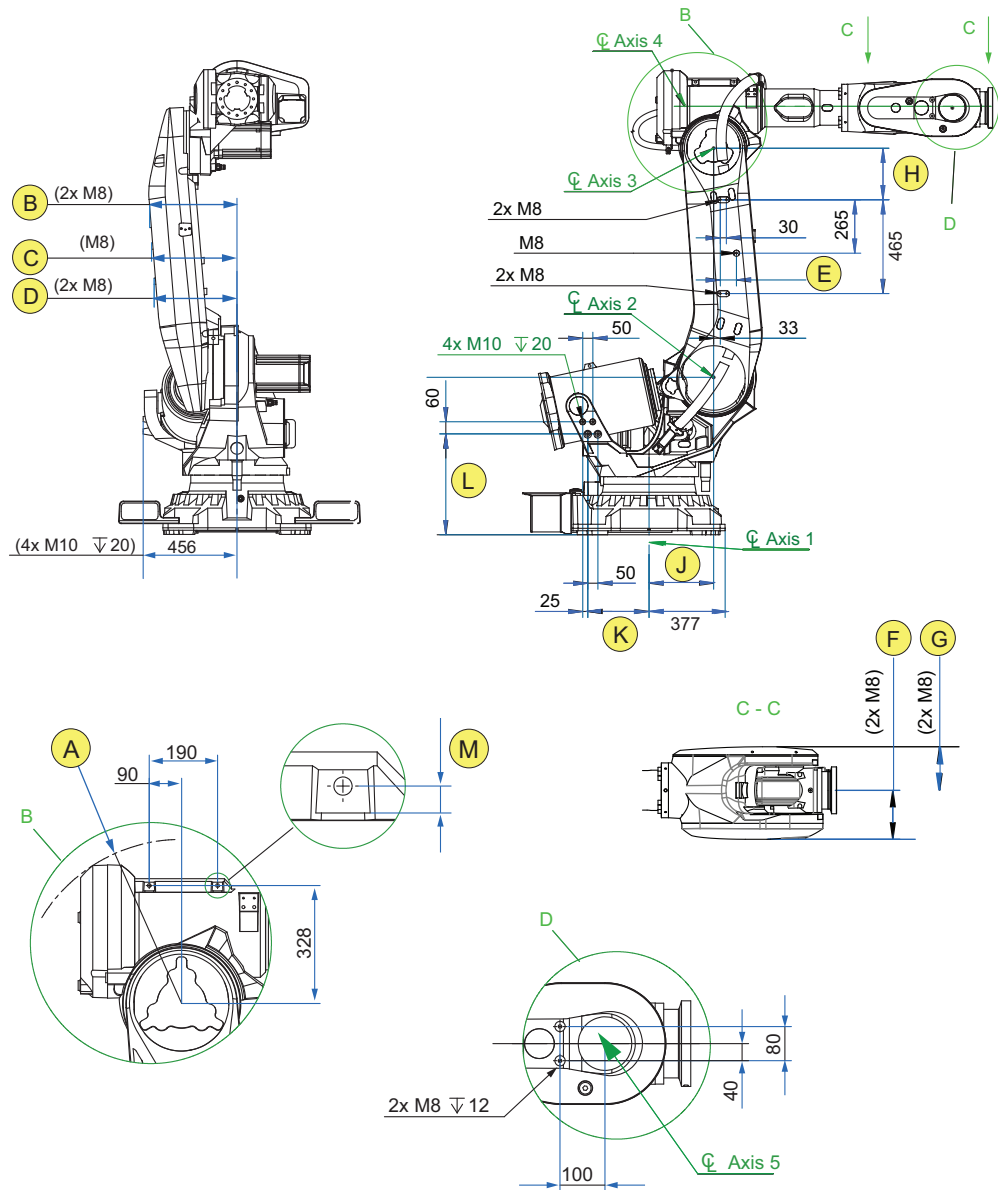

xx1300000264

Variant	A ⁱ	B	C	D	E	F	G	H	J	K	L	M
IRB 6700 - 235/2.65	R=456	433	418	403	80	208.5	186	255	320	303.5	500	13.8
IRB 6700 - 220/2.65 LID	R=477	433	418	403	80	208.5	186	255	320	303.5	500	13.8
IRB 6700 - 205/2.80	R=456	438	423	408	80	208.5	186	255	320	303.5	500	13.8
IRB 6700 - 200/2.80 LID	R=477	438	423	408	80	208.5	186	255	320	303.5	500	13.8
IRB 6700 - 155/3.05 LID	R=465	433	418	403	80	208.5	186	255	320	303.5	500	13.8
IRB 6700 - 175/3.05	R=477	433	418	403	80	208.5	186	255	320	303.5	500	13.8
IRB 6700 - 150/3.20	R=456	438	423	408	80	208.5	186	255	320	303.5	500	13.8
IRB 6700 - 145/3.20 LID	R=477	438	423	408	80	208.5	186	255	320	303.5	500	13.8
IRB 6700 - 200/2.60	R=440	425	410	395	113	197	193	255	320	303.5	500	13.8

Continues on next page

1 Description

1.6 Fitting equipment to the robot

Continued

Variant	A ⁱ	B	C	D	E	F	G	H	J	K	L	M
IRB 6700 - 175/2.60 LID	R=472	425	410	395	113	197	193	255	320	303.5	500	13.8
IRB 6700 - 155/2.85	R=440	425	410	395	113	197	193	255	320	303.5	500	13.8
IRB 6700 - 140/2.85 LID	R=472	425	410	395	113	197	193	255	320	303.5	500	13.8
IRB 6700 - 300/2.70	R=468	453	438	423	80	222.5	187	265	350	273.5	523.5	15
IRB 6700 - 270/2.70 LID	R=481	453	438	423	80	222.5	187	265	350	273.5	523.5	15
IRB 6700 - 245/3.00	R=468	453	438	423	80	222.5	187	265	350	273.5	523.5	15
IRB 6700 - 220/3.00 LID	R=481	453	438	423	80	222.5	187	265	350	273.5	523.5	15
IRB 6700I - 300/2.60	R=468	453	438	423	80	222.5	187	265	350	273.5	523.5	15
IRB 6700I - 270/2.60 LID	R=481	453	438	423	80	222.5	187	265	350	273.5	523.5	15
IRB 6700I - 245/2.90	R=468	453	438	423	80	222.5	187	265	350	273.5	523.5	15
IRB 6700I - 210/2.90 LID	R=481	453	438	423	80	222.5	187	265	350	273.5	523.5	15

ⁱ Smallest circumscribed radius axis-3.

Extra cover

There is an extra cover for LID variants (upper arm cover). So that value A for LID variants is different.

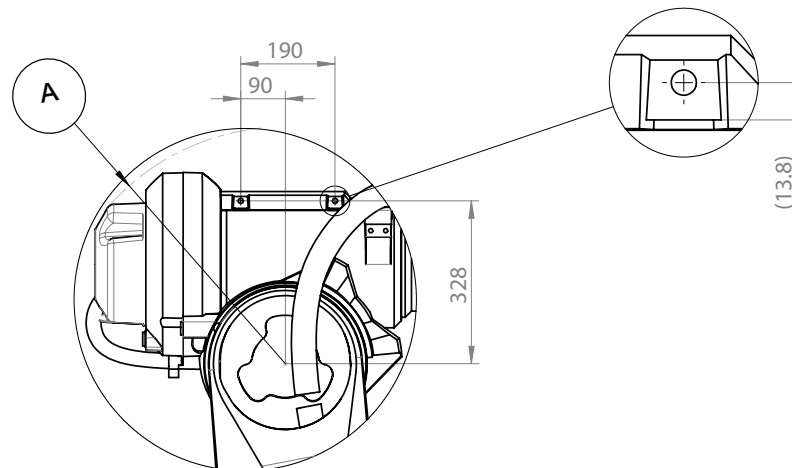

xx2100002054

Continues on next page

1 Description

1.6 Fitting equipment to the robot

Continued

Tool flange, standard

Below is the standard tool flange. The guide pin hole is, in calibration position, pointing upwards in Z-direction.

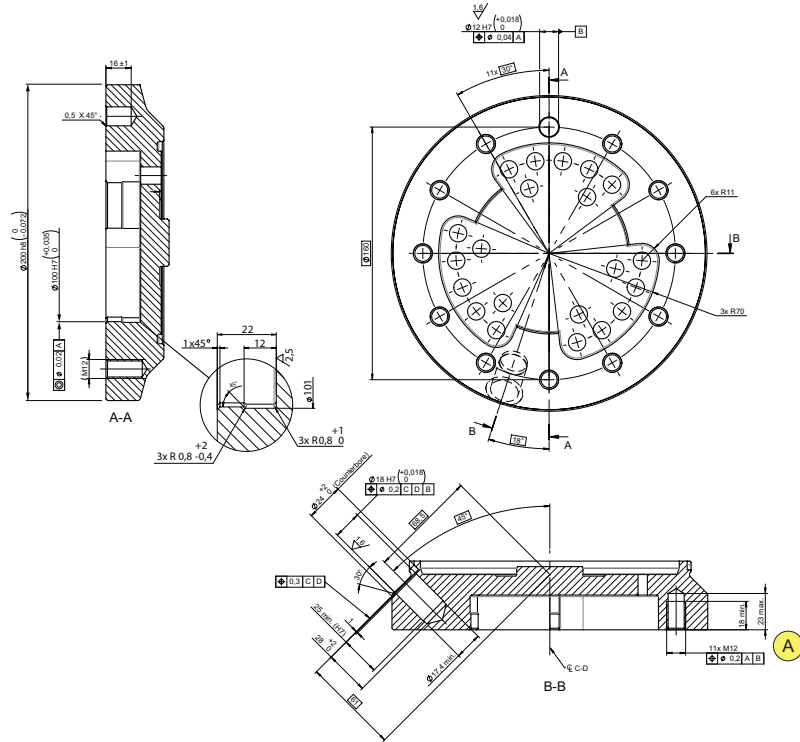

xx1300000280

A	Thread length: 18 mm.
---	-----------------------

The turning disc for robot variants IRB 6700 - 200/2.60 and IRB 6700 - 155/2.85 was redesigned when Axis Calibration was introduced for IRB 6700. Prior to Axis Calibration the holes on the disc were through. On the current turning disc the holes are not through.

Continues on next page

Tool flange, LID Variants

Below is the tool flange for LID variants. The guide pin hole is, in calibration position, pointing upwards in Z-direction.

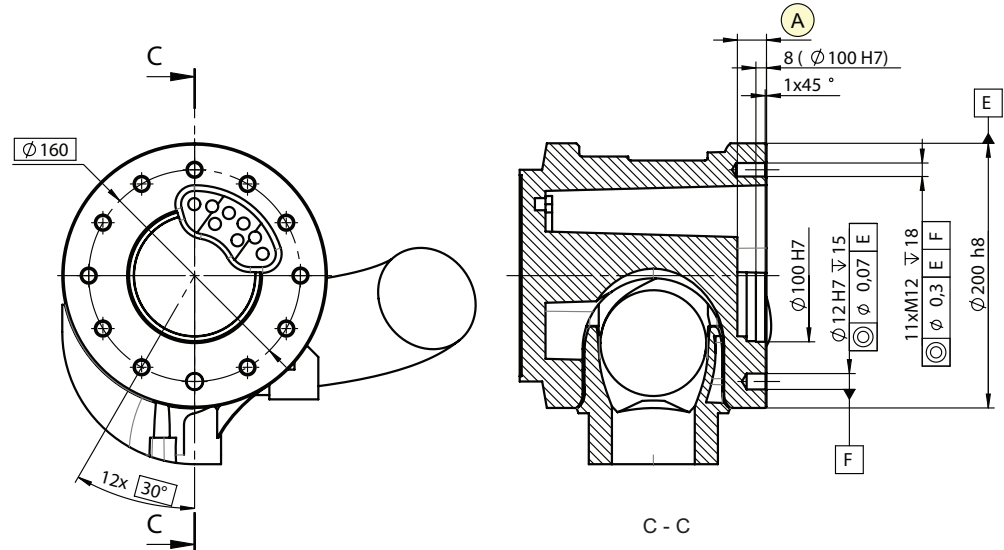

xx1300000290

A	Thread length: 18 mm.
---	-----------------------

Fastener quality

When fitting tools on the tool flange, only use screws with quality 12.9. For other equipment use suitable screws and tightening torque for your application.

1 Description

1.7 Maintenance and troubleshooting

1.7 Maintenance and troubleshooting

General

The robot requires only minimum maintenance during operation. It has been designed to make it as easy to service as possible:

- Maintenance-free AC motors are used.
- Oil is used for the gearboxes.
- The cabling is routed for longevity, and in the unlikely event of a failure, its modular design makes it easy to change.

Maintenance

The maintenance intervals depend on the use of the robot. The required maintenance activities also depend on the selected options. For detailed information on maintenance procedures, see the maintenance section in product manuals.

1.8 Robot motion

1.8.1 Robot motion

Type of motion

Axis	Type of motion	Range of movement - IRB 6700	Range of movement - IRB 6700Inv	Note
Axis 1	Rotation motion	$\pm 170^\circ$ or $\pm 220^\circ$ (option)	$\pm 170^\circ$	
Axis 2	Arm motion	$-65^\circ/+85^\circ$ ⁱ	$\pm 65^\circ$ ⁱⁱ	
Axis 3	Arm motion	$-180^\circ/+70^\circ$	-180° ⁱⁱ / $+70^\circ$ ⁱⁱ	
Axis 4	Wrist motion	$\pm 300^\circ$	$\pm 300^\circ$	
Axis 5	Bend motion	$\pm 130^\circ$ ⁱⁱⁱ	$\pm 130^\circ$ ⁱⁱⁱ	
Axis 6	Turn motion	$\pm 360^\circ$ ^{iv}	$\pm 360^\circ$ ^{iv}	<p>Maximum value.</p> <p>The default working range for axis 6 can be extended by changing parameter values in the software.</p> <p>Option 3111-1 <i>Independent axis</i> can be used for resetting the revolution counter after the axis has been rotated (no need for "rewinding" the axis).</p>
		± 93.7 revolutions	± 93.7 revolutions	

ⁱ Working range for variants IRB 6700 - 300/2.70 and - 245/3.00:

+85° to -65° when axis 3 is within +70° to -45°

+85° to -58° when axis 3 is within +70° to -180°

ⁱⁱ Working ranges of axis 2 and axis 3 are limited in some areas to avoid collision with balancing.

ⁱⁱⁱ Working range +120° to -120° for robots with LID Variants.

^{iv} Working range +220° to -220° for robots with LID Variants.

Continues on next page

1 Description

1.8.1 Robot motion

Continued

Working range axis 2 and axis 3 for IRB 6700-300/2.70, IRB 6700-270/2.70 LID, IRB 6700-245/3.00 and IRB 6700-220/3.00 LID

Limited in some areas to avoid collision with balancing.

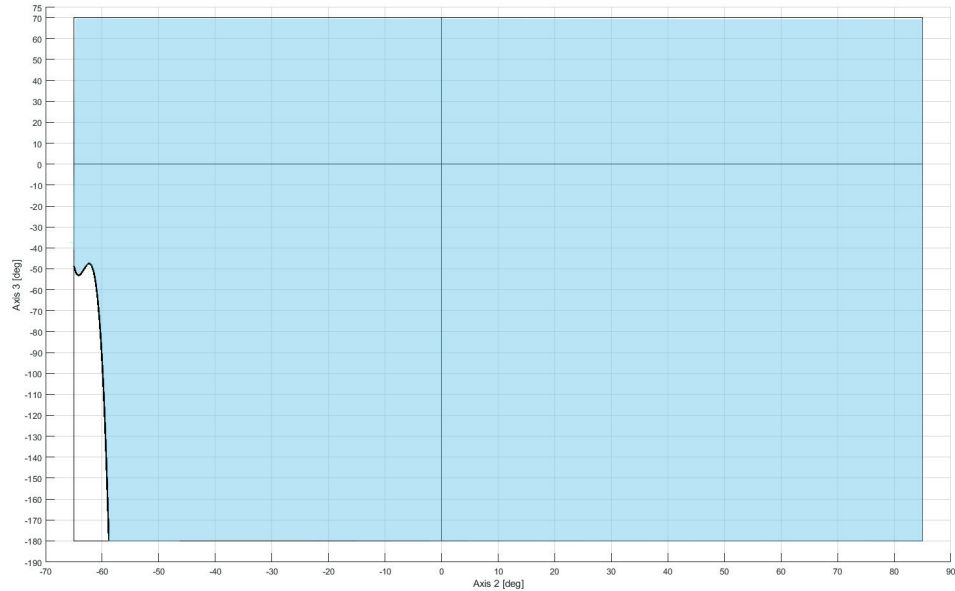

xx170000509

Working range axis 2 and axis 3 for IRB 6700I-300/2.60, IRB 6700I-270/2.60 LID, IRB 6700I-245/2.90 and IRB 6700I-210/2.90 LID

Limited in some areas to avoid collision with balancing.

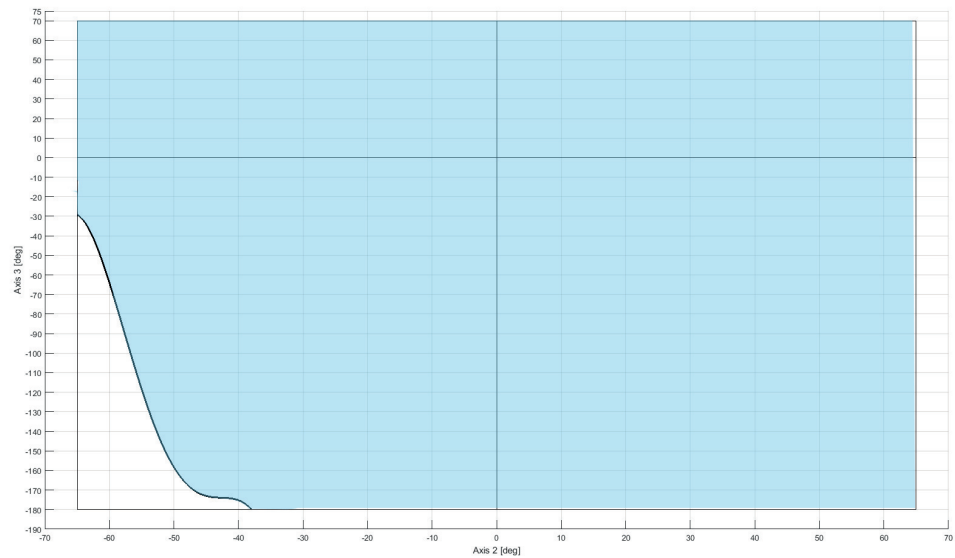

xx170000510

Continues on next page

Working range axis 5 and axis 6 for LID variants

Allowed working area for axis 6 related to axis 5 position is shown in the figure below.

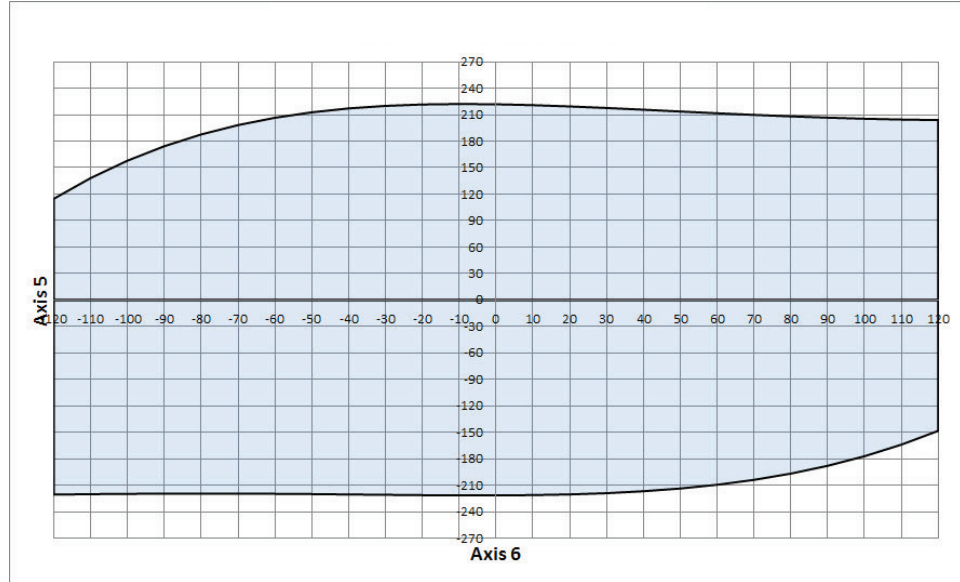

xx1300001587

1 Description

1.8.1 Robot motion

Continued

Working range

Robot type	Handling capacity (kg)	Reach (m)
IRB 6700	235	2.65
IRB 6700 (LID variant)	220	2.65

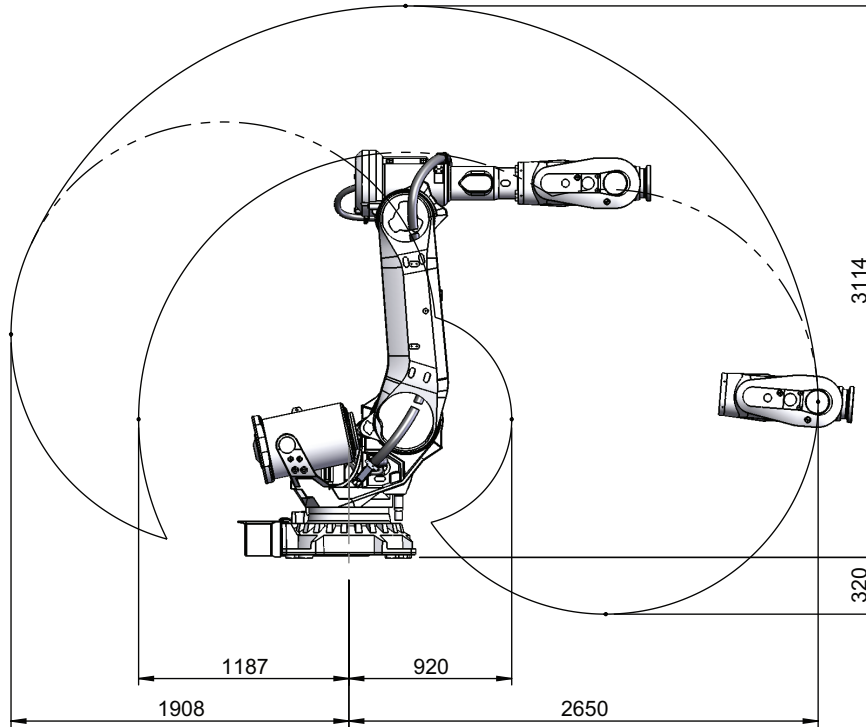

xx130000281

Continues on next page

1 Description

1.8.1 Robot motion *Continued*

Robot type	Handling capacity (kg)	Reach (m)
IRB 6700	205	2.80
IRB 6700 (LID variant)	200	2.80

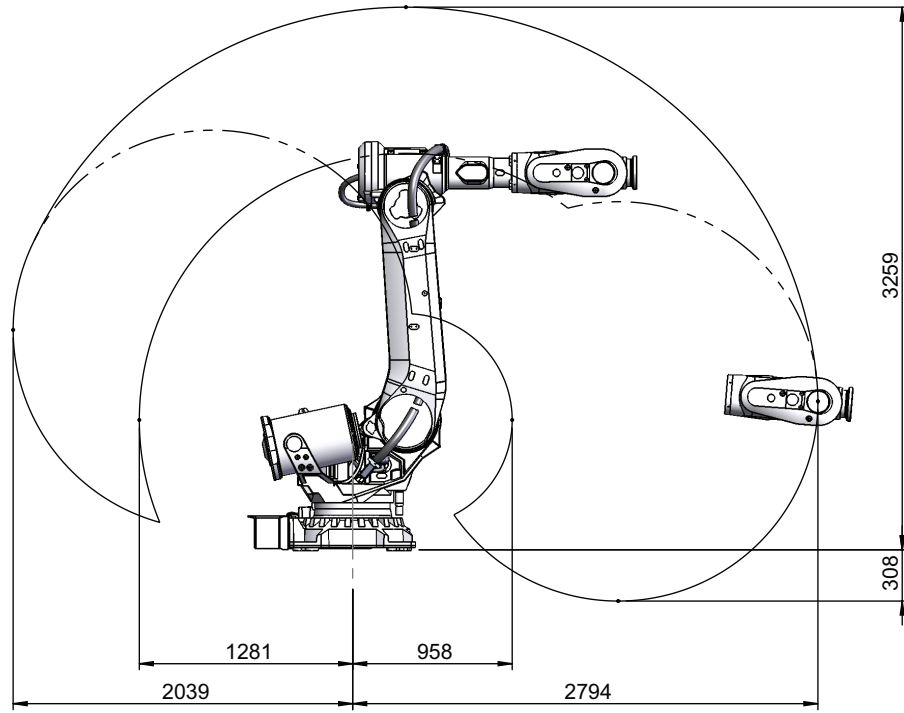

Continues on next page

1 Description

1.8.1 Robot motion

Continued

Robot type	Handling capacity (kg)	Reach (m)
IRB 6700	200	2.60
IRB 6700 (LID variant)	175	2.60

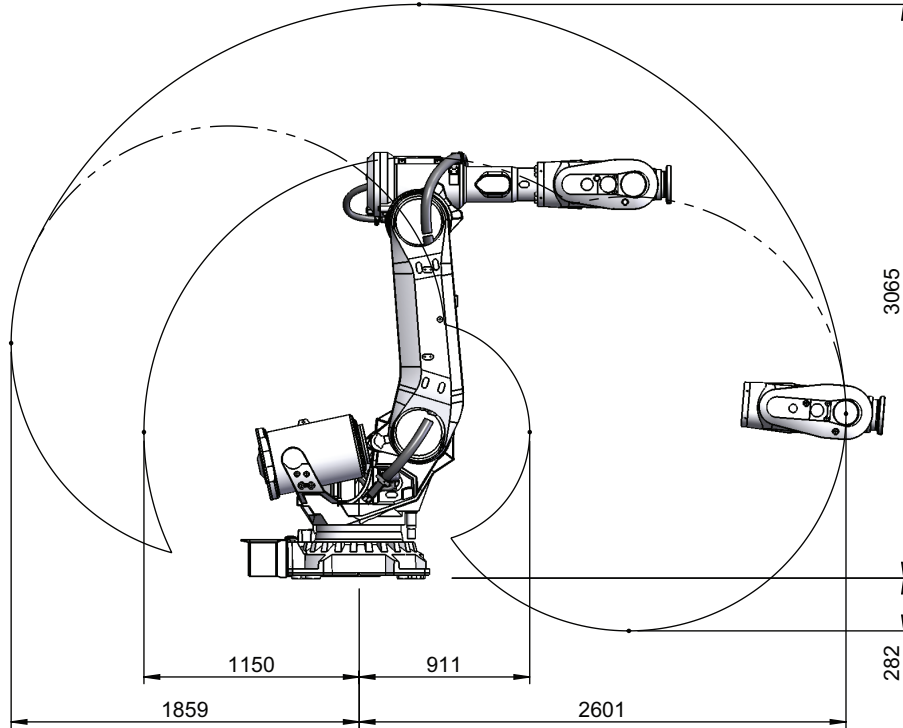

xx1300000341

Continues on next page

1 Description

1.8.1 Robot motion *Continued*

Robot type	Handling capacity (kg)	Reach (m)
IRB 6700	175	3.05
IRB 6700 (LID variant)	155	3.05

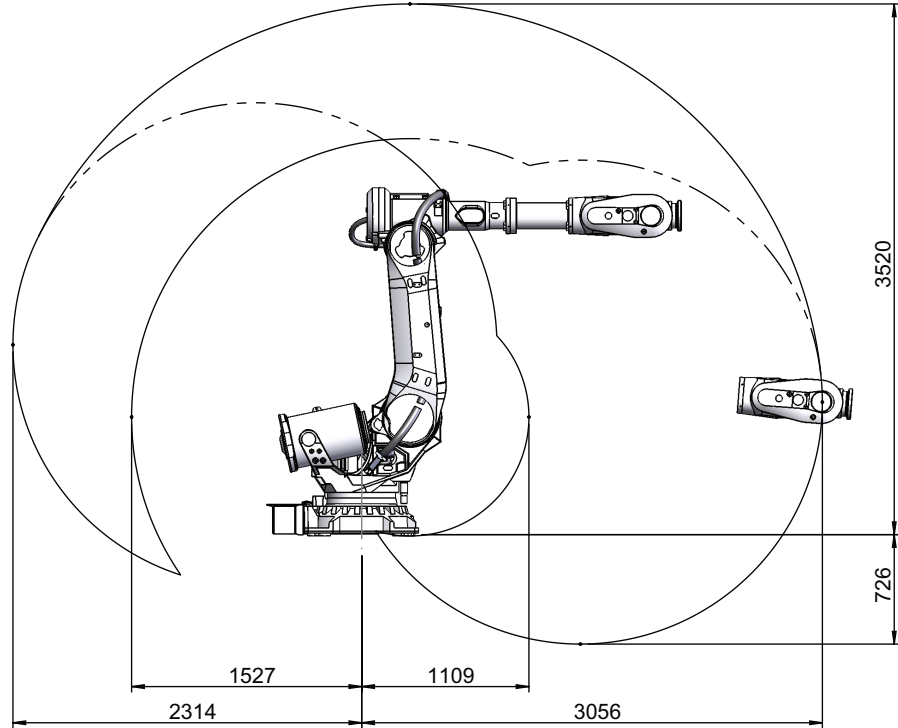

xx130000283

Continues on next page

1 Description

1.8.1 Robot motion

Continued

Robot type	Handling capacity (kg)	Reach (m)
IRB 6700	155	2.85
IRB 6700 (LID variant)	140	2.85

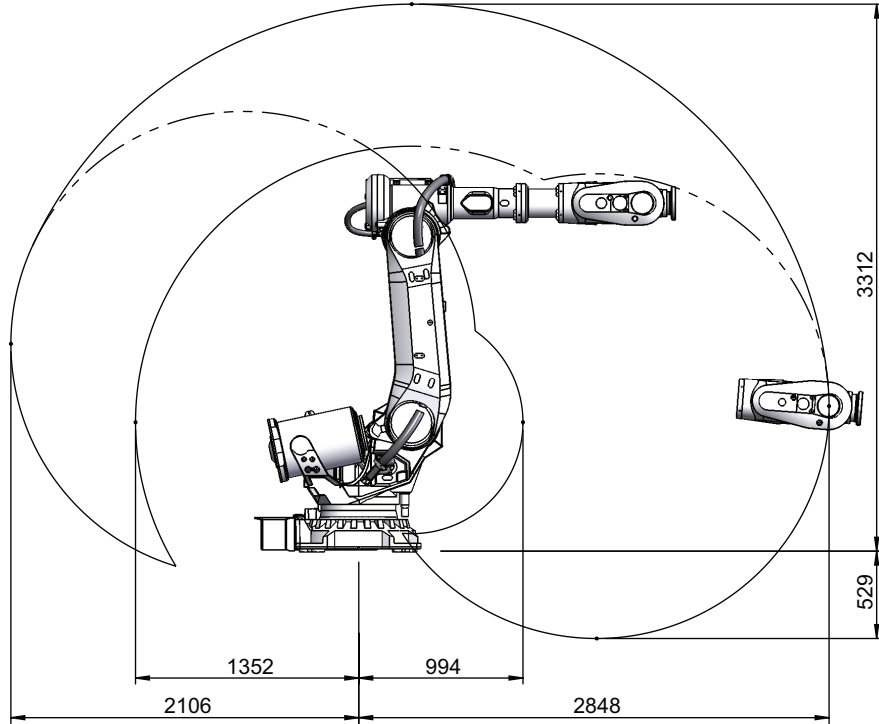

Continues on next page

1 Description

1.8.1 Robot motion *Continued*

Robot type	Handling capacity (kg)	Reach (m)
IRB 6700	150	3.20
IRB 6700 (LID variant)	145	3.20

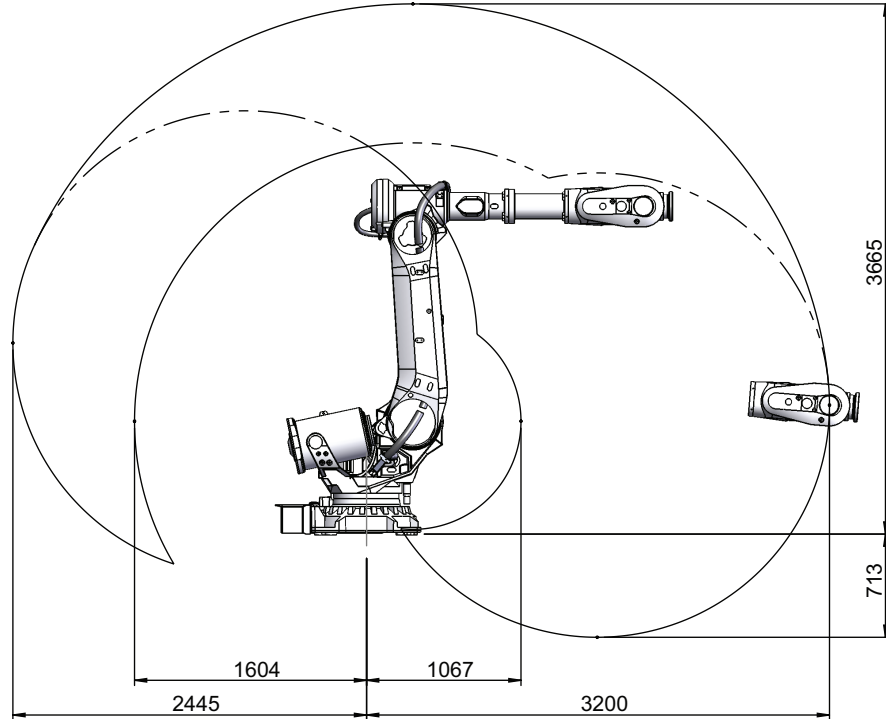

Continues on next page

1 Description

1.8.1 Robot motion

Continued

Robot type	Handling capacity (kg)	Reach (m)
IRB 6700	300	2.70
IRB 6700 (LID variant)	270	2.70

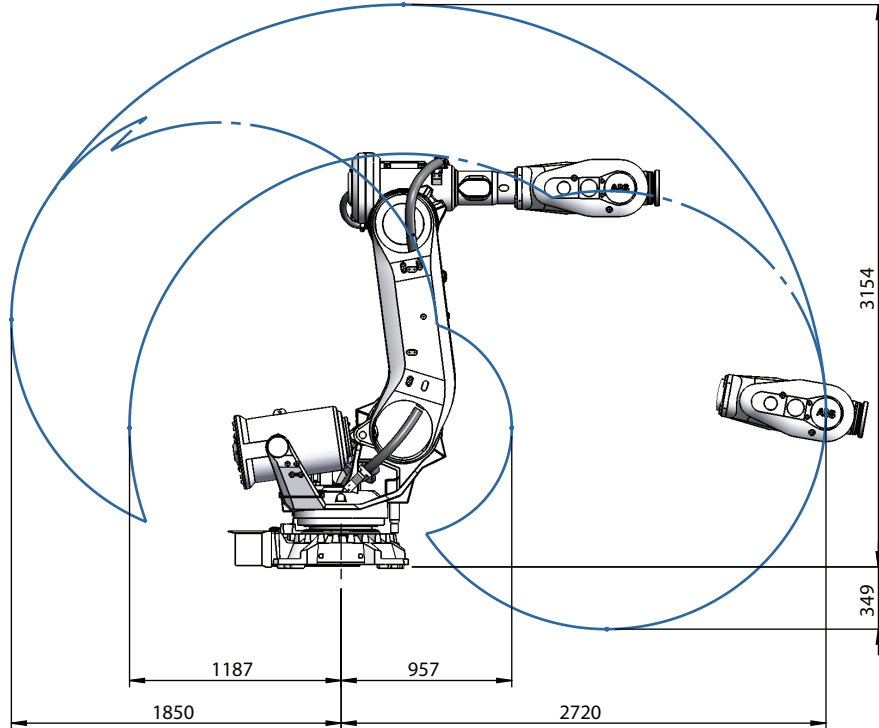

Continues on next page

1 Description

1.8.1 Robot motion *Continued*

Robot type	Handling capacity (kg)	Reach (m)
IRB 6700	245	3.00
IRB 6700 (LID variant)	220	3.00

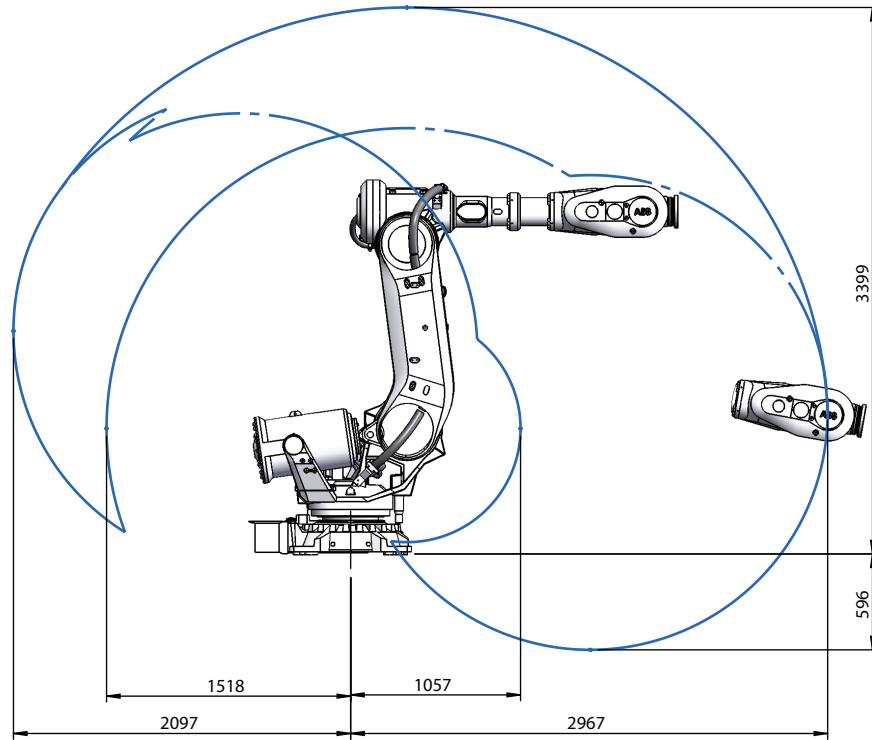

xx1400001138

Continues on next page

1 Description

1.8.1 Robot motion

Continued

Robot type	Handling capacity (kg)	Reach (m)
IRB 6700Inv	300	2.60
IRB 6700Inv (LID variant)	270	2.60

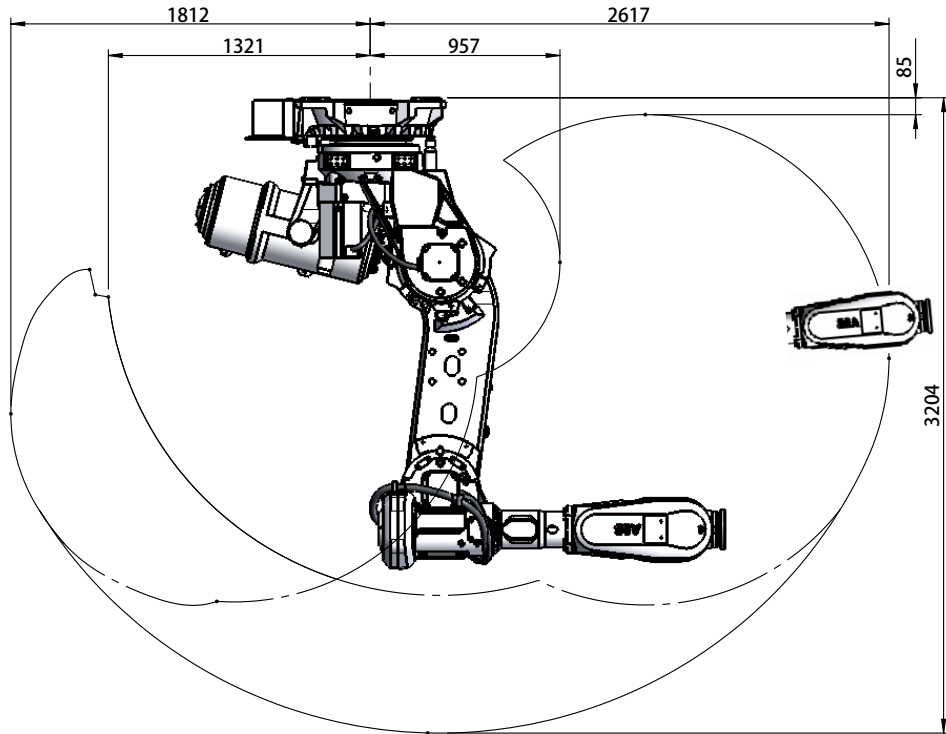

xx170000557

Continues on next page

1 Description

1.8.1 Robot motion *Continued*

Robot type	Handling capacity (kg)	Reach (m)
IRB 6700Inv	245	2.90
IRB 6700Inv (LID variant)	210	2.90

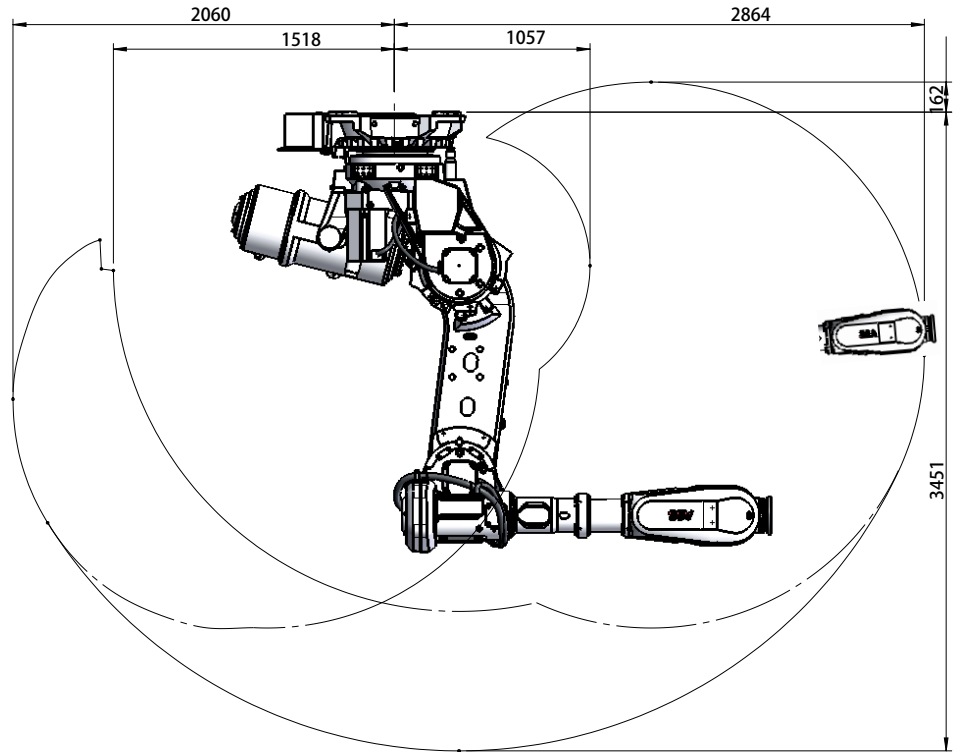

xx170000558

1 Description

1.8.2 Performance according to ISO 9283

1.8.2 Performance according to ISO 9283

General

At rated maximum load, maximum offset and 1.6 m/s velocity on the inclined ISO test plane, with all six axes in motion. Values in the table below are the average result of measurements on a small number of robots. The result may differ depending on where in the working range the robot is positioning, velocity, arm configuration, from which direction the position is approached, the load direction of the arm system. Backlashes in gearboxes also affect the result.

The figures for AP, RP, AT and RT are measured according to figure below.

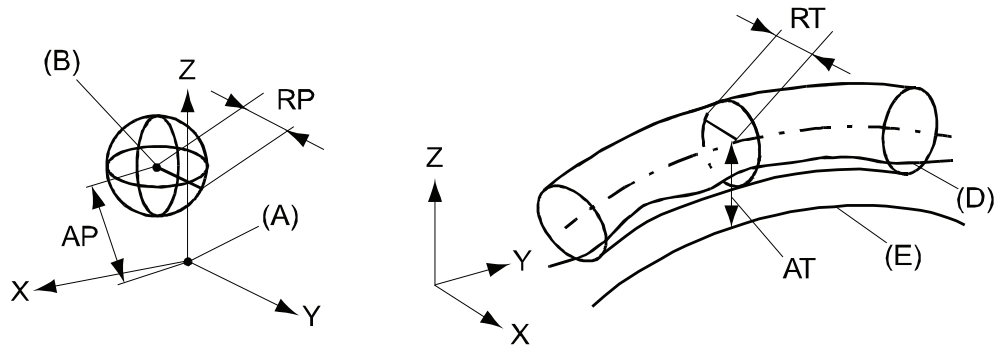

xx080000424

Pos	Description	Pos	Description
A	Programmed position	E	Programmed path
B	Mean position at program execution	D	Actual path at program execution
AP	Mean distance from programmed position	AT	Max deviation from E to average path
RP	Tolerance of position B at repeated positioning	RT	Tolerance of the path at repeated program execution

IRB 6700	235/2.65 and 220/2.65 LID	205/2.80 and 200/2.80 LID	175/3.05 and 155/3.05 LID	150/3.20 and 145/3.20 LID
Pose accuracy, AP ⁱ (mm)	0.03	0.06	0.04	0.05
Pose repeatability, RP (mm)	0.05	0.05	0.05	0.06
Pose stabilization time, PSt (s) within 0.4 mm of the position	0.16	0.17	0.28	0.34
Path accuracy, AT (mm)	1.7	1.5	1.9	1.6
Path repeatability, RT (mm)	0.08	0.08	0.12	0.14

ⁱ AP according to the ISO test above, is the difference between the taught position (position manually modified in the cell) and the average position obtained during program execution.

Continues on next page

IRB 6700	200/2.60 and 175/2.60 LID	155/2.85 and 140/2.85 LID	300/2.70 and 270/2.70 LID	245/3.00 and 220/3.00 LID
Pose accuracy, AP ⁱ (mm)	0.03	0.03	0.07	0.03
Pose repeatability, RP (mm)	0.05	0.08	0.06	0.05
Pose stabilization time, PSt (s) within 0.4 mm of the position	0.21	0.19	0.11	0.14
Path accuracy, AT (mm)	1.7	1.5	1.4	1.6
Path repeatability, RT (mm)	0.11	0.09	0.07	0.12

ⁱ AP according to the ISO test above, is the difference between the taught position (position manually modified in the cell) and the average position obtained during program execution.

IRB 6700Inv	300/2.60 and 270/2.60 LID	245/2.90 and 210/2.90 LID
Pose accuracy, AP ⁱ (mm)	0.06	0.06
Pose repeatability, RP (mm)	0.05	0.06
Pose stabilization time, PSt (s) within 0.4 mm of the position	0.26	0.28
Path accuracy, AT (mm)	1.6	1.6
Path repeatability, RT (mm)	0.1	0.22

ⁱ AP according to the ISO test above, is the difference between the taught position (position manually modified in the cell) and the average position obtained during program execution.

1 Description

1.8.3 Velocity

1.8.3 Velocity

Maximum axis speed

Robot type	Axis 1	Axis 2	Axis 3	Axis 4	Axis 5	Axis 6
IRB 6700-235/2.65	100 °/s	90 °/s	90 °/s	170 °/s	120 °/s	190 °/s
IRB 6700-220/2.65 LID	100 °/s	90 °/s	90 °/s	170 °/s	120 °/s	190 °/s
IRB 6700-205/2.80	100 °/s	90 °/s	90 °/s	170 °/s	120 °/s	190 °/s
IRB 6700-200/2.80 LID	100 °/s	90 °/s	90 °/s	170 °/s	120 °/s	190 °/s
IRB 6700-200/2.60	110 °/s	110 °/s	110 °/s	190 °/s	150 °/s	210 °/s
IRB 6700-175/2.60 LID	110 °/s	110 °/s	110 °/s	190 °/s	150 °/s	210 °/s
IRB 6700-175/3.05	100 °/s	90 °/s	90 °/s	170 °/s	120 °/s	190 °/s
IRB 6700-155/3.05 LID	100 °/s	90 °/s	90 °/s	170 °/s	120 °/s	190 °/s
IRB 6700-155/2.85	110 °/s	110 °/s	110 °/s	190 °/s	150 °/s	210 °/s
IRB 6700-140/2.85 LID	110 °/s	110 °/s	110 °/s	190 °/s	150 °/s	210 °/s
IRB 6700-150/3.20	100 °/s	90 °/s	90 °/s	170 °/s	120 °/s	190 °/s
IRB 6700-145/3.20 LID	100 °/s	90 °/s	90 °/s	170 °/s	120 °/s	190 °/s
IRB 6700-300/2.70	100 °/s	88 °/s	90 °/s	140 °/s	110 °/s	180 °/s
IRB 6700-270/2.70 LID	100 °/s	88 °/s	90 °/s	140 °/s	110 °/s	180 °/s
IRB 6700-245/3.00	100 °/s	88 °/s	90 °/s	140 °/s	110 °/s	180 °/s
IRB 6700-220/3.00 LID	100 °/s	88 °/s	90 °/s	140 °/s	110 °/s	180 °/s
IRB 6700I-300/2.60	100 °/s	88 °/s	90 °/s	140 °/s	110 °/s	180 °/s
IRB 6700I-270/2.60 LID	100 °/s	88 °/s	90 °/s	140 °/s	110 °/s	180 °/s
IRB 6700I-245/2.90	100 °/s	88 °/s	90 °/s	140 °/s	110 °/s	180 °/s
IRB 6700-210/2.90 LID	100 °/s	88 °/s	90 °/s	140 °/s	110 °/s	180 °/s

There is a supervision function to prevent overheating in applications with intensive and frequent movements (high duty cycle).

1.8.4 Robot stopping distances and times

Introduction

The stopping distances and times for category 0 and category 1 stops, as required by EN ISO 10218-1 Annex B, are listed in *Product specification - Robot stopping distances according to ISO 10218-1 (3HAC048645-001)*.

This page is intentionally left blank

2 DressPack

2.1 Introduction

2.1.1 Included options

DressPack

Includes options for upper arm, lower arm and floor pos B, C and D, see the following figure. These are described separately below but are designed as a complete package for various applications.

The DressPack for the floor contains customer signals.

The DressPack for upper and lower arm contains process cable packages including signals, for customer use.

Necessary supports and brackets are also included.

The routing of the process cable package on the robot is available in different configurations.

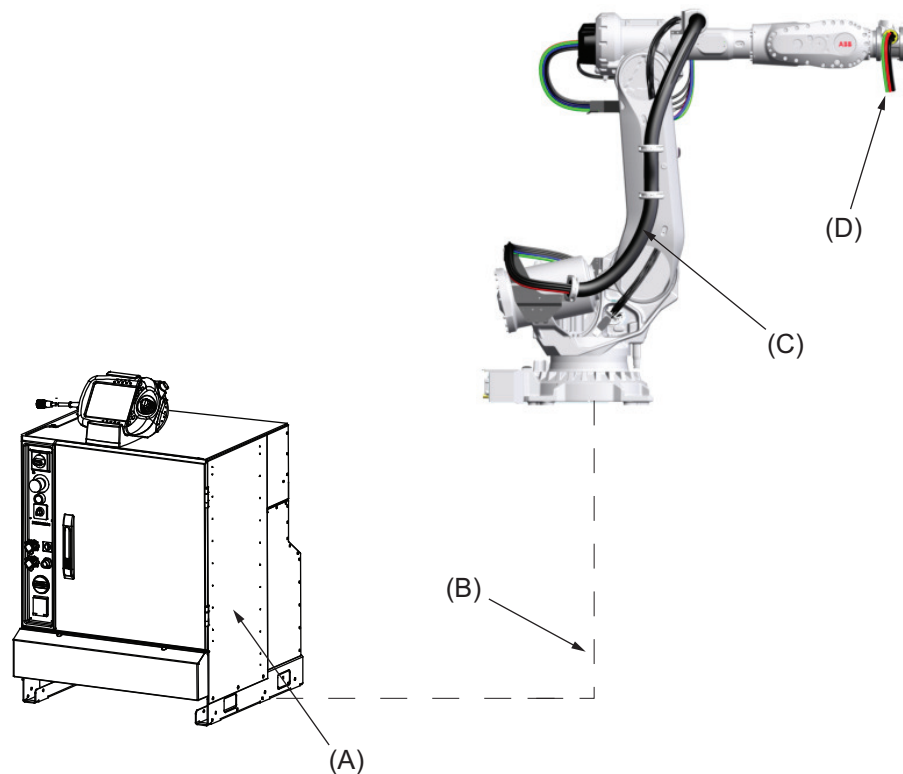

xx1300001588

Pos	Description
A	Robot controller, (including 7th axis drive for servo gun)
B	DressPack, floor
C	DressPack, lower arm
D	DressPack, upper arm

Continues on next page

2 DressPack

2.1.2 Product range

Continued

2.1.2 Product range

DressPack solutions for different users needs

The different robot types can be equipped with the well integrated cable and hose packages in the DressPack options. The DressPack is designed in close conjunction with the development of the manipulator and is therefore well synchronized with the robot.

As there is a big span between different users need of flexibility, depending of the complexity of the operation/wrist movements, there are two major levels of dress pack solutions available, see Figure below.

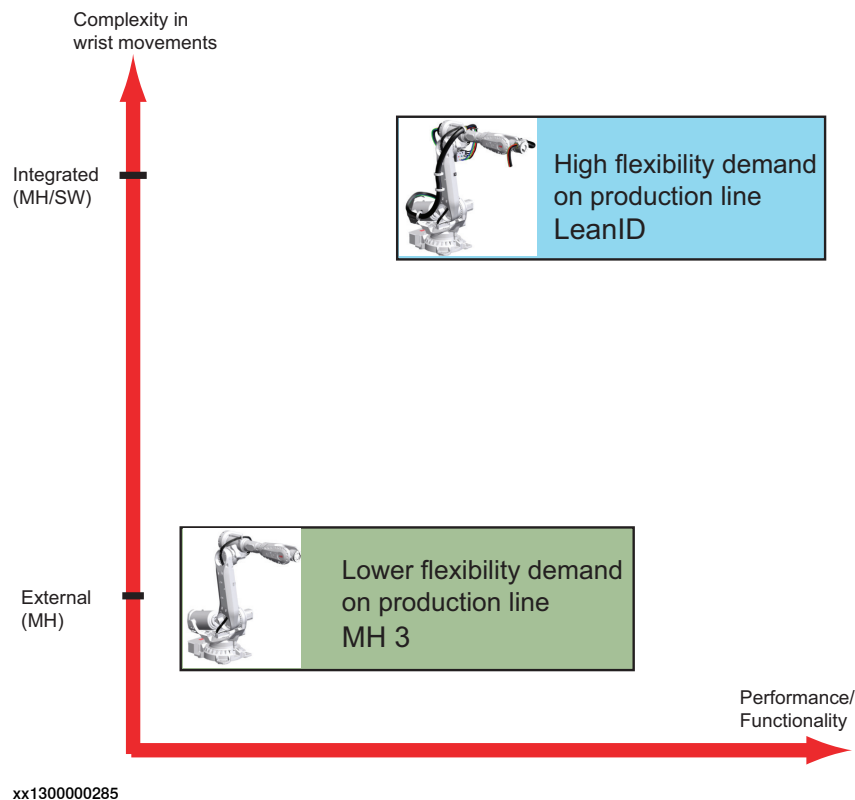

Integrated

This type of dress pack is intended for a production where there are many complex wrist movements and the need for flexibility in changing products is high.

Available options are 3325-11/12/13 and 3326-31/32/33 for material handling, the LeanID concept.

External

This type of dress pack is recommended where there are less complexity in wrist movements. This normally occurs when there are not many different products running in the production cell. This package requires more individual adjustment to optimize towards robot program at set up.

Available options are 3325-11/12/13 and 3326-11/12/13 for material handling.

2.1.3 Limitations of robot movements

General

When using DressPack options on the upper arm the robot movements will be limited.

- In bending backwards positions there are limitations due to interference with manipulator.
- Might restrict working range, see [Working range axis 5 and axis 6 for LID variants on page 79](#).



Note

For more detail information please contact Serop Product support/SEROP/ABB.
E-mail address: serop.product_support@se.abb.com

Restrictions for all LID variants

Limitation for axis 5 and 6 depends on how the dress pack is assembled at the tool and how adjustment has been done.

Axis	Working range
Axis 5	120° to -120°
Axis 6	220° to -220°

2 DressPack

2.1.4 Impact on MH3 DressPack lifetime

2.1.4 Impact on MH3 DressPack lifetime

General

There are some robot movements/positions that shall be avoided in the robot production program. This will improve the lifetime significantly of external upper arm MH3 DressPack and wear parts e.g. protection hose, hose reinforcement and protective sleeves.

- The axis 5 movement is not allowed to press the DressPack against the robot upper arm.
- Combined rotation of the wrist axes must be limited so that the DressPack is not wrapped hard against the upper arm.

See the Product Manual for more detailed information and recommended set-up adjustments.

2.1.5 Information structure

General

The information for DressPack is structured in the following way.

The DressPack can be delivered in two versions developed for two different applications. Each type is described in a separate section.

Section	Option	Description
2.2	DressPack	DressPack includes general description DressPack with common information.

Connector kits

Section	Option	Description
2.3	Connector Kits	Includes general description of connector kits for DressPack.

2 DressPack

2.2.1 Introduction

2.2 DressPack

2.2.1 Introduction

Available DressPack configurations for Material Handling

The table below shows the different DressPack configurations available for Material Handling.

	Lower arm	Upper arm
Material Handling	Internal routing in lower arm	Option 3326/11/12/13, Axis 3 to axis 6 External routing
		Option 3326/30/31/32/33, Axis 3 to axis 6 (LID) Internal routing

Lower arm

Internal routing in lower arm

Option 3325-11/12/13, Base to axis 3

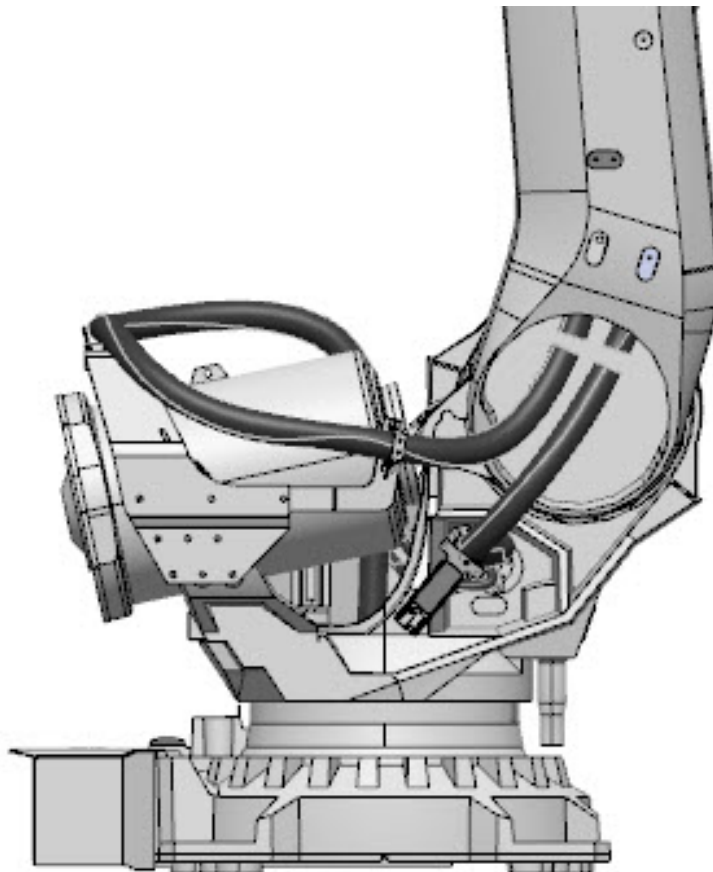

2.2.2 Built-in features for upper arm DressPack

External

Material handling (option 3326-11/12/13):

- Internal routing through the rear part of the upper arm.
- Protection hose can easily be replaced if damaged.
- One version for all IRB 6700 versions and all IRB 6700Inv versions.
- Adjustment for optimal hose/cable lengths.

Internal

Material handling (option 3326-31/32/33):

- Partly internal routing through the upper arm.
- Suitable for complex movements.
- High demands for flexibility and accessibility.
- Longer lifetime.
- Predictable movements.
- Easy exchange of DressPack.

2 DressPack

2.2.3 Interface descriptions for DressPack

2.2.3 Interface descriptions for DressPack

General

Below is an overview showing the different DressPack options connection points, and their locations. For detailed information see the circuit diagram, and *Product manual - DressPack/SpotPack IRB 6700*.

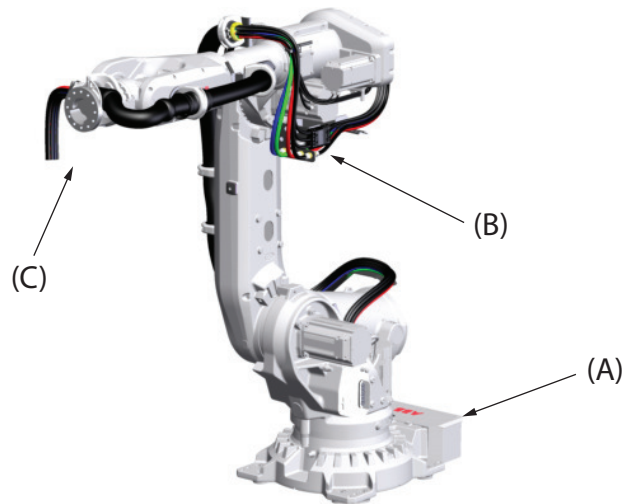

xx1300000224

Pos	Location	Description	Options
A	Base	CP/CS/CBUS	3325-11/12/13
B	Axis 3	CP/CS/CBUS	3325-11/12/13
C	Axis 6	CP/CS/CBUS	3326-11/12/13, 3326-31/32/33

Continues on next page

Base

Material handling (option 3325-11/12), see figure below:

- Included are: A, one D (Proc 1).

Material handling (option 3325-13), see figure below:

- Included are: A, E, F and one D.

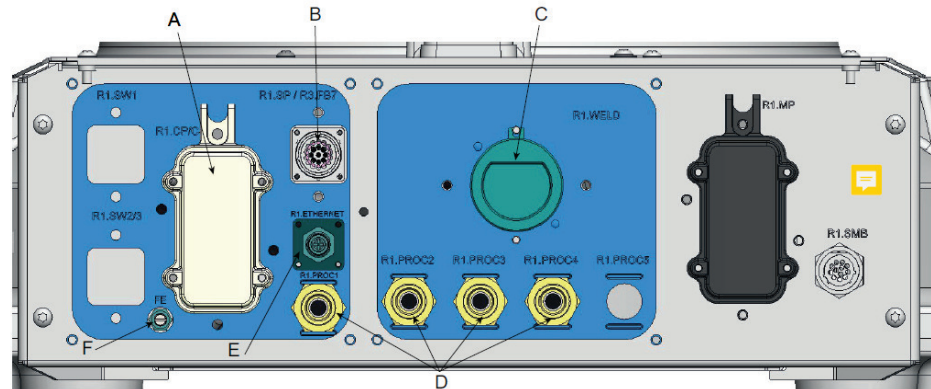

xx1900001501

For corresponding parts of the tool, see [Connection kits on page 109](#).

Pos	Description
A	R1.CP/CS
D	R1.PROC 1 (Material Handling) R1.PROC 2 - 4 (Not used)
E	R1.ETHERNET (M12 connector, when EtherNet communication is selected)
F	FE (Functional Earth, when EtherNet communication is selected)

Continues on next page

2 DressPack

2.2.3 Interface descriptions for DressPack

Continued

Axis 3

Material handling (option 3325-11), see figure below:

- Included are: A and one C (Proc 1).

Material handling (option 3325-12), see figure below:

- Included are: A, G and one C (Proc 1).

Material handling (option 3325-13), see figure below:

- Included are: A, B, H and one C (Proc 1).

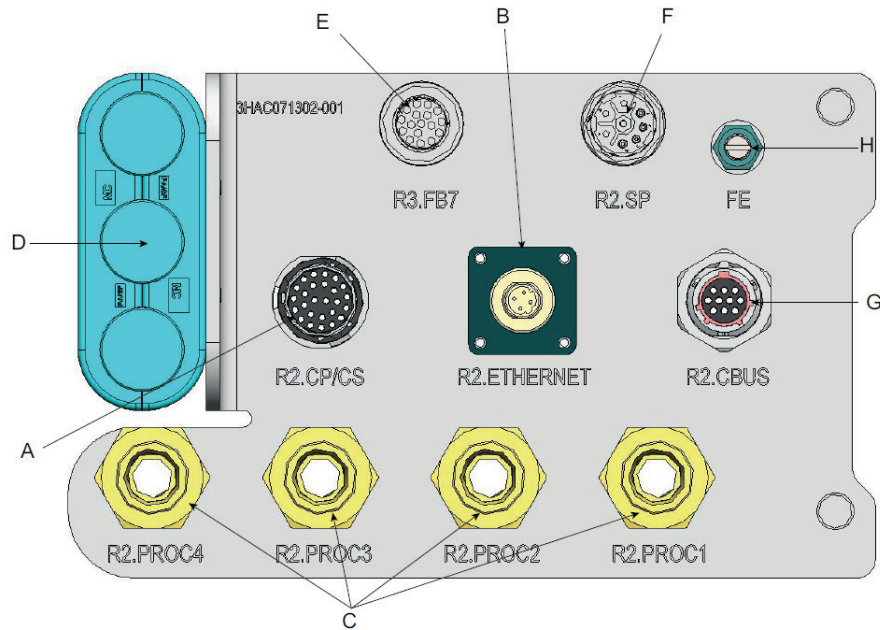

xx1900001511

For corresponding parts of the tool, see [Connection kits on page 109](#).

Pos	Description
A	R2.CP/CS
B	R2.ETHERNET (M12 connector, when EtherNet communication is selected)
G	R2.CBUS (UTOW connector when DeviceNet communication is selected)
H	FE (Functional Earth, when EtherNet communication is selected)

Continues on next page

Axis 6**External**

Material handling (option 3326-11/12/13), see figure below:

- Hose and cable free length, min. 1000 mm.
- Air hose ends with free end.

The cable ends with a connector, the main parts are described in the list below (for corresponding parts of the tool, see [Connection kits on page 109](#)):

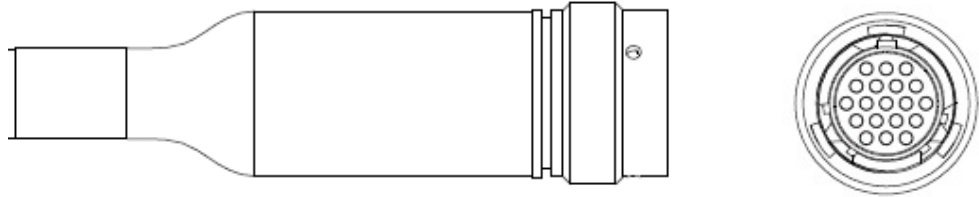

xx0900000728

Material handling connector

Material handling (option 3326-11/12/13), see figure below:

- Cable free length, min. 1000 mm.
- Signals are connected with a M12 connector.

The connectors are the same as for option 3326-31/32/33. The difference is the free length of the cables.

Continues on next page

2 DressPack

2.2.3 Interface descriptions for DressPack

Continued

Material Handling connector (LeanID)

Material Handling option 3326-31/32/33 (LeanID), see figure below:

- Hose and cable free length, min. 1160 mm.

The cable ends with connectors, for corresponding parts of the tool, see [Connection kits on page 109](#) and within the UTOW product offer.



xx2100002055

Pos	Description
A	R3.ETHERNET (M12 connector) EtherNet signals (when EtherNet communication is selected)
B	R3.CP/CS (UTOW connector 26p) Customer signals and power
C	R3.CBUS (UTOW connector 10p) BUS signals (when Profibus or DeviceNet communication is selected)
D	R3.PROC 1-2 (1/2", freeend) R3.PROC 2-4 (3/8", free end) Media hoses

- FE (M8 cable lug) When ethernet is selected option 3326-13/33

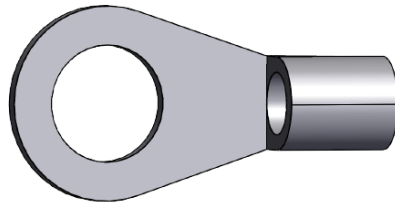

xx2000000109

2.2.4 Dimensions

Dimensions for robot with DressPack



Note

Dimensions for specific variant can be measured in 3D-Cad models.

Dimensions are shown in figures below.

Axis 3 to axis 6 (option 3326-11/12/13)

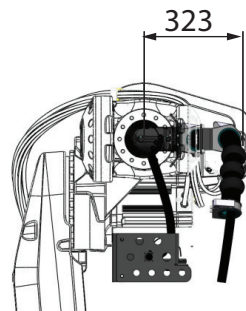

xx220000418

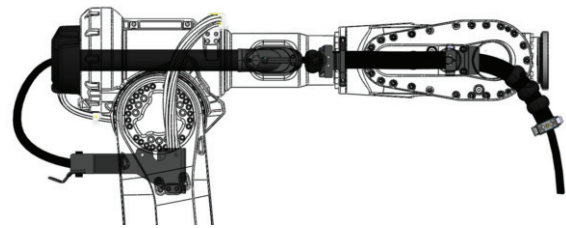

Continues on next page

2 DressPack

2.2.4 Dimensions

Continued

Option 3325-11/12/13 (Base to axis 3) + Option 3326-31/32/33 (Axis 3 to axis 6)

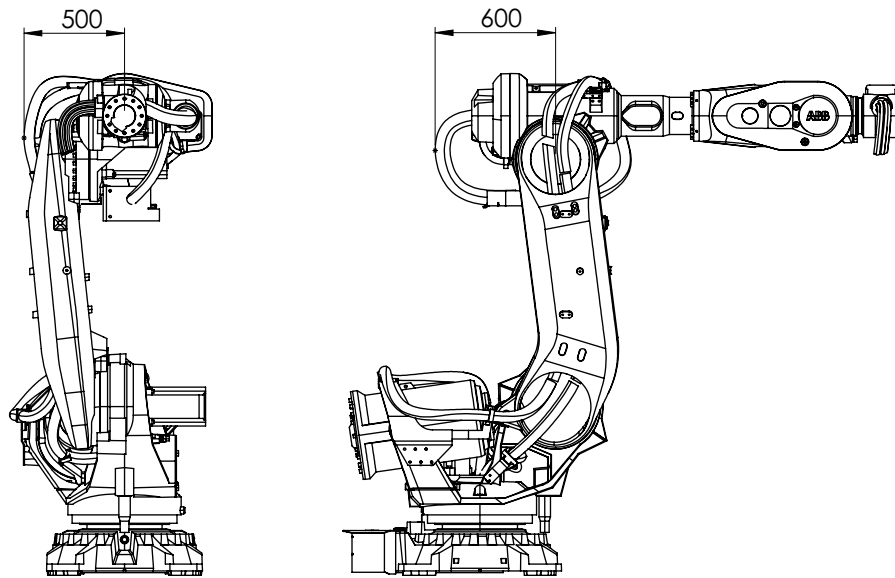

xx2000001776

2.3 Connection kits

General

Below is an example of how a connector kit and its parts can look like.



xx130000223

Continues on next page

2 DressPack

2.3.1 Base - Connector kits

2.3.1 Base - Connector kits

Available options

		DressPack options	Description
Option	Name	3325-11/12/13	
3330-2	CP/CS, Proc 1 base	X	



Note

Servo power connection kits not available.

Option 3330-2, CP/CS, Proc 1 on base

R1. CP/CS and Proc 1 on base for option 3325-11/12/13.

This option offers a kit with connectors. This must be assembled by the customer.

The kit contains:

- 1 Hose fittings (Swivel nut adapter, (1/2", M22x1,5 Brass, 24 degree seal))
- Connector with:

1 pcs Hood Foundry (Harting)	HAN EMC / M 40
1 pcs Hinged frame (Harting)	Shell size 16
2 pcs Multicontact, female (Harting)	Type HD (25 pin)
1 pcs Multicontact, female (Harting)	Type DD (12 pin)
1 pcs Multicontact, female (Harting)	Type EE (8 pin)
10 pcs Female crimp contacts	For 1.5 mm ²
10 pcs Female crimp contacts	For 0.5 mm ²
10 pcs Female crimp contacts	For 1.0 mm ²
10 pcs Female crimp contacts	For 2.5 mm ²
12 pcs Female crimp contacts	For 0.14– 0.37 mm ²
45 sockets	For 0.2– 0.56 mm ²
1 pcs M12 Connector, Male	
Assembly Accessories to complete connector	
Assembly instruction	

2.3.2 Axis 3 - Connector kits

Available options

		DressPack options	Description
Option	Name	3325-11/12/13	
3333-2	CP/CS bus, Proc 1 axis 3	X	UTOW

Option 3333-2, CP/CS/CBus, Proc 1 axis 3

CP/CS/CBus, Proc 1 axis 3 on tool side for option 3326-11/12/13 and 3326-31/32/33.

This kit offers a kit with connectors to be mounted at toolside of axis 3.

This must be assembled by the customer.

The kit contains:

- 1 Hose fitting (Parker Push lock (1/2", M22x1,5 Brass, 24 degree seal))
- Connector with:

CP/CS	
1 pcs UTOW Pin connector 26p, bayonet	UTOW61626PH, Shell size 16
26 pcs Pin	5 pcs RM18W3K and 21 pcs RM24W3K 0.13-0.25 mm ²
CBUS	
1 pcs UTOW Pin connector 10p, bayonet	UTOW61210PH Shell size 12
10 pcs Pin	RM24W3K 0.13-0.25 mm ²
Ethernet	
1 pcs Pin connector M12	Harting 2103 88
4 pcs Pin	Harting, 0.13-0.33 mm ²

2 DressPack

2.3.3 Axis 6 - Connector kits

2.3.3 Axis 6 - Connector kits

Available options

		DressPack options	DressPack options	Description
Option	Name	3326-11/12/13	3326-30/31/32/33	
3334-2	CP/CS bus axis 6	X	X	UTOW

Option 3334-2, CP/CS/CBus, Proc 1 axis 6

CP/CS/CBus/SP/SS, Proc 1 axis 6 on tool side for option 3326-11/12/13 and 3326-31/32/33.

This kit offers a kit with connectors to be mounted at toolside of axis 6.

This must be assembled by the customer.

The kit contains:

- 1 Hose fitting (Swivel nut adapter (1/2", M22x1,5 Brass, 24 degree seal))
- Connector with:

CP/CS	
1 pcs UTOW Pin connector 26p, bulkhead	UTOW71626PH05, Shell size 16
26 pcs Pin	5 pcs RM18W3K and 21 pcs RM24W3K 0.13-0.25 mm ²
CBUS	
1 pcs UTOW Pin connector 10p, bulkhead	UTOW71210PH05 Shell size 12
10 pcs Pin	RM24W3K, 0.13-0.25 mm ²
Ethernet	
1 pcs Socket connector M12	Harting 2103 88
4 pcs Socket	Harting, 0.13-0.33 mm ²

3 Specification of variants and options

3.1 Introduction to variants and options

General

The different variants and options for the IRB 6700 are described in the following sections. The same option numbers are used here as in the specification form.

The variants and options related to the robot controller are described in the product specification for the controller.

3 Specification of variants and options

3.2 Manipulator

3.2 Manipulator

Variants

Option	IRB Variants	Handling capacity (kg)	Reach (m)
3300-34	6700 - 300/2.70	300	2.70
3300-35	6700 - 270/2.70 LID	270	2.70
3300-36	6700 - 245/3.00	245	3.00
3300-37	6700 - 220/3.00 LID	220	3.00
3300-38	6700 - 235/2.65	235	2.65
3300-39	6700 - 220/2.65 LID	220	2.65
3300-40	6700 - 205/2.80	205	2.80
3300-41	6700 - 200/2.80 LID	200	2.80
3300-42	6700 - 200/2.60	200	2.60
3300-43	6700 - 175/2.60 LID	175	2.60
3300-44	6700 - 175/3.05	175	3.05
3300-45	6700 - 155/3.05 LID	155	3.05
3300-46	6700 - 155/2.85	155	2.85
3300-47	6700 - 140/2.85 LID	140	2.85
3300-48	6700 - 150/3.20	150	3.20
3300-49	6700 - 145/3.20 LID	145	3.20
3300-50	6700I - 300/2.60	300	2.60
3300-51	6700I-270/2.60 LID	270	2.60
3300-52	6700I - 245/2.90	245	2.90
3300-53	6700I - 210/2.90 LID	210	2.90

Manipulator color

Option	Description	Note
209-1	ABB Orange standard	
209-202	ABB Graphite White standard	Standard color
209-4 --192	Colors according to RAL-codes	



Note

Notice that delivery time for painted spare parts will increase for none standard colors.

Manipulator protection

Option	Description
3350-670	Base 67,IP67
3352-10	Foundry Plus2 67, IP67

Continues on next page

Requirements

The option *Foundry Plus2 67* [3352-10] requires option *Upper arm cover* [3316-1].



Note

It's strongly recommended, if Foundry Plus robots in other color than ABB Orange are required, that only colors in a yellow nuance are selected, if not the robot can look miss colored after a while in the foundry environment. The protection is still preserved in any color.



Note

Base 67 includes IP67, according to standard IEC 60529.

Warranty

For the selected period of time, ABB will provide spare parts and labour to repair or replace the non-conforming portion of the equipment without additional charges. During that period, it is required to have a yearly Preventative Maintenance according to ABB manuals to be performed by ABB. If due to customer restrains no data can be analyzed in the ABB Ability service *Condition Monitoring & Diagnostics* for robots with OmniCore controllers, and ABB has to travel to site, travel expenses are not covered. The Extended Warranty period always starts on the day of warranty expiration. Warranty Conditions apply as defined in the Terms & Conditions.



Note

This description above is not applicable for option *Stock warranty* [438-8]

Option	Type	Description
438-1	Standard warranty	Standard warranty is 12 months from <i>Customer Delivery Date</i> or latest 18 months after <i>Factory Shipment Date</i> , whichever occurs first. Warranty terms and conditions apply.
438-2	Standard warranty + 12 months	Standard warranty extended with 12 months from end date of the standard warranty. Warranty terms and conditions apply. Contact Customer Service in case of other requirements.
438-4	Standard warranty + 18 months	Standard warranty extended with 18 months from end date of the standard warranty. Warranty terms and conditions apply. Contact Customer Service in case of other requirements.
438-5	Standard warranty + 24 months	Standard warranty extended with 24 months from end date of the standard warranty. Warranty terms and conditions apply. Contact Customer Service in case of other requirements.
438-6	Standard warranty + 6 months	Standard warranty extended with 6 months from end date of the standard warranty. Warranty terms and conditions apply.

Continues on next page

3 Specification of variants and options

3.2 Manipulator

Continued

Option	Type	Description
438-7	Standard warranty + 30 months	Standard warranty extended with 30 months from end date of the standard warranty. Warranty terms and conditions apply.
438-8	Stock warranty	<p>Maximum 6 months postponed start of standard warranty, starting from factory shipment date. Note that no claims will be accepted for warranties that occurred before the end of stock warranty. Standard warranty commences automatically after 6 months from <i>Factory Shipment Date</i> or from activation date of standard warranty in WebConfig.</p> <p> Note</p> <p>Special conditions are applicable, see <i>Robotics Warranty Directives</i>.</p>

Foundry Plus Cable Guard

The manipulator cables are equipped with an additional protection of aluminized leather against e.g. aluminium spits and flashes and chips from machining.

Option	Type	Description
3315-1	Foundry Cable Guard	For extra protection of cables.

Upper arm cover

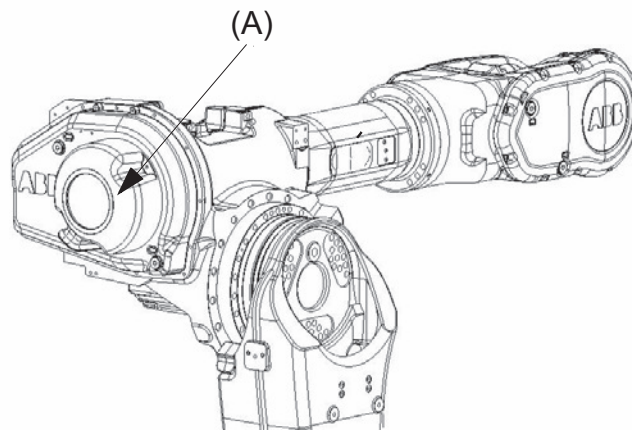

xx1400002039

Pos	Description
A	Option 3316-1

Requirements

The option *Upper arm cover* is required for foundryplus2 and dresspack axis 3-6 (3326-x).

Fork lift device

Option	Type	Description
3318-1	Fork lift on base	Can not be used for IRB 6700Inv.

Continues on next page

Option	Type	Description
3318-2	Fork lift on frame	

Working range limitation

To increase the safety of the robot, the working range of axis 1 can be restricted by extra mechanical stops.

Option	Description
3323-1	Axis 1 adjustable 15°

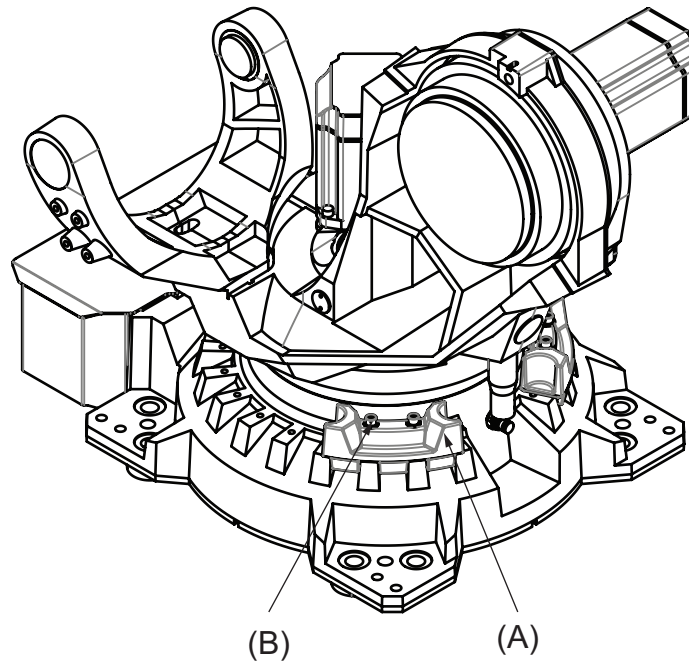

xx1400002035

Pos	Description
A	Two mechanical stops
B	Bolt tightening torque: 60 Nm

Extended working range

Option	Type	Description
3324-1	Axis 1 to $\pm 220^\circ$	<p>The option extends the working range on axis 1 from $\pm 170^\circ$ to $\pm 220^\circ$.</p> <p>When the option is used, the mechanical stop can after a risk-assessment be removed.</p> <p>Requires options SafeMove or EPS (Electronic Position Switches).</p>

This option is not available for IRB 6700Inv.

Continues on next page

3 Specification of variants and options

3.2 Manipulator

Continued



CAUTION

The option *Extended work range* enables an extension of the working range for axis 1, through a software configuration. With this option installed, the working range can exceed the range limited by the mechanical stop on axis 1. The working range shall be limited through the option *SafeMove*.

A risk analysis must be done to ensure that no risks remain when using option *Extended work range*, to limit the working range, and before removing the mechanical stops.

For information about the option *SafeMove*, see *Application manual - Functional safety and SafeMove*.

If the mechanical stop is removed, then the manipulator should have a marking for this, for example, a label. If the robot is delivered with the option *Extended work range*, then such a label is included on delivery.

3.3 Floor cables

Manipulator cable length

Option	Lengths
3200-2	7 m
3200-3	15 m
3200-4	22 m
3200-5	30 m

3 Specification of variants and options

3.4 Application

3.4 Application

PickMaster Ready

Option	Type	Description
3152-1	PickMaster Cell Ready	Includes conveyor tracking functionality. Digital I/O is needed for PickMaster functions.
3152-2	PickMaster Robot Ready	Includes conveyor tracking functionality. Digital I/O is needed for PickMaster functions.

PickMaster Vision

Option	Type	Description
3153-1	PickMaster Vision Ready	

Requirements

The option *PickMaster Vision Ready*[3153-1] requires option *PickMaster Robot Ready* [3152-2].

DressPack base-axis 3

Option	Description
3325-11	MH Parallel
3325-12	MH DeviceNet. Includes parallel signals
3325-13	MH EtherNet. Includes parallel signals, Supports ProfiNet, EtherNetIP

DressPack axis 3-6

Option	Description
3326-11	MH3 Parallel
3326-12	MH3 DeviceNet. Includes parallel signals
3326-13	MH3 EtherNet. Includes parallel signals, Supports ProfiNet, EtherNetIP
3326-31	MH LID Parallel
3326-32	MH LID DeviceNet. Includes parallel signals
3326-33	MH LID EtherNet. Includes parallel signals, Supports ProfiNet, EtherNetIP

Connector kit manipulator

The kit consists of connectors, pins and sockets. For technical description, see [Connection kits on page 109](#).

Option	Type	Description
3330-2	CP/CS bus, Proc 1 base	For the Customer Power/Customer Signal connector and one Process connector on the manipulator base. Sockets for bus communication are included.

Continues on next page

Option	Type	Description
3333-2	CP/CS bus, Proc 1 axis3	For the Customer Power/Customer Signal connector and one Process connector at axis 3. Pins for bus communication are included.
3334-2	CP/CS bus, Proc 1 axis6	Connector for customer power/customer signal/customer bus at axis 6 tool side.

Connection of Parallel/CAN DeviceNet communication

Following information specifies the cable length for Parallel/CAN DeviceNet/Ether-net + PROFIBUS floor cables for connections between cabinets and manipulator.

Option	Lengths
3201-2/3202-2/3204-2	7m
3202-3/3202-3/3204-3	15m
3202-4/3202-4/3204-4	22m
3202-5/3202-5/3204-5	30m

This page is intentionally left blank

Index

A

Absolute Accuracy, 27

Absolute Accuracy, calibration, 25

C

calibration

 Absolute Accuracy type, 24

 standard type, 24

calibration, Absolute Accuracy, 25

CalibWare, 24

category 0 stop, 93

category 1 stop, 93

compensation parameters, 27

E

equipment, on robot, 67

extended working range, 118

F

fine calibration, 26

fitting equipment to robot, 67

H

holes for equipment, 67

O

option

 Extended working range, 118

options, 113

P

product standards, 18

S

safety standards, 18

standards, 18

 ANSI, 18

 CAN, 18

standard warranty, 115

stock warranty, 115

stopping distances, 93

stopping times, 93

V

variants, 113

W

warranty, 115