

IRB 5510

Medium-sized paint robot



IRB 5510 FlexPainter is a highly flexible and accurate medium-sized paint robot for automotive small parts and general industrial painting. This robot provides a shorter cycle time, process optimization, and digital platform to ensure premium paint quality and uptime.

IRB 5510 offers the same advanced functions as IRB 5500 in a small form factor with a small foot print compared with other similar robots on the market. Highly versatile, IRB 5510 is aimed at small work piece painting, flaming treatment, and opener applications.

The increased acceleration provided by including IRB 5500 drivers and schematics allows us to equip IRB 5510 with advanced functions such as “StayOn”, as done very successfully with IRB 5500. This robot also provides a shorter cycle time, process optimization, and path control to ensure premium paint quality.

This functionality is crucial for industries where cycle time is essential to productivity, such as automotive small parts and General Industry (GI) customers. To address the needs of GI customers, IRB 5510 is designed for ease of use, streamlined manipulator maintenance, simplified software support, reduced operational costs, and increased spare parts availability.

IRB 5510 is equipped with ABB’s hollow wrist technology. This high-precision hollow wrist features a straight design that eliminates wear and tear on the paint- and air-supply hoses, increasing overall reliability.

Additionally, the wrist supports 140-degree rotation in any direction, making IRB 5510 one of the most versatile and easy-to-program paint robots in its class.

IRB 5510 also features ABB’s unique Integrated Process System (IPS) with closed-loop regulation capabilities and high-speed paint and airflow control. The IPS can increase process response times and reduce paint and solvent waste. Synchronizing the flow of paint with the motion of the robot arm improves transfer efficiency and minimizes overspray, thereby reducing paint wastage and increasing cost efficiency.

Why choose IRB 5510?

- This robot provides a shorter cycle time, process optimization, and digital platform to ensure premium paint quality.
- High-precision technologies including ABB’s hollow wrist, IPS, and bell technologies
- Inherent IRB 5500 family advantage
- Increased productivity with rapid installation and high system uptime
- Compact footprint
- State-of-art robot platform with digital infrastructure
- More scenarios for mounting

Specification

Number of axes	6
Payload on wrist	13 kg
Protection	IP66 (wrist IP54)
Ex approval	Explosion protected Ex i/Ex p/ Ex c for installation in hazardous area Zone 1 & Zone 21 ATEX, IECEx.
Mounting	Floor

Technical information

Mains voltage	200 - 600VAC, 3-phase, 50/60 Hz
Energy consumption	According to international standards

Dimensions

Robot footprint	581 x 717,5 mm
Robot controller	1450 x 725 x 710 mm

Weight

Robot unit	587 kg
Robot controller	180 kg

Ambient temperature

Robot unit	0 °C to +40 °C*
Robot controller	+48 °C maximum

Relative humidity	95 % maximum
-------------------	--------------

*Recommended max ambient temp <30°

RobView 5	Paint cell supervision and operation (included)
-----------	--

ShopFloor Editor	Off-line path- and process tuning using 3D graphics
------------------	--

RobotStudio® Paint	Full 3D simulation and programming of the paint cell
--------------------	---

Interface

Backup	USB connection and Ethernet
--------	-----------------------------

I/O boards	Analog, digital, encoder and process I/O boards available
------------	--

Fieldbus support	Interbus-S, ProfiBus, Profinet, CC Link, DeviceNet and Ethernet IP available
------------------	--

Network	Ethernet FTP/NFS
---------	------------------

Performance

Static repeatability (mm)	Wrist work envelope
0.15	±140 ²

IRB 5510 FlexPainter

Axis movement	Working range	Axis max speed
Axis 1	See work envelope drawings	100°/s
Axis 2	See work envelope drawings	100°/s
Axis 3	See work envelope drawings	100°/s
Axis 4 rotation	+/-720°	465°/s
Axis 5 bend	+/-720°	350°/s
Axis 6 turn	+/-460°	535°/s
Wrist working envelope +/-140°		

IRB 5510 FlexPainter, working range

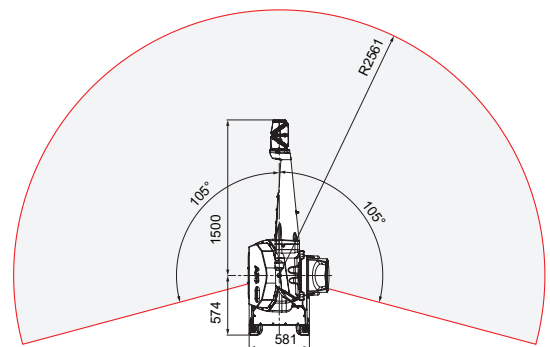
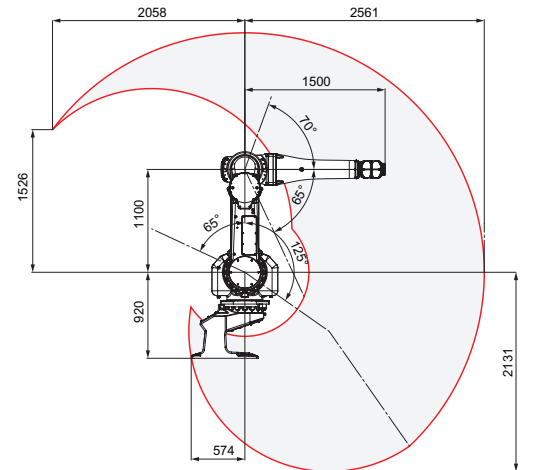

We reserve the right to make technical changes or modify the contents of this document without prior notice. With regard to purchase orders, the agreed particulars shall prevail. ABB does not accept any responsibility whatsoever for potential errors or possible lack of information in this document.

We reserve all rights in this document and in the subject matter and illustrations contained therein. Any reproduction, disclosure to third parties or utilization of its contents – in whole or in parts – is forbidden without prior written consent of ABB. Copyright © 2020 ABB. All rights reserved.