

IRB 5500-27

Compact paint robot with integrated 7-axis



IRB 5500-27 is a new variant of the innovative IRB 5500 robot family. Featuring integrated 7-axes that enable a wider working range and flexible installation positioning, IRB 5500-27 is capable of supporting both interior and exterior automotive painting, as well as other paint applications.

Design for universal backup in moving line and enhanced solution in stop & go line, IRB 5500-27 offers the increased flexibility and reach to accommodate diverse automotive body sizes, which can potentially reduce the number of robots required on a paint line. This increased flexibility combined with the ability to adjust the robot's installation position reduces cycle times.

Moreover, the integration of ABB's dynamic model for controlling all axes reduces overall energy consumption, increases accuracy, and ensures fully synchronized and balanced robot motion.

Paint savings

Our compact and light-weight paint application components enable us to put vital paint regulation equipment, like the pumps, as close as 15 cm from the wrist. This reduces paint and solvent waste during color change significantly.

We have integrated the process equipment in the IRB 5500 FlexPainter in addition to the fully integrated process control (hardware and software). The IRC5P is controlling both the paint process and the robot motion so you can enjoy substantial savings.

Powered by IPS

The "push-out" function integrated in the IPS system is one specific feature that enables a reduction of paint even further. The basic architecture of IPS is built on combining process control and motion control as one, this simplified the system set up and enables for real savings and process perfection.

Built for painting

Standard solutions accommodate color change valves for up to 32* colors with circulation, integrated in the process arm of the robot. Also, two pumps, driven by integrated servo motors, 64 pilot valves, atomizer control with dual shape air and closed loop regulation, closed loop regulation of bell speed and high voltage control – all fully integrated. Solutions for both solvent- and water-borne paint are available. Please note that more is available on special request.

Paint robot control system

IRC5P is a modern control system, specifically designed for the paint shop. With the IPS (Integrated Process System), the user friendly Ex certified Flex-Paint Pendant and RobView 5 it is a combination of standardized functions for the paint installation and to fit specific needs. This package includes standard applications for defining User screens, Program editing and Version control, and many more. RobView 5 can also be components in a larger Cell control HMI, like ABB FlexUI or other.

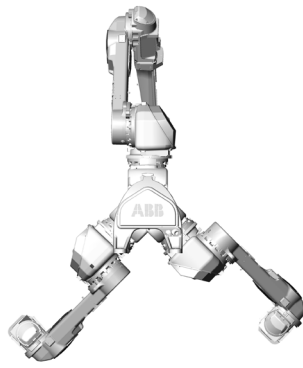

01

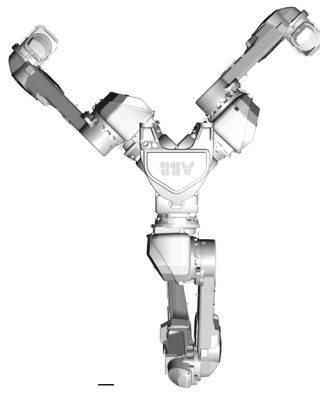

02

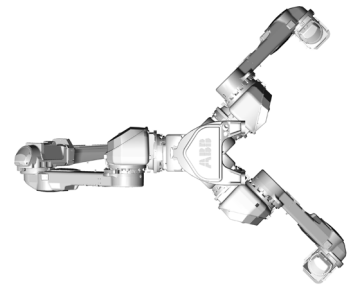

03

01 Working area
±135° with robot foot
mounted on floor/
top of pillar.

02 Working area
±135° with robot foot
mounted inverted.

03 Working area
±135° with robot foot
mounted on side of pillar.

Technical information

Electrical Connections

Mains voltage	200 - 600VAC, 3-phase, 50/60 Hz
Energy consumption	According to international standards

Physical

Dimensions

Robot footprint	750 x 650 mm
Robot controller	1450 x 725 x 710 mm

Weight

Robot unit	1180 kg
Robot controller	180 kg

Environment

Ambient temperature

Robot unit	0 °C to +40 °C*
Robot controller	+48 °C maximum

Relative humidity 95 % maximum

*Recommended max ambient temp <30°

PC Tools

RobView 5	Paint cell supervision and operation (included)
Painting PowerPac	Off-line and on-line path- and process tuning using 3D graphics
RobotStudio® Paint	Full 3D simulation and programming of the paint cell

Interface

Backup	USB connection and Ethernet
I/O boards	Analog, digital, relay, 120VAC, encoder and process I/O boards available
Fieldbus support	Interbus-S, ProfiBus, Profinet, CC Link, DeviceNet and Ethernet IP available
Network	Ethernet FTP/NFS

Performance (according to ISO 9283)

	Static repeatability (mm)	Wrist work envelope
IRB 5500-27	0.15	±140 ^g

Specification

Number of axes	7
Payload on wrist	13 kg
Protection	IP66 (wrist IP54)
Ex approval	Explosion protected Ex i/Ex p/ Ex c for installation in hazardous area Zone 1 & Zone 21 (Europe) and Division I, Class I & II.
Controller	IRC5P Paint
Mounting	Wall, floor, inverted

Movement

Axis movement	Working range	Axis max speed
Axis 1	See work envelope drawings	100°/s
Axis 2	See work envelope drawings	100°/s
Axis 3	See work envelope drawings	100°/s
Axis 4 rotation	+/-720°	465°/s
Axis 5 bend	+/-720°	350°/s
Axis 6 turn	+/-460°	535°/s
Axis 7	+/-135°	70°/s

Wrist working envelope +/-140°

Working range

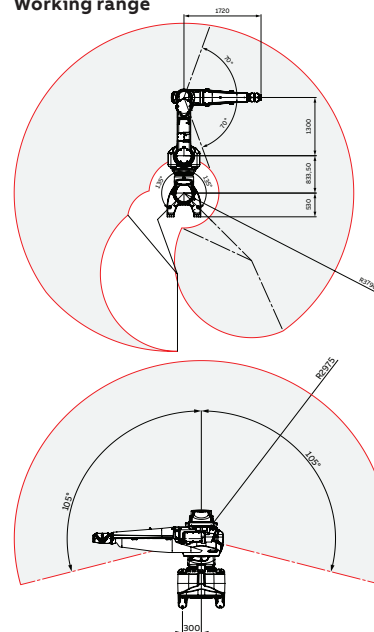

We reserve the right to make technical changes or modify the contents of this document without prior notice. With regard to purchase orders, the agreed particulars shall prevail. ABB does not accept any responsibility whatsoever for potential errors or possible lack of information in this document.

We reserve all rights in this document and in the subject matter and illustrations contained therein. Any reproduction, disclosure to third parties or utilization of its contents – in whole or in parts – is forbidden without prior written consent of ABB. Copyright © 2019 ABB. All rights reserved