

## IRB 1200

A compact, flexible, fast and functional small industrial robot



Have you ever wanted to make your machines 15% smaller and 10% faster? ABB's IRB 1200 allows you to do exactly that. Specifically, it addresses the needs of material handling and machine tending applications for flexibility, ease of use, compactness and short cycle times while still maintaining large working envelopes.

As a family of robots, the IRB 1200 comes in two variants which can handle a wide range of applications. Both IRB 1200 variants can be mounted at any angle and come with IP 40 protection as standard. Both variants are available with Food Grade Lubrication, SafeMove, Foundry Plus 2 and Clean Room option. The 700 mm reach variant can carry a payload of up to 7 kg, while the longer reach 900 mm variant can carry up to 5 kg of payload.

### Food Grade Lubrication and Clean Room option

This Food Grade Lubrication (NSF H1) option includes Clean Room ISO class 3 and IP67 protection rating which ensure uncompromising safety and hygiene for food and beverage applications. The Clean Room ISO class 3 design eliminates the potential for contamination of the food handling area. This option provides smooth surfaces and makes it easy to keep clean and maintain in environments such as CNC machine tending and material handling in the food industry. This results in features that allow for 15% smaller cells with 10% shorter cycle times.

### SafeMove

The IRB 1200 SafeMove becomes the smallest ABB robot to feature the advanced safety-certified monitoring and control software solution which allows robots and operators to work more closely together by restricting robot motion to precisely what is needed for a specific application.

### Compact

The IRB 1200 has no offset in axis two, which results in a longer stroke than other small robots and it, meaning it can be placed very close to the work piece and still be functional. This allows for a much more compact installation when the robot is mounted on the ceiling inside a small cell, such as in electronics machining or polishing applications. The robots' large useable working area contained in a small package leads to shorter cycles and more compact machines.

### Foundry Plus 2

The IRB 1200 is also available with Foundry Plus 2, ABB's optional protection system which allows it to withstand harsh environments for example heavy duty metal casting and automotive applications.

### Features and benefits

- 15% smaller cells that have 10% shorter cycle times
- Available with Food Grade Lubrication
- Optionally with SafeMove functionality
- Available with Foundry Plus 2 protection for harsh environments
- IP40 protection as standard; Clean Room, IP67 and Foundry Plus 2 protection are also available options
- 4 air ducts, 10 customer signals and Ethernet routed internally from wrist flange to foot
- Mountable at any angle
- Large useable working area in a compact footprint

## Specification

Robot version	Reach (m)	Payload (kg)	Armload (kg)
IRB 1200-7/0.7	0.7	7	0.3
IRB 1200-5/0.9	0.9	5	0.3
Number of axes	6		
Protection	Standard IP40 Option IP67 and Foundry Plus 2		
Cleanroom	Option ISO class3		
Food Grade Lubricant	Option, only available with IRC5		
Mounting	Any angle		
Controller	OmniCore C30, C90XT, IRC5 Compact /IRC5 Single Cabinet		
Integrated signal and power supply	10 signals on wrist		
Integrated air supply	4 air on wrist (5 Bar)		
Integrated ethernet	One 100/10 Base-TX ethernet port		

## Performance (according to ISO 9283)

	IRB 1200-7/0.7	IRB 1200-5/0.9
1 kg picking cycle		
25 x 300 x 25 mm	0.41s <sup>1</sup>	0.42s <sup>1</sup>
Max. TCP Acceleration	35 m/s*s	36 m/s*s
Acceleration time 0-1 m/s	0.06 s	0.06 s
Position repeatability	0.02 mm	0.025 mm

<sup>1</sup> based on OmniCore C30

## Technical information

### Electrical Connections

Supply voltage	200-600 V, 50-60 Hz
Rated power transformer rating	4.5 kVA
Power consumption	0.39 kW

### Physical

Robot base	210 x 210 mm
Robot height	
IRB 1200-7/0.7	869 mm
IRB 1200-5/0.9	967 mm
Robot weight	
IRB 1200-7/0.7	52 kg
IRB 1200-5/0.9	54 kg

### Environment

Ambient temperature for robot manipulator	
During operation	+ 5°C (41°F) to + 45°C (113°F)
With food grade lubrication during operation	+ 5°C (41°F) to + 35°C (95°F)
Complete robot during transportation and storage	- 25°C (-13°F) to + 55°C (131°F)
During short periods (max. 24 hours)	up to + 70°C (158°F)
Relative humidity	Max. 95%
Noise level	< 70 dB

Data and dimensions may be changed without notice.

We reserve the right to make technical changes or modify the contents of this document without prior notice. With regard to purchase orders, the agreed particulars shall prevail. ABB does not accept any responsibility whatsoever for potential errors or possible lack of information in this document.

## Movement

Axis movement	Working range	Axis max. speed
Axis 1 rotation	+170° to -170°	288°/s
Axis 2 arm	+135° to -100° <sup>2</sup>	240°/s
Axis 3 arm	+70° to -200°	300°/s
Axis 4 wrist	+270° to -270°	400°/s
Axis 5 bend	+130° to -130°	405°/s
Axis 6 turn	Default: +400° to -400° Max. rev: ±242	600°/s

<sup>2</sup> Axis 2 for IRB 1200-5/0.9 is +130° to -100°

### Working range, IRB 1200 7/0.7

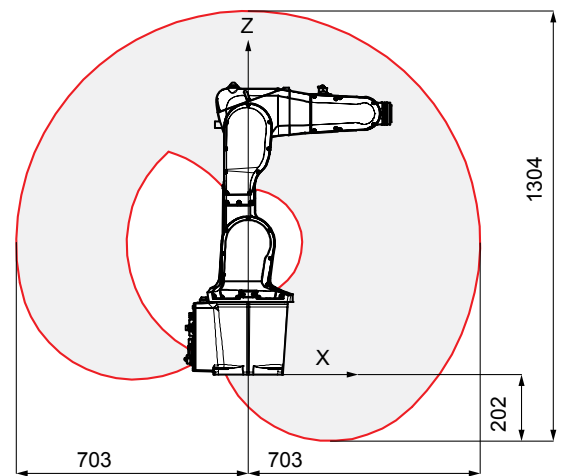

### Working range, IRB 1200 5/0.9

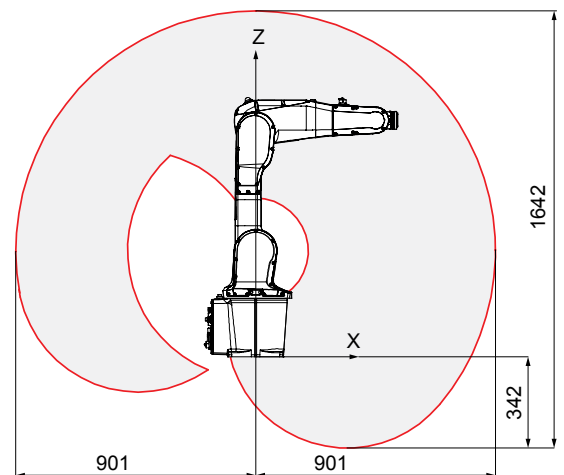

We reserve all rights in this document and in the subject matter and illustrations contained therein. Any reproduction, disclosure to third parties or utilization of its contents – in whole or in parts – is forbidden without prior written consent of ABB. Copyright© ABB  
All rights reserved